

- Contact
- Dual Element
- Angle Beam
- Shear Wave
- Delay Line
- Protected Face
- Immersion
- TOFD
- High Frequency
- Atlas European Standard

Olympus is a global technology leader, crafting innovative optical and digital solutions in medical technologies; life sciences; industrial solutions; and cameras and audio products. Throughout our 100-year history, Olympus has focused on being true to society and making people's lives healthier, safer, and more fulfilling.

Our Scientific Solutions Division is committed to the safety and betterment of society through the pioneering, development, and manufacture of world-leading test and measurement solutions. These solutions are used in industrial and research applications ranging from aerospace, power generation, petrochemical, civil infrastructure, automotive, and consumer products.

Olympus Ultrasonic Transducers

Our conventional ultrasonic transducers are available in more than 5000 variations in frequency, element diameter, and connector styles. With more than forty years of transducer experience, Olympus has developed a wide range of custom transducers for special applications in flaw detection, weld inspection, thickness gaging, and materials analysis.



Table of Contents

- The Company 2
- Ultrasonic Transducers 2
- Transducer Selection 4
- Part Number Configurations 6
- Test and Documentation 7
- Contact Transducers 8
 - Standard Contact 9
 - Magnetic Hold Down Contact 9
- Dual Element Transducers 10
 - Flush Case Duals 10
 - Flush Case Dual Cables 10
 - Composite Element Flush Case Duals 10
 - Fingertip Duals 11
 - Miniature Tip Dual 11
 - Miniature Tip Dual Cables 11
 - Extended Range Duals 11
- Angle Beam Transducers and Wedges 12
 - Miniature Screw-In Transducers 12
 - Miniature Screw-In Wedges for 1–5 MHz 13
 - Miniature Screw-In Wedges for 10 MHz Transducers 13
 - Standard Angle Beam Transducers and Wedges 14
 - Integral Angle Beam Transducers 15
 - Shear Wave Wedges for Aluminum 15
 - Contoured Wedges 15
 - AWS Wedges and Transducers 16
 - CDS Wedges 16
- Normal Incidence Shear Wave Transducers 17
 - Direct Contact Series 17
 - Delay Line Series 17
 - Shear Wave Couplant 17
- Delay Line Transducers 18
 - Replaceable Delay Line Options 18
 - Sonopen® Replaceable Delay Line Transducer 19
 - Permanent Delay Line Transducers with Handle Assembly 19
- Protected Face Transducers 20
 - Standard Protected Face 20
 - High-Temperature Delay Line Options 21
 - Protective Membrane Option 21
 - Protective Wear Cap Option 21

- Immersion Transducers 22
 - Standard Case 22
 - Large-Diameter Case 23
 - Slim-Line Case 23
 - Pencil Case 24
 - Side Looking Immersion Transducers 24
 - Extra Miniature (XMS) Transducer 24
 - Accuscan® Paintbrush 25
 - Reflector Mirrors 25
 - Immersion Search Tubes 25
 - Bubblers 26
 - RBS-1 Immersion Tank 26
 - Handheld Bubbler Transducer Assembly 26
 - Spot Weld Transducers 27
- High-Frequency Transducers 28
 - High-Frequency Contact 28
 - High-Frequency Standard Immersion Case 29
 - High-Frequency SU/RM Immersion Case 29
- Dual Element Transducers for Thickness Gages 30
 - Gage Dual Transducers 30
 - Gage Dual Cables 31
- Other Thickness Gage Transducers 31
 - Electromagnetic Acoustic Transducer (EMAT) 31
 - 500 kHz Broadband/Highly Damped Transducer 31
- Atlas® European Standard Transducers 32
 - Dual Element Transducers 32
 - Contact Transducers 32
 - Integral Angle Beam Transducers 33
 - Integral Angle Beam with Composite Elements 34
 - Protected Face Transducers 34
 - Protective Membrane Accessories 34
- TOFD Transducers 35
- Test Blocks 36
 - Calibration Blocks 36
 - Reference Blocks 37
 - Thickness Calibration Blocks 37
- Cables 38
 - Standard 38
 - Heavy Duty (HD) 38
 - Waterproof (W) 38
 - Armored Stainless Steel (SSA) 38
 - Double Shielded (DS) 38
 - Cables with Handle 38
 - Dual 39
 - Heavy Duty, Armored PVC (HDAP) 39
 - Heavy Duty, Armored Super Flexible Silicone (HDAS) 39
 - Atlas (Metric Lengths) 39
- Couplants and Adaptors 40



Transducer Selection

The transducer is one of the most critical components of any ultrasonic system. A great deal of attention should be paid to selecting the proper transducer for the application.

The system's performance as a whole is important. Variations in instrument characteristics and settings as well as material properties and coupling conditions play a major role in system performance.

We have developed three different series of transducers to respond to the need for variety. Each series has its own unique characteristics.

The transducer configuration also has an impact on system performance. Consideration should be given to the use of focused transducers, transducers with wear surfaces that are appropriate for the test material, and the choice of the appropriate frequency and element diameter.

The summaries below provide a general description of the performance characteristics of each transducer series. While these guidelines are useful, each application is unique and performance will be dependent on electronics, cabling, and transducer configuration, frequency, and element diameter.

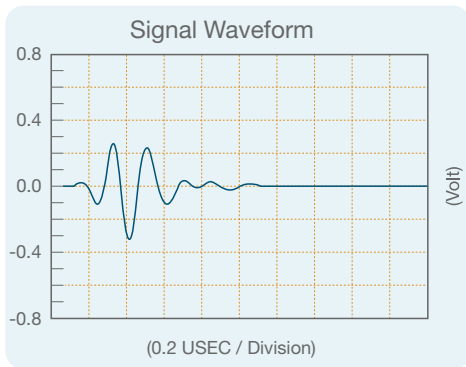

Accuscan® "S" Series

The Accuscan S series provides excellent sensitivity in those situations where axial resolution is not of primary importance. Typically, this series will have a longer waveform duration and a relatively narrow frequency bandwidth.

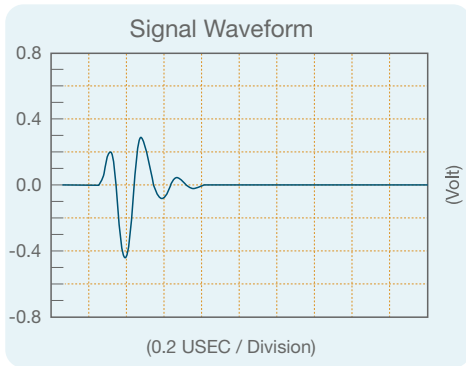
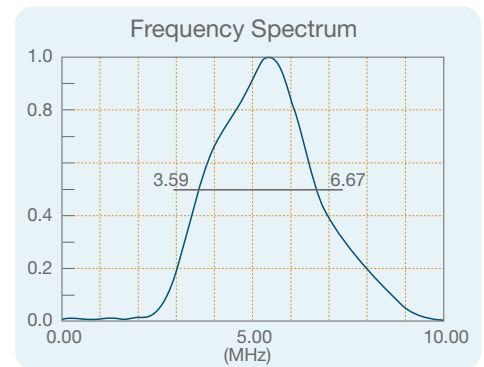

Centrascan® Series

The piezocomposite element Centrascan series transducers provide excellent sensitivity with a high signal-to-noise ratio in difficult-to-penetrate materials. They have exceptional acoustic matching to plastics and other low-impedance materials.

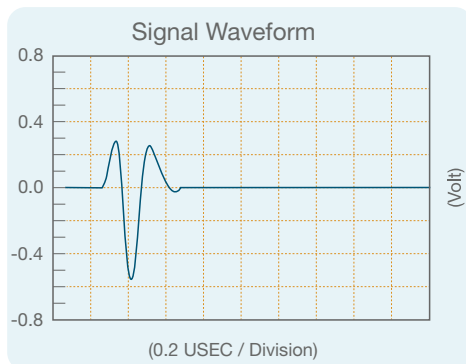
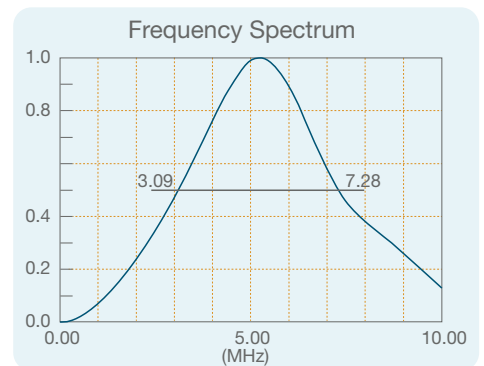

Videoscan® Series

Videoscan transducers are untuned and provide heavily damped broadband performance. They are the best choice in applications where good axial or distance resolution is necessary or in tests that require improved signal-to-noise in attenuating or scattering materials.

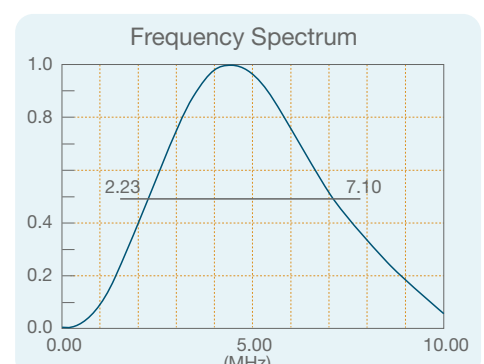

Note: For more information on bandwidth and sensitivity versus resolution, please refer to the "Ultrasonic Transducers Technical Notes" on our website.
Note: For sample test forms of transducers that you are interested in purchasing or if you have questions, please contact us via phone or email.



Contact Transducers: A contact transducer is a single element transducer, usually generating a longitudinal wave, that is intended for direct contact with a test piece. All contact transducers are equipped with a wear face that offers superior wear resistance and probe life as well as providing an excellent acoustic impedance match to most metals. Please see "Contact Transducers" on page 8 for more details on longitudinal contact probes and "Normal Incidence Shear Wave Transducers" on page 17 for information on normal incidence shear wave transducers.



Dual Element Transducers: A dual element transducer consists of two longitudinal wave crystal elements (one transmitter and one receiver) housed in the same case and isolated from one another by an acoustic barrier. The elements are angled slightly toward each other to bounce a signal off the back wall of a part in a V-shaped pattern. Dual element transducers typically offer more consistent readings on heavily corroded parts and can also be used in high-temperature environments. Please see "Dual Element Transducers" on page 10 for more information on dual element transducers for flaw detection or "Dual Element Transducers for Thickness Gages" on page 30 for dual element probes for use with Olympus corrosion gages.

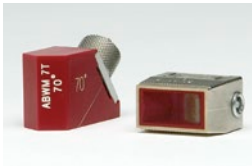

Angle Beam Transducers: Angle beam transducers are single element transducers used with a wedge to introduce longitudinal or shear wave sound into a part at a selected angle. Angle beam transducers allow inspections in areas of a part that cannot be accessed by the ultrasonic path of a normal incidence contact transducer. A common use for angle beam transducers is in weld inspection, where a weld crown blocks access to the weld zone of interest for a standard contact transducer and where typical flaw alignment produces stronger reflections from an angled beam. Please read "Angle Beam Transducers and Wedges" on page 12 for additional information on angle beam transducers and wedges. For a detailed explanation of how wedges are designed using Snell's Law, please refer to our "Ultrasonic Transducers Technical Notes."



Delay Line Transducers: Delay line transducers are single element broadband contact transducers designed specifically to incorporate a short piece of plastic or epoxy material in front of the transducer element. Delay lines offer improved resolution of flaws very near to a part's surface and enable a thinner range and more accurate thickness measurements of materials. Delay lines can be contoured to match the surface geometry of a part and can also be used in high-temperature applications. For more information on delay line transducers and delay line options, please see "Delay Line Transducers" on page 18.



Protected Face Transducers: Protected face transducers are single element longitudinal wave transducers with threaded case sleeves for a wear cap or membrane to be attached. This makes them extremely versatile and able to cover a very wide range of applications. Protected face transducers can also be used as a direct contact transducer on lower impedance materials, such as rubber or plastic, for an improved acoustic impedance match. Please see "Protected Face Transducers" on page 20 for more information on protected face transducers and the options available for use with them.



Immersion Transducers: Immersion transducers are single element longitudinal wave transducers whose wear face is impedance matched to water. Immersion transducers have sealed cases allowing them to be completely submerged under water when used with a waterproof cable. By using water as both a couplant and delay line, immersion transducers are ideal for use in scanning applications where consistent coupling to the part is essential. As an additional option, immersion transducers can also be focused to increase the sound intensity in a specific area and decrease the spot size of the sound beam. For additional information on immersion transducers and an in-depth explanation of focusing, please see the immersion probe sections on page 22 and our technical notes.



High-Frequency Transducers: High-frequency transducers are either fused silica delay line or focused immersion transducers and are available in frequencies from 20 MHz to 225 MHz. High-frequency fused silica delay line transducers are capable of making thickness measurements on materials as thin as 0.0004 in. (0.010 mm) (dependent on material, transducer, surface condition, temperature, and setup), while high-frequency focused immersion transducers are ideal for high-resolution imaging and flaw detection applications on thin, low-attenuation materials, such as silicon microchips. For more information on all high-frequency transducers, please see "High-Frequency Transducers" on page 28.

Part Number Configurations

Connector Style

RB



Right Angle BNC

SB



Straight BNC

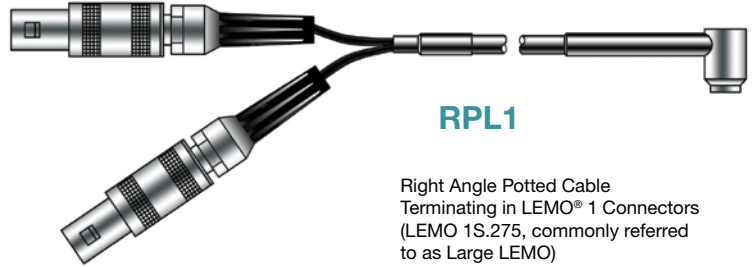

RPL1

Right Angle Potted Cable
Terminating in LEMO® 1 Connectors
(LEMO 1S.275, commonly referred to as Large LEMO)

RM

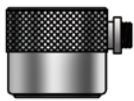

Right Angle
Microdot

SM



Straight
Microdot

SU



Straight UHF

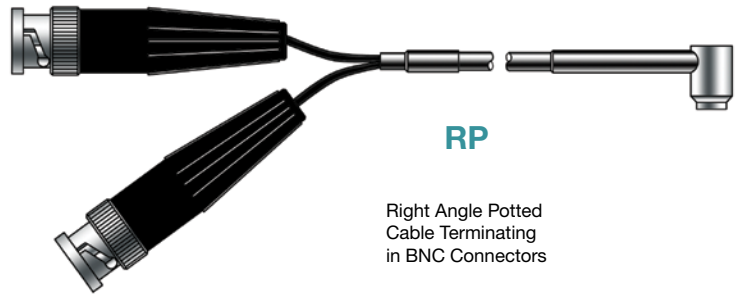

RP

Right Angle Potted
Cable Terminating
in BNC Connectors

Contoured Delays

CC-R



Concave Radius

CX-R



Convex Radius

Part number example
DLH-1-CC-R1.25IN

Contoured Wedges

AID



Axial Inside
Diameter

AOD



Axial Outside
Diameter

CID



Circumferential
Inside Diameter

COD



Circumferential
Outside Diameter

Part number example
ABWM-4T-45-COD1.25IN

Focal Types

(Immersion Transducers)

F

Spherical Focus

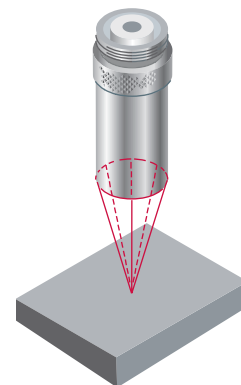

CF

Cylindrical Focus

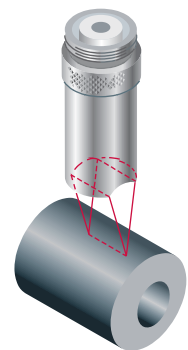

Focal Designations

PTF	Point Target Focus
FPF	Flat Plate Focus
OLF	Optical Limit Focus

Part number example
V309-SU-F1.00IN-PTF

Test and Documentation

Olympus is a leader in the development of transducer characterization techniques and has participated in the development of the ASTM E1065 *Standard Guide for Evaluating Characteristics of Ultrasonic Search Units*. We have performed characterizations according to AWS, AITM, and EN12668-2. As part of the documentation process, an extensive database containing records of the waveform and spectrum of each transducer is maintained and can be accessed for comparative or statistical studies of transducer characteristics. Our test lab offers a variety of documentation services including the below tests. Please consult us concerning special testing requirements.

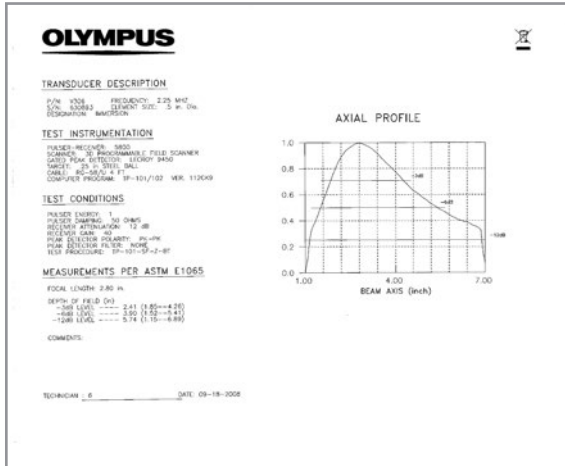

Beam Profiles (TP101)

The axial beam profile gives the amplitude of the sound field as a function of distance from the transducer face and provides information on the depth of field, near field, or focal length. It cannot be applied to transducers with specified or natural focal lengths greater than 7.50 in. (190 mm) or frequencies greater than 25 MHz.

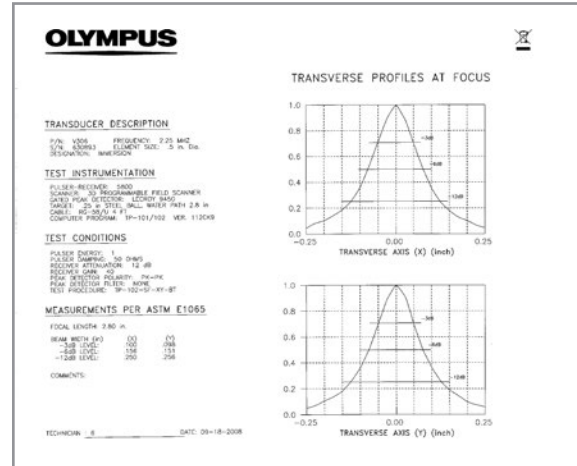

Beam Profiles (TP102)

The transverse beam profile shows the amplitude of the sound field as the transducer is moved across a ball target in a plane parallel to the transducer face. It's typically performed at the near field or focal length distance and in both X and Y axes. It cannot be applied to transducers with specified or natural focal lengths greater than 15 in. (381 mm) or frequencies greater than 25 MHz.

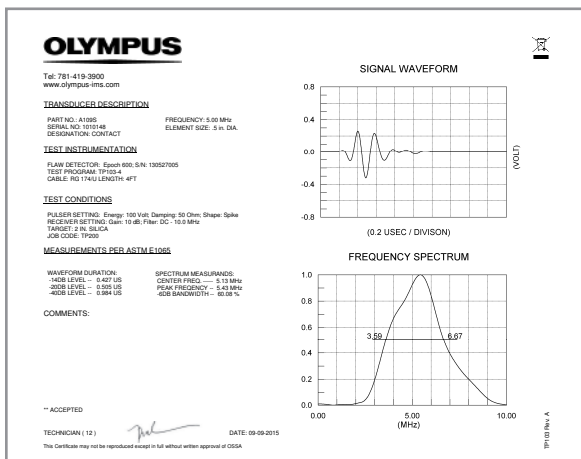

Standard Test Forms (TP103)

Recording of the actual RF waveform and frequency spectrum for each transducer. Each test form has measurements of the peak and center frequencies, upper and lower -6 dB frequencies, bandwidth, and waveform duration according to ASTM-E 1065. The standard test form ships with all Accuscan®, Centrascan®, and Videoscan® transducers.*

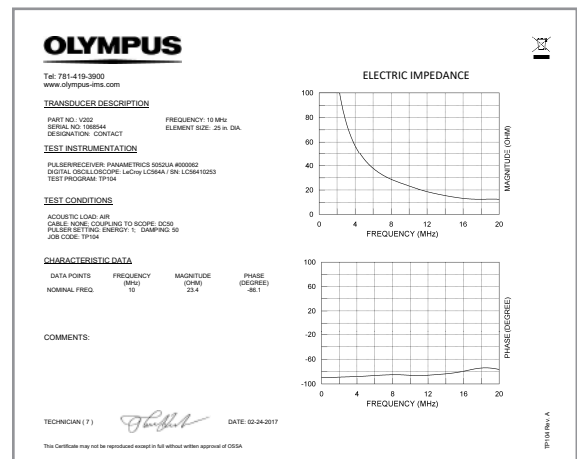

Electrical Impedance Plots (TP104)

The electrical impedance plot provides information on the electrical characteristics of a transducer and how it loads a pulser. The TP104 displays the impedance magnitude versus frequency and the phase angle versus frequency. It can be generated from most types of transducers.

*Select transducers receive other certificates instead of TP103s; integral angle beam probes are issued TP105 forms denoting refracted angles, and corrosion duals receive TP106 forms in accordance with EN15317.

Contact Transducers

A contact transducer is a single element longitudinal wave transducer intended for use in direct contact with a test piece.

Advantages

- Wear plate increases durability, fracture resistance, and wear resistance
- All styles are designed for use in rugged industrial environments
- Close acoustic impedance matching to most metals
- Can be used to test a wide variety of materials

Applications

- Straight beam flaw detection and thickness gaging
- Detection and sizing of delaminations
- Material characterization and sound velocity measurements
- Inspection of plates, billets, bars, forgings, castings, extrusions, and a wide variety of other metallic and nonmetallic components
- For continuous use on materials up to 122 °F (50 °C)

Fingertip Contact

- Units larger than 0.25 in. (6 mm) are knurled for easier grip
- 303 stainless steel case
- Low profile for difficult-to-access surfaces
- Standard configuration is Right Angle and uses a Microdot™ connector



Transducer Dimensions (in inches)		
Nominal Element Size	(A)	(B)
1.00	1.25	0.63
0.75	1.00	0.63
0.50	0.70	0.63
0.375	0.53	0.50
0.25	0.35	0.50
0.125	0.25	0.38

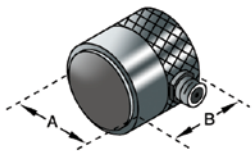

Freq	Nominal Element Size		Transducer Part Numbers		
	in.	mm	ACCUSCAN-S	CENTRASCAN	VIDEOSCAN
0.5	1.00	25	A101S-RM	—	V101-RM
	1.00	25	A102S-RM	—	V102-RM
1.0	0.75	19	A114S-RM	—	V114-RM
	0.50	13	A103S-RM	—	V103-RM
2.25	1.00	25	A104S-RM	—	V104-RM
	0.75	19	A105S-RM	—	V105-RM
	0.50	13	A106S-RM	C106-RM	V106-RM
	0.375	10	A125S-RM	C125-RM	V125-RM
3.5	0.25	6	A133S-RM	C133-RM	V133-RM
	1.00	25	A180S-RM	—	—
	0.75	19	A181S-RM	—	V181-RM
	0.5	13	A182S-RM	—	V182-RM
	0.375	10	A183S-RM	—	V183-RM
	0.25	6	A184S-RM	—	—
5.0	1.00	25	A107S-RM	—	V107-RM
	0.75	19	A108S-RM	—	V108-RM
	0.50	13	A109S-RM	C109-RM	V109-RM
	0.375	10	A126S-RM	C126-RM	V126-RM
	0.25	6	A110S-RM	C110-RM	V110-RM
	0.125	3	—	—	V1091
7.5	0.50	13	A120S-RM	—	—
	0.375	10	A122S-RM	—	V122-RM
	0.25	6	A121S-RM	—	V121-RM
10	0.50	13	A111S-RM	—	V111-RM
	0.375	10	A127S-RM	—	V127-RM
	0.25	6	A112S-RM	—	V112-RM
	0.125	3	—	—	V129-RM
15	0.25	6	A113S-RM	—	V113-RM
20	0.125	3	—	—	V116-RM

Standard Contact

- Comfort fit sleeves designed to be easily held and to provide a steady grip while wearing gloves
- 303 stainless steel case
- Large element diameters for increased sound energy and greater coverage
- Standard connector style is Right Angle BNC (RB); may be available in a Straight BNC (SB)

Frequency	Nominal Element Size		Transducer Part Numbers		
	MHz	in.	mm	ACCUSCAN-S	
0.1	1.50	38	—	—	V1011
0.25	1.50	38	—	—	V1012
0.5	1.5	38	A189S-RB	A189S-RB	V189-RB
	1.00	25	A101S-RB	A101S-RB	V101-RB
1.0	1.50	38	A192S-RB	A192S-RB	V192-RB
	1.00	25	A102S-RB	A102S-RB	V102-RB
	0.75	19	A114S-RB	A114S-RB	V114-RB
	0.50	13	A103S-RB	A103S-RB	V103-RB
2.25	1.5	38	A195S-RB	A195S-RB	V195-RB
	1.00	25	A104S-RB	A104S-RB	V104-RB
	0.75	19	A105S-RB	A105S-RB	V105-RB
	0.50	13	A106S-RB	A106S-RB	V106-RB
	0.25 × 1	6 × 25	A188S-RB*	—	—
3.5	1.00	25	A180S-RB	A180S-RB	V180-RB
	0.75	19	A181S-RB	A181S-RB	V181-RB
	0.50	13	A182S-RB	A182S-RB	V182-RB
5.0	1.00	25	A107S-RB	A107S-RB	V107-RB
	0.75	19	A108S-RB	A108S-RB	V108-RB
	0.50	13	A109S-RB	A109S-RB	V109-RB
7.5	0.50	13	A120S-RB	A120S-RB	V120-RB
10	0.50	13	A111S-RB	A111S-RB	V111-RB

*Per ASTM Standard A-418

1.125 in. element diameter 0.5, 1.0, and 2.25 MHz probes may be available upon request.

Magnetic Hold Down Contact

- Magnetic ring around transducer case for stationary positioning on ferrous materials
- Broadband performance similar to Videoscan® series

Frequency	Nominal Element Size		Part Number
	MHz	in.	
5.0	0.5	13	M1042
	0.25	6	M1057
10	0.25	6	M1054
15	0.25	6	M1055

All above magnetic hold down transducers have straight Microdot connectors.

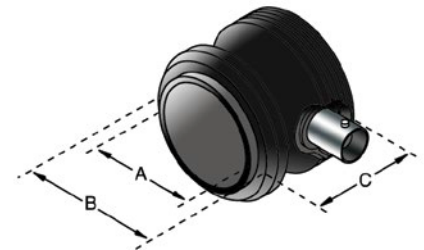

Transducer Dimensions (in inches)			
Nominal Element Size	(A)	(B)	(C)
1.50	1.75	2.23	1.25
1.50*	1.75	2.50	2.50
1.125	1.38	1.79	1.25
1.00	1.25	1.60	1.25
0.25 × 1.00	1.25	1.60	1.25
0.75	1.00	1.37	1.25
0.50	0.63	1.16	1.25

*V1011 and V1012 are housed in a different case.

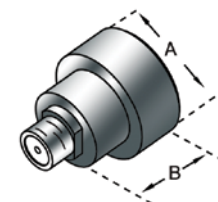

Transducer Dimensions (in inches)		
Nominal Element Size	(A)	(B)
0.50	0.81	0.63
0.25	0.50	0.42

Dual Element Transducers

A dual element transducer consists of two crystal elements housed in the same case, separated by an acoustic barrier. One element transmits longitudinal waves, and the other element acts as a receiver.

For information on transducers for corrosion applications, see "Dual Element Transducers for Thickness Gages" starting on page 30.

Advantages

- Improves near-surface resolution
- Eliminates delay line multiples for high-temperature applications
- Couples well on rough or curved surfaces
- Reduces direct back-scattering noise in coarse-grained or scattering materials
- Combines the penetration capabilities of a lower frequency single element transducer with the near-surface resolution capabilities of a higher frequency single element transducer
- Can be contoured to conform to curved parts

Applications

- Remaining wall thickness measurement
- Corrosion/erosion monitoring
- Weld overlay and cladding bond/disbond inspection
- Detection of porosity, inclusions, cracks, and laminations in castings and forgings
- Crack detection in bolts or other cylindrical objects
- Maximum temperature capability is 800 °F (425 °C) for 5.0 MHz and below; 350 °F (175 °C) for 7.5 MHz and 10 MHz; recommended duty cycle for surface temperatures from 200 °F (90 °C) to 800 °F (425 °C) is ten seconds maximum contact followed by a minimum of one minute air cooling (does not apply to Miniature Tip Dual)

Flush Case Duals

- Metal wear ring extends transducer life
- Wear indicator references when the transducer face needs resurfacing
- Knurled, 303 stainless steel case
- Replaceable cable design (special dual cables with strain relief available)

Frequency MHz	Nominal Element Size		Transducer Part Numbers
	in.	mm	
1.0	0.50	13	DHC703-RM
2.25	0.50	13	DHC706-RM
	0.25	6	DHC785-RM
5.0	0.50	13	DHC709-RM
	0.25	6	DHC711-RM
10	0.25	6	DHC713-RM

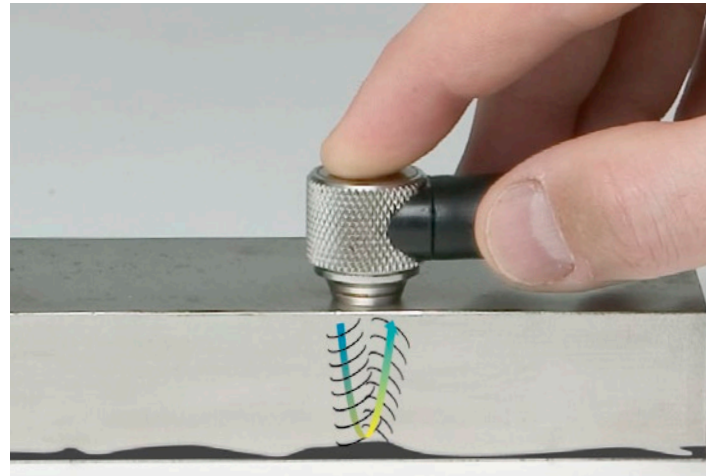

Two angled elements create a V-shaped sound path in the test material. This pseudo-focus enhances resolution in the focal zone.

Flush Case Dual Cables

Cable Part Number	Fits Connector Style
BCMD-316-5F	Dual BNC to Microdot
L1CMD-316-5F	Dual Large LEMO 1 to Microdot
LCMD-316-5F	Dual Flying Small LEMO 00 to Microdot



Composite Element Flush Case Duals

Frequency MHz	Nominal Element Size		Transducer Part Number
	in.	mm	
2.25	0.50	13	CHC706-RM

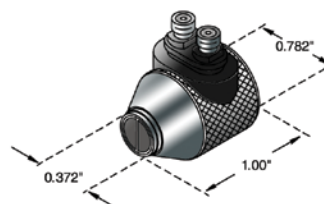

0.25 in. Element Size

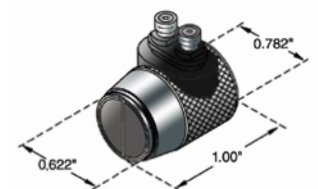

0.50 in. Element Size

Fingertip Duals

- Knurled case, except the 0.25 in. (6 mm) element size
- High-strength, flexible 6 ft (1.8 m) potted cable (fits BNC or large LEMO® 1 connectors)

Frequency MHz	Nominal Element Size		Transducer Part Numbers	
	in.	mm	Fits BNC Connector	Fits Large LEMO Connector
1.0	0.75	19	D714-RP	D714-RPL1
	0.50	13	D703-RP	D703-RPL1
2.25	0.75	19	D705-RP	D705-RPL1
	0.50	13	D706-RP	D706-RPL1
	0.375	10	D771-RP	D771-RPL1
	0.25	6	D785-RP	D785-RPL1
3.5	0.75	19	D781-RP	D781-RPL1
	0.50	13	D782-RP	D782-RPL1
	0.375	10	D783-RP	D783-RPL1
	0.25	6	D784-RP	D784-RPL1
5.0	0.75	19	D708-RP	D708-RPL1
	0.50	13	D709-RP	D709-RPL1
	0.375	10	D710-RP	D710-RPL1
	0.25	6	D711-RP	D711-RPL1
7.5	0.50	13	D720-RP	D720-RPL1
	0.25	6	D721-RP	D721-RPL1
10	0.50	13	D712-RP	D712-RPL1
	0.25	6	D713-RP	D713-RPL1

Miniature Tip Dual

- Provides better coupling on curved surfaces
- Low profile allows for better access in areas of limited space
- Maximum temperature capability 122 °F (50 °C)

Frequency MHz	Tip Diameter		Nominal Element Size		Transducer Part Number
	in.	mm	in.	mm	
5.0	0.20	5	0.15	3.8	MTD705

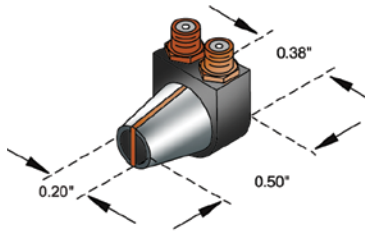

Miniature Tip Dual Cables

- Replaceable cable for all flaw detectors

Cable Part Number	Fits Connector Style
BCLPD-78-5	Dual BNC to Lepra/Con
L1CLPD-78-5	Dual Large LEMO 1 to Lepra/Con
LCLPD-78-6N	Dual Flying Small LEMO 00 to Lepra/Con

Extended Range Duals

- Shallow roof angles provide greater sensitivity to deep flaws, back walls, and other reflectors, 0.75 in. (19 mm) and beyond in steel
- Can be used for high-temperature measurements when delay lines are unacceptable
- High-strength, flexible 6 ft (1.8 m) potted cable with BNC connectors

Frequency MHz	Nominal Element Size		Roof Angle	Transducer Part Numbers
	in.	mm	(°)	
2.25	1.00	25	0	D7079
	0.50	13	0	D7071
	0.50	13	1.5	D7072
	0.50	13	2.6	D7074
5.0	0.50	13	3.5	D7073
	1.00	25	0	D7080
	0.50	13	0	D7075
	0.50	13	1.5	D7076
	0.50	13	2.6	D7078
	0.50	13	3.5	D7077

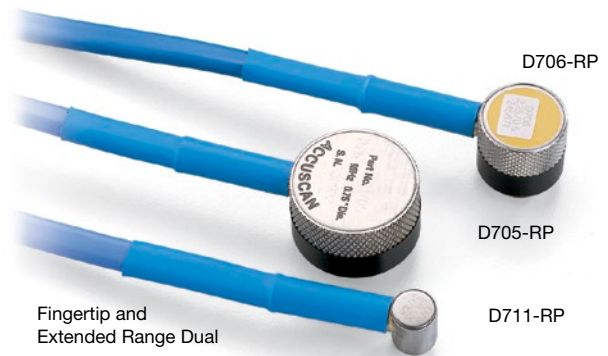

Transducer Dimensions (in inches)

Nominal Element Size	(A)	(B)	(C)
1.00*	1.25	0.75	1.00
0.75	1.00	0.75	0.75
0.50	0.70	0.75	0.50
0.50*	0.70	0.63	0.61
0.375	0.53	0.62	0.375
0.25	0.35	0.54	0.25

* Extended Range Duals

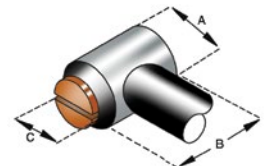

Angle Beam Transducers and Wedges

Angle beam transducers have a single element and are used with a wedge to introduce a refracted shear wave or longitudinal wave into a test piece.

Advantages

- Three-material design of our Accupath wedges improves signal-to-noise characteristics while providing excellent wear resistance
- High-temperature wedges available for in-service inspection of hot materials
- Accupath wedges can be customized to create nonstandard refracted angles
- Available in interchangeable or integral designs
- Contouring available for select wedge types, including Accupath
- Wedges and integral designs are available with standard refracted angles in aluminum (see "Shear Wave Wedges for Aluminum" on page 15)

Applications

- Flaw detection and sizing
- For time-of-flight diffraction transducers, see "TOFD Transducers" on page 35
- Inspection of pipes, tubes, forgings, castings, as well as machined and structural components for weld defects or cracks

Miniature Screw-In Transducers

- Screw-in design 303 stainless steel case
- Transducers are color coded by frequency
- Compatible with Short Approach, Accupath, High-Temperature, and Surface Wave Wedges

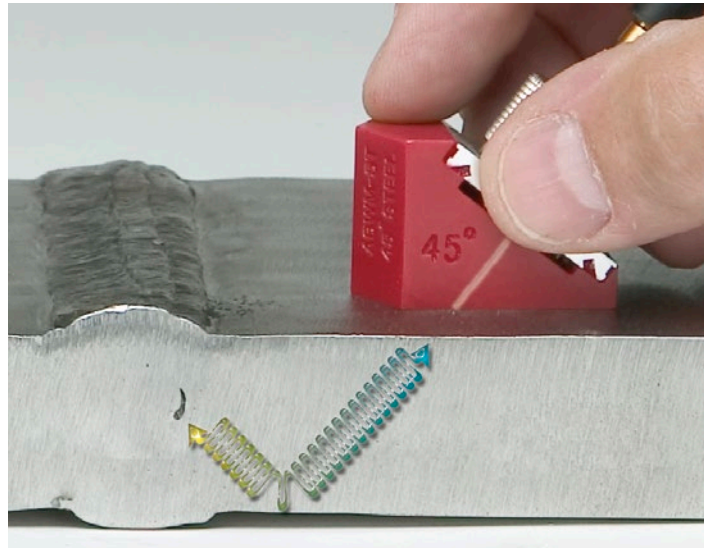

Miniature angle beam transducers and wedges are used primarily for testing weld integrity. Their design enables them to be easily scanned back and forth and provides a short approach distance.

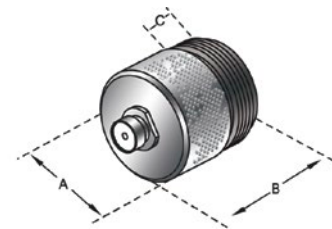

Nominal Element Size		Frequency	Transducer Part Numbers		
in.	mm		ACCUSCAN-S	CENTRASCAN	VIDEOSCAN
0.50	13	1.0	A539S-SM	C539-SM	V539-SM
		2.25	A540S-SM	C540-SM	V540-SM
		3.5	A545S-SM	C545-SM	V545-SM
		5.0	A541S-SM	C541-SM	V541-SM
		10.0	A547S-SM	—	V547-SM
0.375	10	1.0	—	C548-SM	—
		1.5	A548S-SM	—	—
		2.25	A549S-SM	C549-SM	V549-SM
		3.5	A550S-SM	C550-SM	V550-SM
		5.0	A551S-SM	C551-SM	V551-SM
0.25	6	2.25	A542S-SM	C542-SM	V542-SM
		3.5	A546S-SM	C546-SM	V546-SM
		5.0	A543S-SM	C543-SM	V543-SM
		10	A544S-SM	C544-SM	V544-SM

Transducer Dimensions (in inches)

Nominal Element Size	(A)	(B)	(C)	Thread Pitch
0.50	0.71	0.685	0.257	1/16 - 24
0.375	0.58	0.65	0.257	9/16 - 24
0.25	0.44	0.55	0.22	3/8 - 32

Short Approach Wedges

- Smallest footprint
- Short approach distance enables inspection close to the weld crown

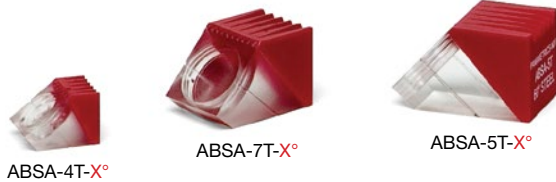

Accupath Wedges

- Small wedge footprint
- Pointed toe design enables transducer rotation even when the nose is touching a weld crown
- Special wedge design for use with a 10 MHz transducer



Miniature Screw-In Wedges for 1–5 MHz

Nominal Element Size		Wedge Part Numbers					
in.	mm	Short Approach†	Accupath*	High Temp* 500 °F (260 °C)	Very High Temp* 900 °F (480 °C)	Surface Wave 90°	Scanner Compatible**
0.50	13	ABSA-5T-X°	ABWM-5T-X°	ABWHT-5T-X°	ABWVHT-5T-X°	ABWML-5T-90°	SPE3-XXS-IHC
0.375	10	ABSA-7T-X°	ABWM-7T-X°	ABWHT-7T-X°	ABWVHT-7T-X°	ABWML-7T-90°	SPE2-XXS-IHC
0.25	6	ABSA-4T-X°	ABWM-4T-X°	ABWHT-4T-X°	ABWVHT-4T-X°	ABWML-4T-90°	SPE1-XXS-IHC

† Short Approach wedges are available in standard refracted shear wave angles of 45°, 60°, and 70° in steel at 5.0 MHz.

*Accupath wedges are available in standard refracted shear wave angles of 30°, 45°, 60°, and 70° in steel at 5.0 MHz.

Custom refracted longitudinal and transverse wave wedges for other materials may be available on request.

**SPE wedges are available in standard refracted shear wave angles of 45°, 60°, and 70° in steel.

Miniature Screw-In Wedges for 10 MHz Transducers

Nominal Element Size		Wedge Part Numbers		
in.	mm	Accupath*	Surface Wave 90°	Scanner Compatible**
0.50	13	ABWM-5ST-X°	ABWML-5ST-90°	SPE3-XXS-IHC
0.375	10	ABWM-7ST-X°	ABWML-7ST-90°	SPE2-XXS-IHC
0.25	6	ABWM-4ST-X°	ABWML-4ST-90°	SPE1-XXS-IHC

*Accupath wedges are available in standard refracted shear wave angles of 30°, 45°, 60°, and 70° in steel at 10 MHz.

**SPE wedges are available in standard refracted shear wave angles of 45°, 60°, and 70° in steel.

Short Approach Wedge Dimensions (Miniature Screw-In)
Fits Nominal Element Size (in inches)

	0.5				0.375				0.25			
	(A)	(B)	(C)	(D)	(A)	(B)	(C)	(D)	(A)	(B)	(C)	(D)
45°	0.70	1.03	0.73	0.38	0.60	0.85	0.61	0.32	0.43	0.61	0.43	0.24
60°	0.74	1.19	0.73	0.45	0.67	1.00	0.61	0.37	0.48	0.71	0.43	0.27
70°	0.79	1.34	0.73	0.50	0.69	1.12	0.61	0.41	0.50	0.81	0.43	0.31

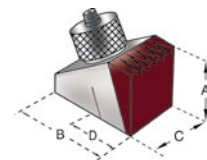

Accupath and Surface Wave Wedge Dimensions* (Miniature Screw-In)
Fits Nominal Element Size (in inches)

	0.5				0.375				0.25			
	(A)	(B)	(C)	(D)	(A)	(B)	(C)	(D)	(A)	(B)	(C)	(D)
30°	0.72	1.22	0.77	0.54	0.62	1.03	0.65	0.42	0.49	0.66	0.45	0.23
45°	0.85	1.31	0.77	0.49	0.76	1.14	0.65	0.41	0.53	0.74	0.45	0.24
60°	1.00	1.66	0.77	0.66	0.87	1.41	0.65	0.52	0.63	0.95	0.45	0.32
70°	1.00	1.82	0.77	0.73	0.92	1.52	0.65	0.51	0.66	1.08	0.45	0.36
90°	1.25	1.84	0.77	—	1.00	1.48	0.65	—	0.83	1.13	0.45	—

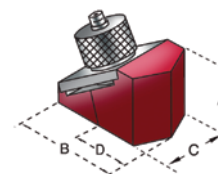

*Wedge dimensions for 10 MHz transducers are slightly different; please consult us for details.

Standard Angle Beam Transducers and Wedges

- Large element size enables inspection of thicker components and provides a large scanning index
- Transducers available in Accuscan-S, Centrascan®, and Videoscan® series
- Accupath and high-temperature style wedges available
- Threaded brass screw receptacles ensure firm anchoring of the transducer onto the wedge
- Available in frequencies as low as 0.5 MHz and 1.0 MHz
- Captive screws included with the transducer

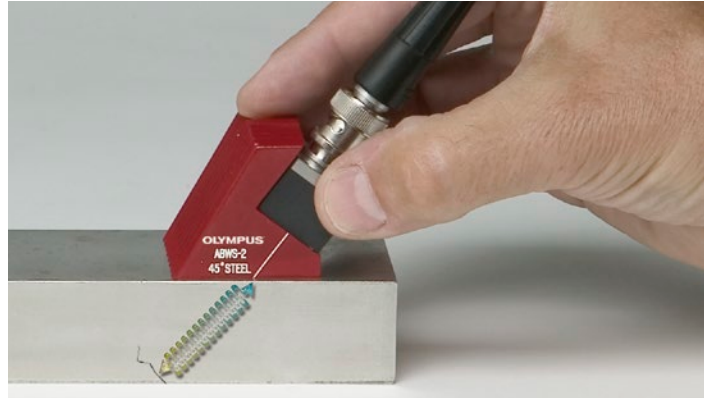

Standard Angle Beam transducers and wedges offer a large scanning index, which allows for a shorter scan time on larger test surfaces.

Nominal Element Size		Frequency	Transducer Part Numbers			Wedge Part Numbers			
in.	mm	MHz	ACCUSCAN-S	CENTRASCAN	VIDEOSCAN	Accupath*	High Temp* 500 °F (260 °C)	Very High Temp* 900 °F (480 °C)	Surface Wave 90°
1.00	25	0.5	A414S-SB	—	V414-SB	ABWS-3-X°	ABWHT-3-X°	ABWVHT-3-X°	ABWSL-3-90°
		1.0	A407S-SB	C407-SM	V407-SB				
		2.25	A408S-SB	C408-SB	V408-SB				
		3.5	A411S-SB	C411-SB	—				
		5.0	A409S-SB	—	V409-SB				
0.50 × 1.00	13 × 25	0.5	A413S-SB	—	V413-SB	ABWS-2-X°	ABWHT-2-X°	ABWVHT-2-X°	ABWSL-2-90°
		1.0	A401S-SB	C401-SB	V401-SB				
		2.25	A403S-SB	C403-SB	V403-SB				
		3.5	A412S-SB	C412-SB	—				
		5.0	A405S-SB	C405-SB	V405-SB				
0.50	13	1.0	A402S-SB	C402-SB	V402-SB	ABWS-1-X°	ABWHT-1-X°	ABWVHT-1-X°	ABWSL-1-90°
		2.25	A404S-SB	C404-SB	V404-SB				
		3.5	A415S-SB	C415-SB	—				
		5.0	A406S-SB	C406-SB	V406-SB				

*Wedges are available in standard refracted shear wave angles of 30°, 45°, 60°, and 70° in steel at 5.0 MHz.

For 0.5 × 1 in. probes, the ABWX-2001 variable angle beam wedge enables the user to adjust the incident angle from 0° to 50° to create refracted angles in steel from 0° to 90°.

For replacement screws, use part number NPD-053-0104

Accupath and Surface Wave Wedge Dimensions (Standard)
Nominal Element Size (in inches)

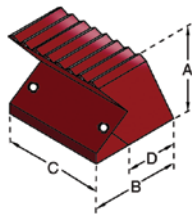

	1.00				0.50 × 1.00				0.50			
	(A)	(B)	(C)	(D)	(A)	(B)	(C)	(D)	(A)	(B)	(C)	(D)
30°	1.69	2.15	1.62	1.15	1.30	1.30	1.60	0.76	1.20	1.42	1.10	0.83
45°	1.47	1.96	1.63	0.97	1.30	1.41	1.60	0.78	1.20	1.31	1.08	0.70
60°	1.50	2.18	1.63	1.00	1.30	1.50	1.60	0.67	1.20	1.48	1.08	0.68
70°	1.50	2.47	1.63	1.13	1.35	1.77	1.60	0.85	1.20	1.58	1.09	0.68
90°	1.50	2.50	1.65	0.44	1.20	1.34	1.60	—	1.20	1.34	1.00	—

Dimension A = Wedge Height
Dimension D = Approach Distance



Transducer Dimensions (in inches)

Nominal Element Size	(A)	(B)	(C)	(D)
1.00	1.25	0.63	1.38	1.65
0.50 × 1.00	0.73	0.63	1.31	1.53
0.50	0.72	0.63	0.81	1.02

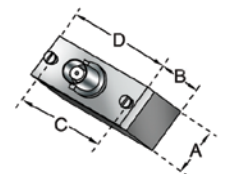

Integral Angle Beam Transducers

- Durable plastic wear surface extends transducer life and minimizes the chance of scratching critical components
- Small approach distance and overall transducer height provides an excellent choice for limited access applications
- Superior signal-to-noise characteristics for such small integral transducers
- Finger ring included with Micro-Miniature-RM case style transducers



A592S-SM



A592S-RM

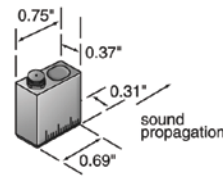

0.25 in. SM style for aluminum

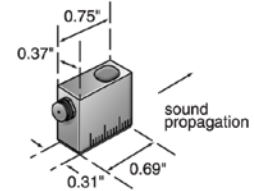

0.25 in. RM style for aluminum

Transducer Case	Nominal Element Size		Frequency MHz	Material	Connector Style	Transducer Part Numbers			
	in.	mm				45°	60°	70°	90°
Miniature	0.25 × 0.25	6 × 6	2.25	Steel	RM	A561S-RM	A562S-RM	A563S-RM	A564S-RM*
			5.0	Steel	RM	A571S-RM	A572S-RM	A573S-RM	A574S-RM*
			5.0	Aluminum	RM or SM	A591S	A592S	A593S	see note*
Micro-Miniature	0.187 × 0.187	5 × 5	2.25	Steel	RM	A5050	—	—	A5053*
			5.0	Steel	RM	A5020	A5023	A5021	—
			5.0	Steel	SM	A5015	A5014	A5013	—
			5.0	Aluminum	SM	A5067	A5068	A5069	see note*
			10	Steel	SM	—	—	A5054	—

*A564S-RM, A574S-RM, and A5053 create surface waves in steel and aluminum.

0.187 in., RM Style

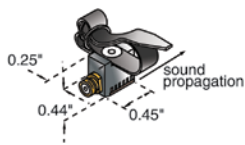

A5023



0.187 in., SM Style

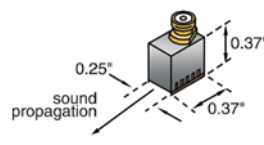

A5014



0.25 in., RM Style for Steel

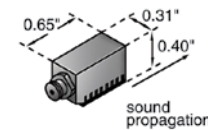

A564S-RM



Shear Wave Wedges for Aluminum

- Compatible with our Miniature Screw-In and Standard Angle Beam transducers

Transducer Case	Nominal Element Size		Wedge Part Numbers				
	in.	mm	30°	45°	60°	70°	90°
Screw-In	0.50	13	ABWM-5053T	ABWM-5027T	ABWM-5028T	ABWM-5029T	ABWML-5041T
	0.375	10	ABWM-7024T	ABWM-7025T	ABWM-7026T	ABWM-7027T	ABWML-7028T
	0.25	6	ABWM-4086T	ABWM-4087T	ABWM-4088T	ABWM-4089T	ABWML-4074T
Standard	1.00	25	ABWS-3028	ABWS-3016	ABWS-3029	ABWS-3030	ABWSL-3039
	0.50 × 1.00	13 × 25	ABWS-2021	ABWS-2022	ABWS-2023	ABWS-2024	ABWSL-2056
	0.50	13	ABWS-1033	ABWS-1034	ABWS-1035	ABWS-1036	ABWSL-1045

Contoured Wedges

- Improve coupling on curved surfaces
- When ordering, please specify wedge type, contour orientation, and contour diameter
- Example Part #: ABWM-4T-45-COD1.25IN
- Some wedge styles, such as the ABSA, cannot be offered with contours or custom angles

AWS Wedges and Transducers

- Transducers and wedges meet or exceed the specifications as set forth by the AWS Code Section D1.1
- Snail wedges use industry accepted hole spacing
- Captive screws included with the transducer
- Accupath style wedges marked with a five line graticule to assist in locating the beam exit point

Nominal Element Size	Frequency	Transducer Part Numbers		Snail Wedge Part Number*
		ACCUSCAN	CENTRASCAN	
0.625 × 0.625	2.25	A430S-SB	C430-SB	ABWS-8 -X°
0.625 × 0.75		A431S-SB	C431-SB	
0.75 × 0.75		A432S-SB	C432-SB	

* Wedges are available in standard refracted shear wave angles of 45°, 60°, and 70° in steel. Please specify when ordering. For replacement screws, use part number NPD-053-0162.



Snail Wedges

	Snail Wedge Dimensions* (in inches)			
	(A)	(B)	(C)	(D)
45°	2.15	0.62	1.78	1.25
60°	1.91	0.65	1.81	1.25
70°	2.17	0.67	1.92	1.25

*Distance between screws (center to center) is 1.00 in.

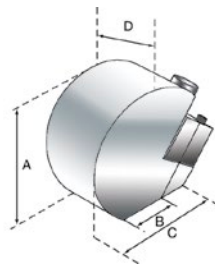

Accupath Wedges

	Accupath Wedge Dimensions* (in inches)			
	(A)	(B)	(C)	(D)
45°	1.50	0.90	1.96	1.50
60°	1.68	0.79	2.05	1.50
70°	1.66	0.96	2.20	1.50

*Distance between screws (center to center) is 1.062 in.

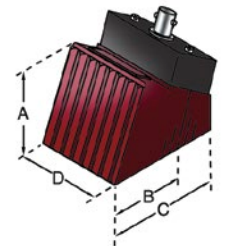

CDS Wedges

CDS Wedges are used in the "30-70-70" technique for crack detection and sizing on stainless steel. They are compatible with our replaceable miniature screw-in angle beam transducers, making them an economical alternative to other commercially available products. For information on transducers, see Miniature Screw-In Transducers on "Angle Beam Transducers and Wedges" starting on page 12.

Fits Nominal Element Size		Wedge Part Number
in.	mm	
0.25	6	CDS-4T
0.375	10	CDS-7T

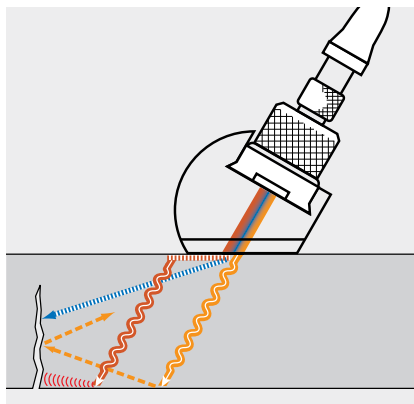

Understanding CDS

The 30-70-70 crack detection technique uses a single element transducer with a CDS wedge for detection and sizing of ID connected cracks. This technique uses a combination of three waves to size flaws at different depths in stainless steel.

- An OD creeping wave creates a 31.5-degree indirect shear (red in diagram to the left) wave, which mode converts to an ID creeping wave; this will produce a reflected signal on all ID connected cracks.
- A 30-degree shear wave (orange in diagram to the left) will reflect off the material ID at the critical angle and mode convert to a 70-degree longitudinal wave; a signal will be received by the transducer on mid-wall deep cracks
- A 70-degree longitudinal wave (blue in diagram to the left) will reflect off the tip of a deep wall crack

Based on the presence or absence of these three waves, both detection and sizing of ID connected cracks is possible.

Normal Incidence Shear Wave Transducers

Single element contact transducers introduce shear waves directly into the test piece without the use of refracted wave mode conversion.

Advantages

- Generate shear waves that propagate perpendicular to the test surface
- For ease of alignment, the direction of the polarization of shear wave is nominally in line with the right angle connector
- The ratio of the longitudinal to shear wave components is generally below -30 dB

Applications

- Shear wave velocity measurements
- Calculation of Young's modulus of elasticity and shear modulus
- Characterization of material grain structure

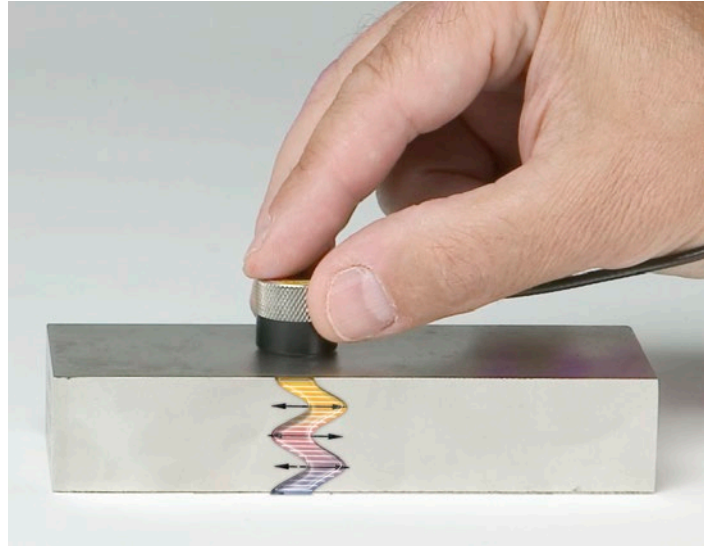

We recommend the use of our SWC shear wave couplant for general purpose testing.



Direct Contact Series

- Wear plate increases durability and wear resistance
- Available in both the Standard and Fingertip case styles
- 303 stainless steel case

Frequency MHz	Nominal Element Size		Transducer Part Numbers	
	in.	mm	Standard Case	Fingertip Case
0.1	1.00	25	V1548	—
0.25	1.00	25	V150-RB	V150-RM
0.5	1.00	25	V151-RB	V151-RM
1.0	1.00	25	V152-RB	V152-RM
	0.50	13	V153-RB	V153-RM
2.25	0.50	13	V154-RB	V154-RM
	0.50	13	V155-RB	V155-RM
5.0	0.25	6	—	V156-RM
	0.125	3	—	V157-RM

For dimensions, see "Contact Transducers" starting on page 8.

Delay Line Series

- Integral delay line permits measurements at higher frequencies
- Fused silica delay line minimizes attenuation and provides physical protection to the crystal element

Frequency MHz	Nominal Element Size		Delay μs.	Transducer Part Numbers
	in.	mm		
5.0	0.25	6	6.75	V220-BA-RM
10	0.25	6	6.75	V221-BA-RM
20	0.25	6	6.75	V222-BA-RM
	0.25	6	6.75	V222-BB-RM
	0.25	6	4.00	V222-BC-RM

For dimensions, see "High-Frequency Transducers" on page 28.

Shear Wave Couplant

SWC-2	2 oz (0.06 liter)	Normal Incidence Shear Wave, non-toxic, water soluble organic substance of very high viscosity
-------	-------------------	--

Delay Line Transducers

A replaceable delay line transducer is a single element contact transducer designed specifically for use with a replaceable delay line.

Advantages

- Heavily damped transducer combined with the use of a delay line provides excellent near-surface resolution
- Higher transducer frequency improves resolution
- Improves the ability to measure thin materials or find small flaws while using the direct contact method
- Contouring available to fit curved parts

Applications

- Precision thickness gaging
- Straight beam flaw detection
- Inspection of parts with limited contact areas
- Replaceable delay line transducers
- Each probe comes with a standard delay line and retaining ring
- High-temperature and dry couple delay lines are available
- Requires couplant between transducer and delay line tip



Frequency	Nominal Element Size		Transducer Part Numbers
	in.	mm	
2.25	0.25	6	V204-RM
5.0	0.50	13	V206-RM
	0.25	6	V201-RM
10	0.25	6	V202-RM
	0.125	3	V203-RM
15	0.25	6	V205-RM
20	0.125	3	V208-RM

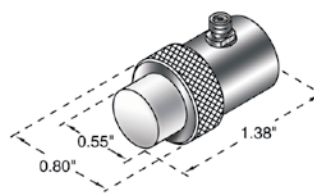
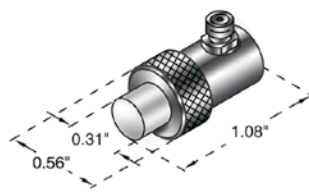
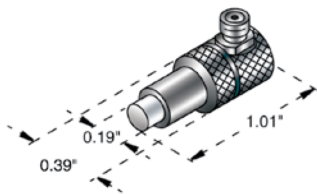

Replaceable Delay Line Options

Nominal Element Size		Standard Delay Line	Standard Delay Length	High Temperature			Dry Couple Delay Line	Spare Retaining Ring	Spring-Loaded Holders
				350 °F max. (175 °C)	500 °F max. (260 °C)	900 °F max. (480 °C)			
0.50 in.	13 mm	DLH-2	0.50 in.	DLHT-201	DLHT-2	DLHT-2G	DLS-2	DRR-2	—
0.25 in.	6 mm	DLH-1	0.45 in.	DLHT-101	DLHT-1	DLHT-1G	DLS-1	DRR-1	2127 & DRR-1H
0.125 in.	3 mm	DLH-3	0.22 in.	DLHT-301	DLHT-3	DLHT-3G	DLS-3	DRR-3	2133 & DRR-3H

Cylindrically contoured delay lines may be available on request.
Alternate delay line lengths may be available on request.

DLP-301



V260-45



V260-SM



V260-RM

Sonopen® Replaceable Delay Line Transducer

- Focused replaceable delay line
- Extremely small tip diameter may improve performance on curved surfaces and small indentations
- Handle for easier positioning of transducer head

Frequency	Nominal Element Size		Transducer Part Numbers		
	MHz	in.	mm	Straight Handle	Right Angle Handle
15	0.125	3	V260-SM	V260-RM	V260-45

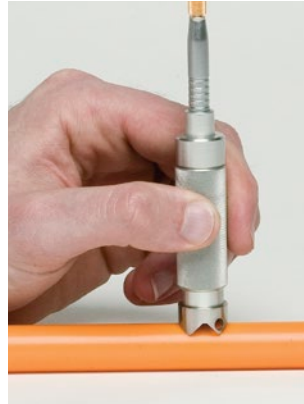

Sonopen Replaceable Delay Lines

Tip diameter		Part Number
in.	mm	
0.080	2.0	DLP-3
0.060	1.5	DLP-302
0.080	2.0	DLP-301*

* High-temperature delay for use up to 350°F (175°C)

Spring-Loaded Holder

SLH-V260-SM*

* For use with V260-SM only.

Permanent Delay Line Transducers with Handle Assembly

These transducers are used to reach into areas of limited access such as adjacent turbine blades. The swivel head improves contact in tight areas.

Frequency	Nominal Element Size		Delay Line Length	Transducer Part Number
	MHz	in.		
20	0.125	3	1.5	M2054
20	0.125	3	4.5	M2055
20	0.125	3	4.0	V2034

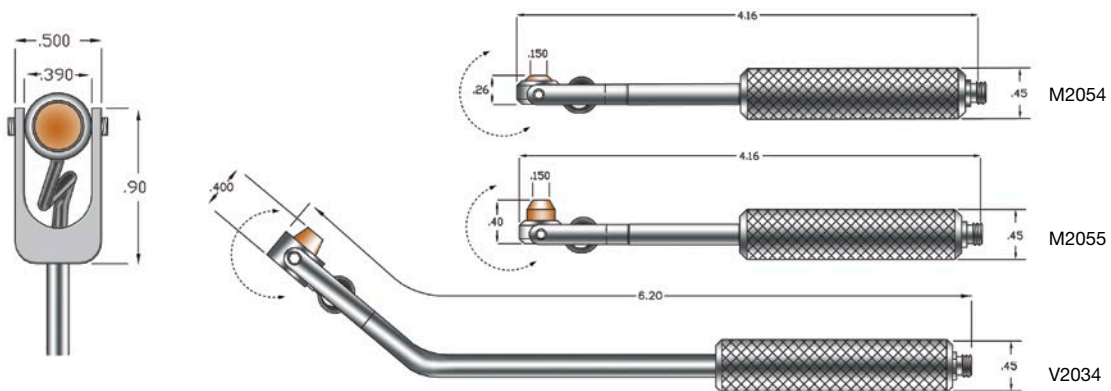

Protected Face Transducers

A protected face transducer is a single element longitudinal wave contact transducer that can be used with either a delay line, protective membrane, or protective wear cap.

Advantages

- Provides versatility by offering a removable delay line, protective wear cap, and protective membrane
- When the transducer is used alone (without any of the options), the epoxy wear face provides good acoustic impedance matching into plastics, many composites, and other low-impedance materials (cannot be used directly on hard surfaces)
- Cases are threaded for easy attachment to the delay line, protective membrane, and wear cap options

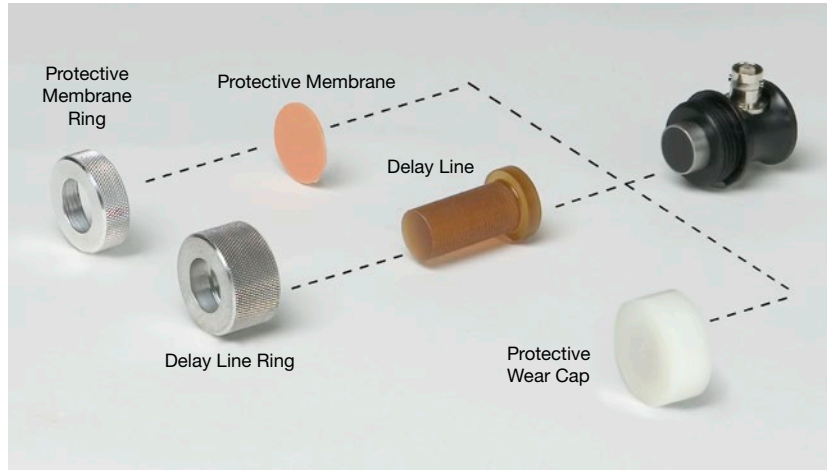

Applications

- Straight beam flaw detection
- Thickness gaging
- High-temperature inspections
- Inspection of plates, billets, bars, and forgings

Standard Protected Face

- Comfort fit sleeves are designed to be easily held and provide steady grip while wearing gloves
- Standard connector style Right Angle BNC (RB); may be available in Straight BNC (SB)
- Delay line, protective membrane, and wear cap options sold separately from the transducer



Frequency	Nominal Element Size		Transducer Part Numbers		
	MHz	in.	mm	ACCUSCAN-S	CENTRASCAN
0.5	1.50	38	A689S-RB	—	V689-RB
	1.00	25	A601S-RB	—	V601-RB
1.0	1.50	38	A692S-RB	—	V692-RB
	1.00	25	A602S-RB	C602-RB	V602-RB
	0.75	19	A614S-RB	—	V614-RB
	0.50	13	A603S-RB	C603-RB	V603-RB
2.25	1.50	38	A695S-RB	—	V695-RB
	1.00	25	A604S-RB	C604-RB	V604-RB
	0.75	19	A605S-RB	—	V605-RB
	0.50	13	A606S-RB	C606-RB	V606-RB
3.5	1.00	25	A680S-RB	—	V680-RB
	0.75	19	A681S-RB	—	V681-RB
	0.50	13	A682S-RB	—	V682-RB
5.0	1.00	25	A607S-RB	—	V607-RB
	0.75	19	A608S-RB	—	V608-RB
10	0.75	19	A609S-RB	C609-RB	V609-RB
	0.50	13	A611S-RB	—	V611-RB

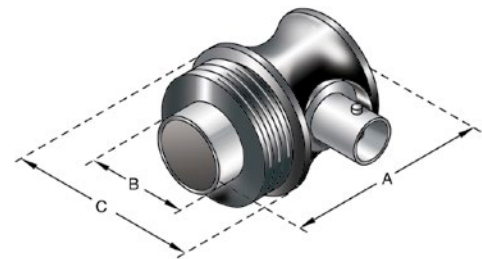

Transducer Dimensions (in inches)			
Nominal Element Size	(A)	(B)	(C)
1.50	1.53	1.75	2.25
1.125	1.53	1.38	1.81
1.00	1.53	1.25	1.63
0.75	1.53	0.99	1.41
0.50	1.53	0.63	1.19

1.125 in. element diameter 0.5, 1.0, and 2.25 MHz probes may be available upon request.

High-Temperature Delay Line Options

- Allows for intermittent contact with hot surfaces*
- Improves near-surface resolution
- Contouring of delay lines provides better coupling on curved surfaces
- Warm temperature delay lines (WTD) can be used for room temperature applications

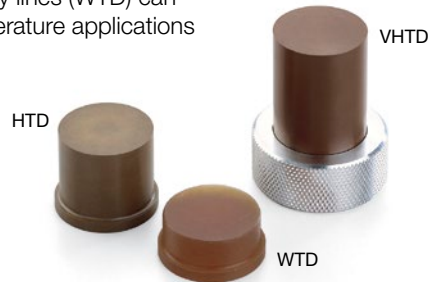

Nominal Element Size		Delay Line Retaining Ring	350 °F max. (175 °C)	500 °F max. (260 °C)	900 °F max. (480 °C)
in.	mm				
1.00	25	DRN-3	WTD-3-x	HTD-3-x	VHTD-3-x
0.75	19	DRN-4	WTD-4-x	HTD-4-x	VHTD-4-x
0.50	13	DRN-5	WTD-5-x	HTD-5-x	VHTD-5-x

*Recommended usage cycle is ten seconds maximum contact followed by one minute of air cooling. However, the transducer itself should not be heated above 122 °F (50 °C).

X = standard delay line lengths, available in ½ in. (13 mm), 1 in. (25 mm), 1-½ in. (38 mm). Specify at time of ordering.

Note: For the delay lines above, a room temperature material longitudinal wave velocity of 0.100 in./µsec ±0.005 in./µsec may be used as an approximation for basic calculations. This value should not be used for engineering design calculations. Contact us for details.



Protective Membrane Option

- Improves coupling on rough or uneven surfaces
- Dry couple to smooth, clean surfaces

Nominal Element Size		Membranes Only*		Membrane Retaining Ring	Kits†
in.	mm	pkg of 12	pkg of 60		
1.50	38	PM-1-12	PM-1-60	MRN-1	PMK-1
1.125	29	PM-2-12	PM-2-60	MRN-2	PMK-2
1.00	25	PM-3-12	PM-3-60	MRN-3	PMK-3
0.75	19	PM-4-12	PM-4-60	MRN-4	PMK-4
0.50	13	PM-5-12	PM-5-60	MRN-5	PMK-5

*Available in 36 in. x 36 in. x 1/32 in. sheets. Order part number NPD-665-3101.

† Kit includes 12 membranes, 1 ring, and B2 couplant.

Couplant must be used between the probe face and the attached accessory.



Protective Wear Cap Option

- The nylon wear cap provides an economical solution in applications requiring scanning or scrubbing of rough surfaces

Nominal Element Size		Protective Wear Caps
in.	mm	
1.50	38	NWC-1
1.125	29	NWC-2
1.00	25	NWC-3
0.75	19	NWC-4
0.50	13	NWC-5

Immersion Transducers

An immersion transducer is a single element longitudinal wave transducer with a 1/4 wavelength layer acoustically matched to water. It is specifically designed to transmit ultrasound in applications where the test part is partially or wholly immersed.

Advantages

- The immersion technique provides uniform coupling
- Quarter wavelength matching layer increases sound energy output
- Corrosion resistant 303 stainless steel case with chrome-plated brass connectors
- Proprietary RF shielding for improved signal-to-noise characteristics in critical applications
- All immersion transducers, except paintbrush, can be focused spherically (spot) or cylindrically (line) (see the immersion transducers section of our technical notes)
- Customer specified focal length concentrates the sound beam to increase sensitivity to small reflectors

Applications

- Automated scanning
- On-line thickness gaging
- High-speed flaw detection in pipe, bar, tube, plate, and other similar components
- Time-of-flight and amplitude based-imaging
- Through-transmission testing
- Material analysis and velocity measurements

Usage Note: Transducers should not be submerged for periods exceeding 8 hours. Allow 16 hours of dry time to ensure the life of the unit.

Standard Case

- Knurled case with Straight UHF connector (SU)
- Contact us for nonknurled case design and availability of other connector styles
- Frequencies ranging from 1.0 to 25 MHz

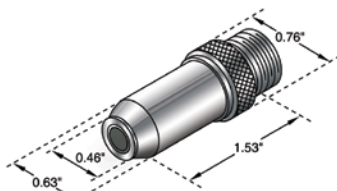

0.25 in. Element Standard Case Style

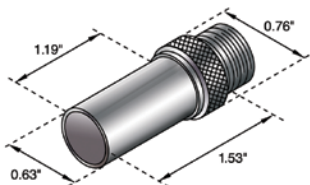

0.375 in. and 0.50 in. Element Standard Case Style

For more technical information, please refer to the Focusing Configurations and Table of Near Field Distance found in the "Ultrasonic Transducer Technical Notes".

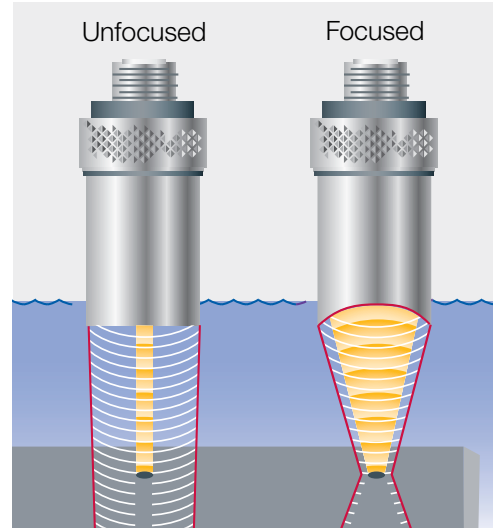

If a focus is required, select a focal length between min. and max.

Frequency MHz	Nominal Element Size		Unfocused Transducer Part Numbers			Point Target Focus (in inches)*	
	in.	mm	ACCUSCAN-S	CENTRASCAN	VIDEOSCAN	Min.	Max.
1.0	0.50	13	A303S-SU	—	V303-SU	0.60	0.80
	0.50	13	A306S-SU	C306-SU	V306-SU	0.80	1.90
2.25	0.375	10	—	C325-SU	V325-SU	0.50	1.06
	0.25	6	—	C323-SU	V323-SU	0.35	0.45
3.5	0.50	13	A382S-SU	C382-SU	V382-SU	0.83	2.95
	0.375	10	—	C383-SU	V383-SU	0.60	1.65
5.0	0.25	6	—	C384-SU	V384-SU	0.39	0.70
	0.50	13	A309S-SU	C309-SU	V309-SU	0.75	4.20
7.5	0.375	10	A326S-SU	C326-SU	V326-SU	0.60	2.35
	0.25	6	A310S-SU	C310-SU	V310-SU	0.43	1.00
10	0.50	13	A320S-SU	—	V320-SU	0.75	6.30
	0.50	13	A311S-SU	—	V311-SU	0.75	8.40
15	0.375	10	A327S-SU	—	V327-SU	0.60	4.75
	0.25	6	A312S-SU	—	V312-SU	0.46	2.10
20	0.50	13	A319S-SU	—	V319-SU	0.75	11.75
	0.375	10	—	—	V328-SU	0.60	7.10
25	0.25	6	A313S-SU	—	V313-SU	0.50	3.15
	0.25	6	—	—	V317-SU	0.50	4.20
25	0.125	3	—	—	V316-SU	0.25	1.00
	0.25	6	—	—	V324-SU	0.50	5.25

* Please select a specific focus between min. and max.

Large-Diameter Case

- Large element diameters increase near-field length, enabling longer focal lengths
- Larger diameters can increase scanning index
- Low-frequency, large-element-diameter designs available for challenging applications

If a focus is required, select a focal length between min. and max.

Frequency	Nominal Element Size		Unfocused Transducer Part Numbers			Point Target Focus (in inches)*	
	in.	mm	ACCUSCAN-S	CENTRASCAN	VIDEOSCAN	Min.	Max.
0.5	1.50	38	A389S-SU	—	V389-SU	2.15	3.80
	1.00	25	A301S-SU	—	V301-SU	1.25	1.65
	0.75	19	—	—	V318-SU	0.78	0.93
1.0	1.50	38	A392S-SU	—	V392-SU	2.50	7.56
	1.00	25	A302S-SU	C302-SU	V302-SU	1.63	3.38
	0.75	18	A314S-SU	—	V314-SU	1.00	1.90
2.25	1.50	38	A395S-SU	—	V395-SU	2.70	14.50
	1.00	25	A304S-SU	C304-SU	V304-SU	1.88	7.60
	0.75	19	A305S-SU	C305-SU	V305-SU	1.00	4.30
3.5	1.00	25	A380S-SU	C380-SU	V380-SU	1.95	11.25
	0.75	19	A381S-SU	C381-SU	V381-SU	1.00	6.65
5.0	1.00	25	A307S-SU	—	V307-SU	1.95	14.40
	0.75	19	A308S-SU	C308-SU	V308-SU	1.00	9.50
7.5	0.75	19	A321S-SU	—	V321-SU	1.00	12.75
10	1.00	25	—	—	V322-SU	2.00	20.00
	0.75	19	A315S-SU	—	V315-SU	1.00	15.37

* Please select a specific focus between min. and max.

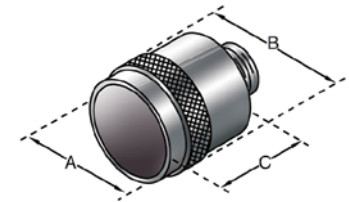

Transducer Dimensions (in inches)

Nominal Element Size	(A)	(B)	(C)
1.50	1.75	1.81	1.50
1.125	1.38	1.44	1.25
1.00	1.25	1.31	1.25
0.75	1.00	1.06	1.25

Slim Line Case

- Stainless steel case is only 0.38 in. (10 mm) in diameter, ideal for limited access areas
- Standard configuration is Straight and fits Microdot™ connector style

If a focus is required, select a focal length between min. and max.

Frequency	Nominal Element Size		Unfocused Transducer Part Numbers		Point Target Focus (in inches)*	
	in.	mm	ACCUSCAN-S	VIDEOSCAN	Min.	Max.
2.25	0.25	6	—	V323-SM	0.35	0.45
3.5	0.25	6	—	V384-SM	0.39	0.70
5.0	0.25	6	A310S-SM	V310-SM	0.43	1.00
10	0.25	6	A312S-SM	V312-SM	0.46	2.10
15	0.25	6	A313S-SM	V313-SM	0.50	3.15
20	0.25	6	—	V317-SM	0.50	4.20
	0.125	3	—	V316-SM	0.25	1.00
25	0.25	6	—	V324-SM	0.50	5.25

* Please select a specific focus between min. and max.

V312-SM

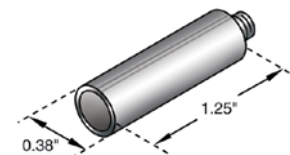

Replacement Microdot o-rings are available in packs of 10, part number NPD-151-3001.

Pencil Case

- Small-diameter, 2 in. (51 mm) long barrel improves access to difficult-to-reach areas
- Standard connector style is Straight UHF (SU)

Frequency	Nominal Element Size		Unfocused Transducer Part Numbers		Point Target Focus (in inches)*	
	MHz	in.	mm	ACCUSCAN-S	VIDEOSCAN	Min.
2.25	0.25	6	—	V323-N-SU	0.35	0.45
3.5	0.25	6	—	V384-N-SU	0.30	0.70
5.0	0.25	6	A310S-N-SU	V310-N-SU	0.43	1.00
10	0.25	6	A312S-N-SU	V312-N-SU	0.46	2.10
15	0.25	6	A313S-N-SU	V313-N-SU	0.50	3.15
20	0.25	6	—	V317-N-SU	0.50	4.20
	0.125	3	—	V316-N-SU	0.25	1.00
25	0.25	6	—	V324-N-SU	0.50	5.25

* Please select a specific focus between min. and max.

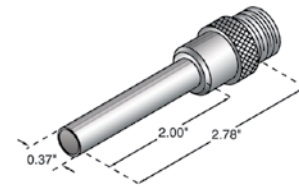

V316-N-SU

Side Looking Immersion Transducers

- Ideal for measuring the wall thicknesses of pipe where access to the outer diameter is limited
- Small outer diameter enables greater accessibility in tight spaces than standard immersion transducers with reflector mirrors
- Sound exit point is located at a 90° angle relative to the straight Microdot™ connector
- Probe extensions such as the F211 are available to lengthen the standard design

Part Numbers	Frequency	Nominal Element Size		Focus
	MHz	in.	mm	in.
V3591	10	0.125	3	0.50 OLF
V3343	20	0.125	3	0.50 OLF

Note: All above side looking immersion transducers have straight Microdot connectors.



V3343



Extra Miniature (XMS) Transducer

The XMS transducer is an extremely small 10 MHz immersion transducer with a 3 mm (0.118 in.) diameter by 3 mm (0.118 in.) long case. This transducer is ideal for extremely tight access areas or for multielement array flaw detection. The transducer assembly has a special connector attached to the 1 m (38 in.) long potted cable. An adaptor is also available to interface with most commercial ultrasonic equipment.

Frequency	Nominal Element Size		Part Number	Included Adaptor
	MHz	in.		
10	.080	2	XMS-310-B	BNC
10	.080	2	XMS-310-L	LEMO 1



XMS-310-B

Accuscan® Paintbrush

- Large scanning index is ideal for inspections of aluminum or steel plates
- Sensitivity uniformity of better than ± 1.5 dB is maintained across the transducer face (sensitivity peaks at the edges are also controlled)

Frequency	Nominal Element Size		Transducer Part Numbers
	in.	mm	
2.25	1.50 x 0.25	38 x 6	A330S-SU
3.5			A331S-SU
5.0			A332S-SU
7.5			A333S-SU
10			A334S-SU
2.25	2.00 x 0.25	51 x 6	A340S-SU
3.5			A341S-SU
5.0			A342S-SU
7.5			A343S-SU
10			A344S-SU

Note: Certification of beam uniformity is included with each transducer.

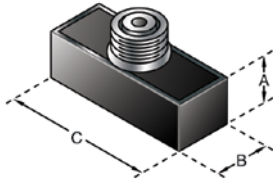

Transducer Dimensions
(in inches)

Nominal Element Size	(A)*	(B)	(C)
2.00 x 0.25	0.82	0.75	2.50
1.50 x 0.25	0.82	0.75	2.00

* For 7.5 MHz and 10 MHz, case height (A) is 0.62 in.



A334S-SU

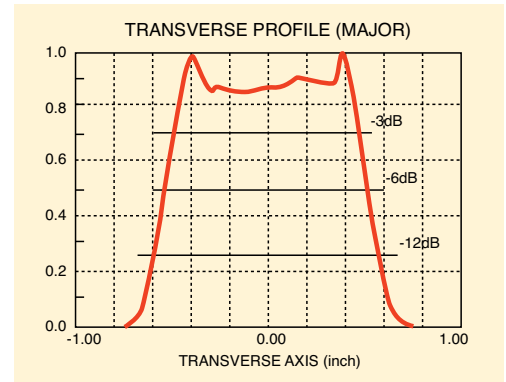

Reflector Mirrors

- Directs sound beam when a straight-on inspection is not possible
- Standard mirrors provide a 90° reflection of the sound beam

Case Style	Incident Angle	Part Numbers
Standard	45°	F102
Slim Line	45°	F132
Pencil	45°	F198

Note: Specialty reflector mirrors are available for the large diameter probes; F310 for 0.75in and F311 for 1.00in element diameters.



Immersion Search Tubes

- Provides a quick and easy way to fixture and manipulate immersion transducers

Part Numbers	Length		Fits Connector Styles	Outside Diameter	
	in.	mm		in.	mm
F112	1.5	38	UHF to UHF	0.738	18.75
F113	2	51	UHF to UHF	0.738	18.75
F114	3	76	UHF to UHF	0.738	18.75
F115	6	152	UHF to UHF	0.738	18.75
F116	8	203	UHF to UHF	0.738	18.75
F117	12	305	UHF to UHF	0.738	18.75
F118	18	457	UHF to UHF	0.738	18.75
F119	24	610	UHF to UHF	0.738	18.75
F120	30	762	UHF to UHF	0.738	18.75
F211	12	305	Microdot to Microdot	0.312	7.92



Bubblers

- Enables for immersion testing when complete immersion of parts is not desirable or possible
- Designed to maintain a consistent, low-volume flow of water



Part Numbers	Diameter Opening		Water Path		Case Style	Nominal Element Size		Opening Type
	in.	mm	in.	mm		in.	mm	
MPF-B-0.5	0.300	7.6	1.00	25.4	Standard SU†	0.125	3	flat
						0.25	6	flat
B103	0.350	8.9	0.775	19.7	Standard SU†	0.125	3	V-notch
						0.25	6	V-notch
B103A	0.350	8.9	0.475	12.1	Standard SU†	0.125	3	flat
						0.25	6	flat
B103W	0.550	14	0.775	19.7	Standard SU†	0.375	10	V-notch
						0.50	13	V-notch
B103AW	0.550	14	0.475	12.1	Standard SU†	0.375	10	flat
						0.50	13	flat
B116	0.100	2.5	variable, min. of:		Fits SU/RM case style*	0.125	3	flat
			0.075	1.9		0.25	6	flat
B117	1.375	34.4	1.400	35.6	Large Diameter	1.00	25.4	V-notch

* For more information on SU/RM case styles see "High-Frequency SU/RM Immersion Case" on page 29.
 † For more information on Standard SU case styles see "Standard Case" on page 22.

RBS-1 Immersion Tank

The RBS-1 immersion tank is designed to simplify testing measurements using immersion techniques. It consists of a clear acrylic tank, a submersible pump (only included for select regions), and a transducer fixture in a single, portable unit. The pump feeds an adjustable stream of water to a bubbler mounted in the fixture, providing a water column to couple sound from an immersion transducer into the test piece. It is ideal for offline thickness measurements on metal, glass, and plastic products such as small containers, pipe or tubing, sheets or plates, or machined parts.

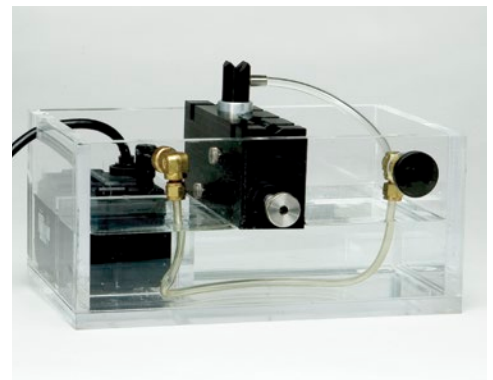

Clear Acrylic Tank

- (H x W x L) 5.5 in. x 8 in. x 12 in. (140 mm x 200 mm x 305 mm)
- 0.83 gallon (3.1 liter) capacity

Pump

- Up to 0.25 gallons (0.9 liters) per minute
- 115 or 230 V, 30 watt (voltage range 90 to 135 VAC), 50 to 60 Hz
- Submersible (ground fault interrupter circuit recommended)

Handheld Bubbler Transducer Assembly

Handheld bubbler transducers are available in either 20 MHz (V316B) or 10 MHz (V312B). They are immersion transducers that screw onto a bubbler assembly (B120) that has a replaceable stainless steel tip and a water feed tube. They offer high resolution and easy access inspection of thin materials. The V316B and bubbler combination can resolve thicknesses down to 0.008 in. (0.2 mm).

Frequency	Nominal Element Size		Focal Length		Transducer Part Number	Bubbler Assembly	Replacement Tip	Flexible Tip
	MHz	in.	mm	in.				
10	0.25	6	1.00	25	V312B-RM	B120	B120-TIP	B120-FLEX-TIP
20	0.125	3	0.75	19	V316B-RM	B120	B120-TIP	B120-FLEX-TIP



Spot Weld Transducers

A spot weld transducer is a single element delay line transducer compatible with either a hard tip delay line or captive water column specifically intended for testing the integrity of spot welds.

Advantages:

- Variety of element sizes for testing different size weld nuggets
- Compatible with either hard tip delay line or water column
- Engraved with both inches and millimeters

Applications:

- Automotive, appliances, and other critical industrial spot welds



Top Row:
Transducer, Water Column, Membranes
Bottom Row:
Transducer, Delay Line, Delay Line Retaining Ring

Select either a delay line or water column. (Transducers, delay lines, delay line retaining rings, water columns, and membranes need to be ordered separately.)

Transducer Part Number	Frequency Mhz	Diameter (mm)	Diameter (in.)	Delay Line* Choose Appropriate Diameter		Delay Line Retaining Ring	Water Column Order Membranes (Below)
V2325	15	2.5	0.098	SWDL-25 (2.5 mm)	SWDL-27 (2.7 mm)	SWRR-1	DLCW-1003
V2330	15	3	0.118	SWDL-30 (3.0 mm)	SWDL-32 (3.2 mm)	SWRR-1	DLCW-1003
V2335	15	3.5	0.138	SWDL-35 (3.5 mm)	SWDL-37 (3.7 mm)	SWRR-2	DLCW-2003
V2340	15	4	0.157	SWDL-40 (4.0 mm)	SWDL-42 (4.2 mm)	SWRR-2	DLCW-2003
V2345	15	4.5	0.177	SWDL-45 (4.5 mm)	SWDL-47 (4.7 mm)	SWRR-2	DLCW-2003
V2350	15	5	0.197	SWDL-50 (5.0 mm)	SWDL-52 (5.2 mm)	SWRR-2	DLCW-2003
V2355	15	5.5	0.217	SWDL-55 (5.5 mm)	SWDL-57 (5.7 mm)	SWRR-2	DLCW-2003
V2360	15	6	0.236	SWDL-60 (6.0 mm)	SWDL-62 (6.2 mm)	SWRR-2	DLCW-2003
V2365	15	6.5	0.256	SWDL-65 (6.5 mm)	SWDL-67 (6.7 mm)	SWRR-3	DLCW-3003
V2380	15	8	0.315	SWDL-80 (8.0 mm)	SWDL-82 (8.2 mm)	SWRR-3	DLCW-3003
V2425	20	2.5	0.098	SWDL-25 (2.5 mm)	SWDL-27 (2.7 mm)	SWRR-1	DLCW-1003
V2430	20	3	0.118	SWDL-30 (3.0 mm)	SWDL-32 (3.2 mm)	SWRR-1	DLCW-1003
V2435	20	3.5	0.138	SWDL-35 (3.5 mm)	SWDL-37 (3.7 mm)	SWRR-2	DLCW-2003
V2440	20	4	0.157	SWDL-40 (4.0 mm)	SWDL-42 (4.2 mm)	SWRR-2	DLCW-2003
V2445	20	4.5	0.177	SWDL-45 (4.5 mm)	SWDL-47 (4.7 mm)	SWRR-2	DLCW-2003
V2450	20	5	0.197	SWDL-50 (5.0 mm)	SWDL-52 (5.2 mm)	SWRR-2	DLCW-2003
V2455	20	5.5	0.217	SWDL-55 (5.5 mm)	SWDL-57 (5.7 mm)	SWRR-2	DLCW-2003
V2460	20	6	0.236	SWDL-60 (6.0 mm)	SWDL-62 (6.2 mm)	SWRR-2	DLCW-2003
V2465	20	6.5	0.256	SWDL-65 (6.5 mm)	SWDL-67 (6.7 mm)	SWRR-3	DLCW-3003

Captive Water Column Membranes (Includes O-Rings)

fits DLCW-1003	
Part Number	Qty./Desc.
DLCW-1003-MK25	25 Std.
DLCW-1003-MK50	50 Std.
DLCW-1003-MKX25	25 Hvy. Duty
DLCW-1003-MKX50	50 Hvy. Duty

fits DLCW-2003	
Part Number	Qty./Desc.
DLCW-2003-MK25	25 Std.
DLCW-2003-MK50	50 Std.
DLCW-2003-MKX25	25 Hvy. Duty
DLCW-2003-MKX50	50 Hvy. Duty

fits DLCW-3003	
Part Number	Qty./Desc.
DLCW-3003-MK25	25 Std.
DLCW-3003-MK50	50 Std.
DLCW-3003-MKX25	25 Hvy. Duty
DLCW-3003-MKX50	50 Hvy. Duty

High-Frequency Transducers

High-frequency transducers are single element contact or immersion transducers designed to produce frequencies of 20 MHz and greater.

Advantages

- Heavily damped broadband design provides excellent time resolution
- Short wavelengths for superior flaw resolution capabilities
- Focusing enables very small beam diameters
- Frequencies range from 20 MHz to 225 MHz

Applications

- High-resolution flaw detection such as inspection for microporosity or microcracks
- C-scan imaging of surface breaking cracks or irregularities
- Thickness measurements of materials as thin as 0.0004 in. (0.010 mm)*
- Examination of ceramics and advanced engineering materials
- Materials analysis

*Thickness range depends on material, transducer, surface condition, temperature, and setup selected.

High-Frequency Contact

- Permanent fused silica delay line enables flaw evaluation, material analysis, or thickness measurements using a direct contact testing method
- Three different delay line configurations (BA, BB, BC) enable various combinations of delay line echoes
- Standard connector style is Right Angle Microdot™ (RM)

Frequency MHz	Nominal Element Size		Delay	Transducer Part Numbers
	in.	mm	µs.	
20	0.25	6	4.25	V212-BA-RM
	0.25	6	4.25	V212-BB-RM
	0.25	6	2.5	V212-BC-RM
30	0.25	6	4.25	V213-BA-RM
	0.25	6	4.25	V213-BB-RM
	0.25	6	2.5	V213-BC-RM
50	0.25	6	4.25	V214-BA-RM
	0.25	6	4.25	V214-BB-RM
	0.25	6	2.5	V214-BC-RM
	0.125	3	4.25	V215-BA-RM
	0.125	3	4.25	V215-BB-RM
75	0.125	3	2.5	V215-BC-RM
	0.25	6	2.5	V2022 (BC)
	0.125	3	2.5	V2025 (BC)
100	0.125	3	4.25	V2054 (BA)
	0.125	3	2.5	V2012 (BC)
125	0.125	3	2.5	V2062

Please contact us for transducers in higher frequencies.

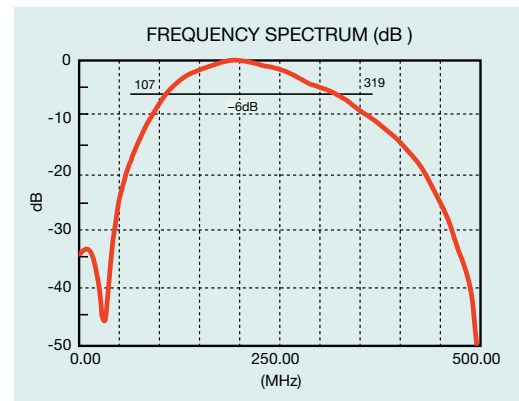
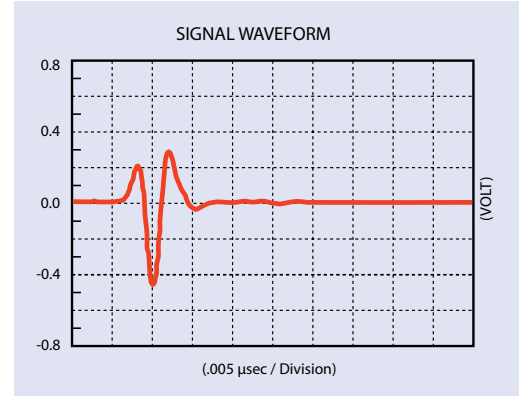

Contact transducers are available in frequencies up to 225 MHz and for immersion transducers up to 180 MHz. Performance is dependent on pulser/receiver and application. All transducers are manufactured on a special basis. Contact us to discuss applications.

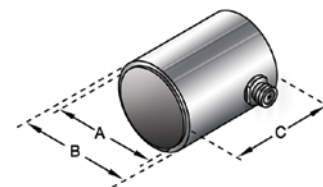

Transducer Dimensions
(in inches)

Delay Style	(A)	(B)	(C)
BA	0.72	0.81	1.00
BB	0.34	0.44	0.81
BC	0.34	0.44	0.63

High-Frequency Standard Immersion Case

- Permanent fused silica delay line
- Focused units use an optical quality ground lens
- F202 adaptor enables fixturing with a passive UHF connector and an active Microdot™ style connector (see "Couplants and Adaptors" on page 40)
- Combines high frequency with a small case design

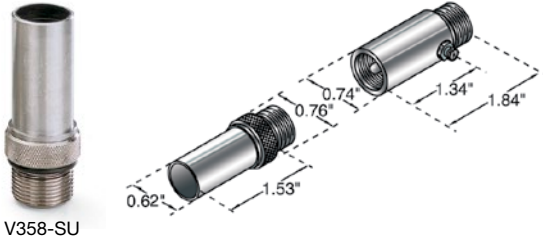

Frequency MHz	Nominal Element Size		Delay μs.	Focal Length		Transducer Part Numbers
	in.	mm		in.	mm	
20	0.25	6	4.25	flat		V354-SU
	0.25	6	2.25	0.75	19	V372-SU
	0.25	6	4.25	1.25	32	V373-SU
	0.25	6	4.25	2.00	51	V374-SU
30	0.25	6	4.25	flat		V356-SU
	0.25	6	2.25	0.75	19	V375-SU
	0.25	6	4.25	1.25	32	V376-SU
	0.25	6	4.25	2.00	51	V377-SU
50	0.25	6	4.25	flat		V358-SU

High-Frequency SU/RM Immersion Case

- Permanent fused silica delay with an optical quality ground lens provides a high degree of precision in beam alignment and focusing
- Stainless steel case has a passive Straight UHF (SU) connector and an active Right Angle Microdot™ (RM) connector
- Large cases enable larger delay lines and a decrease in delay reverberations and noise

Frequency MHz	Nominal Element Size		Delay μs.	Focal Length		Transducer Part Numbers
	in.	mm		in.	mm	
50	0.25	6	19.5	0.50	13	V390-SU/RM
	0.25	6	19.5	0.75	19	V3192
	0.25	6	19.5	1.00	25	V3193
	0.25	6	19.5	1.75	45	V3409
	0.25	6	19.5	2.00	51	V3337
	0.25	6	9.4	0.20	5	V3330*
75	0.125	3	19.5	0.50	13	V3332
	0.25	6	19.5	0.50	13	V3320
90	0.25	6	19.5	0.75	19	V3349
	0.25	6	19.5	0.50	13	V3512
100	0.25	6	19.5	0.50	13	V3194
	0.25	6	19.5	1.00	25	V3394
	0.25	6	9.4	0.20	5	V3534*
	0.125	3	10	0.25	6	V3346

Please contact us for higher frequency immersion probes up to 180 MHz

V3194 with F109 transformer

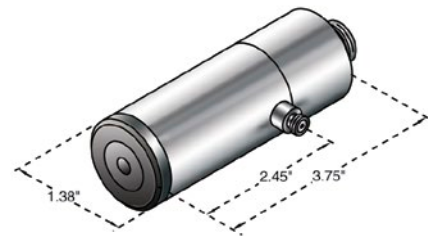

*Transducers create surface waves in steel, titanium, and other materials with similar velocities. Lightweight, high-frequency transducers are an alternative to the SU/RM case style transducers. They offer a smaller case width and lighter weight without sacrificing performance.

Dual Element Transducers for Thickness Gages

Olympus offers a complete line of dual element and single element transducers for use with its corrosion thickness gages. Most of these transducers feature automatic probe recognition for maximum gage performance for each transducer. These transducers are available in an assortment of frequencies, sizes, and temperature capabilities to provide an off-the-shelf solution to most corrosion applications. EN15317 certified dual element probes are issued TP106 test reports.



Gage Dual Transducers

Transducer Part Number	Frequency MHz	Tip Diameter		Connector Type	Connector Location	Range in Steel		Temperature Range		Wand	Holder (w/ wand)
		in.	mm			in.	mm	°F	°C		
D790	5.0	0.434	11	Potted	Straight	0.040 – 20	1.0 – 508	-5 to 932	-20 to 500	F152	F152A
D790-SM	5.0	0.434	11	Microdot	Straight	0.040 – 20	1.0 – 508	-5 to 932	-20 to 500	F152	F152A
D790-SL	5.0	0.434	11	LEMO 00	Straight	0.040 – 20	1.0 – 508	-5 to 932	-20 to 500	F152	F152A
D790-RL	5.0	0.434	11	LEMO 00	Rt Angle	0.040 – 20	1.0 – 508	-5 to 932	-20 to 500	—	—
D791	5.0	0.434	11	Potted	Rt Angle	0.040 – 20	1.0 – 508	-5 to 932	-20 to 500	—	—
D791-RM	5.0	0.434	11	Microdot	Rt Angle	0.040 – 20	1.0 – 508	-5 to 752	-20 to 400	—	—
D7912	10	0.295	7.5	Potted	Straight	0.020 – 1	0.5 – 25	32 to 122	0 to 50	—	—
D7913	10	0.295	7.5	Potted	Rt Angle	0.020 – 1	0.5 – 25	32 to 122	0 to 50	—	—
D794	5.0	0.283	7.2	Potted	Straight	0.030 – 2	0.75 – 50	32 to 122	0 to 50	F150	F150A
D797	2.0	0.900	22.9	Potted	Rt Angle	0.150 – 25	3.8 – 635	-5 to 752	-20 to 400	—	—
D797-SM	2.0	0.900	22.9	Microdot	Straight	0.150 – 25	3.8 – 635	-5 to 752	-20 to 400	—	—
D7226	7.5	0.350	8.9	Potted	Rt Angle	0.028 – 4	0.71 – 100	-5 to 300	-20 to 150	—	—
D798-LF	7.5	0.350	8.9	Potted	Rt Angle	0.028 – 4	0.71 – 100	-5 to 300	-20 to 150	—	—
D798	7.5	0.283	7.2	Potted	Rt Angle	0.028 – 4	0.71 – 100	-5 to 300	-20 to 150	—	—
D798-SM	7.5	0.283	7.2	Microdot	Straight	0.028 – 4	0.71 – 100	-5 to 300	-20 to 150	—	—
D799	5.0	0.434	11	Potted	Rt Angle	0.040 – 20	1.0 – 508	-5 to 300	-20 to 150	—	—
D7910	5.0	0.500	12.7	Potted	Rt Angle	0.040 – 10	1.0 – 254	32 to 122	0 to 50	—	—
MTD705*	5.0	0.200	5.1	Lepra/Con	Rt Angle	0.040 – 0.75	1.0 – 19	32 to 122	0 to 50	—	—

Gage Dual Cables

Cable Part Number	For Use With	Length		Cable Type	Plug Type
		feet	meters		
LCMD-316-5B	D790-SM	5.0	1.5	Standard	Straight
RLCMD-316-5B	D790-SM	5.0	1.5	Standard	Rt Angle
LCMD-178-5B SSA	D790-SM	5.0	1.5	Armored	Straight
RLCMD-178-5B SSA	D790-SM	5.0	1.5	Armored	Rt Angle
LCLD-316-5G	D790-RL	5.0	1.5	Standard	Straight
LCLD-316-5H	D790-SL	5.0	1.5	Standard	Straight
LCMD-316-5C	D791-RM	5.0	1.5	Standard	Straight
LCMD-316-5D	D797-SM	5.0	1.5	Standard	Straight
LCMD-316-5J	D798-SM	5.0	1.5	Standard	Straight
LCMD-316-5L	D7906-SM	5.0	1.5	Standard	Straight
LCMD-316-5N	D7906-RM	5.0	1.5	Standard	Straight
LCLPD-78-5	MTD705	5.0	1.5	Standard	Straight

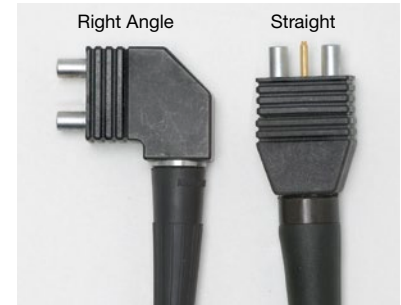

The above picture illustrates the RLCMD (Right Angle) and LCMD (Straight) probe recognition plugs that are compatible only with Olympus brand thickness gages. The probe recognition technology automatically notifies the gage of the frequency and probe type being used. No information needs to be entered by the inspector.

Other Thickness Gage Transducers

Transducer Part Number	Frequency	Tip or Element Diameter		Transducer Type	Connector Type	Connector Location	Range in Steel		Temperature Range		Holder
		in.	mm				in.	mm	°F	°C	
V260-SM	15	0.080	2	Sonopen®	Microdot™	Straight	0.02–0.400	0.5–10	32–122	0–50	SLH-V260-SM
D7906-SM*	5.0	0.434	11	THRU-COAT® Dual	Microdot	Straight	0.040–2.0	1.0–50	32–122	0–50	F152 / F152A
D7906-RM*	5.0	0.434	11	THRU-COAT Dual	Microdot	Right Angle	0.040–2.0	1.0–50	32–122	0–50	—
D7908*	7.5	0.283	7.2	THRU-COAT Dual	Potted	Right Angle	0.040–1.5	0.71–37	32–122	0–50	—
M2017	20	0.311	7.9	Internal Oxide Scale	Microdot	Right Angle	0.020–0.50 Oxide: 0.010–0.050	0.5–12 Oxide: 0.25–1.25	32–122	0–50	2127
M2091	20	0.311	7.9	Replaceable Delay Line Shear Wave	Microdot	Right Angle	0.020–0.50 Oxide: 0.006–0.050	0.5–12 Oxide: 0.150–1.25	32–122	0–50	2127
E110-SB†	—	1.13	28.7	EMAT	BNC	Straight	0.080–5	2.0–125	32–176	0–80	—

* THRU-COAT dual element transducers.

† Adaptor required for E110 (part number 1/2XA/E110).

Select probes and features require the purchase of gage software options.

Thickness range dependent on material, surface conditions, and temperature. Full range may require gain adjustment.

Electromagnetic Acoustic Transducer (EMAT)

The Olympus E110-SB electromagnetic acoustic transducer employs a magnetostrictive effect of external oxide scale to transmit and receive ultrasonic waves. This special EMAT probes does not require the removal of external scale or use of couplant, and works in contact or at a small distance from the surface*. The E110-SB probe may be used with the 38DL Plus thickness gage** and conventional UT flaw detectors.



M2008

This 500 kHz, 1 in. broadband, highly damped transducer is used to measure the thickness of fiberglass, composites, and other attenuating materials. The M2008 (U8415001) features a straight BNC connector and a replaceable delay line designed to couple well with low impedance materials.

Atlas® European Standard Transducers

Our Atlas European standard transducers are available in dual element, angle beam, contact, and protected face styles designed to meet inspection criteria referenced throughout Europe and the rest of the world. Our Atlas transducers are available in metric unit element diameters and common frequencies, such as 1, 2, 4, 5, and 6 MHz.



Dual Element Transducers

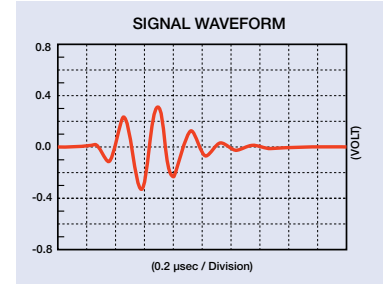
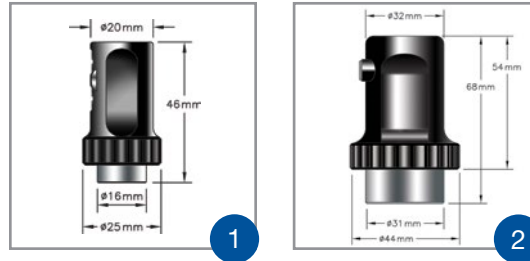

Frequency	Nominal Element Size	Transducer Part Number	Focus in Steel	Typical Bandwidth	Connector	Connector Location	Outline #
MHz	mm		mm	(%)			
2.0	7 × 18	DL2R-7X18	15	50	LEMO® 00 (2)	Right Angle	2
	7 × 18	DL2R-7X18-0	30	50	LEMO 00 (2)	Right Angle	2
	11	DL2R-11	8	48	LEMO 00 (2)	Right Angle	1
4.0	3.5 × 10	DL4R-3.5X10	10	45	LEMO 00 (2)	Right Angle	1
	6 × 20	DL4R-6X20	12	48	LEMO 00 (2)	Right Angle	2
	6 × 20	DL4R-6X20-0	25	48	LEMO 00 (2)	Right Angle	2

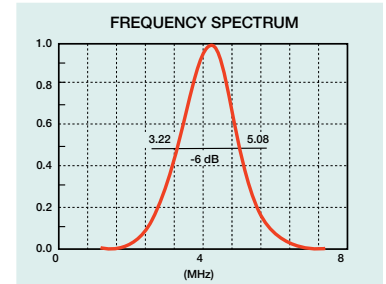

Signal waveform and frequency spectrum of DL4R-3.5X10

DGS diagrams are included with all Dual Element Transducers.

Contact Transducers

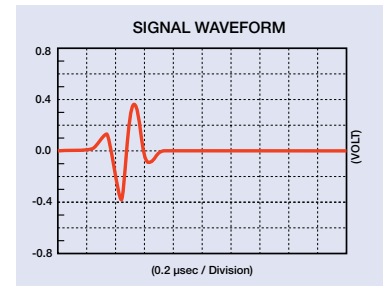
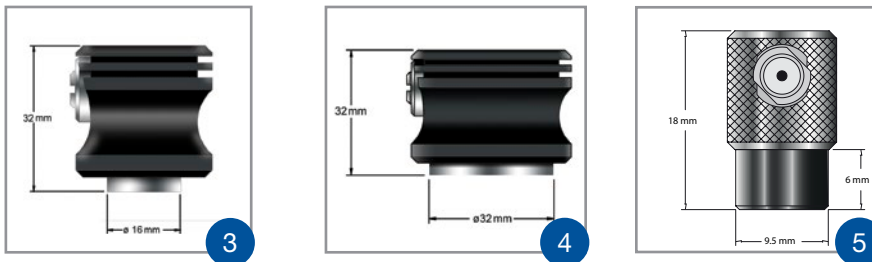

Frequency	Nominal Element Size	Transducer Part Number	Near Field	Typical Bandwidth	Connector	Connector Location	Outline #
MHz	mm		mm	(%)			
2.0	10	CN2R-10	7.2	85	LEMO 00	Right Angle	3
	24	CN2R-24	45	85	LEMO 00	Right Angle	4
4.0	10	CN4R-10	15.6	85	LEMO 00	Right Angle	3
	24	CN4R-24	91	85	LEMO 00	Right Angle	4
5.0	5	CN5R-5	127	60	Microdot	Right Angle	5
10	5	CN10R-5	254	60	Microdot	Right Angle	5

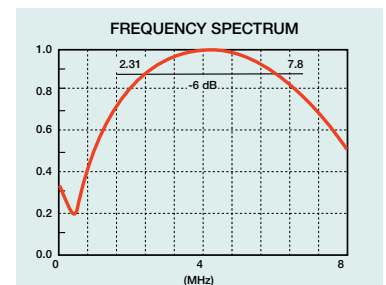

Signal waveform and frequency spectrum of CN4R-10

DGS diagrams are not available for Contact Transducers.

Integral Angle Beam Transducers

AM4R-8X9-70



AM 2R-8X9-45

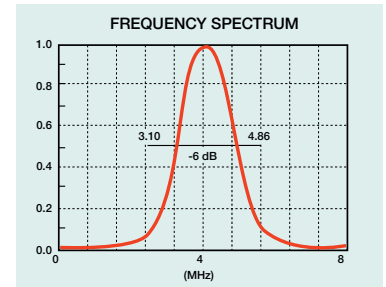
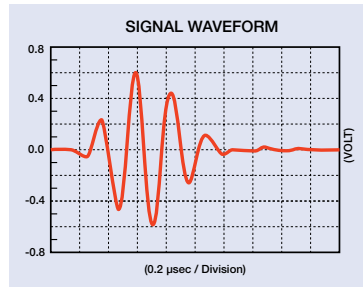

Signal waveform and frequency spectrum of AM4R-8X9-45

Frequency	Nominal Element Size	Angle	Near Field in Steel	Transducer Part Number	Typical Bandwidth	Connector	Connector Location	Outline #
MHz	mm	(°)	mm		(%)			
1.0	20 × 22	45	45	AM1R-20X22-45	55	LEMO® 1	Right Angle	9
	20 × 22	60	45	AM1R-20X22-60	55	LEMO 1	Right Angle	9
	20 × 22	70	45	AM1R-20X22-70	55	LEMO 1	Right Angle	9
2.0	8 × 9	45	15	AM2R-8X9-45	40	LEMO 00	Right Angle	6
	8 × 9	45	15	AM2S-8X9-45	40	LEMO 00	Straight	7
	8 × 9	60	15	AM2R-8X9-60	40	LEMO 00	Right Angle	6
	8 × 9	60	15	AM2S-8X9-60	40	LEMO 00	Straight	7
	8 × 9	70	15	AM2R-8X9-70	40	LEMO 00	Right Angle	6
	8 × 9	70	15	AM2S-8X9-70	40	LEMO 00	Straight	7
2.0	14 × 14	45	39	AM2R-14X14-45	45	LEMO 00	Right Angle	8
	14 × 14	60	39	AM2R-14X14-60	45	LEMO 00	Right Angle	8
	14 × 14	70	39	AM2R-14X14-70	45	LEMO 00	Right Angle	8
	20 × 22	38	90	AM2R-20X22-38	40	LEMO 1	Right Angle	9
	20 × 22	45	90	AM2R-20X22-45	40	LEMO 1	Right Angle	9
	20 × 22	60	90	AM2R-20X22-60	40	LEMO 1	Right Angle	9
	20 × 22	70	90	AM2R-20X22-70	40	LEMO 1	Right Angle	9
4.0	8 × 9	38	30	AM4R-8X9-38	40	LEMO 00	Right Angle	6
	8 × 9	45	30	AM4R-8X9-45	40	LEMO 00	Right Angle	6
	8 × 9	45	30	AM4S-8X9-45	40	LEMO 00	Straight	7
	8 × 9	60	30	AM4R-8X9-60	40	LEMO 00	Right Angle	6
	8 × 9	60	30	AM4S-8X9-60	40	LEMO 00	Straight	7
	8 × 9	70	30	AM4R-8X9-70	40	LEMO 00	Right Angle	6
	8 × 9	70	30	AM4S-8X9-70	40	LEMO 00	Straight	7
	20 × 22	45	180	AM4R-20X22-45	40	LEMO 1	Right Angle	9
	20 × 22	60	180	AM4R-20X22-60	40	LEMO 1	Right Angle	9
20 × 22	70	180	AM4R-20X22-70	40	LEMO 1	Right Angle	9	
5.0	14 × 14	45	88	AM5R-14X14-45	40	LEMO 00	Right Angle	7
	14 × 14	60	88	AM5R-14X14-60	40	LEMO 00	Right Angle	7
	14 × 14	70	88	AM5R-14X14-70	40	LEMO 00	Right Angle	7
6.0	3 × 4	45	N/A	AM6S-3X4-45*	38	Microdot™	Straight	10
	3 × 4	60	N/A	AM6S-3X4-60*	38	Microdot	Straight	10
	3 × 4	70	N/A	AM6S-3X4-70*	38	Microdot	Straight	10

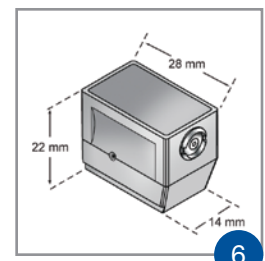

6

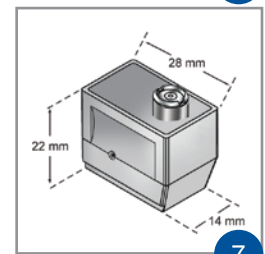

7

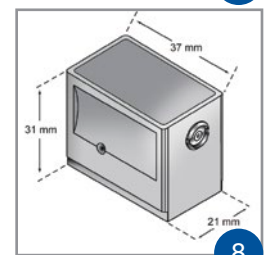

8

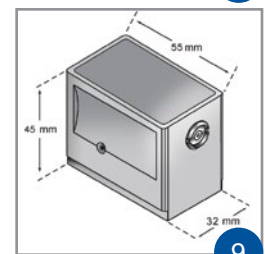

9

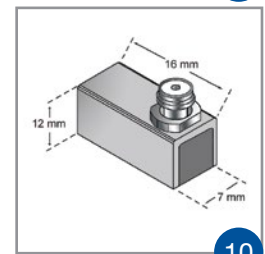

10

Optional wear shoes can be purchased for the 8 × 9, 14 × 14, and 20 × 22 integral angle beam probes in packs of 10; AM-8X9-SHOE, AM-14x14-SHOE, and AM-20x22-SHOE.

* DGS diagrams are included with all Integral Angle Beam Transducers except AM6S-3x4-45 and AM6S-3x4-60.

Integral Angle Beam with Composite Elements

Frequency	Nominal Element Size	Angle	Transducer Part Number	Near Field	Typical Bandwidth	Connector	Connector Location	Outline #
MHz	mm			mm	(%)			
2.0	8 × 9	45°	AM2R-8X9-C45	15	65	LEMO® 00	Right Angle	6
	8 × 9	60°	AM2R-8X9-C60	15	65	LEMO 00	Right Angle	6
	8 × 9	70°	AM2R-8X9-C70	15	65	LEMO 00	Right Angle	6
4.0	8 × 9	45°	AM4R-8X9-C45	30	80	LEMO 00	Right Angle	6
	8 × 9	60°	AM4R-8X9-C60	30	80	LEMO 00	Right Angle	6
	8 × 9	70°	AM4R-8X9-C70	30	80	LEMO 00	Right Angle	6

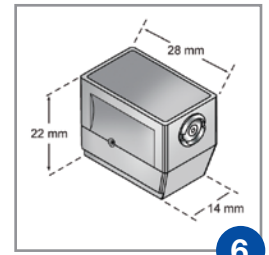

Protected Face Transducers

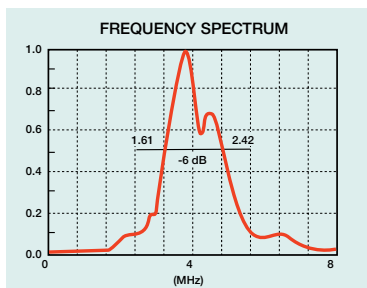
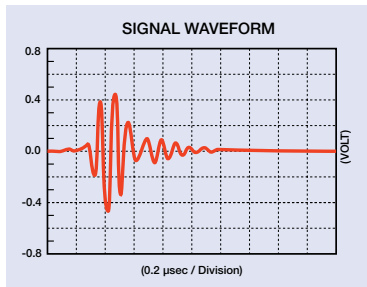
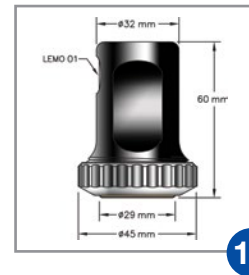

Signal waveform and frequency spectrum of PF2R-24

Frequency	Nominal Element Size	Transducer Part Number	Near Field	Typical Bandwidth	Connector	Connector Location	Outline #
MHz	mm		mm	(%)			
1.0	24	PF1R-24	23	45	LEMO 1	Right Angle	12
	24	PF1S-24	23	45	LEMO 1	Straight	11
2.0	10	PF2R-10	7.2	45	LEMO 00	Right Angle	13
	24	PF2R-24	45	45	LEMO 1	Right Angle	12
4.0	24	PF2S-24	45	45	LEMO 1	Straight	11
	10	PF4R-10	15.6	35	LEMO 00	Right Angle	13
	24	PF4R-24	91	30	LEMO 1	Right Angle	12
	24	PF4S-24	91	30	LEMO 1	Straight	11

DGS diagrams are included with all Protected Face Transducers.

Protective Membrane Accessories

Description	Fits With Nominal Element Size	Part Number
	mm	
Set of 12 Membranes	10	PM-10-12
Set of 12 Membranes	24	PM-24-12
Retaining Ring	10	MRN-10
Retaining Ring	24	MRN-24

Protective membranes for Atlas® probes are not interchangeable with those used on standard protected face transducers



TOFD Transducers

Our time-of-flight diffraction (TOFD) transducers are highly damped longitudinal wave probes that offer excellent resolution in challenging TOFD applications. These highly sensitive composite element broadband transducers are available in frequencies from 2.25 MHz to 15 MHz and in sizes from 3 mm (0.25 in.) to 12 mm (0.50 in.). They are for use with specialized TOFD wedges designed to produce refracted longitudinal waves in steel.

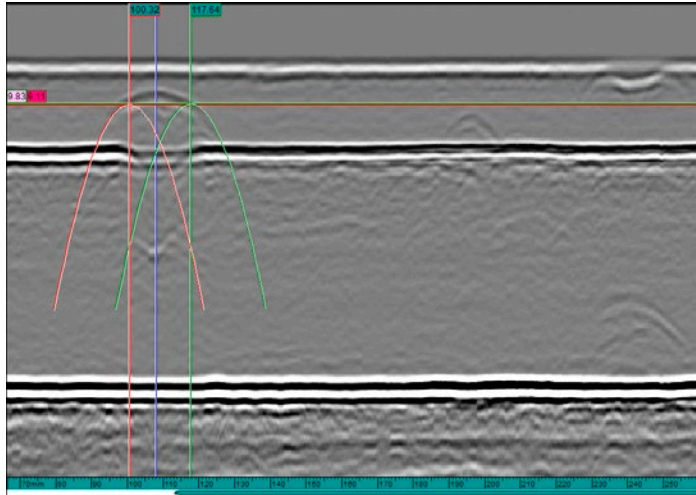

TOFD scan screen shot generated with Olympus OmniPC™ software.

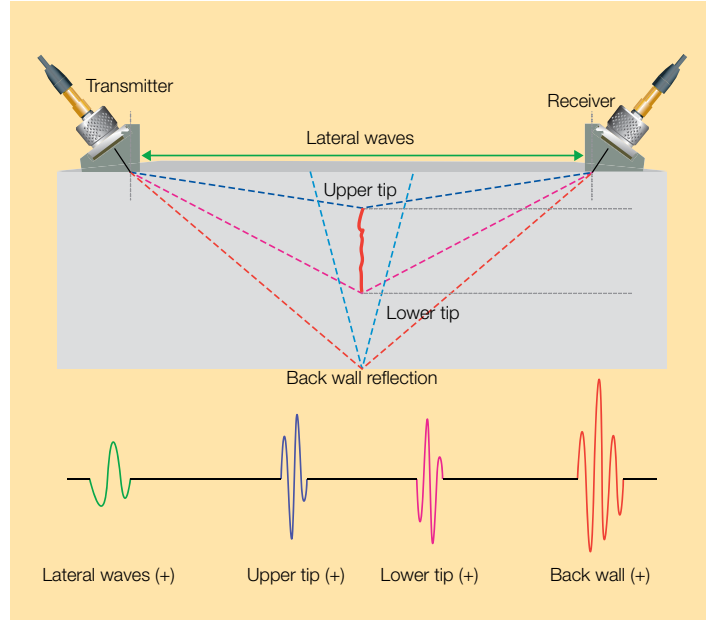

Miniature Screw-In TOFD Transducers

Frequency MHz	Nominal Element Size		Transducer Part Numbers	Wedge Type
	in.	mm		
2.25	0.25	6	C542	ST1
	0.375	9.5	C566	ST2
	0.5	12	C540	ST2
5.0	0.125	3	C567	ST1 **
	0.25	6	C543	ST1
	0.375	9.5	C568	ST2
	0.5	12	C541	ST2
10	0.125	3	C563	ST1 **
	0.25	6	C544	ST1
15	0.125	3	V564*	ST1 **

* Active element is standard piezo-ceramic (not available in composite).

** 0.125 in. (3 mm) element size transducers are also compatible with ST1-XXX-Cobra wedges.

The probes in this table can be configured with Straight LEMO 00 (-SL) or Straight Microdot(-SM) connectors.

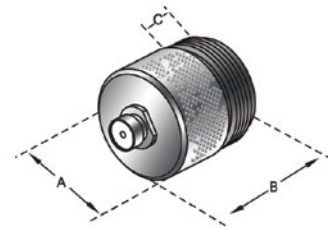

Transducer Dimensions (in inches)				
Nominal Element Size	(A)	(B)	(C)	Thread Pitch
0.125 0.25	0.44	0.55	0.22	3/8 - 32
0.375 0.5	0.71	0.685	0.257	1 1/16 - 24

TOFD Wedges Ordering Number Nomenclature

ST 1 - 45 L - IHC - A OD 8

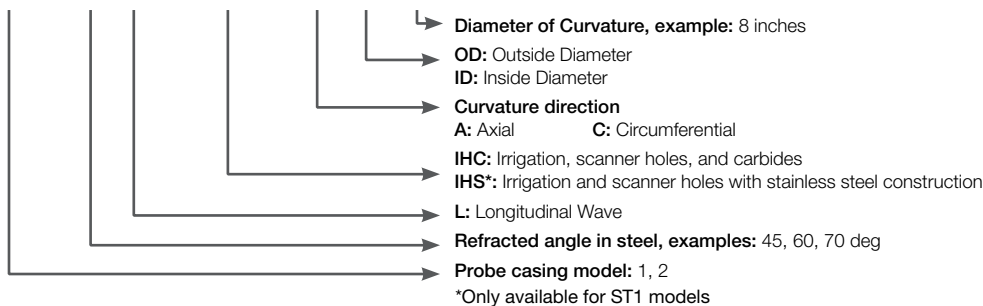

Test Blocks

Calibration and/or reference blocks should be used in every application. Standard blocks are available for angle beam calibrations and thickness calibrations of common materials.

- Blocks manufactured from 1018 steel, 304 stainless steel, or 7075-T6 aluminum are commonly in stock (other materials require special quotes for price and delivery)
- Contact us for more information regarding materials not listed, blocks not listed, or custom blocks

Calibration Blocks

All blocks are checked dimensionally using measuring equipment traceable to the National Institute of Standards and Technology, NIST. The most commonly required calibration blocks are listed below.

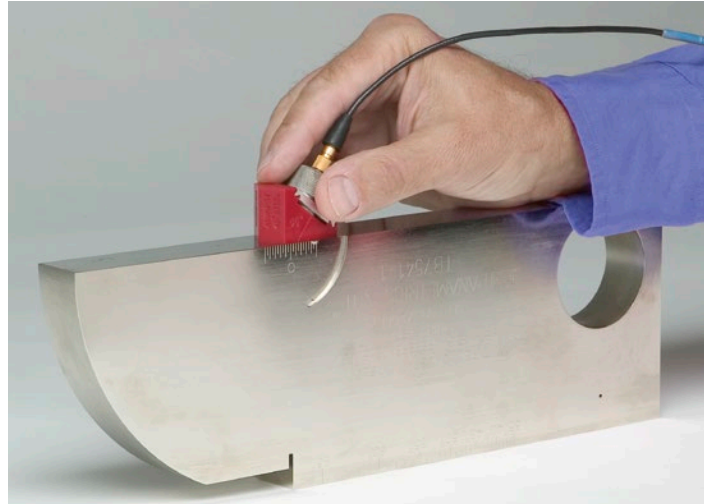

Type	Part Number	Description	Hardwood Case
ASTM E164 Calibration IIW-Type Block	TB7541-X	Meets AASHTO and AWS Type 1 block requirements. Calibrates distance and sensitivity settings. Measure refracted angle and sound exit point of angle beam transducers. U.S. customary units (inches).	F129
	TB1136-X	Meets AASHTO and AWS Type 1 block requirements. Calibrates distance and sensitivity settings. Measure refracted angle and sound exit point of angle beam transducers. U.S. customary units (inches). Block with Lucite plug.	F129
	TB1054-X	Metric units.	F129
	TB1137-X	Metric units. Block with Lucite plug.	F129
US Air Force IIW-2 Calibration Block	TB5939-X	IIW-type block per U.S. Air Force NDI Manual T.O. 33B -1-1. Includes 2 in. and 4 in. radius cutouts for distance calibration. No. 3, No. 5, and No. 8 side-drilled holes and distance calibration marks to the 2 in. hole.	F129
RC AWS Block	TB7543-X	Determining resolution capabilities of angle beam transducers per AWS and AASHTO requirements.	F157
SC AWS Block	TB7545-X	Sensitivity and refracted angle calibration per AWS and AASHTO requirements.	F158
DC AWS Block	TB7547-X	Distance and beam index calibration for angle beam transducers per AWS and AASHTO requirements.	F159
DSC AWS Block	TB7549-X	Distance, sensitivity, refracted angle and beam index calibration for angle beam transducers per AWS and AASHTO requirements.	F160
DS AWS Block	TB7551-X	Calibration block for horizontal linearity and dB accuracy procedures per AWS and AASHTO requirements.	F161
30FBH Resolution Reference Block	TB7160-X	Evaluate near-surface resolution and flaw size/depth sensitivity of UT equipment. No. 3, No. 5, and No. 8 ASTM flat-bottom holes at ten metal travel distances from 0.050 in. to 1.250 in.	Included
NAVSHIPS Block	TB7567-X	Contains six No. 3-side drilled holes. Used for distance-amplitude calibration per NAVSHIPS 0900-006 -3010.	F162
ASTM E164 MAB Block	TB7150-X	Miniature Angle Beam (ROMPAS) block. Distance, beam index, refracted angle, and sensitivity calibration. One inch thick.	F197
ISO 7963 Steel	TB1065-X	Miniature Angle Beam block distance, beam index, refracted angle, and sensitivity calibration. 25 mm thick.	F197

Replace the "X" in the part number with the appropriate number listed below to signify block material:

- 1 = 1018 Steel
- 2 = 4340 Steel
- 4 = 7075-T6 Aluminum
- 5 = 304 Stainless Steel
- 8 = 6-4 Titanium

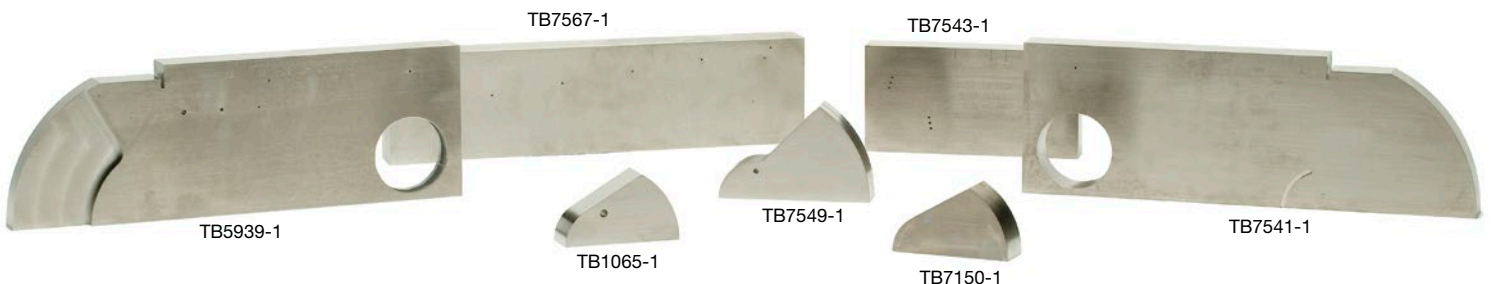

Reference Blocks

We offer commonly used sets of reference blocks recommended by ASTM standards. These sets are manufactured to ASTM E127 and ASTM E428 physical dimensions requirements. All reference blocks are provided with an ultrasonic response curve. We can provide, by special order, materials not listed and individual reference blocks. Contact us for more information regarding materials not listed, custom calibration blocks, or quotations on blocks not listed in this section.



Type of Set*	Part Number	Description of Set
Distance-Area Amplitude Set	TB6100-X	Set of 10 ASTM E 127 (7075 Alum) or ASTM E 428 (all other materials) basic set consisting of $\frac{3}{64}$ at 3 in., $\frac{5}{64}$ at $\frac{1}{8}$ in., $\frac{1}{4}$ in., $\frac{1}{2}$ in., $\frac{3}{4}$ in., 1- $\frac{1}{2}$ in., 3 in., and 6 in., and $\frac{3}{64}$ at 3 in. and 6 in. This set is used for determining dead zone, sensitivity, distance, and area amplitude linearity measurement.
Area-Amplitude Set	TB6200-X	Set of 8 ASTM E 127 (7075 Alum) or ASTM E 428 (all other materials) Area Amplitude Set consisting of $\frac{1}{64}$, $\frac{2}{64}$, $\frac{3}{64}$, $\frac{4}{64}$, $\frac{5}{64}$, $\frac{6}{64}$, $\frac{7}{64}$, and $\frac{8}{64}$ flat-bottom holes at 3 in. This set is used to determine the relationship between flaw size and echo amplitude by comparing signal response.
Distance-Amplitude Set-No. 3FBH	TB6303-X	Set of 19 ASTM E 127 (7075 Alum) or ASTM E 428 (all other materials) Distance Amplitude Set. All flat-bottom holes are the same and metal travel distances are $\frac{1}{16}$ in., $\frac{1}{8}$ in., $\frac{1}{4}$ in., $\frac{3}{16}$ in., $\frac{1}{2}$ in., $\frac{5}{8}$ in., $\frac{3}{4}$ in., $\frac{7}{8}$ in., 1 in., 1- $\frac{1}{4}$ in., 1- $\frac{3}{4}$ in., 2- $\frac{1}{4}$ in., 2- $\frac{3}{4}$ in., 3- $\frac{1}{4}$ in., 3- $\frac{3}{4}$ in., 4 in., 4- $\frac{3}{4}$ in., 5- $\frac{1}{4}$ in., and 5- $\frac{3}{4}$ in. This set is used to determine the relationship between metal distance and signal amplitude by comparing signal responses obtained.
Set-No. 5FBH	TB6305-X	
Set-No. 8FBH	TB6308-X	
Sensitivity-Resolution Set	TB6025-X	Set of 9 ASTM E 127 (7075 Alum) or ASTM E 428 (all other materials) consisting of $\frac{1}{64}$ at 3 in., $\frac{2}{64}$ at 3 in., and $\frac{5}{64}$ at $\frac{1}{8}$ in., $\frac{1}{4}$ in., $\frac{3}{8}$ in., $\frac{1}{2}$ in., $\frac{3}{4}$ in., 1 in., and 1- $\frac{1}{2}$ in., and 1 ASTM E 317 horizontal and vertical linearity block used to evaluate the sensitivity, entry surface resolution, and horizontal and vertical linearity characteristics of UT equipment.

Replace the "X" in the part number with the appropriate number listed below to signify block material:

- 1 = 1018 Steel
- 2 = 4340 Steel
- 4 = 7075-T6 Aluminum
- 5 = 304 Stainless Steel
- 8 = 6-4 Titanium
- *Includes Hardwood case

Thickness Calibration Blocks

- Blocks are held to tighter tolerances than called out in the ASTM E797 Code.

Material	Part Numbers	Steps
304 Stainless Steel	2211E	0.100 in., 0.200 in., 0.300 in., 0.400 in., 0.500 in.
304 Stainless Steel	2211M	2.5 mm, 5.0 mm, 7.5 mm, 10.0 mm, 12.5 mm
1018 Carbon Steel	2212E	0.250 in., 0.500 in., 0.750 in., 1.00 in.
1018 Carbon Steel	2212M	6.25 mm, 12.5 mm, 18.75 mm, 25 mm
7075-T6 Aluminum	2213E	0.100 in., 0.200 in., 0.300 in., 0.400 in., 0.500 in.
7075-T6 Aluminum	2213M	2.5 mm, 5.0 mm, 7.5 mm, 10.0 mm, 12.5 mm
1018 Carbon Steel	2214E	0.100 in., 0.200 in., 0.300 in., 0.400 in., 0.500 in.
1018 Carbon Steel	2214M	2.5 mm, 5.0 mm, 7.5 mm, 10.0 mm, 12.5 mm

Note: For hardwood case, order 2214C.

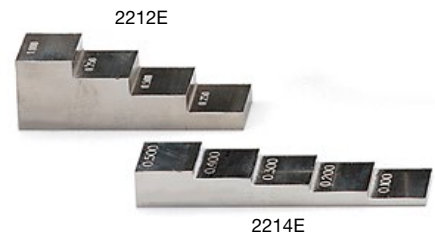

Cables

- Select from a variety of cable grades to meet your specific application needs
- Standard lengths: 3 ft (1 m), 4 ft (1.2 m), 6 ft (1.8 m); when ordering, replace the x in the part number with the desired cable length in feet
- Custom cable lengths are available depending on configuration and quantity; please specify when ordering
- Part numbering prefix indicates connector style for both ends of the cable
- All cables are 50 ohms impedance unless otherwise specified
- Contact us for special or customized cables



Standard

Cable Part Numbers	Fits Connector Style
BCB-58-X BCB-74-X BCM-74-X BCMA-74-X BCRM-74-X BCU-58-X BCU-62-X	Fits BNC to BNC Fits BNC to BNC Fits BNC & Microdot™ Fits BNC & Microdot without Boot Fits BNC & Right Angle Microdot Fits BNC to UHF Fits BNC to UHF (93 ohms)
FLCB-74-X LCB-74-X LCM-74-X LCU-74-X L1CB-58-X L1CM-74-X L1CU-74-X L1CU-74-X	Fits Female LEMO® & BNC Fits Small LEMO 00 & BNC Fits Small LEMO 00 & Microdot Fits Small LEMO 00 & UHF Fits Large LEMO 1 & BNC Fits Large LEMO 1 & Microdot Fits Large LEMO 1 & UHF Fits Large LEMO 1 & UHF
UCM-74-X UCU-58-X	Fits UHF and Microdot Fits UHF to UHF

Heavy Duty (HD)

- External Teflon™ coating provides flexibility and improved cable performance in industrial settings

Cable Part Numbers	Fits Connector Style
BCB-188-X HD BCM-188-X HD BCU-188-X HD	Fits BNC to BNC Fits BNC and Microdot Fits BNC to UHF
LCB-188-X HD LCM-188-X HD	Fits Small LEMO 00 and BNC Fits Small LEMO 00 and Microdot

Waterproof (W)

- Specially designed proprietary waterproof UHF connector provides a waterproof connection good to depths of about 150 ft (50 m) in fresh water

Cable Part Numbers	Fits Connector Style
BCM-74-X W BCRM-74-X W BCU-58-X W BCU-62-X W BCU-74-X W	Fits BNC to Water-Resistant Microdot Fits BNC to Water-Resistant Right Angle Microdot Fits BNC to Waterproof UHF Fits BNC to Waterproof UHF (93 ohms) Fits BNC to Waterproof UHF
LCM-74-X W LCU-74-X W L1CU-74-X W	Fits Small LEMO 00 to Water-Resistant Microdot Fits Small LEMO 00 to Waterproof UHF Fits Large LEMO 1 to Waterproof UHF

For Large LEMO cables, a LEMO 1S.275 connector is typically used

Armored Stainless Steel (SSA)

Interlocking stainless steel jacket provides flexibility, protection, and ruggedness in industrial settings.

- Can be ordered in lengths up to 20 ft (6.1 m)

Cable Part Numbers	Fits Connector Style
BCB-188-X SSA BCM-188-X SSA BCRM-188-X SSA	Fits BNC to BNC Fits BNC and Microdot Fits BNC and Right Angle Microdot
LCM-188-X SSA LCRM-188-X SSA	Fits Small LEMO 00 and Microdot Fits Small LEMO 00 and Right Angle Microdot

Double Shielded (DS)

- Additional grounded shield provides low cable noise for better performance in high-frequency applications
- 15 ohm or 25 ohm cables of different lengths may help to optimize high-frequency system performance

Cable Part Numbers	Fits Connector Style	Impedance
BCM-74-X DS	Fits BNC and Microdot	50 ohms
BCM-15-X DS	Fits BNC and Microdot	15 ohms
BCM-25-X DS	Fits BNC and Microdot	25 ohms

Cables with Handle

- Special 3 in. (75 mm) long reinforced handle for increased durability and easier grip
- Custom handles can be ordered: 6 in. (152 mm) and 9 in. (229 mm)

Cable Part Numbers	Fits Connector Style	Handle Length
		inches
BCMH-74-X	Fits BNC and Microdot	3
LCMH-74-X	Fits Small LEMO 00 and Microdot	3
L1CMH-74-X	Fits Large LEMO 1 and Microdot	3
BCMH6-74-X	Fits BNC and Microdot	6
LCMH6-74-X	Fits Small LEMO 00 and Microdot	6
L1CMH6-74-X	Fits Large LEMO 1 and Microdot	6
BCMH9-74-X	Fits BNC and Microdot	9
LCMH9-74-X	Fits Small LEMO 00 and Microdot	9
L1CMH9-74-X	Fits Large LEMO 1 and Microdot	9

Standard



Standard RG174 Microdot™ Connector



Standard RG174 Right Angle Microdot Connector



Standard RG58 LEMO 1 Connector



Double Shielded RG58 (DS) Waterproof UHF Connector

Heavy Duty



RG188 Heavy Duty Teflon™ Coated (HD) Microdot Connector



RG188 Heavy Duty Teflon Coated (HD) Microdot Handle 3 in. Connector



RG188 Heavy Duty Teflon Coated (HD) BNC Connector



RG188 Heavy Duty Teflon Coated (HD) LEMO 00 Connector

Armored



RG188 Heavy Duty Armored PVC (HDAP) LEMO® 00 Connector



RG188 Heavy Duty Armored Super Flexible Silicone (HDAS) Microdot Connector



RG188 Armored Stainless Steel (SSA) Microdot Connector

Dual

- Single cable design with two connectors at each end to fit dual element transducers

Cable Part Numbers	Fits Connector Style	Compatible With
BCMD-74-6 LCMD-74-6 L1CMD-74-6	Dual BNC to Microdot Dual Small LEMO 00 to Microdot Dual Large LEMO 1 to Microdot	Standard Dual Transducer
BCMD-316-5F L1CMD-316-5F	Dual BNC to Microdot Dual Large LEMO 1 to Microdot	Flush Case Dual Transducer
BCLPD-78-5 L1CLPD-78-5	Dual BNC to Leptra/Con Dual Large LEMO 1 to Leptra/Con	MTD-705 Transducer

Heavy Duty, Armored, PVC (HDAP)

- Spiral stainless steel jacket with external solid PVC coating makes this cable very durable

Cable Part Numbers	Fits Connector Style
BCB-188-X HDAP BCM-188-X HDAP	Fits BNC to BNC Fits BNC to Microdot
LCB-188-X HDAP LCM-188-X HDAP	Fits Small LEMO 00 to BNC Fits Small LEMO 00 to Microdot

Heavy Duty, Armored Super Flexible Silicone (HDAS)

- Stainless steel jacket with an external silicone coating makes this cable durable, yet flexible

Cable Part Numbers	Fits Connector Style
BCB-188-X HDAS BCM-188-X HDAS	Fits BNC to BNC Fits BNC to Microdot
LCB-188-X HDAS LCM-188-X HDAS	Fits Small LEMO 00 to BNC Fits Small LEMO 00 to Microdot

Atlas

Cable Part Numbers	Fits Connector Style	Transducer Type	Length meters
L1CLD-316-2MK*	LEMO 00 × 2 to LEMO 1 × 2	Dual	2
LCLD-316-2MK*	LEMO 00 × 2 to LEMO 00 × 2	Dual	2
BCLD-316-2MK*	BNC × 2 to LEMO 00 × 2	Dual	2
LCL-74-2M	LEMO 00 to LEMO 00	Single	2
L1CL1-74-2M	LEMO 1 to LEMO 1	Single	2
L1CL-74-2M	LEMO 1 to LEMO 00	Single	2
LCB-74-2M	LEMO 00 to BNC	Single	2

*Dual cables can be used only with "Atlas Dual Element Transducers" on page 32

Couplants and Adaptors

Couplants

The use of couplant is almost always necessary to provide acoustic coupling between the transducer and the test piece. We offer various types of couplants to suit virtually all applications.

Part Number	Description	Volume	Application
B2	Glycerin	2 oz. (0.06 liter)	General purpose, more viscous, and has a high acoustic impedance making it the preferred couplant for rough surfaces and highly attenuating materials.
D12	Gel Type	12 oz. (0.35 liter)	Rough surfaces such as sand-cast metals and fiberglass layups, weld inspections, overhead surfaces, or vertical walls.
H-2	High Temp	2 oz. (0.06 liter)	Temperature range 0 °F to 750 °F (-18 °C to 400 °C) in many open environment applications when used per manufacturer's recommended procedure.*
I-2	High Temp	2 oz. (0.06 liter)	Temperature range -40 °F to 1250 °F (-40 °C to 675 °C); for more details please reference the SDS.*
SWC-2	Shear Wave	2 oz. (0.06 liter)	Normal incidence shear wave, non-toxic, water soluble organic substance of very high viscosity.

*Typical UT flaw and thickness applications use thin couplant films in an open environment where the small amount of gas formed can dissipate quickly. However, if an unlikely couplant gas auto ignition flash is of major concern, this couplant should not be used above the auto ignition temperature provided on the SDS.

Adaptors

Part Numbers	Fits Connector Style
F108	Right Angle UHF Male to UHF Female, waterproof
F195	45° UHF Female to UHF Male
F202	Active UHF Female to Passive UHF Male/Active Right Angle Microdot Female
F267	Right Angle UHF Female to UHF Male, waterproof
BF-BF	BNC Female to BNC Female
BM-BM	BNC Male to BNC Male
BM-UF	BNC Male to UHF Female
L1M-BF	LEMO® 1 Male to BNC Female
L1F-BM	LEMO 1 Female to BNC Male
L1F-LF	LEMO 1 Male to LEMO 00 Female
LF-BF	LEMO 00 Female to BNC Female
LF-LF	LEMO 00 Female to LEMO 00 Female
LM-BF	LEMO 00 Male to BNC Female
LF-BM	LEMO 00 Female to BNC Male
LF-UM	LEMO 00 Female to UHF Male
MM-UFW	Microdot™ Male to UHF Female, waterproof
MM-UMW	Microdot Male to UHF Male, waterproof
UM-BF	UHF Male to BNC Female



OLYMPUS SCIENTIFIC SOLUTIONS AMERICAS CORP.
is certified to **ISO 9001, ISO 14001, and OHSAS 18001.**

All specifications are subject to change without notice.
All brands are trademarks or registered trademarks of their respective owners and third party entities. Olympus, Centrascan, Videoscanner, Sonopen, THRU-COAT, 38DL PLUS, and Atlas are registered trademarks, and OmniPC is a trademark of Olympus Corporation. Microdot™ is a trademark of Tyco Electronics Corporation. LEMO is a registered trademark of LEMO SA. Copyright © 2019 by Olympus.

www.olympus-ims.com

OLYMPUS

OLYMPUS CORPORATION OF THE AMERICAS

48 Woerd Avenue, Waltham, MA 02453, USA, Tel.: (1) 781-419-3900
110 Magellan Circle, Webster TX, 77598, USA, Tel.: (1) 281-922-9300

OLYMPUS NDT CANADA INC.

505, boul. du Parc-Technologique, Québec (Québec) G1P 4S9, Tel.: (1) 418-872-1155
1109 78 Ave, Edmonton (Alberta) T6P 1L8

For inquiries - contact
www.olympus-ims.com/contact-us