

INSTRUCTIONS

COMPENSATORS

This instruction manual is for the Our Compensators. As this manual pertains only to the compensators, also refer to the instruction manual for your polarizing microscope so that you understand the operating procedures of the entire system.

To ensure the safety, obtain optimum performance and familiarize yourself fully with the use of these units, we recommend that you study this manual thoroughly before using them.

Optical Microscope Accessory



A X 5 8 9 4

IMPORTANT

These units employ a UIS2/UIS (Universal Infinity System) optical design, and should be used only with a microscope, eyepieces, objectives and condenser matching the UIS/UIS2 optics. Less than optimum performance may result if inappropriate accessories are used.

1 Getting Ready

1. A compensator is a precision instrument. Handle it with care and avoid subjecting it to sudden or severe impact.
2. Do not use the compensator where it is subjected to direct sunlight, high temperature and humidity, dust or vibrations.
(Working environment ambient temperature and humidity should be in the range of 0-40 °C and 30-90 %, respectively. Temperature at storage location should never be allowed to get below -10 °C).

2 Care and Storage

1. To clean the lenses and other glass components, simply blow dirty away using a commercially available blower and wipe gently using a piece of cleaning paper (or clean gauze). If a lens is stained with fingerprints or oil smudges, wipe it gauze slightly moistened with commercially available absolute alcohol.

- ⚠ Since the absolute alcohol is highly flammable, it must be handled carefully. Be sure to keep it away from open flames or potential sources of electrical sparks --- for example, electrical equipment that is being switched on or off. Also remember to always use it only in a well-ventilated room.**
2. Do not disassemble any part of the compensator.

3 Caution

If the equipment is used in a manner not specified by this manual, the safety of the user may be imperiled. In addition, the equipment may also be damaged. Always use the equipment as outlined in this instruction manual.

CONTENTS

1	OUTLINE	1
2	NOMENCLATURE	2
3	ASSEMBLY	5
4	PREPARATION AND MEASUREMENT	7
	4-1 Berek Compensator (U-CBE),	7
	Thick Berek Compensator (U-CTB).....	7
	4-2 Brace-Köhler Compensator (U-CBR1, U-CBR2).....	11
	4-3 Quarts Wedge (U-CWE2).....	14
	4-4 Senarmont Compensator (U-CSE).....	16

1 OUTLINE

Compensators are used for measuring the retardation in specimens with double refraction. Some compensators* may also be used to enhance image contrast in polarized light observation. The following table shows the retardation measuring range of the various compensators.

Measuring Range of Compensators

Compensator Name	Measuring Range
Thick Berek (U-CTB)	0 – 20 λ
Berek (U-CBE)	0 – 3 λ
Quartz Wedge (U-CWE2)	1 – 4 λ
* Senarmont Compensator (U-CSE)	0 – 1 λ
* Brace-Köhler Compensator 1/10 λ (U-CBR1)	0 – 1/10 λ
* Brace-Köhler Compensator 1/30 λ (U-CBR2)	0 – 1/30 λ

λ = 546.1 nm (e-line)

2 NOMENCLATURE

Berek Compensator (U-CBE)
Thick Berek Compensator (U-CTB)

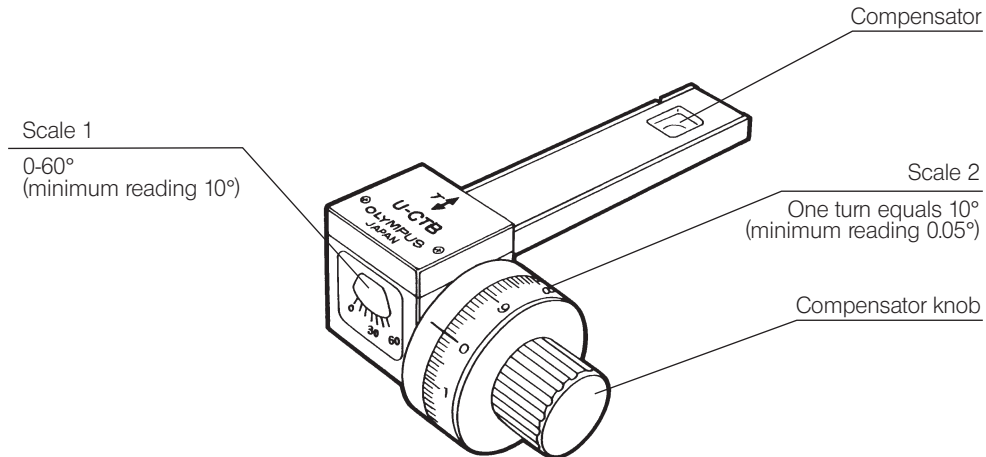

* The illustration shows the U-CTB. The U-CBE's γ axis direction is different.

U-CBR1, U-CBR2

Brace-Köhler Compensator (U-CBR1, U-CBR2)

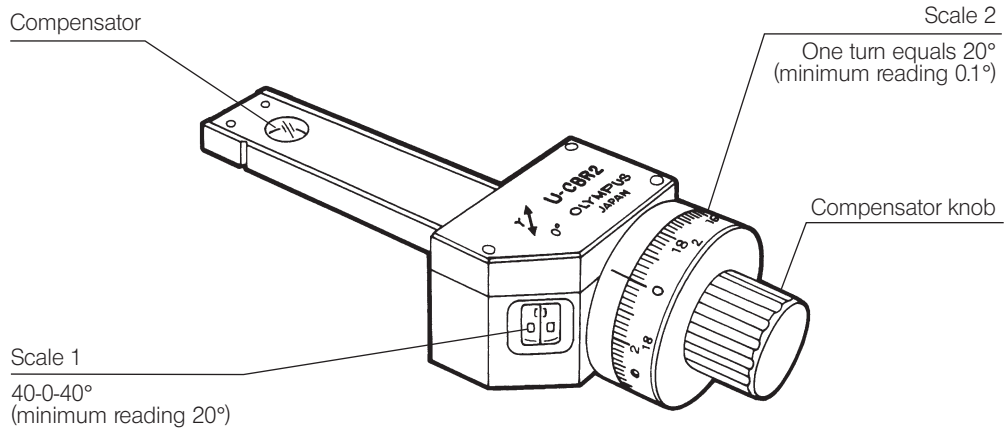

* The illustration shows the U-CBR2. The U-CBR1 is the model with the same design as the U-CBR2 but only the product name is different.

Quartz Wedge
(U-CWE2)

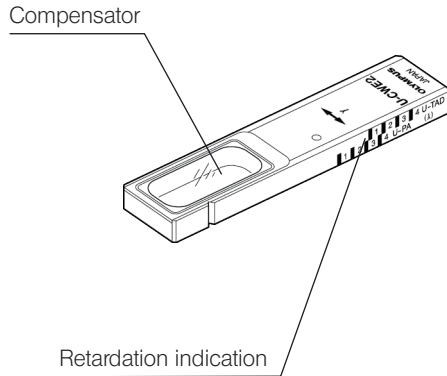

Senarmont Compensator
(U-CSE)

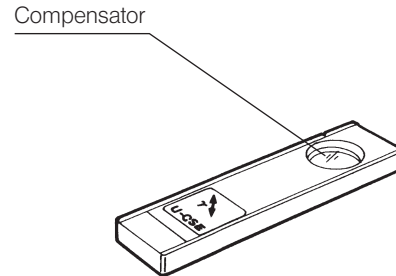

3 ASSEMBLY

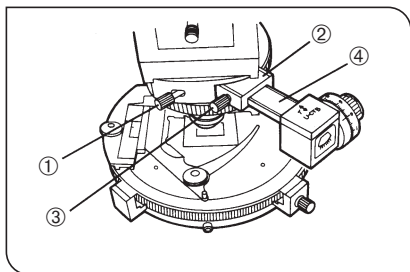

Fig. 1

- ⊙ The assembly method is the same for all the compensators. The compensator is designed to be inserted in the test plate adapter (U-TAD) or polarization attachment (U-PA).

With U-TAD

1. Loosen the clamping knob ① at the front of the revolving nosepiece and remove the dummy slider.
2. Insert the test plate adapter (U-TAD) ② and tighten the clamping knob ①.
3. Loosen the test plate adapter clamping knob ③ and insert the compensator ④ as far as the click-stop position (where the compensator is not engaged into the light path), then tighten the clamping knob ③.

With U-PA

1. Disengage the Bertrand lens from the light axis.
 2. Engage the analyzer in the light path and set the rotary scale to position "0".
 3. Push in the compensator as far as it will go, and then pull it slightly out until it stops in the click position.
- ★ If the compensator is inserted at a tilted position, it may impinge against the insertion slot. Always set to position 30°.
- ⊙ When measuring, insert the compensator one step further to position it in the light path.

Preparation for Measuring

- ⊙ Preparation for measuring is the same for all compensators.

1 Adjusting the Extinction

Perform the cross-Nikol adjustment and the eyepiece cross line alignment as described in the instruction manual for the polarizing microscope.

Note on Measuring:

- © Measuring is usually performed with the condenser's top-lens swung out and the aperture iris diaphragm stopped down. If it is required to maintain brightness and resolution, the top-lens should be left engaged although measuring accuracy will decrease.
- © When measuring retardation, backlash error may occur when the compensator knob is rotated (U-CBE, U-CTB, U-CBR1, U-CBR2). Accordingly, keep the rotation direction always uniform. If the knob is rotated too far, turn it fully back and restart rotation by keeping the direction uniform till the measured portion.

4-1 Berek Compensator (U-CBE), Thick Berek Compensator (U-CTB)

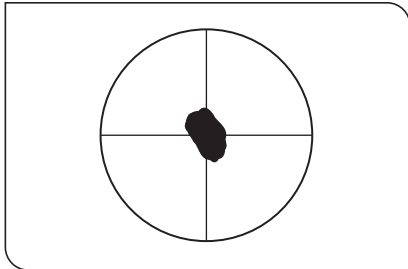

Fig. 2-1

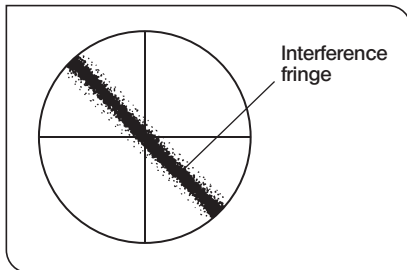

Fig. 2-2

Measuring

- ☉ If an interference filter (IF 546 or IF 550) is available, use of this filter will improve measurement accuracy.

1 Adjusting the Extinction

1. Position the specimen on the rotatable stage (U-SRP) and focus on the specimen.

2 Adjusting the Rotation Position

- ☉ Do not use the interference filter in this adjustment.
1. Rotate the stage until it attains the position of extinction (position where the observed portion of the specimen looks darkest).
 2. Rotate the stage further by $+45^\circ$ and then clamp it.
 3. Rotate the compensator knob and set the U-CBE or U-CTB scale to position 30° .
 4. Insert the U-CBE or U-CTB into the test plate adapter (U-TAD) or polarization attachment (U-PA) as far as it will go.

5. Rotate the compensator knob and confirm that the measured portion on the center of the specimen is dark as shown in Fig. 2-1 (Note). If it is not dark, rotate the stage by -90° and clamp.
(Note) Instead, a black interference may be observed with certain specimens (Fig. 2-2).

If the black fringe does not intersect the center of the field of view even after rotating the stage 90° , the retardation of the specimen is outside the measurable range, and measuring with the U-CBE or U-CTB is not possible. (See page 1)

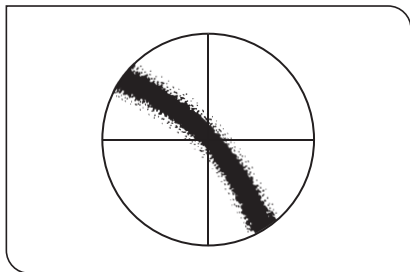

Fig. 3

3 Measuring Retardation

- ☉ If an interference filter (IF 546 or IF 550) is available, use it in this measurement.
1. Place an interference filter in the filter holder of the microscope frame.
 - ★ If an interference filter is used, multiple black dots or fringes will be visible. Use the black dot or fringe that is visible when the interference filter is not used.
 - To identify this dot or fringe, check the position of the black dot or fringe without using the filter before engaging it, then engage the interference filter and confirm the same black dot.
 2. Rotate the compensator knob to the position where the measured portion on the center of the field of view is darkest (Fig. 3) Find the angle at this position by totaling the readings of scales 1 and 2. $\rightarrow \theta_1$
 3. Rotate the compensator knob in the opposite direction and read the angle of the position with which the measured portion on the center of the field of view is darkest in the same manner as in step 2 above. $\rightarrow \theta_2$
 4. Repeat steps 2 and 3 several times, obtain the mean value of θ_1 , $\bar{\theta}_1$, and that of θ_2 , $\bar{\theta}_2$, and finally find the overall mean value θ using the following formula:

$$\theta = \frac{|\bar{\theta}_1 - \bar{\theta}_2|}{2}$$

5. After finding the mean value θ , use the conversion table provided with the compensator to find the retardation. The formula on the next page may also be used to find the retardation.

★ If on interference filter is used, use the data on the e-line of the conversion table.

$$\text{Retardation (nm)} = C \cdot \frac{2 \left| \sqrt{1 - \sin^2 \theta / \omega^2} - \sqrt{1 - \sin^2 \theta / \varepsilon^2} \right|}{\left| 1 / \varepsilon^2 - 1 / \omega^2 \right|}$$

$$C = \text{Invariables of compensator} = \frac{d \cdot \omega}{2} \left| \frac{1}{\varepsilon^2} - \frac{1}{\omega^2} \right| \left[\text{Shown in the attached conversion table.} \right]$$

ω, ε : Ordinary ray, extraordinary ray refraction

d : Prism thickness of compensator

		F - line $\lambda = 486.1 \text{ nm}$	e - line $\lambda = 546.1 \text{ nm}$	d - line $\lambda = 587.6 \text{ nm}$	C - line $\lambda = 656.3 \text{ nm}$
		U-CBE	$\omega =$ $\varepsilon =$	1.38020 1.39211	1.37859 1.39043
U-CTB	$\omega =$ $\varepsilon =$	1.66820 1.49092	1.66158 1.48762	1.65836 1.48633	1.65437 1.48459

4-2 Brace-Köhler Compensator (U-CBR1, U-CBR2)

Measuring the Fiducial Point

1. Insert the U-CBR1 or U-CBR2 into the test plate adapter (U-TAD) or polarization attachment (U-PA) as far as it will go.
2. Rotate the compensator knob to obtain extinction. At this point, find the angle by totaling the readings of Scales 1 and 2. $\rightarrow \theta_0$
3. Pull out the U-CBR1 or U-CBR2 to remove the compensator from the light path again.

Measuring

- © If an interference filter (IF 546 or IF 550) is available, use of this filter will improve measurement accuracy.

1 Specimen Placement

1. Position the specimen on the rotatable stage (U-SRP), in such a manner that the specimen center portion coincides with the intersection of the eyepiece cross lines, and focus on the specimen.

2 Measuring Retardation

1. Place an interference filter (IF 546) in the filter holder on the light exit of the microscope.
2. Rotate the stage until it attains the extinction position (where the observed portion of the specimen becomes dark).
3. Rotate the stage by $+45^\circ$ and then clamp it.
4. Loosen the test plate adapter (U-TAD) clamping knob, and insert the U-CBR1 or U-CBR2 as far as it will go. Then tighten the clamping knob.

(Tip)

γ axis direction (vibration direction in which the speed of the light becomes slower) when the specimen became dark when the digits on Scale 1 were rotated towards the black digits.

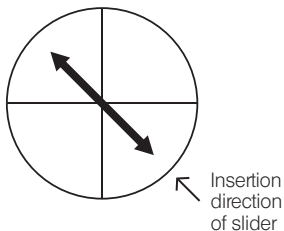

γ axis direction when the specimen became dark when rotating in direction of the green digits.

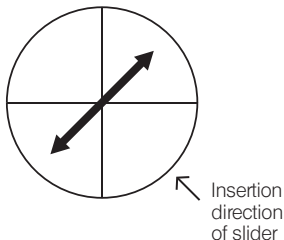

5. Rotate the compensator knob to adjust in such a manner that the point to be measured on the specimen attains extinction. At this point, read the angle. $\rightarrow \theta$

- If the reading on Scale 1 is indicated by black digits
 \Rightarrow Read the white digits on Scale 2.
- If the reading on Scale 1 is indicated by green digits
 \Rightarrow Read the green digits on Scale 2.
- ⊙ Find the angle by totaling the readings of Scales 1 and 2.

If the specimen does not become dark even after rotating the stage, the retardation of the specimen is outside the measurable range, and measuring with the U-CBR1 or U-CBR2 is not possible. (See page 1)

6. To find the retardation, insert the read angles into the following formula:

$$\text{Retardation (nm)} = R_0 \cdot \sin(2 \cdot |\theta - \theta_0|)$$

R_0 = Compensator constant (This can be found in the attached data sheet)

θ = Angle at the extinction position of the measuring point when the specimen is placed on the stage.

θ_0 = Angle when the field of view becomes dark when the specimen is not placed on the stage (fiducial point)

$$|\theta - \theta_0|$$

When the values of both θ and θ_0 are indicated by digits of the same color $\rightarrow \theta - \theta_0$

When the values of θ and θ_0 are indicated by digits of different colors $\rightarrow \theta + \theta_0$

Example:

- $\theta = 25.4^\circ$ (black), $\theta_0 = 0.5^\circ$ (black)

$$|\theta - \theta_0| = 25.4^\circ - 0.5^\circ = 24.9^\circ$$

- $\theta = 22.3^\circ$ (green), $\theta_0 = 0.2^\circ$ (black)

$$|\theta - \theta_0| = 22.3^\circ + 0.2^\circ = 22.5^\circ$$

4-3 Quarts Wedge (U-CWE2)

Measuring

(Note) Do not use the interference filter (IF 546 or IF 550) in the following measurement. Otherwise, the measurement will not be possible.

1 Specimen Placement

1. Position the specimen on the rotatable stage (U-SRP) and focus on the specimen.

2 Adjusting the Rotation Position

1. Rotate the stage until it attains the extinction position (where the observed portion of the specimen becomes dark).
2. Rotate the stage further by $+45^\circ$ and then clamp it.
3. Insert the U-CWE2 into the test plate adapter (U-TAD) or polarization attachment (U-PA). Slide the U-CWE2 and check whether there is a position where the specimen becomes dark. Note that, when the 4X or 10X objective is used, the specimen does not become dark even in the right position unless the aperture iris is stopped down. If the specimen cannot be made darker by stopping down the aperture iris, rotate the stage by -90° and clamp it.

If the specimen does not become dark even after rotating the stage 90° , the retardation of the specimen is outside the measurable $1-4 \lambda$ range, and measuring with the U-CWE2 is not possible. (See page 1)

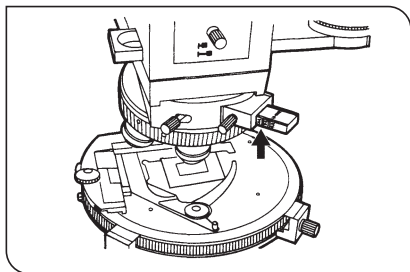

Fig. 4

3 Measuring Retardation

- ◎ The U-CWE2 indicates retardation values (1 to 4 λ) using two scales on the side. Read the reading of the scale for the module used (U-TAD or U-PA).
1. Slide the U-CWE2 and adjust so that the measuring point on the specimen becomes dark.
 2. At this point, note the value indication on the side of the U-CWE2 seen at the edge of the adapter. This reading shows the approximate range of the retardation at the measuring point. (Arrow indicated position Fig. 4)
 3. Based on this estimate and using the interference color chart (*), find the retardation by comparing the background color outside the measuring point and the color at the measuring point when the U-CWE2 is removed from the optical path.

(*) Download the file of interference color chart from OLYMPUS website (below mentioned URL).

<http://www.olympus-ims.com/microscope/bx-pol-chart>

The downloaded file includes multiple interference color charts which differ depending on the type of light source unit. Select the interference color chart applicable to your light source unit.

4-4 Senarmont Compensator (U-CSE)

Measuring

© Always use interference filter (IF 546 or IF 550). If interference filter is not used, measurement will not be possible.

★ Due to its high detection sensitivity, use of the IF546 interference filter is recommended.

1 Adjusting of Analyzer Angle

★ Perform the following adjustment with no specimen positioned on the stage.

1. Insert the U-CSE into the test plate adapter (U-TAD) or polarization attachment (U-PA) as far as it will go.
2. Fine adjust the polarizer of the condenser (U-POC) to obtain complete extinction.
3. Then fine adjust the rotatable analyzer (U-AN360P) to obtain complete extinction.
4. Repeat the steps 2 and 3 about 3 to 5 times.
5. At this point, read the analyzer's final angle. → θ_0

2 Specimen Placement

1. Position the specimen on the rotatable stage (U-SRP), in such a manner that the specimen center portion coincides with the intersection of the eyepiece cross lines, and focus on the specimen.

3 Adjusting the Fiducial Point

1. Rotate the stage and adjust so that the measured portion on the specimen becomes dark.
2. Rotate the stage by +45° and then clamp it.
3. Pull out the U-CSE from the test plate adapter (U-TAD) or polarization attachment (U-PA), push the test plate (U-TP530) into the U-TAD or U-PA and confirm that the interference color of the measured portion changes from the sensitive color to blue. If the color changes to red-orange-yellow instead of blue, rotate the stage by -90° and then clamp it. Now pull out the test plate from the U-TAD or U-PA.

4 Adjusting the Fiducial Point

1. Place an interference filter in the filter holder on the light exit of the microscope.
2. Rotate the analyzer dial and adjust so that the measuring point on the specimen becomes dark.
3. At this point, read the analyzer's angle. → θ
4. Find the retardation by using the following formula:

$$\text{Retardation (nm)} = \frac{546 \times |\theta - \theta_0|}{180^\circ}$$

MEMO

MEMO

This product is manufactured by **EVIDENT CORPORATION** effective as of Apr. 1, 2022.
Please contact our "Service Center" through the following website for any inquiries or issues related to this product.

EVIDENT CORPORATION

6666 Inatomi, Tatsuno-machi, Kamiina-gun, Nagano 399-0495, Japan

(Life science solutions)

Service Center

<https://www.olympus-lifescience.com/support/service/>



(Life science solutions)

Our Website

<https://www.olympus-lifescience.com>



(Industrial solutions)

Service Center

<https://www.olympus-ims.com/service-and-support/service-centers/>



(Industrial solutions)

Our Website

<https://www.olympus-ims.com>



AX5894 08

Issued in March, 2022