

OLYMPUS®

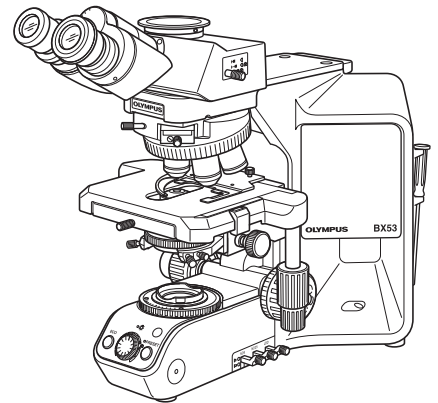

INSTRUCTIONS

BX53

SYSTEM MICROSCOPE

CE

This instruction manual is for the Olympus System Microscope Model BX53. To ensure the safety, obtain optimum performance and to familiarize yourself fully with the use of this microscope, we recommend that you study this manual thoroughly before operating the microscope. Retain this instruction manual in an easily accessible place near the work desk for future reference.

Optical Microscope and Accessory



AX7855



In accordance with European Directive on Waste Electrical and Electronic Equipment, this symbol indicates that the product must not be disposed of as unsorted municipal waste, but should be collected separately.

Refer to your local Olympus distributor in EU for return and/or collection systems available in your country.

NOTE: This equipment has been tested and found to comply with the limits for a Class A digital device, pursuant to Part 15 of the FCC Rules. These limits are designed to provide reasonable protection against harmful interference when the equipment is operated in a commercial environment. This equipment generates, uses, and can radiate radio frequency energy and, if not installed and used in accordance with the instruction manual, may cause harmful interference to radio communications.

Operation of this equipment in a residential area is likely to cause harmful interference in which case the user will be required to correct the interference at his own expense.

FCC WARNING: Changes or modifications not expressly approved by the party responsible for compliance could void the user's authority to operate the equipment.

For Korea only

B급 기기 (가정용 방송통신기자재)

이 기기는 가정용(B급) 전자파적합기기로서 주로 가정에서 사용하는 것을 목적으로 하며, 모든 지역에서 사용할 수 있습니다.

CONTENTS

Correct assembly and adjustments are critical for the microscope to exhibit its full performance. If you are going to assemble the microscope yourself, please read section 10, "ASSEMBLY" (pages 34 to 37) carefully.

IMPORTANT – Be sure to read this section for safe use of the equipment. – 1-3

1 MODULE NOMENCLATURE 4

2 CONTROLS 5-7

3 FLOW OF OBSERVATION 8,9

4 SIMPLIFIED OBSERVATION PROCEDURE 10-12

4-1 Basic Operation (Until Observation of Specimen)..... 10,11

4-2 Microscope Adjustments (How to Improve the Observed Image)..... 11,12

1 Adjusting the Interpupillary Distance..... 11 **2** Adjusting the Diopter 11

3 Adjusting the Centering..... 12 **4** Adjusting the Contrast..... 12

5 USING THE CONTROLS 13-26

5-1 Base..... 13-16

1 Adjusting the Brightness..... 13 **2** Using the Light Intensity Preset Switch..... 13

3 Using the ECO/NORMAL Switch..... 14 **4** Using the Filters..... 14-16

5-2 Focusing Block..... 17,18

1 Focusing Controls..... 17 **2** Adjusting the Focus..... 17

3 Replacing the Fine Adjustment Knob..... 18 **4** Adjusting the Coarse Adjustment Knob Tension..... 18

5 Pre-focusing Lever..... 18

5-3 Stage..... 19-21

1 Placing the Specimen..... 19 **2** Using the Auxiliary Slide Holder..... 19

3 Adjusting the X- and Y-Axis Knob Tension..... 20 **4** Rotating the Stage..... 21

5 Adjusting the Stage Height..... 21

5-4 Observation Tube..... 22-24

1 Adjusting the Diopter..... 22 **2** Using the Eye Shades..... 22

3 Mounting the Eyepiece Micrometer Disk..... 23 **4** Selecting the Light Path of the Trinocular Tube..... 23

5 Adjusting the Tilt..... 24 **6** Using Eyepieces Incorporating a Micrometer..... 25

5-5 Condenser..... 25

1 Compatibility of Objectives and Condensers..... 25

5-6 Immersion Objectives.....	26
1 Using Immersion Objectives.....	26
5-7 Objectives with Correction Collar.....	26

6	CAMERA RECORDING	27
7	TROUBLESHOOTING GUIDE	28-30
8	SPECIFICATIONS	31,32
9	OPTICAL CHARACTERISTICS (UIS2 Series)	33
10	ASSEMBLY – See this section for the replacement of the light bulb. –	34-37
11	PREVENTIVE INSPECTION SHEET FOR ILLUMINATION DEVICES	38
	■ PROPER SELECTION OF THE POWER SUPPLY CORD.....	39,40

IMPORTANT

This microscope employs a UIS2 (Universal Infinity System) optical design, and should be used only with UIS2 eyepieces, objectives and condensers for the BX2 series. (Some of the modules designed for the BX series and objectives/eyepieces for the UIS series are also usable. For details, please consult Olympus or the catalogues.) Less than optimum performance may result if inappropriate accessories are used.



SAFETY PRECAUTIONS

(Fig. 1)

1. If potentially infectious samples may be observed, use protective gloves or other protective means to prevent the skin from contacting with samples directly.
After observation, be sure to clean the portion contacted with samples.
 - Moving this product is accompanied with the risk of dropping the sample. Be sure to remove the sample before moving this product.
 - In case the sample is damaged by erroneous operation, promptly take the infection prevention measures.
 - Follow the procedures described in Chapter “Getting Ready” (see on page 2) prior to using the accessories of this product. Otherwise, the stability of the device will be lost and the dropped sample will cause the possibility of infection.
 - When you maintain the device which may have contacted with potentially infectious reagents, be sure to wear the protectors such as gloves, or clean the device prior to operation.
 - Before disposing of device contacted with potentially infectious samples, be sure to follow the regulations and rules of your local government.
2. Install the microscope on a sturdy, level table or bench.
In particular, do not put the mat or so under the microscope for safety purpose.
3. Be careful not to tilt the microscope too much. Otherwise, the mobile parts such as the light path selector knob may move in unintended directions.
4. The surfaces of the lamp housing on the rear of the microscope will become extremely hot during operation.
When installing the microscope, make sure to allow ample free space around and in particular above the halogen lamp housing.
After the microscope is installed, make sure that the space under the lamp housing is ensured.
5. When installing the microscope, route the power cord away from the lamp housing. Should the power cord come in contact with the hot lamp housing, the power cord could melt and cause electric shock.
6. To avoid potential shock hazards and burns when replacing the light bulb, set the main switch ① to “○” (OFF) then disconnect the power cord from the wall outlet in advance. Whenever you replace the bulb during use or right after use, allow the lamp housing, and bulb to cool before touching. (Fig. 1)

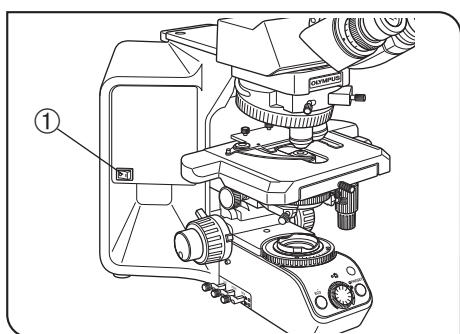

Fig. 1

Designated bulb	12V100WHAL-L (PHILIPS 7724)
-----------------	-----------------------------

CAUTION

Always use the designated lamp bulb. Using other bulb may cause malfunction.

7. Always use the power cord provided by Olympus. If no power cord is provided, please select the proper power cord by referring to the section “PROPER SELECTION OF THE POWER SUPPLY CORD” at the end of this instruction manual. If the proper power cord is not used, product safety performance cannot be warranted.
8. Always ensure that the **grounding terminal** of the microscope and that of the wall outlet are properly connected. If the equipment is not grounded, Olympus can no longer warrant the electrical safety performance of the equipment.
9. Never insert metallic objects into the air vents of the microscope frame as this could result in electrical shock, personal injury and equipment damage.
10. The standard service life of the lamp housing is eight (8) years of use or 20,000 hours of total power ON period, whichever is the shorter period. For details, see Inspection Sheet on page 38.





Restrictions in Use

When all combinations (① to ③) below are satisfied at the same time, the microscope may fall if tilted larger than a certain degree, comparing to other combinations. Please mount the camera port of the intermediate observation tube toward diagonally backward 45° to prevent from falling.

- ① The observation tube is either the trinocular tube, U-TTBI, U-ETBI or U-TTLBI.
- ② The intermediate observation tube is either U-TRUS or U-DP.
- ③ The camera heavier than 0.4kg is mounted on the intermediate observation tube described in ②.



Safety Symbols

The following symbols are found on the microscope. Study the meaning of the symbols and always use the equipment in the safest possible manner.

Symbol	Explanation
	Indicates that the surface becomes hot, and should not be touched with bare hands.
	Indicates a non-specific general hazard. Follow the description given after this symbol or in instruction manual.
	Indicates that the main switch is ON.
	Indicates that the main switch is OFF.

Caution indications

Caution labels are placed at parts where special precaution is required when handling and using the microscope. Always heed the cautions.

Caution label position	Lamp housing [Caution against high temperature]	
Caution label position	Rear panel [Caution against high temperature]	

If a caution label is dirty or peeled off, contact Olympus for the replacement or other inquiry.

1 Getting Ready

(Fig. 2)

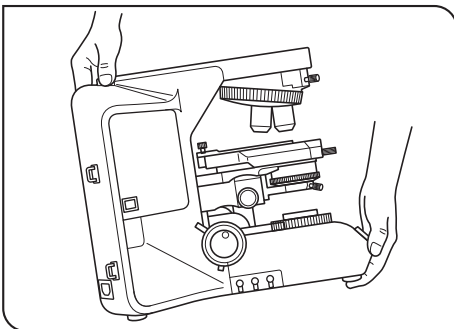

Fig. 2

1. A microscope is a precision instrument. Handle it with care and avoid subjecting it to sudden or severe impact. Also note that the microscope does not have a waterproof construction.
2. Do not use the microscope where it is subjected to direct sunlight, high temperature and humidity, dust or vibrations. (For the operating conditions, refer to section 8, "SPECIFICATIONS".)
3. When moving the microscope, remove the observation and specimen and carefully carry the microscope by holding the grasping part on the rear of the arm and the front part of the base as shown in Fig. 2.

CAUTION

To prevent damage to the microscope, never hold it by the stage or coarse/fine adjustment knob.

- Even when moving the microscope along the desktop surface, be sure to remove the specimen in advance.
- When the microscope needs to be packaged for forwarding to a remote location, contact Olympus.

Please do not lift up the microscope by holding the bottom side of the power supply cover (black) located on the rear panel.

4. When the accessories of this product are used, make sure that the system height does not exceed 1 meter. Otherwise, the stability of the device will be lost.
5. When an arm, illuminator, intermediate attachment, observation tube and camera are to be attached to the upper part of the microscope frame, make sure that their total weight does not exceed 18 kg.

2 Maintenance and Storage

1. To clean the lenses and other glass components, simply blow dirt away using a commercially available blower and wipe gently using a piece of cleaning paper (or clean gauze).

If a lens is stained with fingerprints or oil smudges, wipe it gauze slightly moistened with commercially available absolute alcohol.

- CAUTION**
- Since the absolute alcohol is highly flammable, it must be handled carefully. Be sure to keep it away from open flames or potential sources of electrical sparks — for example, electrical equipment that is being switched on or off, which could cause ignition of a fire. Also remember to always use it only in a well-ventilated room.
 - Set the main switch to “○” (OFF) and wait for the lamp housing to cool down sufficiently before proceeding to maintenance.

2. Do not use organic solvents to clean the microscope components other than the glass components. To clean them, use a lint-free, soft cloth slightly moistened with a diluted neutral detergent.
3. Do not disassemble any part of the microscope except for the parts that are specified to be disassembled in this manual, as this could result in malfunction or reduced performance.
4. After using the microscope, set the main switch to “○” (OFF), wait for the lamp housing to cool down sufficiently, and keep it covered with a dust cover during storage.
5. Before disposing of this product, be sure to follow the regulations and rules of your local government.

3 Caution

If the microscope is used in a manner not specified by this manual, the safety of the user may be imperiled. In addition, the equipment may also be damaged. Always use the equipment as outlined in this instruction manual.

The following symbols are used to set off text in this instruction manual.

- CAUTION** : Indicates a potentially hazardous situation which, if not avoided, may result in minor or moderate injury or damage to the equipment or other property. It may also be used to alert against unsafe practices.
- ⊙ : Indicates commentary (for ease of operation and maintenance).

4 Intended use

This product has been designed to be used to observe magnified images of specimens in various routine work and research applications.

This includes the observation of living cells or of specimen taken from tissues to gain physiological or morphological information at hospitals or laboratories. Typical field of applications are genetics, human blood and tissue examination, neurology, pharmacology and cellular biology.

Do not use this instrument for any purpose other than its intended use.



This device complies with the requirements of directive 98/79/EC concerning in vitro diagnostic medical devices. CE marking means the conformity to the directive.

This equipment has been designed and tested to CISPR 11 Class A. In a domestic environment it may cause radio interference, in which case, you may need to take measures to mitigate interference.

This system complies with the requirements of EMC standard IEC/EN61326-2-6 and IEC/EN61326-1 concerning electromagnetic compatibility.

This device complies with the emission and immunity requirements described in IEC61326 series. The electromagnetic environment should be evaluated prior to operation of this device. Do not use this device in close proximity to the sources of strong electromagnetic radiation to prevent interference with the proper operation.

1 MODULE NOMENCLATURE

©The modules mentioned below show only the typical product names. As there are some products that are not mentioned but also applicable to this microscope, check the latest catalogues or consult Olympus.
For the products marked “ * ”, also read their instruction manuals.

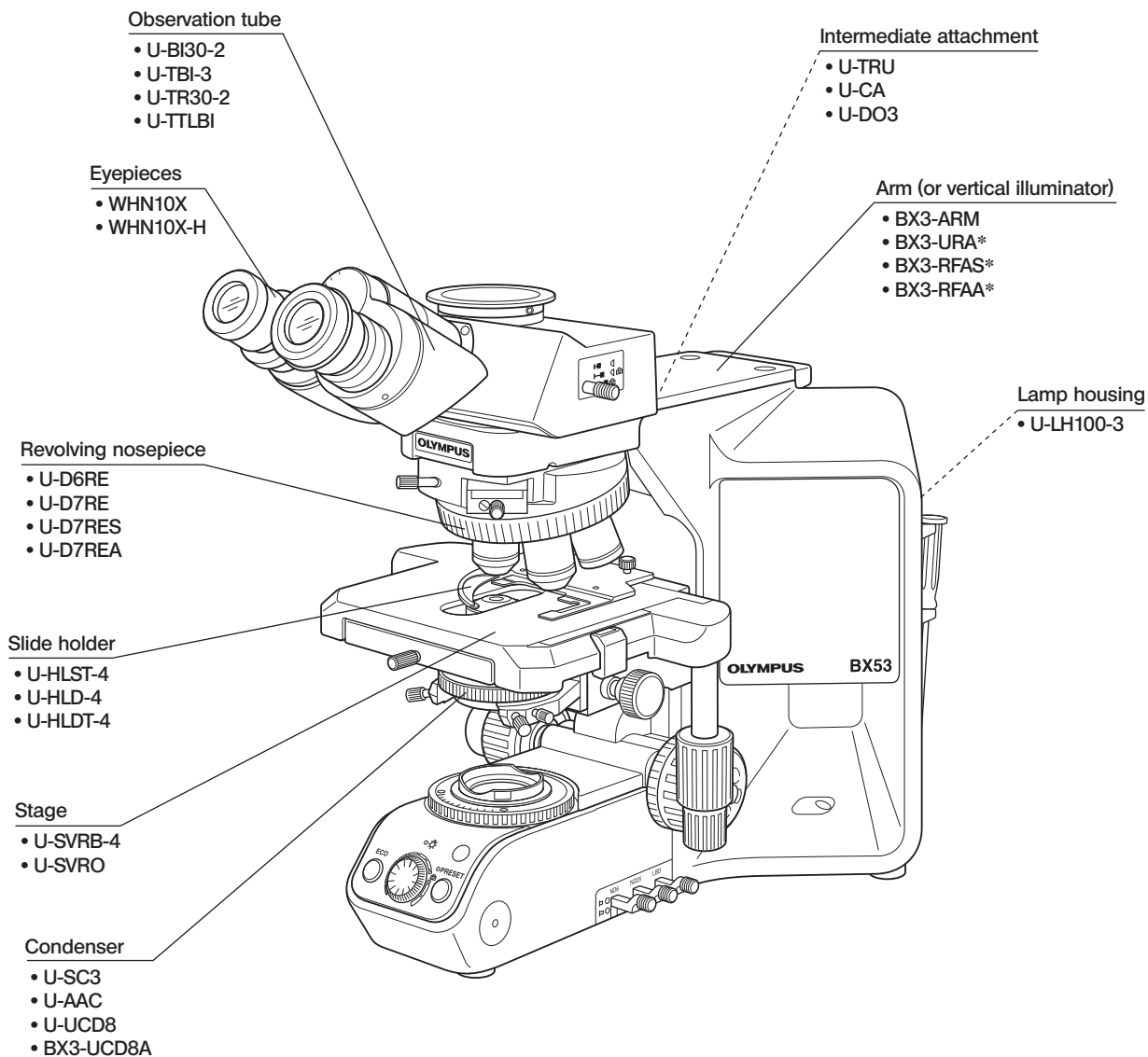

2 CONTROLS

© If you have not yet assembled the microscope, read section 10, "ASSEMBLY" (pages 34 to 37).

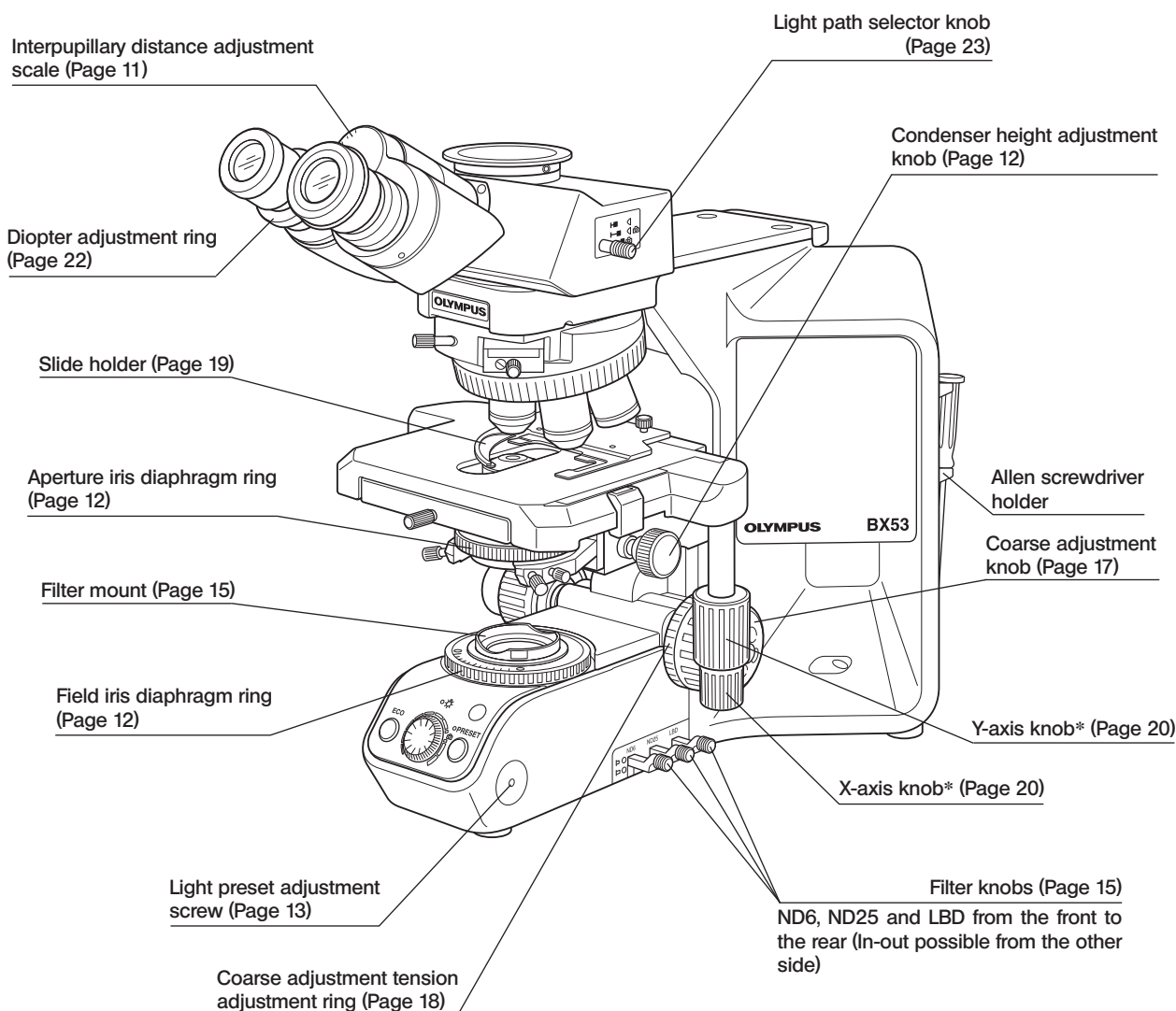

* The U-SHG (thin type) and U-SHGT (thick type) stage feed knob rubber caps can be attached optionally.

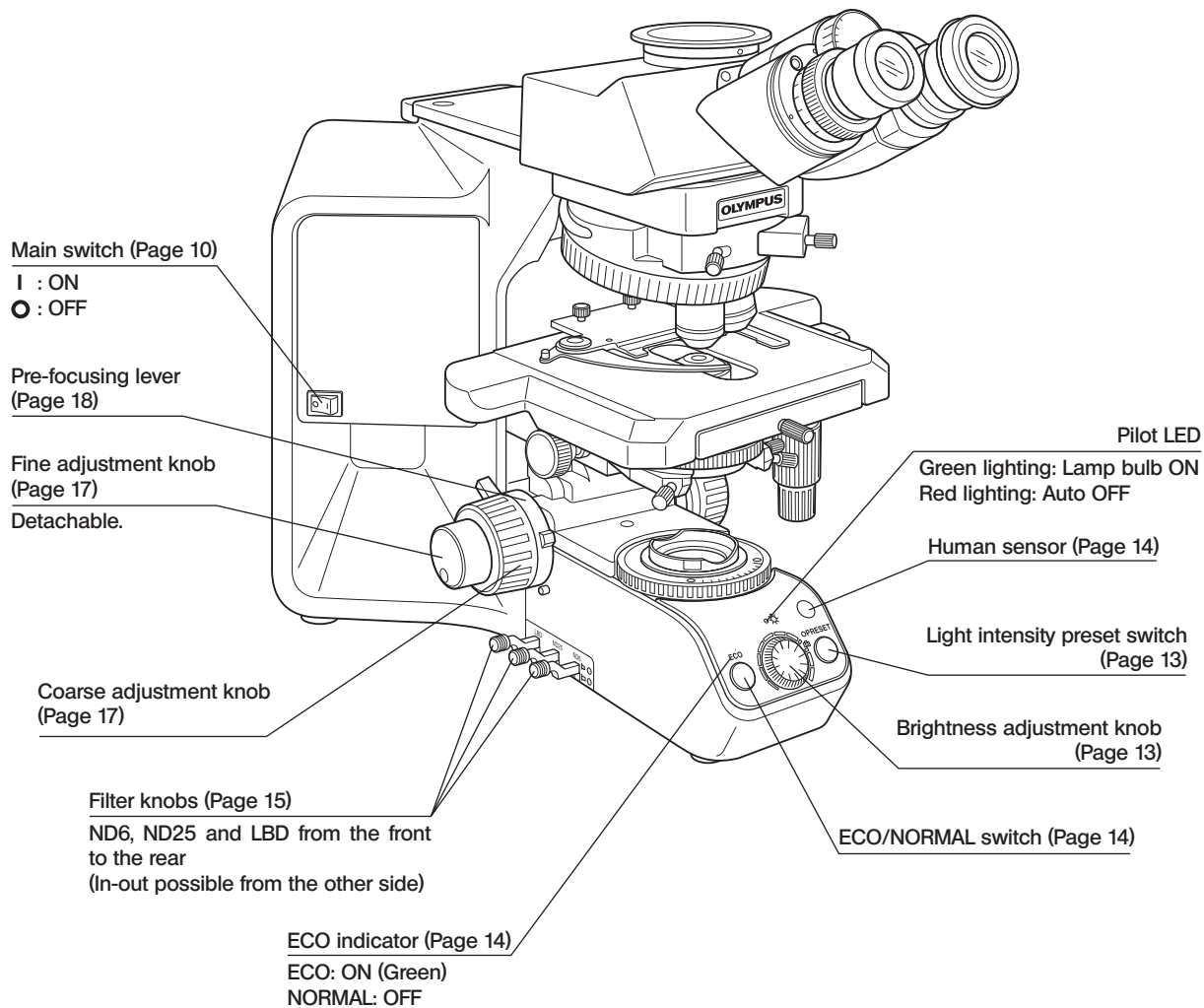

**Low Magnification Condenser
U-LC**

**Swing-out Condenser
U-SC3**

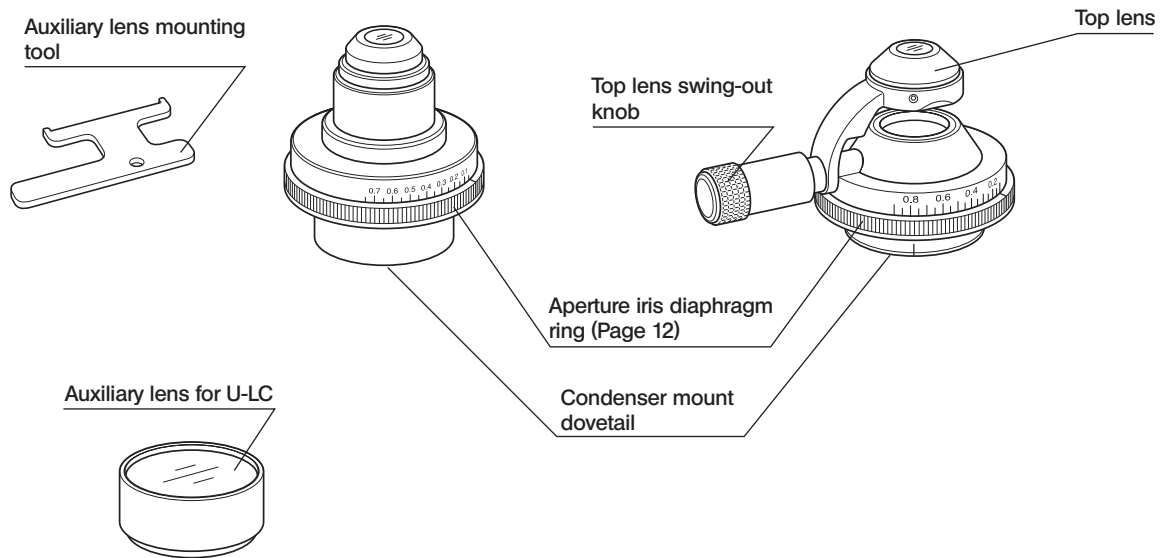

* The auxiliary lens is mounted on the lamp adapter when the U-LC is used. (Page 35)

3 FLOW OF OBSERVATION

©When the ECO mode is set, the halogen bulb turns OFF automatically in about 30 minutes the microscope becomes unattended.

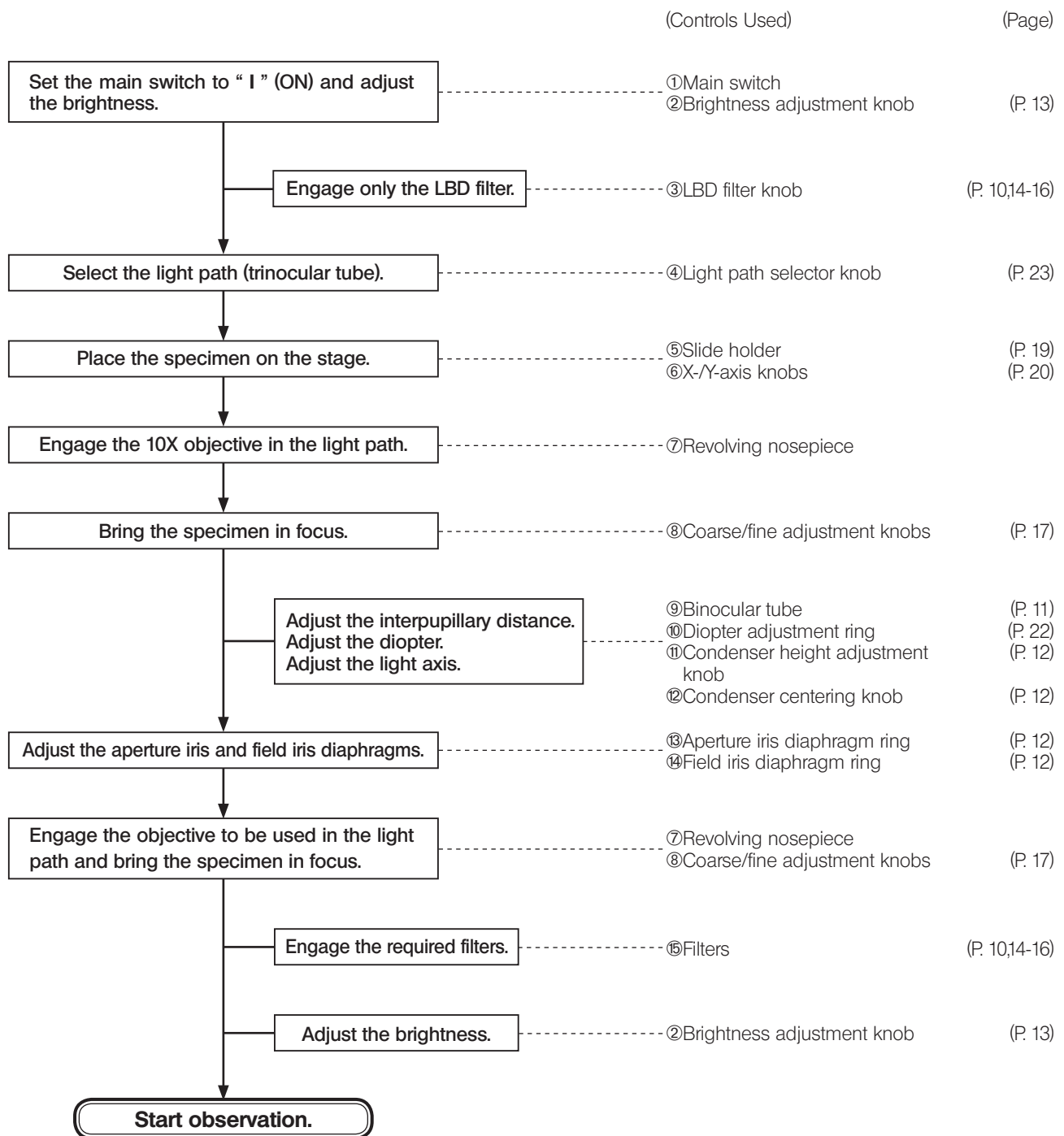

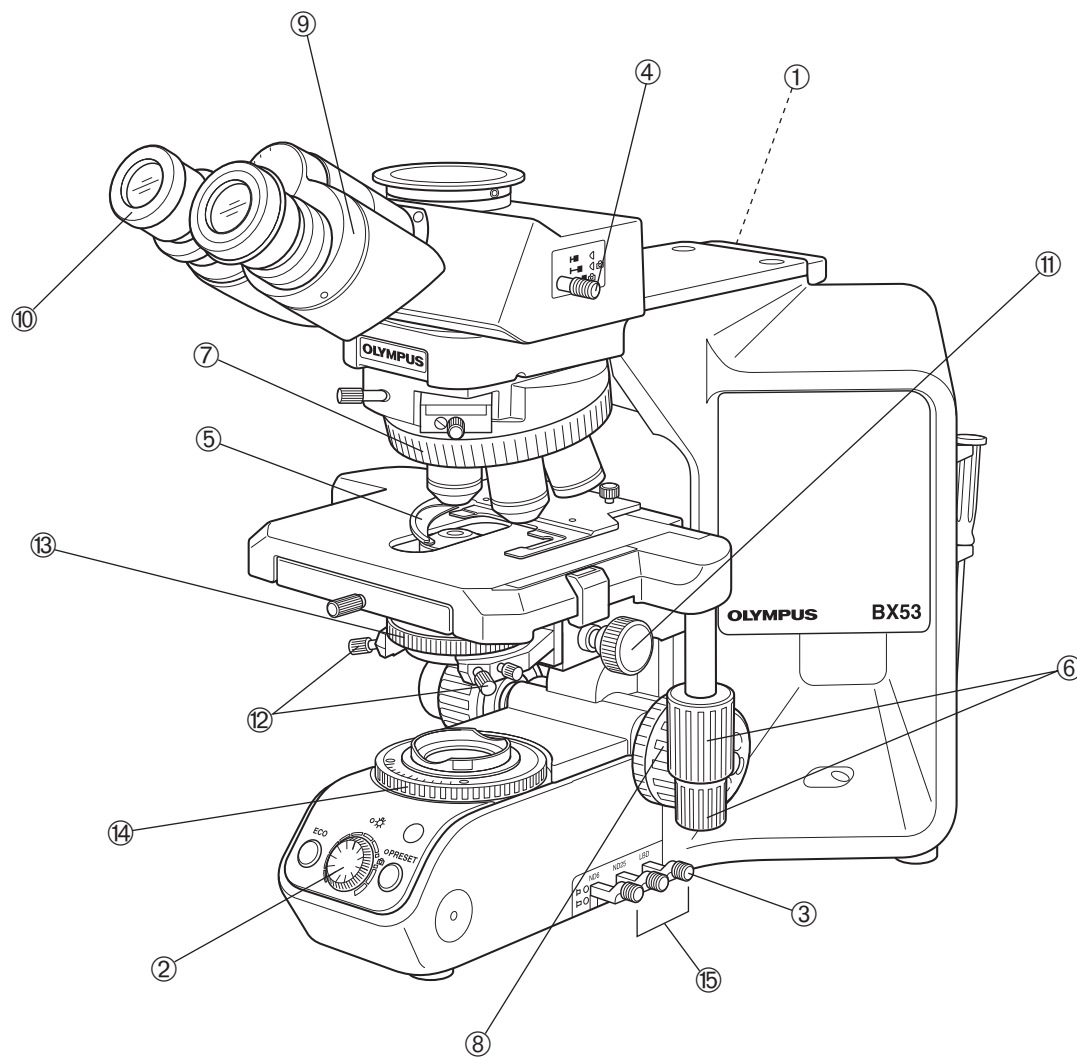

© Copy the observation procedure pages on separate sheets and post it near your microscope.

4 SIMPLIFIED OBSERVATION PROCEDURE

4-1 Basic Operation (Until Observation of Specimen)

This section describes the basic operation of the microscope until the start of observation of a specimen. For the detailed operating procedure of each control, please read the description page specified below.

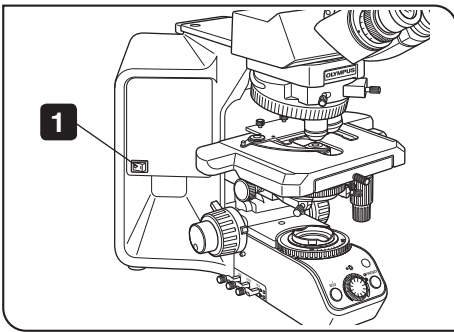

Fig. 3

- 1 Press the main switch of the microscope frame to “I” (ON).

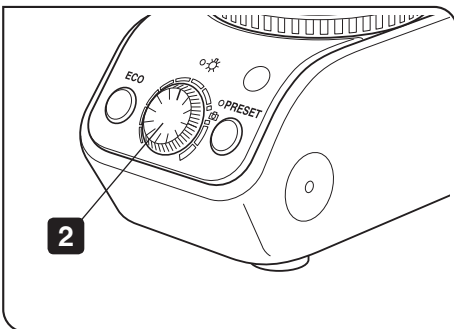

Fig. 4

- 2 Rotate the knob to adjust the lamp brightness. (Details: Page 13)

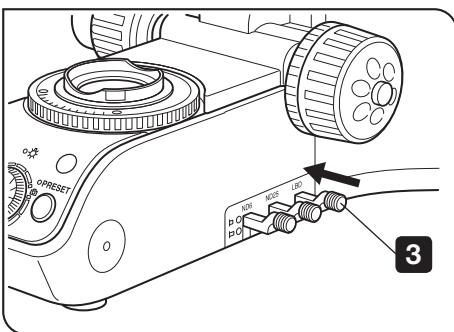

Fig. 5

- 3 Push in the LBD filter knob to engage the LBD filter in the light path. (Details: Page 15)

What is LBD filter?

The color of the sun at the noon of a clear day is called the daylight color, which looks white to human eyes. On the other hand, the halogen bulb used as the light source of this microscope does not emit the daylight-color light, so the LBD filter is engaged in the light path to convert the color of halogen bulb light into daylight. In general, engaging the LBD filter makes it possible to observe specimens in natural color tones.

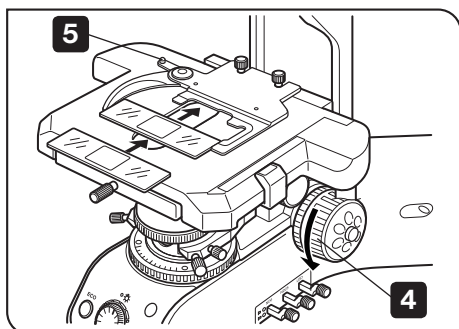

Fig. 6

- 4** Rotate the knob to lower the stage. (Details: Page 17)
- 5** Open the clamping lever of the slide holder and place the specimen slide. (Details: Page 19)

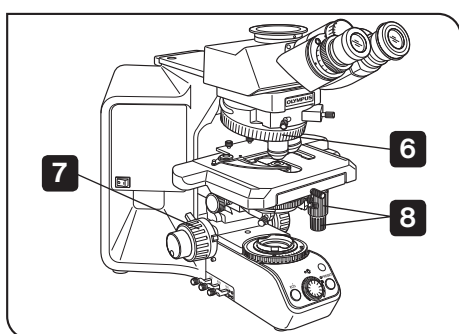

Fig. 7

- 6** Rotate the revolving nosepiece to engage the 10X objective in the light path.
- 7** Rotate the coarse and fine adjustment knobs to bring the specimen into focus. (Details: Page 17)
- 8** Rotate the stage knob to adjust the observation position.

Now you can observe the magnified image of the specimen. To improve the observation further, read section 4-2, "Microscope Adjustments" below.

4-2 Microscope Adjustments (How to Improve the Observed Image)

Adjust the microscope as described below to improve the observed image.

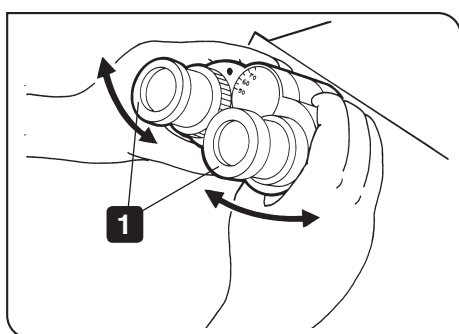

Fig. 8

1 Adjusting the Interpupillary Distance

- 1** While looking through the eyepieces, adjust for binocular vision until the left and right fields of view coincide completely.
 © Note your interpupillary distance so that it can be quickly duplicated.

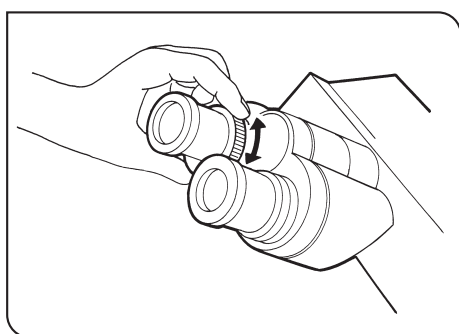
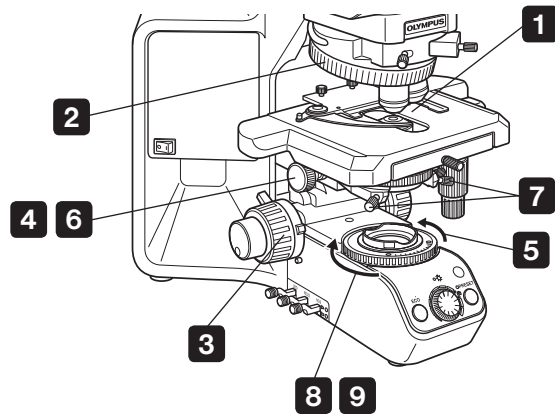

Fig. 9

2 Adjusting the Diopter

The diopter adjustment ensures parfocality from low to high magnifications and makes it possible to avoid defocusing even when the objective is switched.
 For details, see page 22.

3 Adjusting the Centering



- 1** Place the specimen.
- 2** Rotate the revolving nosepiece to select the 10X objective.
- 3** Rotate the knobs to bring the specimen into focus.
- 4** Rotate the knob to raise the condenser to its upper limit.
- 5** Rotate the field iris diaphragm ring in the direction of the arrow so that the diaphragm image comes inside the field of view.
- 6** Rotate the knobs to focus on the field iris diaphragm image (A in Fig. 10).
- 7** Turn the two condenser centering screws to move the iris diaphragm image to the center of the field of view (B in Fig. 10).
- 8** Gradually open the field iris diaphragm until its image is inscribed in the field of view (C in Fig. 10).
- 9** Open the field diaphragm slightly until its image circumscribes the field of view slightly (D in Fig. 10).

⊙ Be careful not to rotate the condenser clamping screw, located behind the centering knobs, by mistake.

⊙ When using a condenser with top lens such as the U-SC3, engage the top lens in the light path before proceeding to the centering adjustment.

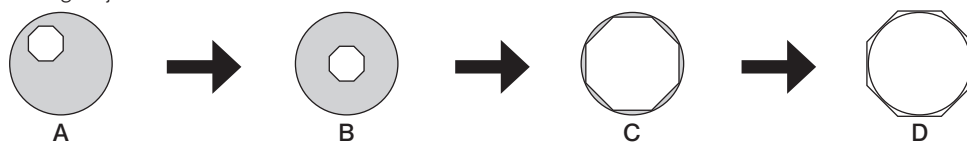
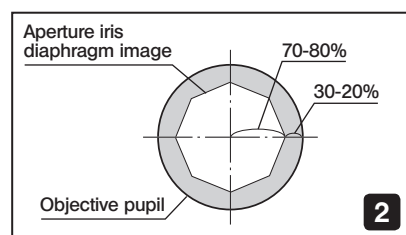
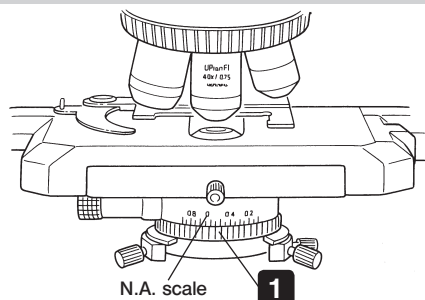

Fig. 10 Movement of Field Iris Diaphragm Image

4 Adjusting the Contrast



- 1** Set the condenser aperture iris diaphragm ring so that the condenser NA scale position indicates 70% of the NA of the objective in use. After this, observe the image and fine adjust the aperture iris diaphragm to the desired condition.
- 2** The image of the aperture iris diaphragm can be viewed by removing the eyepieces and looking into the observation tube. Adjust so that the image looks approximately like that shown in the figure above.

5 USING THE CONTROLS

5-1 Base

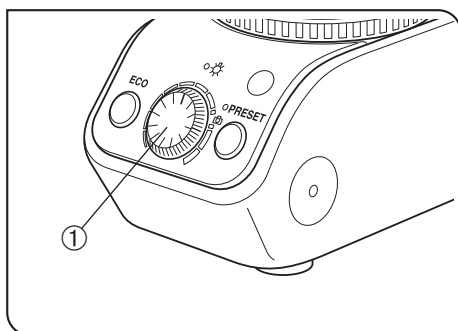

Fig. 11

1 Adjusting the Brightness (Fig. 11)

Turn the brightness adjustment knob ① clockwise to increase the voltage and make illumination brighter.

Ⓞ When the brightness adjustment knob ① is adjusted to the camera symbol marking, the brightness of the light becomes the daylight (color temperature of about 5500K). However, note that the daylight may not always be reproduced accurately depending on the degree of bulb consumption, etc.

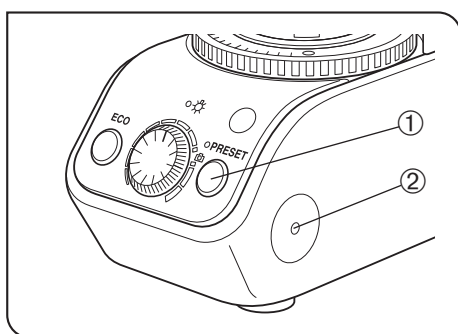

Fig. 12

2 Using the Light Intensity Preset Switch (Fig. 12)

The light intensity preset switch ① makes it possible to limit the light intensity to a preselected level regardless of the position of the brightness adjustment knob.

The light intensity preset has been preset to optimum brightness for photography when the built-in LBD filter is engaged (approx. 9 V with marking).

1. Press the light intensity preset switch ① to the ON position. (The face of the switch lights when it is ON.)
2. Using a small flat-blade screwdriver, turn the preset adjustment screw ② to obtain the required light intensity. Turning the screw clockwise increases brightness.
3. When the light intensity preset switch ① is set to OFF, the brightness returns to the level set by the brightness adjustment knob.

Ⓞ While the light intensity preset switch is ON, turning the light brightness adjustment knob does not affect brightness.

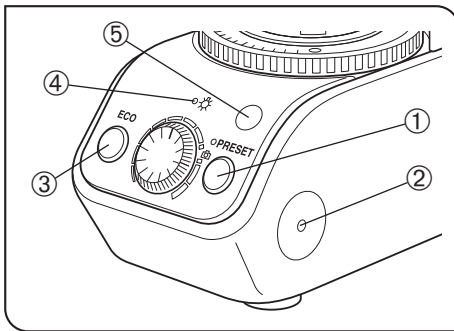

Fig. 13

3 Using the ECO/NORMAL Switch (Fig. 13)

Ⓞ The ECO mode helps prevent leaving the halogen bulb ON while the microscope is not used.

1. Press the ECO/NORMAL switch ③ to ON (so that the PILOT lamp ④ lights in green). Hereafter, when the human sensor ⑤ of the microscope has not detected human motion, etc. for more than about 30 minutes, the lighting halogen bulb is turned OFF automatically (the PILOT lamp ④ lights in red).
2. To turn the bulb ON again after it has been turned OFF automatically:
 - Set the main switch to “O” (OFF) then “I” (ON) again.
 - Press the ECO/NORMAL switch ③ twice.

Ⓞ In the ECO mode, the human sensor may sometimes be unable to detect a human body and the halogen bulb be turned OFF during use of the microscope in the following cases.

- When the heat source (human skin, etc.) in the detection range of the human sensor hardly moves or moves at a high speed.
- When far-IR rays from the sun or incandescent lamp is directly incident on the human sensor.
- When an object that transmits little far-IR rays, such as glass or acrylic plate, is located between the human sensor and the person operating the microscope.
- When there is little difference between the ambient temperature and the body temperature of the person.

Ⓞ In the ECO mode, the halogen bulb may not be turned OFF automatically in the following cases. In addition to these cases, the halogen bulb may neither be turned OFF in the case of sensor detection error.

- When the sensor detects the movement of a heat source other than human body.
- When the sensor detects a heat source that repeats heat generation, such as a motor repeating ON-OFF.
- When the temperature in the detection area changes suddenly, for example due to hot/cold winds of an air conditioner or vapor from a room humidifier.

4 Using the Filters (Figs. 14 to 20)

Ⓞ You can place a filter in the light path with one of the following methods.

- Push in the knob of the desired built-in filter to engage it in the light path. (Page 15)
- Place a filter on the filter mount on the base and engage in the light path. (Page 15)
- Insert a filter in the U-FC filter cassette, attach it on the filter mount and engage it in the light path by sliding the filter lever. (Page 15)

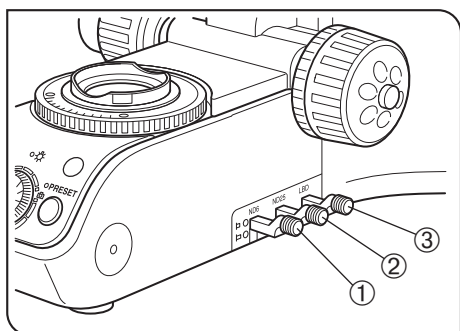

Fig. 14

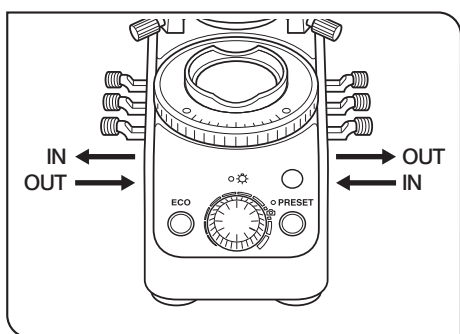

Fig. 15

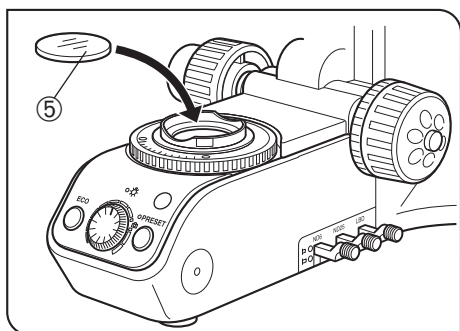

Fig. 16

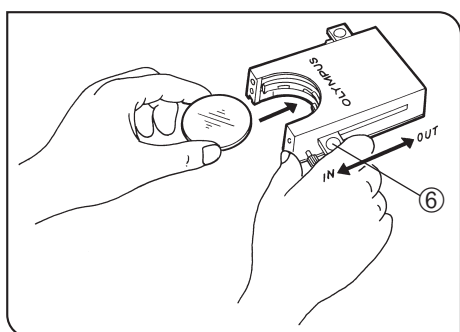

Fig. 17

Using Built-In Filters (Figs. 14 & 15)

Use the filter knobs to engage or disengage the corresponding filters into or from the light path.

	Filter Type/Purpose
①	ND6 (Neutral Density filter for light adjustment, transmittance 6%)
②	ND25 (Neutral Density filter for light adjustment, transmittance 25%)
③	LBD (for color balancing, daylight filter)

Assuming that you face the microscope from the front panel, push in a filter knob on the right or pull out a filter knob on the left to engage the corresponding filter in the light path. The filter can be disengaged from the light path by reversing the above.

⊙ When pushing in a filter knob, push it all the way to ensure engagement of the corresponding filter. If the filter is engaged incompletely, optimum observation may be impossible.

Mounting a Single Filter (Fig. 16)

A filter with a diameter of $\phi 45$ mm ⑤ can be placed on the filter mount on the base. If you need to place multiple filters, please purchase the U-FC filter cassette.

CAUTION Even when a filter cassette is used, a filter with thickness of no more than 3 mm can still be placed on the filter mount.

Using the Filter Cassette (Figs. 17 to 20)

Loading Filters into Filter Cassette

- ⊙ The filter cassette accommodates filters with a diameter of $\phi 45$ mm and thickness of 2.7 mm or less.
 - ⊙ The filter cassette has two filter levels on the right side and one on the left side.
 - ⊙ When the filter cassette is used, the ECO mode cannot be used because the human sensor is hidden by the filter cassette.
1. Move all filter levers to the OUT position except for the one belonging to the slot into which the filter is to be inserted.
 2. Slide the lever ⑥ to the IN position. Make sure that it clicks securely into place. (Fig. 17)
 3. Holding the lever in the position shown in Fig. 17, put the filter into the cassette by inserting it in the direction indicated by the arrow.
 4. Insert the other two filters in the same manner.

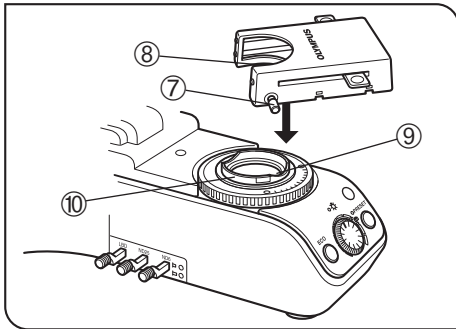

Fig. 18

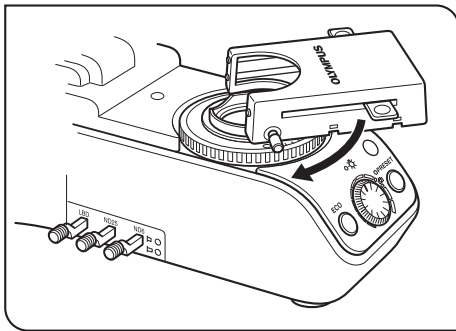

Fig. 19

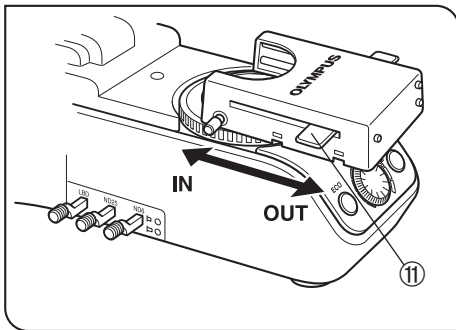

Fig. 20

Mounting the Filter Cassette

1. Fully loosen the filter cassette clamping screw ⑦. (Fig. 18)
2. Align the key ⑧ on the bottom surface of the filter cassette with the positioning slot ⑨ on the filter mount, then snap the filter cassette into place from above.
3. Rotate the filter cassette to align its sides with the base. (Fig. 19)
4. Align the clamping screw ⑦ with the positioning hole ⑩ on the filter mount, then tighten the screw to fasten the filter cassette.

CAUTION

When the filter cassette is installed, the stage may hit it when lowered. Therefore, exercise caution when lowering the stage with the filter cassette installed.

Using the Filter Cassette (Fig. 20)

Usable Filters	Applications	
45-ND6, 45-ND25	Neutral density filter	
45G-530, 43IF550-W45	Green	B&W contrast filters
45O-560	Orange	

Up to three of the above filters can be loaded in the filter cassette. Moving the levers ⑪ on the left and right sides of the cassette to the IN position brings the corresponding filter into the light path.

5-2 Focusing Block

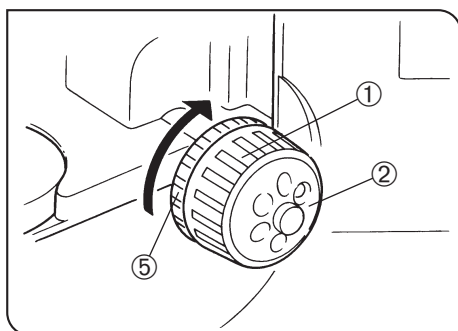

Fig. 21

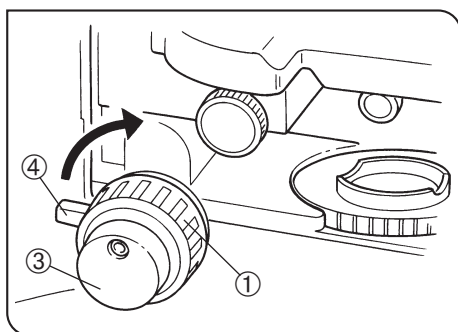

Fig. 22

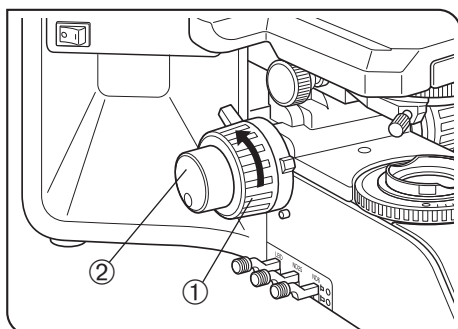

Fig. 23

1 Focusing Controls (Figs. 21 & 22)

The focusing block consists of the controls listed in the following table, which also describes the functions of the controls.

No.	Name	Function
①	Coarse adjustment knob	Moves the focus position widely.
②	Fine adjustment dial	Fine adjusts the focus position.
③	Fine adjustment knob	Fine adjusts the focus position. This knob can be attached to the fine adjustment dial on either the left or right side. (When the microscope is shipped, it is attached to the right-side dial.)
④	Pre-focusing lever	Sets the upper limit of the stage position (to prevent contact between the specimen and objective).
⑤	Tension adjustment ring	Adjusts the force required to rotate the coarse adjustment knob.

2 Adjusting the Focus (Fig. 23)

With both the coarse adjustment knob ① and fine adjustment knob ②, rotating the knob in the direction of the arrow raises the stage (lets the specimen approach the objective).

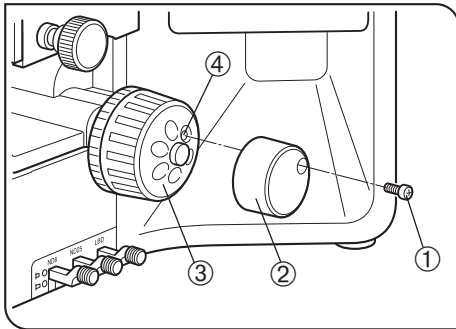

Fig. 24

3 Replacing the Fine Adjustment Knob (Fig. 24)

CAUTION The fine adjustment knob has been attached on the right side at the factory.

⊙ The fine adjustment knob is designed detachable to prevent interference with hand during manipulation of the fine adjustment knob or X-/Y-axis knobs.

Usually attach the knob on the opposite side to the X- and Y-axis knobs.

1. Using the Allen screwdriver, loosen the clamping screw ① and remove the fine adjustment knob ②.
2. Remove the seal from the fine adjustment knob screw hole on the other side and attach the knob by reversing the removal procedure.
3. Attach a provided seal on the screw hole ④ of the removed fine adjustment knob.

The fine adjustment dial ③ can be operated with your fingertip or finger surface at the same time as manipulating the X- or Y-axis knob.

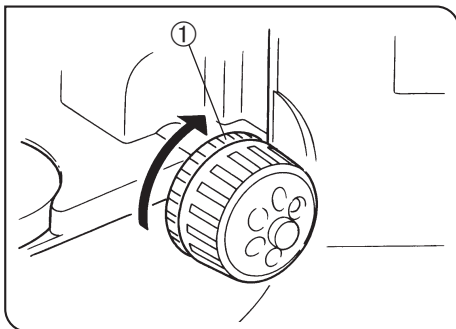

Fig. 25

4 Adjusting the Coarse Adjustment Knob Tension (Fig. 25)

CAUTION Adjust the coarse adjustment knob tension using the tension adjustment ring ①.

The coarse adjustment knob tension is preadjusted for easy use. However, if desired, you can change the tension using the tension adjustment ring ①. Turning the ring in the direction of the arrow increases tension, and vice versa.

The tension is too low if the stage drops by itself or focus is quickly lost after adjustment with the fine adjustment knob. In this case, turn the ring in the direction of the arrow to increase tension.

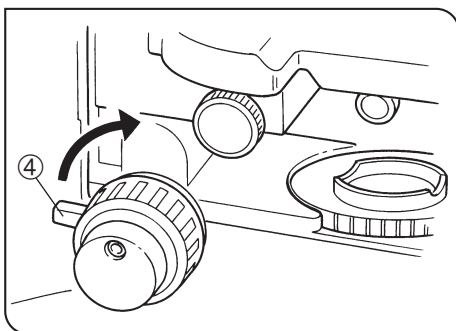

Fig. 26

5 Pre-focusing Lever (Fig. 26)

⊙ The pre-focusing lever ensures that the objective does not come in contact with the specimen and simplifies focusing.

After focusing on the specimen with the coarse adjustment knob, turn this lever ① in the direction of the arrow and lock; the upper limit on coarse adjustment movement is set at the locked position.

After changing a specimen, approximate refocusing is easily accomplished by rotating the coarse adjustment knob to reach the pre-focused position. After this, all you have to do is make fine adjustments with the fine adjustment knob.

⊙ Stage movement with the fine adjustment knob is not locked.

CAUTION When the pre-focusing lever is locked, a coarse movement stroke is reduced due to the microscope's mechanism, causing the stage not to be able to be lowered to the lower limit. To lower the stage to the lower limit, release the pre-focusing lever.

5-3 Stage

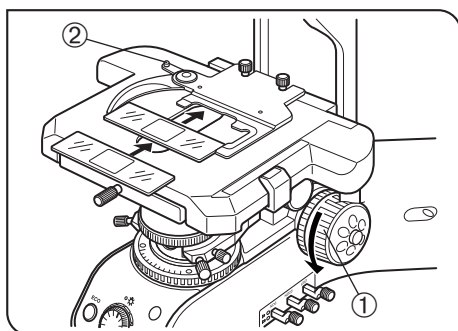

Fig. 27

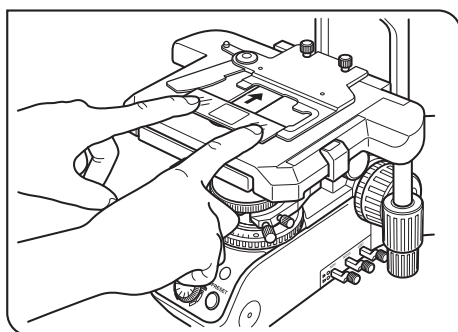

Fig. 28

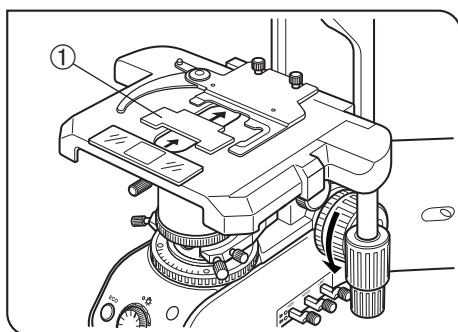

Fig. 29

1 Placing the Specimen (Figs. 27 & 28)

- ⊙ The dimensions of the slide glass should be 26 x 76 mm with thickness of 0.9 to 1.2 mm, and the cover glass should have thickness of 0.17 mm.
- ⊙ When observing very large specimens, remove the slide holder and place the specimen directly on the stage.
- ⊙ The maximum weight of an object such as a specimen to be placed on the stage is 0.8 kg (including the slide holder).
- ⊙ When a non-Olympus stage is going to be attached, make sure that its weight does not exceed 4 kg.

Microscopy with Double-Slide Holder (Fig. 27)

1. Turn the coarse adjustment knob ① to lower the stage.
2. Open the spring-loaded curved finger ② on the slide holder and place one or two specimen slides on the stage from the front.
3. After placing the slides as far as they will go, gently release the curved finger.

Microscopy with Single-Slide Holder (Fig. 28)

The specimen side can easily be placed by sliding it into the slide holder from the front.

Examining a whole specimen

Use one of the thin slide holders listed below that cause less interference with the objectives*:

- U-HRD-4 • U-HLD-4 • U-HLS-4

* The applicable objectives are ones with 40X or less magnification (except Apo series).

Using an Oil Immersion Condenser

Use the optional U-SVRO (right-hand knob) or U-SVLO (left-hand knob) slotted stage which prevents close contact between the specimen and stage.

2 Using the Auxiliary Slide Holder (Fig. 29)

Applicable revolving nosepieces: U-D7RE, U-D7RES, U-P6RE, U-D6BDRE, U-P5BDRE

- ⊙ When a biological slide glass specimen is placed on the U-HLDT4/U-HRDT4 two-slide holder (thick type), the slide holder may interfere with the objective when the following conditions are combined;
 - The objective in use has a short WD (Working Distance);
 - The specimen being observed is the specimen placed on the rear side of the slide holder, and;
 - The stage is in a rotated position.

If the slide holder contacts the objective, set the provided auxiliary slide holder ① as shown in the figure and observe only the specimen on the front side of the slide holder.

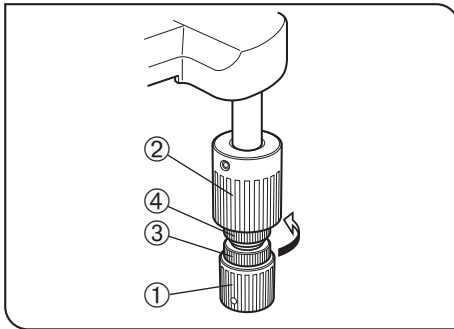

Fig. 30

3 Adjusting the X- and Y-Axis Knob Tension (Fig. 30)

1. Hold the X-axis knob ① and slide up the Y-axis knob ② up to expose the adjustment knobs.
2. Turning the X-axis adjustment knob ③ or Y-axis adjustment knob ④ clockwise (in the direction of the arrow) increases the tension and counterclockwise decreases it.

CAUTION

If the tension is adjusted to tight, a creaking sound may be heard during stage travel, and the stage stopping accuracy may be imperiled.

- ⊙ After long hours of use, the stage guide may be deviated and the stage travel range may be decreased.
- ⊙ However, this is not malfunction and can be corrected easily as described below.

[Treatment]

Horizontal direction: Hold the specimen holder and move the stage guide to the left and right so that it hits the stoppers.

Vertical direction: Hold the upper stage and move it to the front and rear so that it hits the stoppers.

Stage Feed Knob Rubber Caps (Optional)

- ⊙ When the X- and Y-axis knobs are fitted with the rubber caps, the knobs can be adjusted without slipping and fine adjustment is possible by holding the knobs with a very light force. The knob rubber caps also reduce fatigue after long hours of operation.

The U-SHGT thick type (thickness 5 mm) and U-SHG thin type (thickness 2 mm) knob rubbers are available.

To attach the knob rubbers:

First fit the larger knob rubber to the Y-axis (upper) knob from below it, then fit the smaller knob rubber to the X-axis (lower) knob from below it.

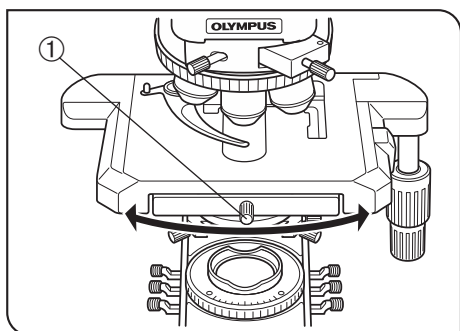

Fig. 31

4 Rotating the Stage (Fig. 31)

1. Slightly loosen the stage clamping screw ①.
2. The stage can be rotated both clockwise and counterclockwise by the stage clamping screw.

CAUTION A click may be heard and felt during rotation. However, this is due to the construction of the substage and does not indicate a malfunction.

Ⓞ The angle of rotation varies depending on the positions of the X- and Y-axis knobs.

	Angle of Rotation	
	Clockwise	Counterclockwise
Right hand knobs	239°	20°
Left hand knobs	20°	239°

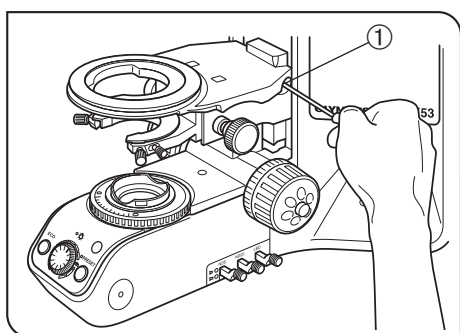

Fig. 32

5 Adjusting the Stage Height (Figs. 32 & 33)

Ⓞ By lowering the position of the substage, the microscope will accommodate specimens with maximum height of 35 mm. This is useful when observing metallurgical specimens and other thick objects.

- 1 Lower the stage to the lower limit, then remove the stage from the microscope.
- 2 Using the Allen screwdriver, loosen the substage bracket clamping screw ① and remove the substage.
- 3 Turn the coarse adjustment knob and raise the focusing block ③ to where the stopper screw ② on the arm becomes visible.
- 4 Using the Allen screwdriver, loosen and remove the upper stopper screw ②.
- 5 Reattach substage bracket and stage.

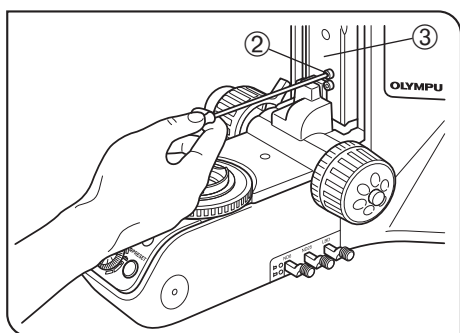

Fig. 33

5-4 Observation Tube

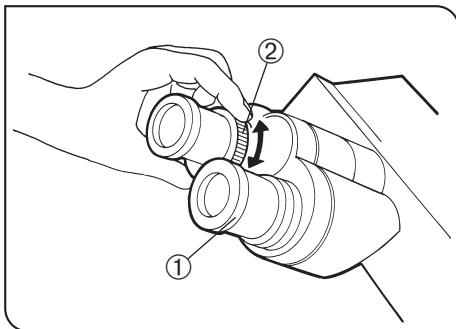

Fig. 34

1 Adjusting the Diopter

(Fig. 34)

1. Set the diopter adjustment rings on both sides to scale "0".
2. Engage a high-power objective (40X or so) in the light path, look into the right eyepiece with your right eye, and rotate the coarse and fine adjustment knobs to bring the specimen into focus.
 - ⊗ Do not use an immersion objective.
3. Engage a low-power objective (10X or so) in the light path, rotate the right diopter adjustment ring to bring the specimen into focus. Do not touch the coarse and fine adjustment knobs during the focusing.
4. Looking into the left eyepiece with your left eye, rotate the left diopter adjustment ring to bring the specimen into focus.
 - ⊗ The above procedure adjusts the diopter with reference to the right eye, but it is also possible to adjust with reference to the left eye. In this case, read the above procedure by inverting "right" and "left."
 - ⊗ If an eyepiece equipped with a diopter adjustment ring is inserted into the side equipped with another diopter adjustment ring of the observation tube, perform the above procedure without moving the diopter adjustment ring of the observation tube from the "0" position.

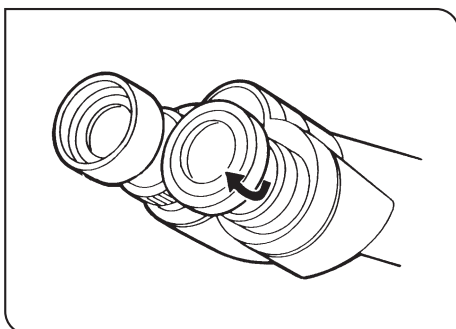

Fig. 35

2 Using the Eye Shades

(Fig. 35)

When Wearing Eyeglasses

Use with the eye shades in the normal, folded-down position. This will prevent the eyeglasses from being scratched.

When Not Wearing Eyeglasses

Extend the folded eye shades in the direction of the arrow to prevent extraneous light from entering between the eyepieces and eyes.

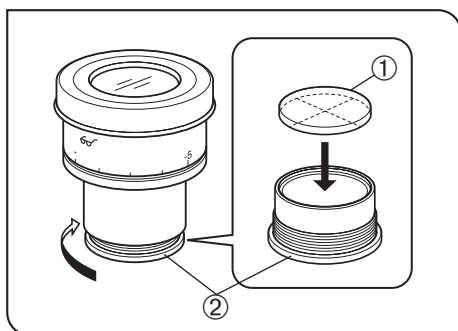

Fig. 36

3 Mounting the Eyepiece Micrometer Disk (Fig. 36)

When the WHN10X-H eyepieces are used, an eyepiece micrometer disk can be mounted.

Use 24 mm dia. x 1.5 mm thick micrometer disks.

Following Fig. 36, turn the built-in micrometer-mounting frame ② to the arrow direction to remove it from the eyepiece and place a micrometer disk ① into the mounting frame so that the surface with the model indication faces downward.

ⓄThe micrometer-mounting frame may be tight for certain micrometer disks.

In this case, turn the frame by holding the circumference with a light, uniform force or by applying the frame against a rubber sheet. Do not grasp the frame with a strong force, as this may deform the frame and make it harder to remove it.

Re-attach the micrometer mounting frame in the original position.

ⓄBe careful not to touch the lens surface with your finger.

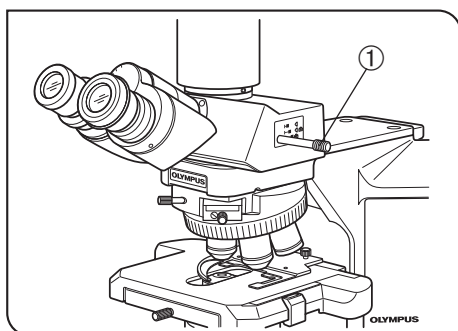

Fig. 37

4 Selecting the Light Path of the Trinocular Tube (Fig. 37)

Slide the light path selector knob ① to select the desired light path.

Trinocular tube	Light path selector knob position		
	Pushed in	Middle position	Pulled out
U-TR30-2	100% for binocular eyepieces	20% for binocular eyepieces,	100% for camera
U-SWTR-3		80% for camera	
U-TR30NIR*		50% for binocular eyepieces, 50% for camera	
U-TTR-2**	50% for binocular eyepieces, 50% for camera	100% for binocular eyepieces	

*With the infrared trinocular tube, infrared observation up to 1000 nm is possible. For details, consult your Olympus representative.

**The light path selector knob is removable and can be attached to the other side.

1. Put the edge of a coin in the groove on the tip of the light path selector knob. Turn the coin clockwise to remove the knob.
2. Remove the cap from the other side.
3. Insert the end of the light selector knob into the hole from which the cap has been removed. Put the edge of a coin in the groove on the other end of the knob and turn the coin counterclockwise to attach the knob.
4. Close the open hole with the cap.

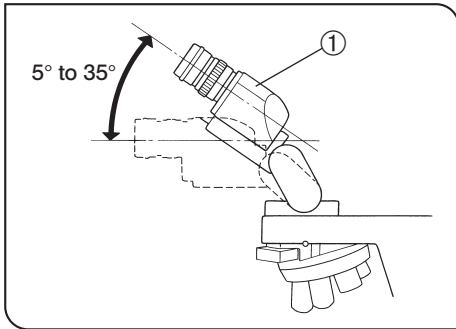

Fig. 38

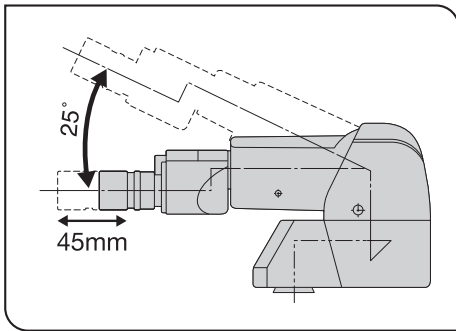

Fig. 39

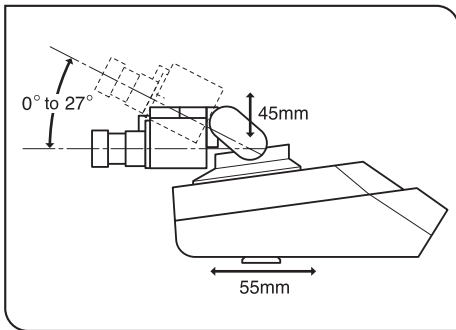

Fig. 40

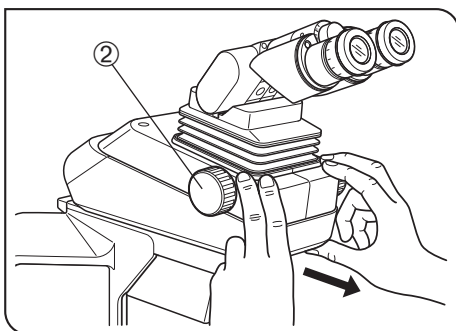

Fig. 41

5 Adjusting the Tilt

(Figs. 38 to 41)

Adjust the height and tilt of the observation tube to obtain the most comfortable viewing position.

U-TBI-3	5° to 35°
U-TBI-3-CLI	5° to 35°
U-ETBI	0° to 25°
U-TTBI	0° to 25°
U-TTR-2	5° to 35°
U-TTLBI	0° to 27°

With the U-TBI-3 (Fig. 38)

Holding the binocular section ① with both hands, raise or lower it to the desired position.

CAUTION

Never attempt to force the binocular section past the upper or lower stop position. Applying excessive force could destroy the limiting mechanism.

Ⓞ The U-TBI-3/U-TBI-3-CLI can be used in combination with only one intermediate attachment.

Ⓞ If you need photography using the U-TBI-3/U-TBI-3-CLI, use the U-TRU trinocular intermediate tube.

With the U-ETBI/U-TTBI (Fig. 39)

The U-ETBI and U-TTBI are ergonomic observation tubes with normal field, capable of the adjustments of the positioning angle (0° to 25°) as well as front-rear positioning (by 45 mm) of the eyepieces. The U-ETBI is the erect image model and the U-TTBI is the inverted image model, and both models are of the same size.

With the U-TTLBI (Fig. 40)

The U-TTLBI is a Tilting, Telescopic, Lifting binocular tube with the following adjustment capabilities.

- Eyepiece angle adjustment (0° to 27°)
- Eyepiece up-down position adjustment (45 mm)
- Observation tube front-rear position adjustment (55 mm)

Ⓞ When adjusting front-rear position of the observation tube, hold the base of the observation tube as shown in Fig. 41.

Ⓞ When storing the microscope, increase the angle of the eyepieces so as to prevent the eyepieces from dropping.

Ⓞ To adjust the up-down position of the eyepiece, turn the dial ②.

CAUTION

The intermediate attachments that can be combined with the U-TTBI and U-TTLBI are limited. For details, please contact Olympus.

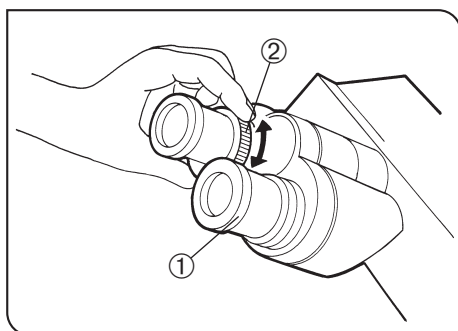

Fig. 42

6 Using Eyepieces Incorporating a Micrometer (Fig. 42)

ⓄWhen the eyepieces in use incorporate a micrometer, the accuracy of the left-right focusing adjustment (diopter adjustment) can be improved further.

1. Looking into the right eyepiece with your right eye, turn the top of the eyepiece ① so that the micrometer in the field of view looks sharpest (Fig. 42).
2. Looking into the right eyepiece, rotate the coarse and fine adjustment knobs to bring the specimen and micrometer (cross lines, etc.) into focus.
3. Looking into the left eyepiece with your left eye, rotate the diopter adjustment ring ② to bring the specimen into focus.

5-5 Condenser

For how to adjust the centering of the condenser, see page 12.

1 Compatibility of Objectives and Condensers

Objective Magnification	Condenser				
	Low magnification U-LC	Abbe U-AC2	Achromat/aplanat U-AAC	Swing-out U-SC3	Ultralow magnification U-ULC-2
1.25X	Applicable (FN 22)**	Applicable (FN 22)	Applicable (FN 26.5)	Applicable (FN 22)	Applicable (FN 26.5)
2X				Applicable (FN 26.5) by moving top lens out of the light path* (FN 26.5)	
4X		Applicable (FN 26.5)	Applicable (FN 26.5)	Engage top lens in light path (FN 26.5)	
10-60X					
100X					

* When using the U-SC3 swing-out condenser together with a 1.25X to 4X objective, fully open the condenser aperture iris diaphragm and use the field iris diaphragm in the base as aperture diaphragm. With the 1.25X to 2X objectives, the surroundings of the field of view may become dark.

ⓄTo obtain better illumination in camera recording using a 1.25X to 4X objective, use of the U-ULC-2 is recommended.

**When the U-LC is used with an objective with an NA of 1.0 or more, the NA of the lighting becomes insufficient.

ⓄWhen the U-LC is used, it is required to attach the auxiliary lens (page 35).

5-6 Immersion Objectives

CAUTION Be sure to use the provided Olympus Immersion oil.

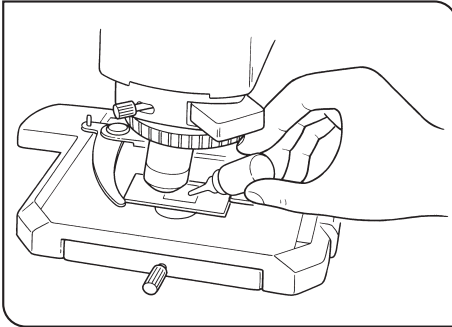

Fig. 43

1 Using Immersion Objectives

(Fig. 43)

1. Focus on the specimen with objectives in the order of lower-power to higher-power ones.
2. Before engaging the immersion objective, place a drop of provided immersion oil onto the specimen at the area to be observed.
3. Turn the revolving nosepiece to engage the immersion objective, then focus using the fine adjustment knob.

CAUTION Since air bubbles in the oil will affect the image quality, make sure that the oil is free of bubbles.

- a. To check for bubbles, remove the eyepiece and fully open the field and aperture iris diaphragms, then look at the exit pupil of the objective inside the observation tube. (The pupil should appear round and bright.)
 - b. To remove bubbles, turn the revolving nosepiece to repeatedly defocus and refocus the immersion objective.
- Ⓞ If the condenser engraving shows a numerical aperture (NA) of 1.0 or higher, the number applies only when oil is applied between the slide glass and the top surface of the condenser. When oil is not present, the NA is about 0.9.
4. After use, remove immersion oil from the objective front lens by wiping with gauze slightly moistened with absolute alcohol.

CAUTION **Caution in use of immersion oil**

If immersion oil enters your eyes or contacts with your skin, immediately take the following treatment.

Eyes: Rinse with fresh water (for 15 minutes or more).

Skin: Rinse with water and soap.

If the appearance of the eyes or skin is altered or pain persists, immediately see your doctor.

5-7 Objectives with Correction Collar

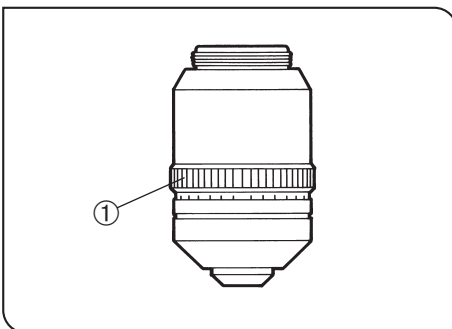

Fig. 44

Ⓞ If the thickness scale setting of the objective with collection collar does not match the cover glass thickness, the objective cannot manifest the full performance. To prevent this, be sure to perform the following adjustment when using an objective with collection collar.

Adjustment Procedure

- If the cover glass thickness is known, set the correction collar ① to that scale value. (Fig. 44)
 - If the cover glass thickness is unknown, adjust the correction collar ① and fine adjustment knob alternately until the positioning with the highest contrast is obtained.
- Ⓞ Be careful not to touch the correction collar ① when turning the revolving nosepiece.

6 CAMERA RECORDING

- ⊙ Use a trinocular observation tube such as the U-TR30-2 or U-SWTR-2 when shooting the video or digital camera picture of the microscope images.
The trinocular tube accepts a camera adapter (certain TV adapters necessitate a camera mount adapter).
For details, refer to the instruction manuals for these accessories.
- ⊙ Be sure to adjust the parfocality before using a camera adapter. Otherwise, the focusing of the camera image will not match that of the image observed through eyepieces. For the parfocality adjustment method, refer to the instruction manual for the camera adapter in use.

1 System Chart

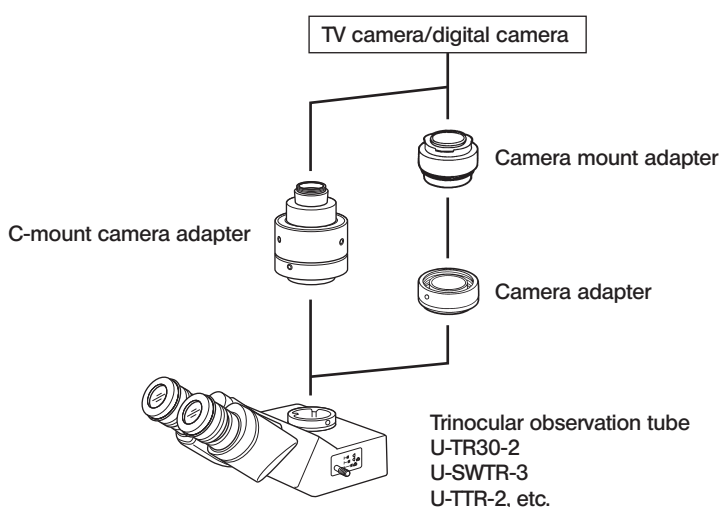

2 Selecting the Camera Adapter Magnification

The image pickup area is determined by the size of the image sensor used in the TV camera or digital camera and the magnification of the camera adapter.

The following illustrations show the image pickup areas of camera adapters when the SWH10X-H eyepieces with a FN of 26.5 are used (the FN of the WHN10X eyepieces is 22).

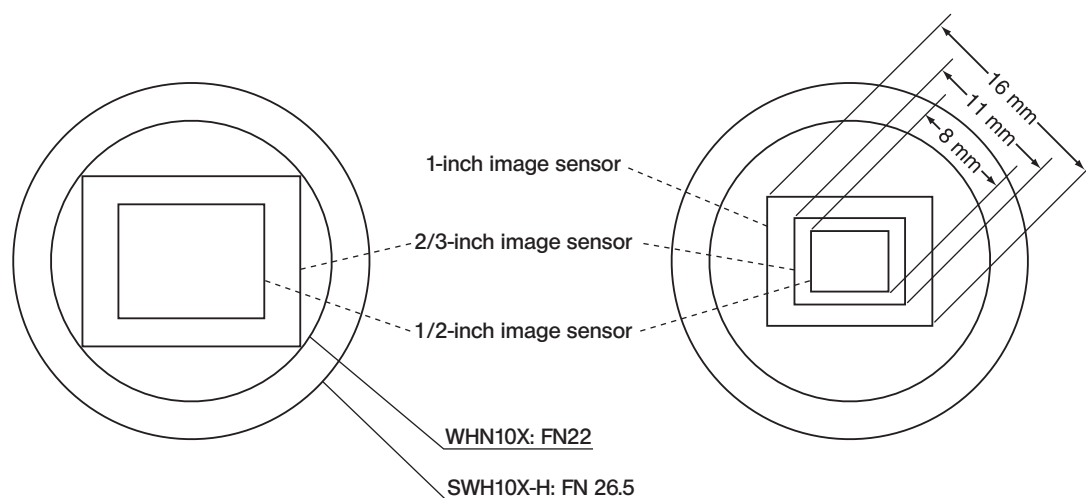



When a 0.5X camera adapter is used

When a 1X camera adapter is used

7 TROUBLESHOOTING GUIDE

Under certain conditions, performance of the unit may be adversely affected by factors other than defects. If problems occur, please review the following list and take remedial action as needed. If you cannot solve the problem after checking the entire list, please contact your local Olympus representative for assistance.

Problem	Cause	Remedy	Page
1. Observation/illumination System			
a) Bulb does not light.	Bulb is burned out.	Replace the bulb. Note that, even when the filament looks normal, there may be a wire disconnection in the terminal section.	35
	Power cord is unplugged.	Plug power cord into the power outlet.	37
b) Bulb is not lit.	It has been turned OFF due to the operation of the ECO mode.	Set the main switch to OFF then ON again or press the ECO/NORMAL switch twice.	14
c) Bulb operates, but field of view remains dark.	Aperture and field iris diaphragms are not opened wide enough.	Adjust them to proper sizes.	12
	Condenser is lowered too much.	Adjust the condenser height position.	12
	Light path selector knob is set to the  position.	Move the knob to the  or  position.	23
d) Field of view is obscured or not evenly illuminated.	Light path selector knob is in an intermediate position.	Set the knob according to the observation method.	23
	Revolving nosepiece is not correctly engaged.	Make sure that the revolving nosepiece clicks properly into place.	-
	Condenser is not attached properly.	Re-attach it.	36
	Revolving nosepiece is not attached properly.	Push the side dovetail all the way until it is stopped.	36
	An objective that falls outside of the condenser's illumination range is used.	Use a condenser to match the purpose.	25
	Condenser is not properly centered.	Center the condenser.	12
	Field iris diaphragm is stopped down too far.	Open the field iris diaphragm until an optimum size.	12
	Bulb is not mounted correctly.	Push the pins of halogen bulb all the way until the stop position.	35
e) Dirt or dust is visible in the field of view.	Dirt/dust on the eyepiece.	Clean thoroughly.	3
	Dirt or the to surface of the condenser.		
	Dirt/dust on the specimen.		
f) Visibility is poor. • Image is not poor. • Contrast is poor. • Details are indistinct. • Image glares.	A non-UIS2/UIS objective is used.	Use only UIS2/UIS series objectives with this microscope.	33
	Condenser is lowered too far.	Adjust the condenser height position.	12
	Aperture iris diaphragm is stopped down too far.	Open the aperture iris diaphragm to an optimum size.	12
	Revolving nosepiece is not mounted properly.	Push the slide dovetail all the way until it is stopped.	-
	Correction collar on correction collar equipped objective is not properly adjusted.	While focusing, turn the correction collar to find the position with the best contrast.	26
	Front lens of objective is dirty.	Clean objective.	3
	Immersion oil is not being used with an oil immersion objective.	Use immersion oil.	26

Problem	Cause	Remedy	Page
f) Visibility is poor. • Image is not poor. • Contrast is poor. • Details are indistinct. • Image glares.	Immersion oil contains bubbles.	Remove the bubbles.	26
	Recommended immersion oil is not used.	Use the Olympus-designated immersion oil.	26
	Dirt/dust on specimen.	Clean it.	3
	Dirt/dust on condenser.		
	Inappropriate object side or cover glass thickness.	Replace with glass of recommended thickness.	19
g) One side of image is blurred.	Objective is not correctly engaged in light path.	Make sure that revolving nosepiece clicks into place correctly.	-
	Revolving nosepiece is not correctly mounted.	Push slide dovetail all the way until it is stopped.	36
	Stage is not correctly mounted.	Re-attach it.	21
	Specimen is not correctly mounted on stage.	Place specimen correctly on top of stage and secure it with slide holder.	19
h) Image appears to waver.	Revolving nosepiece is not corrected mounted.	Push slide dovetail all the way until it is stopped.	21
	Objective is not correctly engaged in light path.	Make sure that revolving nosepiece clicks into place correctly.	-
	Condenser is not properly centered.	Center the condenser.	12
i) Field of view becomes only slightly brighter when the brightness adjustment knob is rotated.	Condenser is not properly centered.	Center the condenser.	12
	Condenser is lowered too far.	Adjust the condenser height position	12
j) Image looks reddish.	The LBD filter is not engaged in the light path.	Engage the LBD filter in the light path.	10
2. Electrical System			
a) Bulb intermittently lights and goes out.	Bulb is nearly burned out.	Replace bulb.	35
	A connector is not properly connected.	Check all connectors.	-
b) Bulb burns out almost immediately.	Wrong type of bulb is being used.	Use correct bulb type.	35
c) Brightness does not change when you turn light intensity adjustment knob.	Light intensity preset button is set to ON.	Press button to OFF.	13
d) Lamp voltage cannot be varied with light intensity adjustment knob.	Bulb is burned out.	Replace bulb.	35
3. Coarse/Fine Adjustment			
a) Coarse adjustment knob is hard to turn.	Tension adjustment ring is tightened excessively.	Loose ring.	18
	You are trying to raise stage without coarse adjustment knob while pre-focusing lever is kept locked.	Unlock pre-focusing lever.	18
b) Stage drifts down by itself or focus is lost during observation.	Tension adjustment ring is too loose.	Tighten ring.	18
c) Image cannot be focused.	When adjusting stage height, you forgot to reattach upper stopper screw.	Reattach upper stopper screw.	21
d) Coarse adjustment will not go all the way up.	Pre-focusing lever is locked at a too low height.	Unlock pre-focusing lever.	18

Problem	Cause	Remedy	Page
e) Coarse adjustment will not go all the way down.	Condenser holder is too low.	Raise condenser holder.	12
f) Objective makes contact with specimen before focus is obtained.	Specimen is mounted upside down.	Mount specimen correctly.	-
4. Observation Tube			
a) Field of view of one eye does not match that of the other.	Interpupillary distance is incorrect.	Adjust interpupillary distance.	11
	Incorrect diopter adjustment.	Adjust diopter.	22
	Different eyepieces are used on left and right.	Change on eyepiece to match the other so that both sides are the same type.	-
	Your view is not accustomed to microscope observation.	Upon looking into eyepieces, try looking at overall field before concentrating on specimen range. You may also find it helpful to look up and into distance for a moment before looking back into microscope.	-
5. Stage			
a) Image shifts when you touch stage.	Stage is not properly mounted.	Clamp stage.	21
b) Specimen stops midway on the X-axis traverse.	Specimen is not correctly positioned.	Place specimen correctly.	19
c) Horizontal and/or X- and Y-axis knobs are too tight or too loose.	Tension of horizontal and/or X- and Y-axis knobs is too high or too low.	Adjust tension.	20
d) Stroke has reduced.	Stage guide is deviated.	Use treatment method described on page 20.	20

8 SPECIFICATIONS

Item	Specification						
1. Optical system	UIS2/UIS (Universal Infinity System) optical system (featuring infinity correction)						
2. Illumination	Built-in transmitted Koehler illumination FN (Field Number): 26.5 (super-widefield compatible) 12V, 100W long-life halogen bulb (pre-centered) 12V100WHAL-L (PHILIPS 7724) (Average life time: Approximately 2,000 hr. when used as directed) Light intensity voltage range: 2 V or less to 12.0 V (continuous) Light intensity preset button (voltage adjustment range: 2 V or less to 12.0 V) Rated voltage: 100-120/220-240 V ~, 1.7/0.8 A, 50/60 Hz Power consumption: 140 W						
3. Focusing	Stage height movement by roller guide (rack & pinion) Stroke per rotation: 0.1 mm (fine), 178 mm (coarse) Full stroke range: 25 mm Upper limit stopper Tension adjustment on coarse focus adjustment knob						
4. Revolving nosepiece	Type	U-5RE-2	U-D6RE	U-P6RE	U-D7RES		
		5-position revolving nosepiece	Universal 6-position revolving nosepiece	Universal 6-position centered revolving nosepiece	Coded 7 position nosepiece		
	Installable modules	None		Transmitted DIC prism, transmitted light analyzer			
5. Observation tube	Type	U-BI30-2	U-BI-3/ U-TBI-3-CLJ	U-TR30-2	U-TR30NIR	U-TTR-2	U-SWTR-3
		Widefield binocular tube	Widefield tilting binocular	Widefield trinocular tube	Widefield tilting trinocular tube	Super wide-field trinocular	
	Field No.	22					26.5
	Tube inclination	30°	5°-35° continuous	30°	5°-35° continuous	30°	
	Interpupillary distance adjustment	50 mm to 76 mm					
	Light path selector	None			3 steps: ① BI 100% ② BI 20%, Camera 80% (BI 50%, Camera 50% for U-TR30NIR and U-TTR-2) ③ Camera 100%		
6. Stage	Type	U-SVRB-4			U-SVLB-4		
		Common-axis knobs on bottom right			Common-axis knobs on bottom left		
		Rectangular ceramic-coated, wire-driven stage					
	Size	156 mm (D) x 191 mm (W)					
	Movement mechanism	X- and Y-axis knobs with adjustable tension Movement range: 52 mm in vertical (Y) direction, 76 mm in horizontal (X) direction					
	Specimen holders (single slide holder)	U-HLST-4 (thick slide holder) U-HLS-4 (thin slide holder)					
	Specimen holders (double slide holder)	U-HLDT-4 (left opening, thick slide holder) U-HLD-4 (left opening, thin slide holder)			U-HRDT-4 (right opening, thick slide holder) U-HRD-4 (right opening, thin slide holder)		

Item	Specification				
7. Condenser	Type	U-LC	U-AC2	U-SC3	U-AAC
		Low magnification	Abbe	Swing-out	Achromat/ Aplanat
	N.A.	0.75	1.10	0.9 - 0.1	1.40
	Aperture iris diaphragm	With numerical aperture scale			
	Objective range	2X - 60X (for FN 26.5 widefield)	4X (for FN 22 widefield), 10X - 100X (for FN 26.5 super widefield)	1.25X (for FN 22 widefield), 2X - 100X (for FN 26.5 super widefield)	10X - 100X (for FN 26.5 super widefield)
8. Operating environment	<ul style="list-style-type: none"> • Indoor use • Altitude: Max. 2000 meters • Ambient temperature: 5° to 40°C (41° to 104° F) • Maximum relative humidity: 80% for temperatures up to 31°C (88°F), decreasing linearly through 70% at 34°C (93°F), 60% at 37°C (99°F), to 50% relative humidity at 40°C (104°F) • Supply voltage fluctuations; Not to exceed ±10% of the normal voltage • Pollution degree: 2 (in accordance with IEC60664-1) • Installation/Overvoltage category: II (in accordance with IEC60664-1) 				
9. Storage environment	Temperature: Min. -25°C, Max. 65°C Humidity: Min. 0%, Max. 95%				

9 OPTICAL CHARACTERISTICS (UIS2 Series)

— UIS series objectives not listed here can also be combined with this microscope. —

The following table shows the optical characteristics of combinations of eyepieces and objectives. The figure on the right shows the performance data engraved on the objectives.

NOTE

Refer to the latest catalogue or consult your local Olympus representative for the updated information on the eyepieces and objectives that can be combined with this microscope.

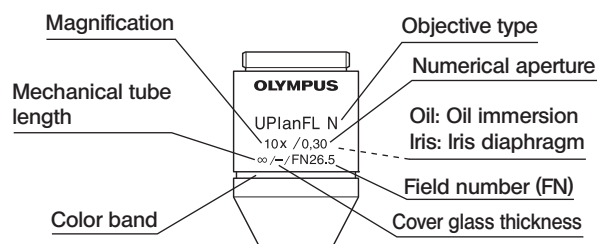

Optical character		Magnification	N.A.	W.D. (mm)	Cover glass thickness (mm)	Resolution (μm)	Eyepiece WHN10X (FN22)			Remark	
Objective Series	Marking						Total mag.	Depth of focus (μm)	Field of view		
PLN (PH) Plan Achromat (FN 22)	PlanN (Ph)	2X	0.06	5.8	-	5.59	20X	560.1	11.0		
		4X	0.1	18.5	-	3.36	40X	175.0	5.5		
		10X (Ph)	0.25	10.6	-	1.34	100X	28.0	2.2		
		20X (Ph)	0.4	1.2	0.17	0.84	200X	9.27	1.1		
		40X (Ph)	0.65	0.6	0.17	0.52	400X	3.04	0.55		
		50XOI	0.5-0.9	0.2	0.17	0.37	500X	1.7	0.44	Oil immersion/Iris	
PH: Phase contrast	100XO (Ph)	1.25	0.15	0.15	-	0.27	1000X	0.69	0.22	Oil immersion	
UPLFLN (PH) Plan Semi Apochromat (FN 26.5)	UPlanFLN (Ph)	4X	0.13	17.0	-	2.58	40X	127.2	5.5		
		10X2 (Ph)	0.3	10.0	-	1.12	100X	22.4	2.2		
		20X (Ph)	0.5	2.1	0.17	0.67	200X	7.0	1.1		
		40X (Ph)	0.75	0.51	0.17	0.45	400X	2.52	0.55		
		40XO	1.3	0.2	0.17	0.26	400X	1.27	0.55	Oil immersion	
		60X	0.9	0.2	0.17	0.37	600X	1.5	0.37	Correction collar	
		60XOI (Ph)	0.65-1.25	0.12	0.17	0.27	600X	0.98	0.37	Oil immersion/Iris	
		PH: Phase contrast	100XO2 (Ph)	1.30	0.2	0.17	0.26	1000X	0.66	0.22	Oil immersion
		100XOI2	0.6-1.30	0.2	0.17	0.26	1000X	0.66	0.22	Oil immersion/Iris	
UPLSAPO Plan Apochromat (FN 26.5)	UPlanSApo	4X	0.16	13.0	-	2.10	40X	99.6	5.5		
		10X2	0.4	3.1	0.17	0.84	100X	15.9	2.2		
		20X	0.75	0.6	0.17	0.45	200X	4.29	1.1		
		20XO	0.85	0.17	-	0.39	200X	3.5	1.1	Oil immersion	
		30XS	1.05	0.8	0.13-0.19	0.32	300X	2.07	0.73	Silicone immersion	
		40X2	0.95	0.18	0.17	0.35	400X	1.9	0.55	Correction collar	
		60XW	1.2	0.28	0.17	0.28	600X	1.03	0.37	Water immersion	
		60XO	1.35	0.15	0.17	0.25	600X	0.89	0.37	Oil immersion	
		60XS	1.3	0.3	0.15-0.19	0.26	600X	0.93	0.37	Silicone immersion	
		100XO	1.4	0.13	0.17	0.24	1000X	0.59	0.22	Oil immersion	
PLAPON Plan Apochromat (FN 26.5)	PlanApoN	1.25X	0.04	5.0	-	8.39	12.5X	1326.8	176		
		2X	0.08	6.2	-	4.19	20X	398.3	11.0		
		60XO	1.42	0.15	0.17	0.24	600X	0.83	0.37	Oil immersion	
MPLFLN Plan Semi Apochromat (FN 26.5)	MPlanFLN	40X	0.75	0.63	0	0.45	400X	1.7	0.55		
UApoN Apochromat (FN 22)	UApoN	20XW340	0.7	0.35	0.17	0.48	200X	4.08	1.1	Water immersion	
		40XW340	1.15	0.25	0.13-0.25	0.29	400X	1.29	0.55	Water immersion/ Correction collar	
		40XO340	1.35	0.1	0.17	0.25	400X	1.2	0.55	Oil immersion	

10 ASSEMBLY



10-1 Assembly Diagram

The diagram below shows the sequence of assembly of the various modules. The numbers indicate the order of assembly.

Assembly steps enclosed in **■** will be detailed on the subsequent pages.

The module numbers shown in the following diagram are merely the typical examples. For the modules with which the module numbers are not given, please consult your Olympus representative or the catalogues.

CAUTION When assembling the microscope, make sure that all parts are free of dust and dirt, and avoid scratching any parts or touching glass surfaces.

Ⓞ Most assembly operations are possible by using the Allen screwdriver () provided with the microscope. However, the assembly of the reflected light illuminator requires the use of the provided Allen wrench () for clamping the internal screws (to ensure the performance, we recommend that you have your Olympus representative assemble or remove this module).

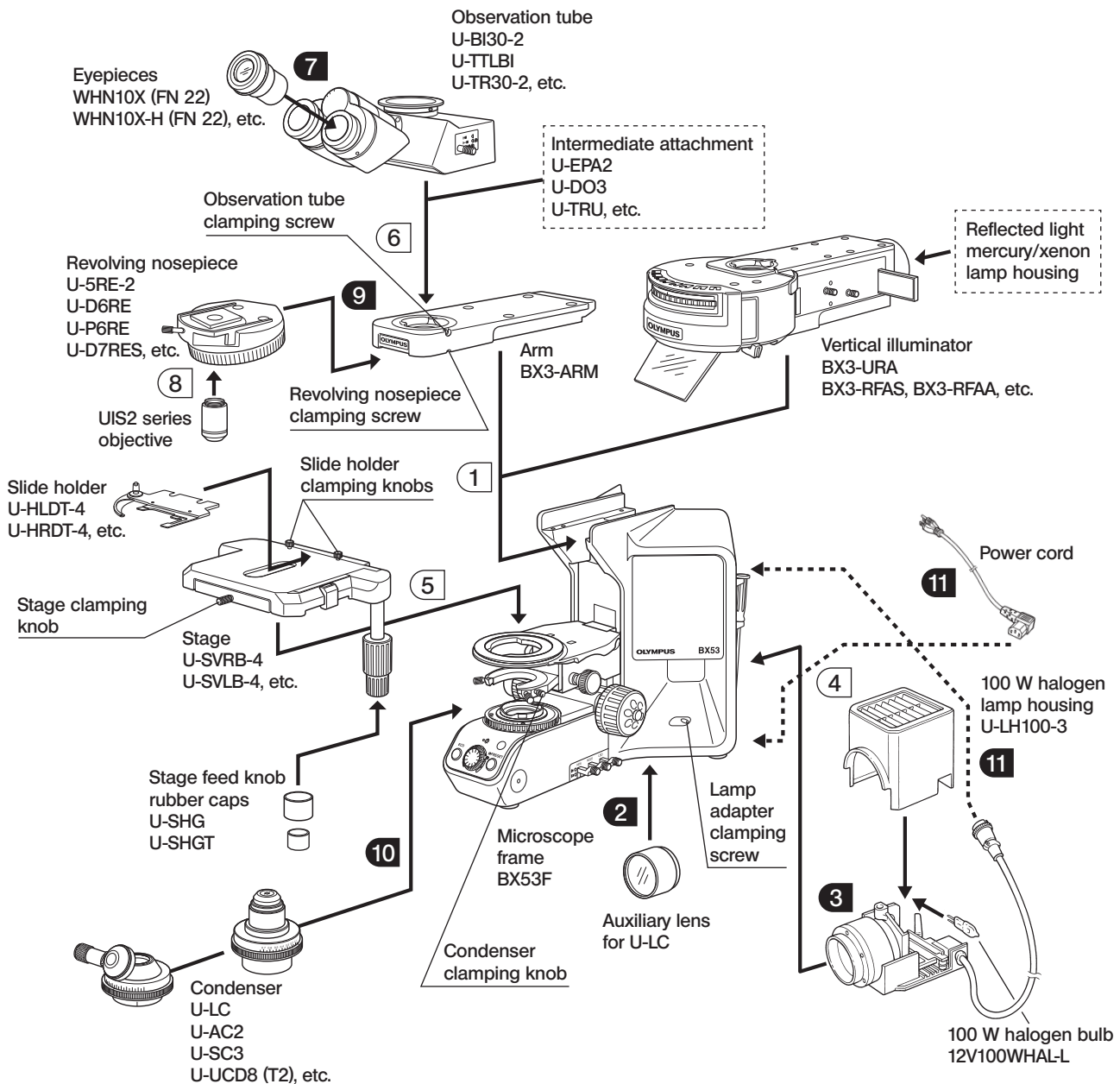

10-2 Detailed Assembly Procedures

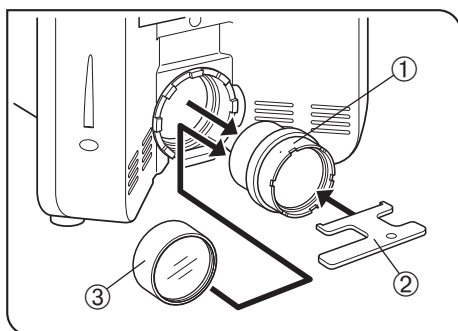

Fig. 45

2 Attaching the Auxiliary Lens for the U-LC Condenser (Fig. 45)

Ⓞ When a condenser other than the U-LC is to be used, remove the auxiliary lens.

Attach the auxiliary lens only when the U-LC is to be used.

1. Fit the mounting tool ② (provided with the U-LC) into the groove on the lamp adapter ① on the rear of the microscope, and turn the tool counterclockwise to remove the lamp adapter.
2. Screw the auxiliary lens ③ (provided with the U-LC) into the tip of the lamp adapter.
3. Attach the lamp adapter with the auxiliary lens to the original position, and clamp the lens by fitting and turning the mounting tool clockwise.

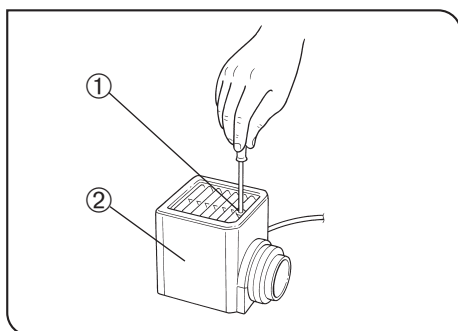
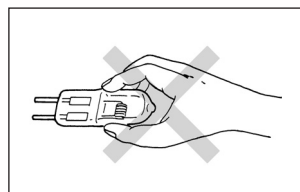

Fig. 46

3 Installing the Bulb (Figs. 46 to 48)

Ⓞ Use only the designated bulb 12V100W/HA-L (PHILIPS 7724).

1. Fully loosen the lamp housing clamping screw ① on top of the lamp housing cover with the provided Allen screwdriver.
2. Lift the lamp housing cover ② upward to remove it.
3. Turn the lamp socket ③ by 90° in the direction indicated by the arrow.
4. Holding the bulb ⑤ with gloves or a piece of gauze, depress the bulb clamping lever ④ and insert the bulb pins ⑥ fully into the pin holes ⑦ on the lamp socket. Gently release the bulb clamping lever to the original position to secure the bulb.



CAUTION To prevent reduced bulb life or cracking, do not touch the bulb with bare hands. If fingerprints are accidentally left on the bulb, wipe the bulb with a soft cloth.

5. Slide the lamp housing cover onto the housing base from the above. Tighten the clamping screw ① while pressing downward on the cover. (Fig. 46)

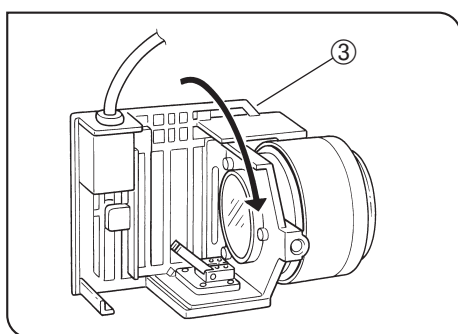

Fig. 47

CAUTION Caution for Bulb Replacement During Use or Right After Use

The bulb and the lamp socket are areas near these will be extremely hot during and right after use.

Set the main switch to "O" (OFF), disconnect the power cord from the wall outlet, then allow the old bulb and lamp housing to cool before replacing the bulb with a new of the designated type.

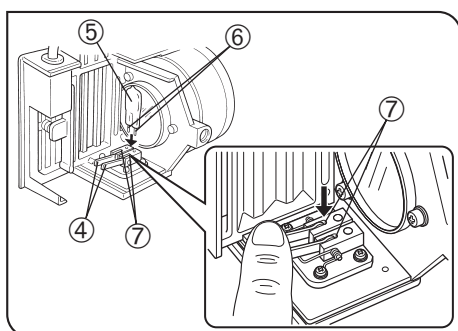

Fig. 48

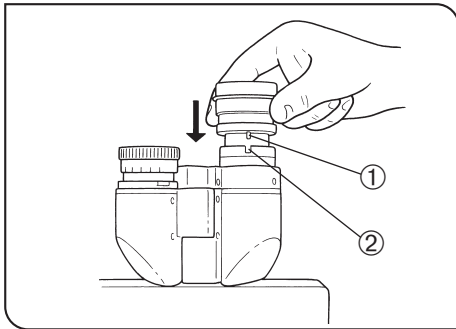

Fig. 49

7 Attaching the Eyepieces

(Fig. 49)

Gently insert the eyepieces all the way into the eyepiece sleeves.

CAUTION

- When using the U-BI30-2 binocular tube, eyepieces with a positioning pin cannot be attached because the U-BI30-2 does not have the positioning notch.
- When using an eyepiece with micrometer, attach it to the right-hand eyepiece sleeve.

When doing so, make sure that the eyepiece positioning pin ① fits into the notch ② on the eyepiece sleeve.

- The super-widefield trinocular observation tube is equipped with a positioning notch on both the left and right eyepiece sleeves. Make sure that the positioning pins on both eyepieces fits into the respective notches.

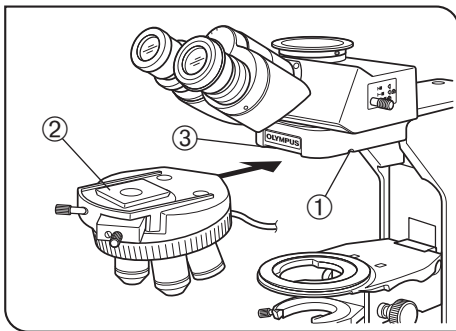

Fig. 50

9 Attaching the Revolving Nosepiece

(Fig. 50)

1. Rotate the coarse adjustment knob to lower the stage.
2. Loosen the revolving nosepiece clamping screw ① slightly. Do not loosen it too much because doing so makes it impossible to attach the revolving nosepiece.
3. Hold the revolving nosepiece so that the mount dovetail ② is horizontal and insert it all the way into the dovetail groove of the microscope arm ③.
4. Tighten the revolving nosepiece clamping screw ①.

Ⓞ When using the U-D7RES revolving nosepiece, distribute its cable toward the rear panel by passing it below the arm, and connect the cable to the connector of the U-CBS control box.

Ⓞ When using the U-D7REA revolving nosepiece, distribute its cable toward the rear panel by passing it below the arm, and connect the cable to the connector of the U-CBM control box.

Ⓞ When attaching or detaching a revolving nosepiece with a cable, be sure to disconnect the cable from the revolving nosepiece in advance.

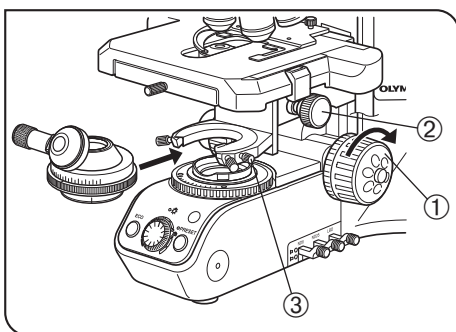

Fig. 51

10 Attaching the Condenser

(Fig. 51)

1. Turn the coarse adjustment knob ① to raise the stage to its upper limit.
2. Turn the condenser height adjustment knob ② to lower the condenser holder to its lowest position.
3. Fully loosen the condenser clamping knob ③.
4. Position the condenser so that the aperture scale is located in front. Gently slide the condenser along the dovetail all the way until it is stopped.

CAUTION

- When attaching a swing-out condenser with a positioning pin at the back such as the U-SC3, attach by aligning the positioning pin with the groove in the condenser sleeve.
- When attaching a condenser with swing-out top lens, swing out the top lens out of the way before inserting the condenser.

5. Tighten the condenser clamping knob and gently raise the condenser holder to its highest position.

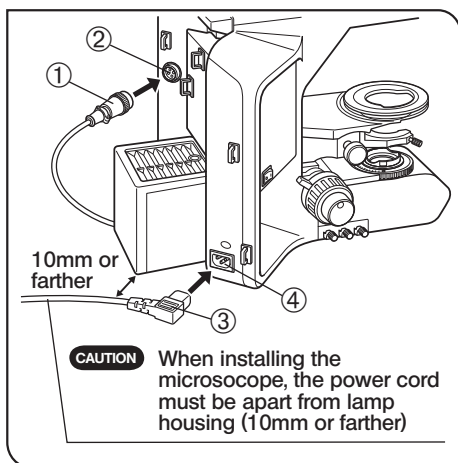

Fig. 52

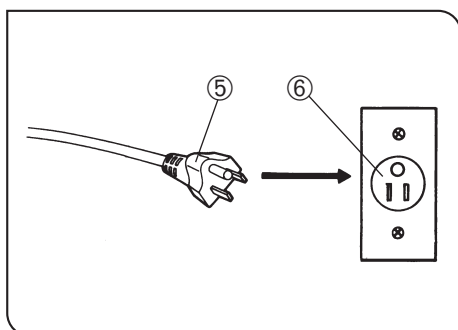

Fig. 53

11 Attaching the Lamp Housing Cable and Power Cord (Figs. 52 & 53)

- CAUTION**
- Cables and cords are vulnerable when bent or twisted. Never subject them to excessive force.
 - Make sure that the main switch is set to “O” (OFF) before connecting the power cord.

1. Connect the lamp housing cable connector ① into the connector ② on the rear of the microscope.

- CAUTION** Always use the power cord provided by Olympus. If no power cord is provided with the microscope, please select the proper power cord by referring to section “PROPER SELECTION OF THE POWER SUPPLY CORD” at the end of this instruction manual.

2. Connect the power cord plug ③ to the AC receptacle ④.

- CAUTION** The power cord should be connected to a grounded/earthed, 3-conductor power outlet. If the power outlet is not grounded/earthed properly, Olympus can no longer warrant the electrical safety performance of the equipment.

3. Plug the power cord plug ⑤ into the wall outlet ⑥.

- CAUTION** Should the power cord come in contact with the hot lamp housing, the power cord could melt and cause electric shock. Be sure to route the power cord away from the lamp housing.

- We recommend performing “Preventive Inspections” periodically (every time you replace lamps and at least once every 6 months).
- The table below identifies the check items to be observed. Put (X) if not applicable or (✓) if applicable.
- If there are any check marks (✓) noted, immediately stop use of the product and seek service or replacement for the illumination device(s) for prevention.
- If you detect an abnormality other than that listed below with your illumination device or other Olympus product, request inspection from your Olympus distributor.

If you have any questions, please contact your Olympus distributor.

Check items	Check results (Date)			
	/	/	/	/
1. More than 8 years have passed since original purchase or exceeds 20,000 hours of use.				
2. Lamp does not light sometimes even through the power is on. (Except discharge burners*1)				
3. Light flickers when you move a lamp cable or illumination devices.				
4. Lamp cable is unusually hot to the touch.				
5. Burning or smoke odor.				
6. Light still flickers after new lamp replacement. (Except discharge burners*1)				
7. Signs of deformation, backlash, or looseness, etc. when you assemble/ disassemble the illumination device. (i.e. it is hard to open/ close the lid during lamp-replacement.)				
8. Connection terminals or a lamp installation terminal have become discolored or tarnished on the right or left side. (Except discharge burners*1)				
9. Illumination device/ housing has become deformed, cracked or tarnished in any way.				
10. Lamp cables or wiring parts have become deformed, cracked or tarnished in any way.				
11. Frequent repairs to similar devices put into use at the same time as the unit being checked.				

If the spaces are not enough for check, copy this sheet.

*1 Discharge burners: Mercury burner / xenon burner / metal halide burner

■ PROPER SELECTION OF THE POWER SUPPLY CORD

If no power supply cord is provided, please select the proper power supply cord for the equipment by referring to “Specifications” and “Certified Cord” below:

CAUTION: In case you use a non-approved power supply cord for Olympus products, Olympus can no longer warrant the electrical safety of the equipment.

Specifications

Voltage Rating	125V AC (for 100-120V AC area) or, 250V AC (for 220-240V AC area)
Current Rating	6A minimum
Temperature Rating	60°C minimum
Length	3.05 m maximum
Fittings Configuration	Grounding type attachment plug cap. Opposite terminates in molded-on IEC configuration appliance coupling.

Table 1 Certified Cord

A power supply cord should be certified by one of the agencies listed in Table 1, or comprised of cordage marked with an agency marking per Table 1 or marked per Table 2. The fittings are to be marked with at least one of agencies listed in Table 1. In case you are unable to buy locally in your country the power supply cord which is approved by one of the agencies mentioned in Table 1, please use replacements approved by any other equivalent and authorized agencies in your country.



















Country	Agency	Certification Mark	Country	Agency	Certification Mark
Argentina	IRAM		Italy	IMQ	
Australia	SAA		Japan	JET, JQA, TÜV, UL-APEX/MITI	
Austria	ÖVE		Netherlands	KEMA	
Belgium	CEBEC		Norway	NEMKO	
Canada	CSA		Spain	AEE	
Denmark	DEMKO		Sweden	SEMKO	
Finland	FEI		Switzerland	SEV	
France	UTE		United Kingdom	ASTA BSI	
Germany	VDE		U.S.A.	UL	
Ireland	NSAI				

Table 2 HAR Flexible Cord

APPROVAL ORGANIZATIONS AND CORDAGE HARMONIZATION MARKING METHODS

Approval Organization	Printed or Embossed Harmonization Marking (May be located on jacket or insulation of internal wiring)		Alternative Marking Utilizing Black-Red-Yellow Thread (Length of color section in mm)		
			Black	Red	Yellow
Comite Electrotechnique Belge (CEBEC)	CEBEC	<HAR>	10	30	10
Verband Deutscher Elektrotechniker (VDE) e.V. Prüstelle	<VDE>	<HAR>	30	10	10
Union Technique de l'Electricite' (UTE)	USE	<HAR>	30	10	30
Instituto Italiano del Marchio di Qualita' (IMQ)	IEMMEQU	<HAR>	10	30	50
British Approvals Service for Electric Cables (BASEC)	BASEC	<HAR>	10	10	30
N.V. KEMA	KEMA-KEUR	<HAR>	10	30	30
SEMKO AB Svenska Elektriska Materielkontrollanstalter	SEMKO	<HAR>	10	10	50
Osterreichischer Verband für Elektrotechnik (ÖVE)	<ÖVE>	<HAR>	30	10	50
Danmarks Elektriske Materialkontroll (DEMKO)	<DEMKO>	<HAR>	30	10	30
National Standards Authority of Ireland (NSAI)	<NSAI>	<HAR>	30	30	50
Norges Elektriske Materielkontroll (NEMKO)	NEMKO	<HAR>	10	10	70
Asociacion Electrotecnica Y Electronica Espanola (AEE)	<UNED>	<HAR>	30	10	70
Hellenic Organization for Standardization (ELOT)	ELOT	<HAR>	30	30	70
Instituto Portages da Qualidade (IPQ)	np	<HAR>	10	10	90
Schweizerischer Elektro Technischer Verein (SEV)	SEV	<HAR>	10	30	90
Elektriska Inspektoratet	SETI	<HAR>	10	30	90

Underwriters Laboratories Inc. (UL)
Canadian Standards Association (CSA)

SV, SVT, SJ or SJT, 3 X 18AWG
SV, SVT, SJ or SJT, 3 X 18AWG

MEMO

MEMO

OLYMPUS®

www.olympus-global.com

Manufactured by

 **OLYMPUS CORPORATION**

Shinjuku Monolith, 2-3-1 Nishi-Shinjuku, Shinjuku-ku, Tokyo 163-0914, Japan

Distributed by



OLYMPUS EUROPA SE & CO. KG

Wendenstrasse 14-18, 20097 Hamburg, Germany

OLYMPUS SCIENTIFIC SOLUTIONS AMERICAS CORP.

48 Woerd Avenue Waltham, MA 02453, U.S.A.

OLYMPUS SINGAPORE PTE LTD

491B River Valley Road, #12-01/04 Valley Point Office Tower, Singapore 248373

OLYMPUS AUSTRALIA PTY. LTD.

3 Acacia Place, Notting Hill VIC 3168, Australia

OLYMPUS LATIN AMERICA, INC.

5301 Blue Lagoon Drive, Suite 290 Miami, FL 33126, U.S.A.

OLYMPUS KOREA CO., LTD.

8F Olympus Tower, 446 Bongeunsa-ro, Gangnam-gu, Seoul, 06153 Korea

