

REMOTE VISUAL INSPECTION

# Inspect Farther, Faster

## IPLEX™ GAir Industrial Videoscope



**EVIDENT**

**IPLEX**



## Inspect Farther, Faster

Long-distance remote visual inspections are faster and more efficient with the IPLEX™ GAir videoscope. Thoughtfully designed to ease the challenges of long-distance inspections, the IPLEX GAir videoscope enables you to flexibly maneuver up to 30 meters (98 feet) through complex piping systems with multiple elbows and then examine your target with high-quality, wide-view images and bright LED illumination.



# Extend Your Reach

For long-distance remote visual inspections, reaching the target quickly with easy insertion ability, intuitive navigation, and simple operation are critical for efficiency. And when you reach the target, bright illumination is required to identify defects. To meet these challenges, the IPLEX™ GAir videoscope combines maneuverability and brightness at long distances.

## Know your location

The gravity sensor automatically rotates live images regardless of the scope's orientation, and the insertion length indicator enables you to track the insertion tube's position.

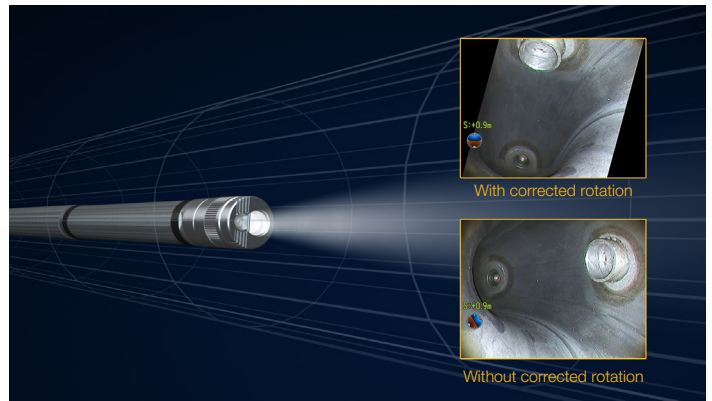

## Nimble through complex pipes

The uniquely designed scope guide head reduces friction and easily passes over joints between pipes while the universal push rod adaptor enables a smooth passage through pipes and elbows.

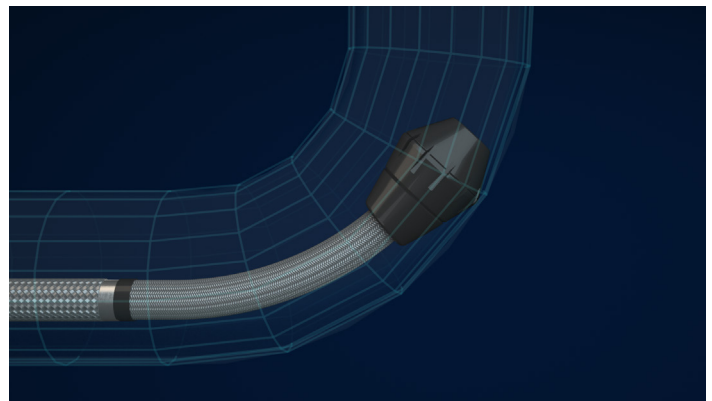

## Precise articulation regardless of length

Pneumatic articulation with an integrated air compressor delivers fine control, and the Tapered Flex™ insertion tube balances stiffness and flexibility for easy maneuvering.



When you arrive at your inspection target, the IPLEX GAir videoscope's LED illumination provides a consistent level of brightness regardless of the length. The level of brightness is also adjustable, so you can reduce it when moving through small-diameter pipes and increase it when working in large spaces.

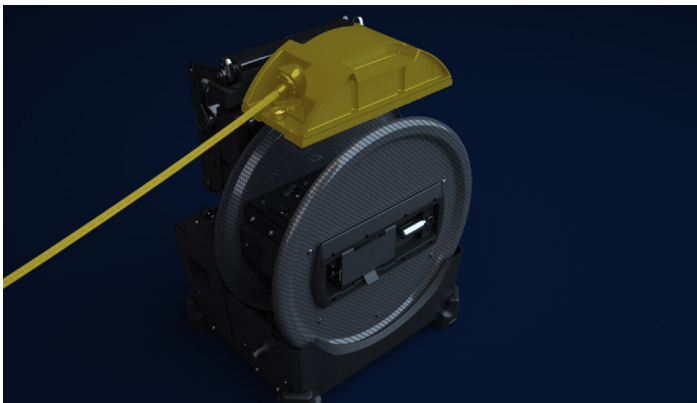

### Quickly change scopes

The waterproof interchangeable scope unit enables you to do quick swaps with no special tools.



### Comfortable viewing angle

Place the detachable LCD screen in an optimal position.

### Easy to transport

The compact, wheeled carrying case is easy to move—when you're ready to inspect, the wheels lock to keep the unit stationary.

# Faster Inspections

Built with the high-quality image sensor, brightness, and advanced image processing IPLEX™ videoscopes are known for, the IPLEX GAir videoscope provides clear wide-view images so that you can see more during your inspection.

When inspecting inside a pipe, the 220-degree fish-eye optical tip adaptor shows both the side wall and forward view at the same time. For added efficiency, the real-time image distortion correction has three modes to increase your probability of detection. These modes allow the videoscope to show distortion-corrected images with equivalent fields of view of 120, 180, and 220 degrees without changing the tip adaptor.

## Ultra-bright illumination

Powerful LEDs located in the distal end of the insertion tube light up large spaces without the intensity decay common to other long videoscopes.



## Long exposure

The long exposure mode enables a better probability of detection in very large spaces.

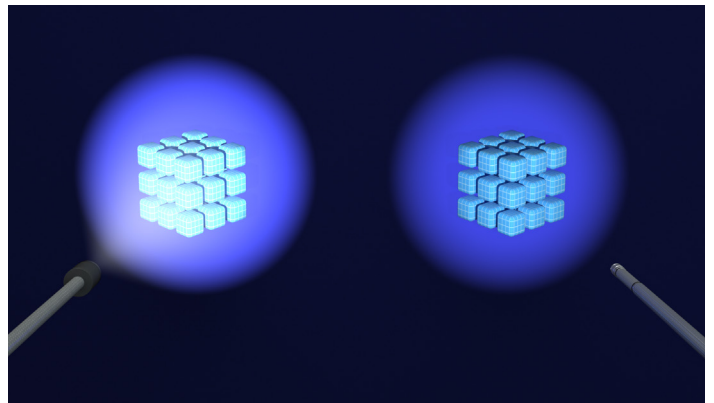

## Automatic brightness adjustments

The PulsarPic™ processor actively adjusts the illumination to consistently provide the right level of brightness.

## Efficient in oily environments

The oil-clearing tip adaptor draws oil away from the lens for clearer images and less time spent withdrawing the insertion tube to clean the lens.



# See Clearly from a Safer Distance

If you need to visually inspect dangerous or hazardous areas, such as inside a nuclear power plant, the IPLEX™ GAir videoscope helps you maintain a safer distance. Adding to the protection offered by its long 30 m (98 ft) scope, the videoscope unit can be controlled from up to 100 m (328 ft) away, so you can set it up in one area and control it from a different location.

## Functional from afar

The remote controller enables you to operate the videoscope's functions up to 100 m (328 ft) away, with optional transponder system.



## Alert from distance

The remote control vibrates to alert you of a situation that could damage your videoscope, such as removing the insertion tube while articulated.

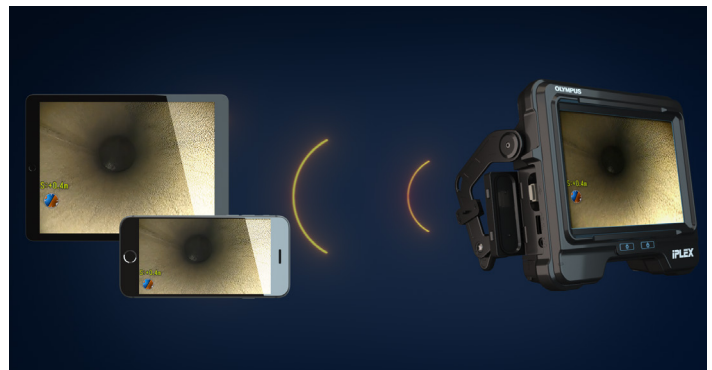

## Wireless image sharing

The USB wireless LAN adapter enables you to share live images with other colleagues\*

\*Using a recommended third-party USB wireless adapter

## Accessories



MAJ-2483  
Adjustable pole



MAJ-2486  
Push rod adapter



MAJ-2484  
Guide head



MAJ-2482  
Remote control unit



MAJ-2488  
Carrying case



NP-L7S  
Li-Ion battery

JL-2PLUS  
Battery charger



MAJ-2485  
NI-MH battery case

### Other accessories

- Optical tip adapter
- MAJ-2487 5 m relay cable
- MAJ-1935 centering device

# IPLEX™ GAir Videoscope Specifications

## Scope Unit

Model No.	IV98200GA		IV98300GA	
Insertion tube	Scope diameter	ø8.5 mm		
	Scope length	20 m (65.6 ft)	30 m (98.4 ft)	
	Exterior	High-durability tungsten braid		
	Tube flexibility	Tapered Flex insertion tube with flexibility gradually increasing toward the distal end		
Optical system	Field of view	Selectable by optical adaptor		
	Direction of view			
illumination	LED illumination			
Articulation Section	Articulation angle (all-way)	90°		
	Articulation operation	Pneumatic articulation with built-in air compressor		

## Main Unit

Model No.	IV9000GA		
Dimensions (W x H x D)	359 x 465 x 307 mm (14.1 in. x 18.3 in. x 12.1 in.) (protruding parts not included)		
Weight (main unit)	11.7 kg (25.8 lb)		
Approx. system weight (with battery and SDHC card)	When combined with IV98200GA: 15.3 kg (33.7 lb)	When combined with IV98300GA: 16.4 kg (36.2 lb)	
LCD monitor	8-inch daylight view WVGA LCD with capacity-type touch screen, 5 step adjustable LCD backlight		
Video output	Type A HDMI 1.4		
Headset (microphone in/ audio out)	ø3.5 mm mini plug CTIA		
USB connector	Type A connector, Version 2.0 standards Can be connected to a USB wireless LAN adapter (recommended) or remote control unit (optional)		
Power supply	Li-Ion battery: 16 V nominal, approx. 180-minute operating time 100 V to 240 V, 50/60 Hz (with supplied AC adaptor) External battery (with typeD Ni-MH battery x8): 9.6 V		
Recording media	Normal	SDHC (with supplied SDHC, or using the recommended Class 10 SDHC)	
	Constant Video	microSDHC (using the recommended Class 10 microSDHC)	
Image adjustment	Zoom function	Digital seamless zoom (up to 5 times)	
	Gain control	4-step adjustable gain control (Manual, Auto, WIDER1, WIDER2)	
	Dynamic noise reduction	Available	
	Sharpness control	4-step adjustable sharpness control	
	Saturation control	3-mode adjustable control of color saturation (Monotone, Natural, Vivid)	
	Title text options	30-character display	
	Display text options	30-character title display, mark, free drawing	
	Image display functions	Live image can be inverted to right and left, inverted to up and down, and rotated 180 degrees	
	Gravity indicator	Display gravity indicator according to the orientation of scope distal end	
	Insertion length indicator	Indicates insertion length according to the drum rotation. Insertion length can set to zero at any length	
	Live image orientation	Depending on the orientation of the scope tip, live image can be rotated and displayed to match the direction of gravity to the bottom of the LCD display	
Still image recording	Resolution	H640 x V480 (Pixel)	
	Recording format	Compressed JPEG format	
Video recording	Resolution	H640 x V480 (Pixel)	
	Recording format	MPEG 4 AVC/H.264 Conforms to baseline profile; Windows Media Player 12 compatible	
Wireless LAN	Directly connect to an external wireless device equipped with iOS to stream live images		
Scaler measurement	Distance between two points based on a known measurement in the same plane		

## Optical Adaptor Specifications

	AT120D/NF-IV98GA	AT120D/FF-IV98GA	AT120S/NF-IV98GA	AT120S/FF-IV98GA	AT220D-IV98GA
Optical system	Field of view	120°	120°	120°	220°
	Direction of view	Forward	Forward	Side	Side
	Depth of field*1	4 to 190 mm	25 to ∞ mm	1 to 25 mm	6 to ∞ mm
Distal end	Outer diameter*2	ø8.5 mm	ø8.5 mm	ø8.5 mm	ø8.5 mm
	Distal end*3	26.4 mm	26.4 mm	33.3 mm	33.3 mm

## Operating Environment

Operating temperature	Insertion tube	In air: -25 to 100 C° (-13 °F to 212 °F)
		In water: 10 to 30 C° (50 °F to 86 °F)
Relative humidity	Other parts	In air: -15 to 48 C° (5 °F to 118.4 °F) (with Li-Ion battery)
		In air: 0 to 40 C° (32 °F to 104 °F) (with AC power adapter)
Liquid resistance	All parts	15 to 90% (relative humidity)
Waterproofing	All parts	Operable when exposed to machine oil, light oil or 5 % saline solution
		Operable under water with viewing tip adaptor attached Up to an equivalent to 30 m (98.4 ft) in depth
	Insertion tube	Operable under water with viewing tip adaptor attached Up to an equivalent to 30 m (98.4 ft) in depth
	Other parts	Not dustproof, waterproof or dripproof

\*1. Indicates the viewing distance with optimal focus.

\*2. The adaptor can be inserted into a ø8.5 mm and ø10 mm hole when it is mounted on the scope.

\*3. Indicates the length of the rigid portion at the scope's distal end when mounted.

### • EVIDENT CORPORATION is ISO14001 certified.

For details on certification registration, visit <https://www.olympus-ims.com/en/iso>

### • EVIDENT CORPORATION is ISO9001 certified.

- This product is designed for use in industrial environments for EMC performance. Using it in a residential environment may affect other equipment.
- All company and product names are registered trademarks and/or trademarks of their respective owners.
- Images on the PC monitors are simulated.
- Specifications and appearances are subject to change without any notice or obligation on the part of the manufacturer.

[EvidentScientific.com](http://EvidentScientific.com)

**EVIDENT**

EVIDENT CORPORATION  
Shinjuku Monolith, 2-3-1 Nishi-Shinjuku, Shinjuku-ku, Tokyo 163-0910, Japan

**OLYMPUS**

N8602057-112023