

C-mount 0.35X camera adapter

U-TV0.35XC-2

This product is a camera adapter equipped with C-mount, which enables to acquire the wide field image using the digital camera, etc. The adapter ensures the transmittance covering from the visible range to the near-infrared range.

1 System diagram

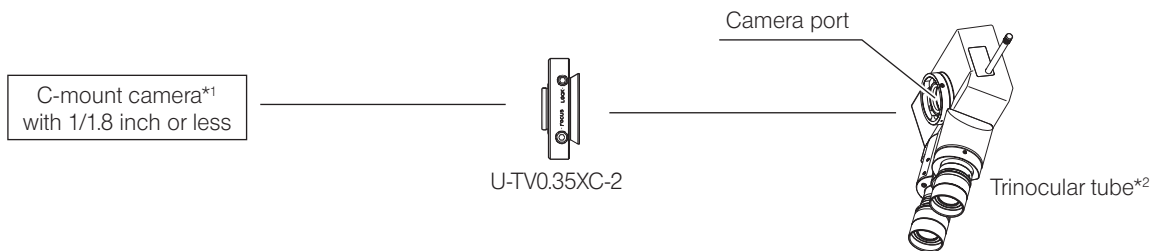

*1 Restrictions on the camera to be used

- If the external dimensions of the camera are 68 mm or more from the optical axis in the lateral direction, the camera may be interfered depending on the microscope system to be used.
- A camera cannot be used if its C-mount surface is recessed from the camera body surface.
- If using the camera with a larger image sensor than specified, the light deficiency may occur in the peripheral areas.
- Even though using the camera with a specified image sensor, the light deficiency may occur in the peripheral areas. For restrictions on your camera, contact Olympus.
- If the camera has high sensitivity or is not provided with the auto light intensity control function, the image may be over-exposed. In this case, lower the light intensity level of the microscope.

*2 This product can be mounted on the camera port of the trinocular tube (U-TR30-2, U-TR30NIR, U-SWTR-3, SZX-TR30-2, SZX2-TR30PT, etc.) or the side port of the IX3/IX2 series.

NOTE When disposing of this product, be sure to follow the regulations and rules of your local government. Contact Olympus for any questions.

2 Assembly

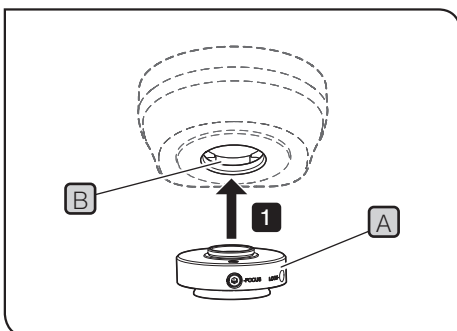

- NOTE**
- Do not touch the C-mount thread, since it is sharp.
 - Since the C-mount camera adapter is a precision instrument incorporating lens components, be careful not to drop it when attaching or detaching it. If it is dropped, damage or injury may be caused. Particularly, be careful for the broken glass.

TIP If lens components get dirty, clean them by referring to the instruction manual provided with the microscope.

1 Screw the C-mount camera adapter **A** into the C-mount thread **B** of the camera firmly.

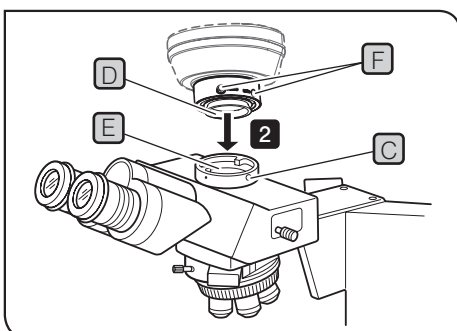

2 Loosen the clamping screw **C** of the camera port of the trinocular tube using the Allen screwdriver provided with the microscope, and then insert the mount dovetail **D** of the C-mount camera adapter into the camera port **E** of the trinocular tube.

TIP The screws (LOCK/FOCUS) **F** have to be operated while adjusting the parfocality. Attach the C-mount camera adapter in the direction so that you can operate the screws (LOCK/FOCUS) easily.

3 Tighten the clamping screw **C** firmly.



3 Operation

Adjusting the microscope

- 1 Turn ON the light source of the microscope and adjust required portions of the microscope to make it ready for observation.
- 2 Set the light path of the trinocular tube to the camera light path.

Adjusting the camera and monitor

Adjust colors, etc. according to the instruction manual of the camera and monitor in use. (The center of the field of view through the eyepieces and that of the image acquired by the camera may not coincide completely, but this is a matter of function of the image sensor adjustment mechanism of the camera, and not a malfunction.)

Adjusting the parfocality between the visually observed image and the image on monitor

By adjusting the parfocality, the image won't be defocused when the observation light path of the microscope is changed.

Before adjusting the parfocality, adjust the diopter of the microscope in advance. For procedures to adjust the diopter, refer to the instruction manual for the microscope in use.

Use the Allen screwdriver provided with the microscope for adjusting the parfocality.

- 1 Change the objective of the microscope to the high magnification objective, look into the eyepieces and bring the specimen into focus.
- 2 Change the objective to the low magnification objective and check that the image is in focus by looking through eyepieces. Then, change to the camera light path and observe the image on monitor.
- 3 Loosen the clamping screw (LOCK) **A** of the C mount camera adapter using the Allen screwdriver.
- 4 While observing the image on monitor, adjust its focus by rotating the parfocality adjustment screw (FOCUS) **B** slowly using the Allen screwdriver.
- 5 When it is in focus, tighten the clamping screw (LOCK) **A** using the Allen screwdriver.

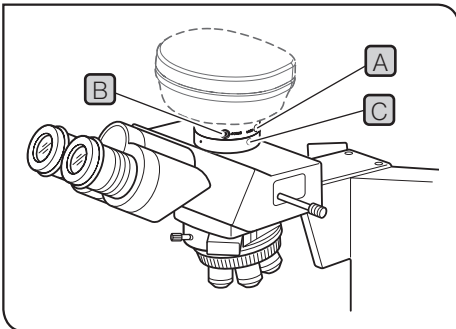

Adjusting the direction between the visually observed image and the image on monitor.

- 1 Loosen the clamping screw **C** of the camera port of the trinocular tube.
- 2 Rotate the C-mount camera adapter so that the direction of the visually observed image coincides with that of the image on monitor, and tighten the clamping screw **C** firmly.

4 Imaging field area

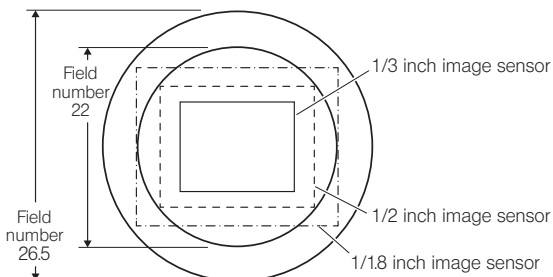

TIP

For your reference, the following diagram shows the areas of imaging field determined by the field of view when eyepieces with a field number of 22 or 26.5 are used and the size of the image sensor through the C-mount camera adapter.

$$\text{Magnification on monitor} = \text{Objective magnification} \times \text{C mount camera adapter magnification (0.35X)} \times \frac{\text{Monitor diagonal length}^*}{\text{Image sensor diagonal length}^*}$$

* The diagonal length of the monitor and that of the image sensor differ depending on manufacturers.

(Image sensor Reference data) 1 inch : 16.16mm, 2/3 inch : 11mm, 1/1.8 inch : 8.8mm, 1/2 inch : 8.08mm, 1/3 inch : 6mm, 1/4 inch : 4mm