

INSTRUCTIONS

SZX2-ILLC16/ILLC10

SZX2 Coaxial vertical illuminators

This instruction manual is for the Olympus SZX2 coaxial vertical illuminator. To ensure the safety, obtain optimum performance and familiarize yourself fully with the use of this equipment, we recommend that you study this manual thoroughly before operating the equipment.

Retain this instruction manual in an easily accessible place near the work desk for future reference.

For details of products other than SZX2-ILLC16/ILLC10, see “2 Nomenclature” (P.4) and “3 Assembly” (P.5).

Optical Microscope Accessory

Contents

Important.....	1
1 Usable observation magnifications.....	3
2 Nomenclature	4
3 Assembly.....	5
4 Summary of operation procedure.....	8
5 Operation	9
6 Troubleshooting guide.....	11





Important

1 Getting ready

1. This manual pertains only to the operating procedure of the coaxial vertical illuminators. Make sure that you also read the instruction manuals for the SZX16/SZX10/SZX7 microscope and light source so that you understand the overall operating instructions of the entire microscope system.
2. The coaxial vertical illuminator is a precision instrument. Handle it with care and avoid subjecting it to sudden or severe impact.
3. To avoid breaking the light guide fiber (for this reduces the amount of light available), use the light guide with bending radius of 60 mm or more.
4. Do not use the coaxial vertical illuminator where it may be subjected to direct sunlight, high temperatures and humidity, dust or vibrations.

2 Maintenance and storage

1. To clean the lenses and other glass components, simply blow dirty away using a commercially available blower and wipe gently using a piece of cleaning paper (or clean gauze).
If a lens is stained with fingerprints or oil smudges, wipe it gauze slightly moistened with commercially available absolute alcohol.

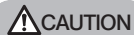

CAUTION Since the absolute alcohol is highly flammable, it must be handled carefully.

Be sure to keep it away from open flames or potential sources of electrical sparks – for example, electrical equipment that is being switched on or off.

Also remember to always use it only in a well-ventilated room.

2. Do not use organic solvents to clean non-optical components. If smudges are difficult to clean, wipe them with a soft cloth slightly moistened with a diluted neutral detergent.
3. Never disassemble any part of the unit as this could cause malfunctions or reduced performance.

3 Caution

If the coaxial illuminator is used in a manner not specified by this manual, the safety of the user may be imperiled. In addition, the equipment may also be damaged. Always use the equipment as outlined in this instruction manual.

The following symbols are used to set off text in this instruction manual.

 **CAUTION** : Indicates that failure to follow the instructions in the warning could result in bodily harm to the user and/or damage to equipment (including objects in the vicinity of the equipment).

 **NOTE** : Indicates that failure to follow the instructions could result in damage to equipment.

 **TIP** : Indicates commentary (for ease of operation and maintenance).

1

Usable observation magnifications

The following table lists usable objectives and observation ranges (when 10X eyepieces are used).

- Total magnification when the coaxial vertical illuminator is used:

Total magnification (A) = Objective magnification x Zoom magnification (B) x Eyepiece magnification (10X) x 1.5

Coaxial vertical illuminator SZX2-ILLC16			Coaxial vertical illuminator ILLC10				
Objective	zoom microscope body SZX2-ZB16		Objective	zoom microscope body SZX2-ZB19		zoom microscope body SZX-ZB7	
	Total mag. (A)	Zoom mag. (B)		Total mag. (A)	Zoom mag. (B)	Total mag. (A)	Zoom mag. (B)
SDFPLFL 0.3X	18X	4X	DFPL 0.5X-4	15X	2X	19X	2.5X
SDFPLAPO 0.5XPF	19X	2.5X	DFPL 0.75X-4	14X	1.25X	18X	1.6X
SDFPLAPO 0.8X	12X	1X	DFPLAPO 1X-4	12X	0.8X	15X	1X
SDFPLAPO 1XPF	37.5X	2.5X	SZX-ACH 1X	15X	1X	19X	1.25X
SDFPLAPO 1.6XPF	-	-	DFPLAPO 1.25X	12X	0.63X	15X	0.8X
SDFPLAPO 2XPF	-	-	SZX-ACH 1.25X	12X	0.63X	15X	0.8X
			DFPL 1.5X-4	56X	2.5X	18X	0.8X
			DFPL 2X-4	96X	3.2X	60X	2X

TIP

The above data is applicable to specimens with mirror-type surfaces. Specimens with scattering type surfaces can be observed at magnifications lower than those listed above.

2 Nomenclature

Coaxial vertical illuminator
SZX2-ILLC16
SZX2-ILLC10

TIP

This illustration uses the SZX2-ILLC16. The light guide mount of the SZX2-ILLC10 is slightly narrower than that shown here.

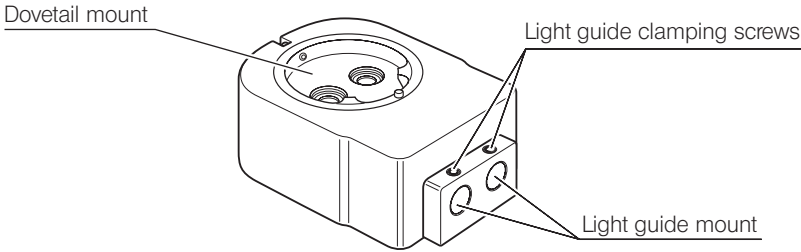

Quarter-wave plate
SZX2-ILLC 1/4

Clamping knob

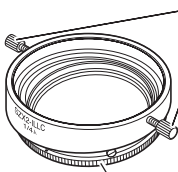

Branched flexible light guide
LG-DF

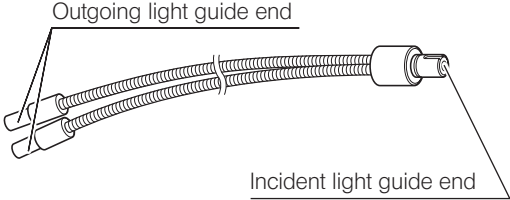

3 Assembly

The diagram below shows how to assemble the various modules of this equipment. The numbers in the diagram indicate the order of assembly.

NOTE

Before assembling, make sure that all parts are free of dust and dirt, and avoid scratching any parts or touching the glass surfaces.

TIP

Only a limited number of intermediate attachments can be mounted. However, the coaxial vertical illuminator (SZX2-ILLC16/ILLC10) is not considered to be an intermediate attachment so it is always possible to mount an intermediate attachment above the SZX2-ILLC16/ILLC10. Be sure to mount the SZX2-ILLC16/ILLC10 directly above the zoom microscope body.

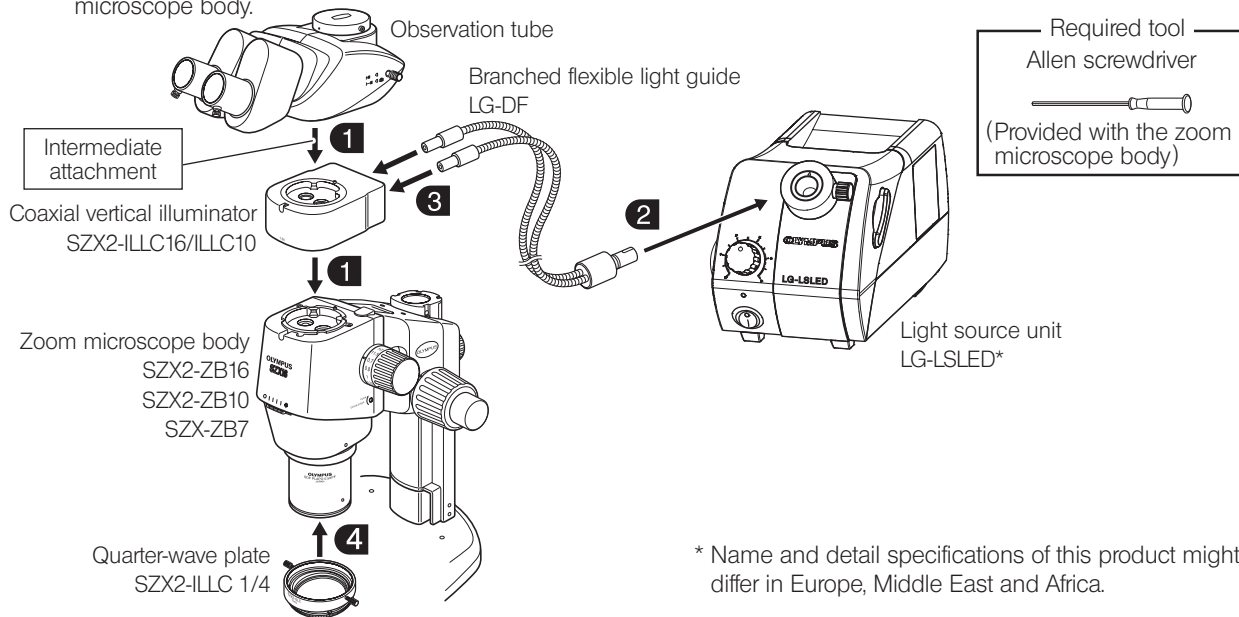

* Name and detail specifications of this product might differ in Europe, Middle East and Africa.

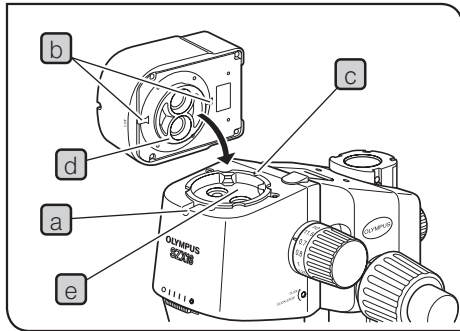

1 Mounting the coaxial vertical illuminator

- 1 Loosen the observation tube clamping screw **a** with the provided Allen screwdriver and remove the observation tube.
- 2 Align the positioning groove **b** on the coaxial vertical illuminator with the positioning pin **c** on the microscope body. Then insert the dovetail **d** at the bottom of the coaxial vertical illuminator into the dovetail mount **e** on the microscope body.

NOTE

The coaxial vertical illuminator can also be mounted in the opposite orientation to that shown in figure. However this orientation is not recommended because it makes observation difficult.

- 3 Tighten the observation tube clamping screw **a** on the microscope body with the Allen screwdriver.
- 4 Mount the observation tube on the coaxial vertical illuminator.

2 Mounting the branched flexible light guide (light-incident side)

For details, see the instruction manual of the LG-LSLED (LED light source for light guide).

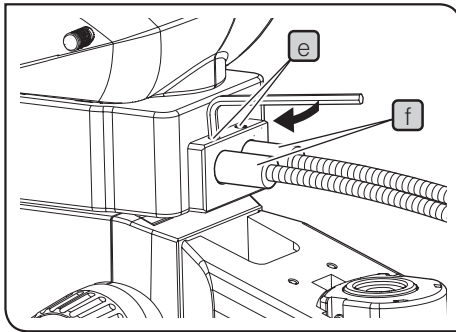

3

Mounting the branched flexible light guide (light-emitting side)

- 1 Loosen the light guide clamping screws **e** on the coaxial vertical illuminator with the Allen screwdriver. Insert the outgoing light guide end **f** until it stops (the force required for insertion will increase in the middle due to a spring). Tighten the clamping screws **e**.

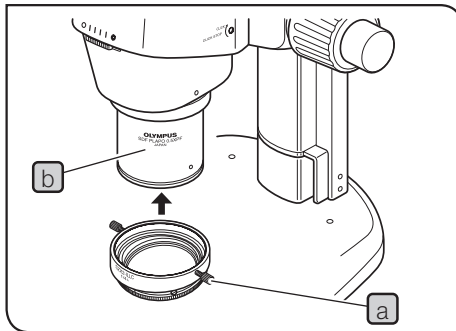

4

Mounting the quarter-wave plate

- 1 Loosen the two quarter-wave plate clamping knobs **a**.
- 2 Fit the quarter-wave plate onto the tip of the objective **b** and secure the clamping knobs.

NOTE

The quarter-wave plate should be mounted so that the clamping knobs are on the side when seen from the front of the microscope (i.e., so that the module indication faces the front).

4 Summary of operation procedure

Ref. Page

Preparation

- 1 Check that the required modules are mounted.....(P. 6, 7)
- 2 Adjust the orientation of the microscope body and the rotation tension of the coarse focus adjustment knob.*
- 3 Turn on the main switch of the light source unit and adjust the brightness.*
- 4 Adjust the orientation of the quarter-wave plate.(P. 9)

Observation procedure

- 1 Place a specimen on the stage.
- 2 Adjust the brightness to an easy-to-observe level.*
- 3 Turn the quarter-wave plate rotation annulus to select an optimum rotation position.....(P. 10)
- 4 Observe the specimen with the standard observation procedure.*

* Refer to the instruction manuals of the SZX16/SZX10/SZX7 microscope and the LG-LSLED light source unit.

5 Operation

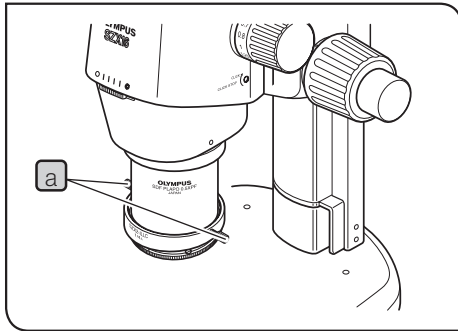

1 Adjusting the quarter-wave plate orientation

NOTE If the quarter-wave plate is not positioned properly, flare may be produced even inside the usable observation area

- 1 Slightly loosen the two quarter-wave plate clamping knobs **a**.
- 2 Adjust the quarter-wave plate orientation so that the clamping knobs are exactly to the side of the microscope when seen from the front (i.e., so that the module indication faces the front).

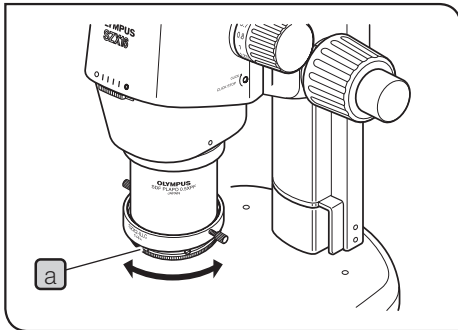

2 Adjusting the brightness

Adjustment according to light source unit	Adjust the brightness by turning the light intensity adjustment knob on the light source unit.
Adjustment according to quarter-wave plate rotation annulus	Adjust brightness by turning the quarter-wave plate rotation annulus a on the quarter-wave plate.

3 Observing the specimen

- A. Observing an IC chip, wafer, etc.
 - 1. Brighten the field of view by turning the quarter-wave plate rotation annulus.
 - 2. If the field of view is too bright and glaring, adjust the brightness as described in **2** above.

- B. Reflected light polarized observation of liquid crystal, etc.
 - 1. Perform Cross-Nicol observation (with the darkest field of view).
 - 2. For accurate Cross-Nicol adjustment, place a flat, mirror-surfaced specimen on the specimen and make the field of view as dark as possible by turning the quarter-wave plate rotation annulus.
 - 3. Observe the specimen by rotating it on a horizontal plane.

6 Troubleshooting guide

Under certain conditions, performance of this equipment may be adversely affected by factors other than defects. If a problem occurs, please review the following list and take remedial action as needed.

If you cannot solve the problem after checking the entire list, please contact your local Olympus representative for assistance.

Problem	Cause	Remedy
Field of view is not evenly illuminated.	The light guide is not mounted properly.	Mount the light guide properly.
Contrast is poor.	The quarter-wave plate is not adjusted.	Adjust the plate. (P. 9)
The view is noticeably different between the left and right fields of view.	The quarter-wave plate clamping position is not adjusted properly.	Adjust the clamping position correctly. (P. 9)

Repair request

If you cannot solve the problems even though taking actions described in Troubleshooting, please contact Olympus for assistance. At that time, please tell them the following information as well.

- Product name and abbreviation (Example: Coaxial vertical illuminator SZX2-ILLC16)
- Product number
- Problem

This product is manufactured by **EVIDENT CORPORATION** effective as of Apr. 1, 2022.
Please contact our "Service Center" through the following website for any inquiries or issues related to this product.

EVIDENT CORPORATION

6666 Inatomi, Tatsuno-machi, Kamiina-gun, Nagano 399-0495, Japan

(Life science solutions)

Service Center

<https://www.olympus-lifescience.com/support/service/>



(Life science solutions)

Our Website

<https://www.olympus-lifescience.com>



(Industrial solutions)

Service Center

<https://www.olympus-ims.com/service-and-support/service-centers/>



(Industrial solutions)

Our Website

<https://www.olympus-ims.com>



AX7507 07

Issued in March, 2022