



# AxSEAM

## Longitudinal Weld Scanner

### User's Manual

10-013816-01EN — Rev. 5  
September 2022

This instruction manual contains essential information on how to use this Evident product safely and effectively. Before using this product, thoroughly review this instruction manual. Use the product as instructed. Keep this instruction manual in a safe, accessible location.

EVIDENT CANADA, 3415, Rue Pierre-Ardouin, Québec (QC) G1P 0B3 Canada

Copyright © 2022 by Evident. All rights reserved. No part of this publication may be reproduced, translated, or distributed without the express written permission of Evident.

This document was prepared with particular attention to usage to ensure the accuracy of the information contained therein, and corresponds to the version of the product manufactured prior to the date appearing on the title page. There could, however, be some differences between the manual and the product if the product was modified thereafter.

The information contained in this document is subject to change without notice.

Part number: 10-013816-01EN

Rev. 5

September 2022

Printed in Canada

All brands are trademarks or registered trademarks of their respective owners and third party entities.

---

---

# Table of Contents

---

<b>List of Abbreviations .....</b>	<b>7</b>
<b>Important Information – Please Read Before Use .....</b>	<b>9</b>
Intended Use .....	9
Instruction Manual .....	9
Device Compatibility .....	10
Repair and Modification .....	10
Safety Symbols .....	10
Safety Signal Words .....	11
Note Signal Words .....	12
Safety .....	12
Warnings .....	12
Battery Precautions .....	13
Regulations for Shipping Products with Lithium-Ion Batteries .....	15
Equipment Disposal .....	15
BC (Battery Charger - California, USA Community) .....	15
CE (European Community) .....	16
UKCA (United Kingdom) .....	16
RCM (Australia) .....	16
WEEE Directive .....	16
China RoHS .....	17
Korea Communications Commission (KCC) .....	18
EMC Directive Compliance .....	18
FCC (USA) Compliance .....	19
ICES-001 (Canada) Compliance .....	20
Warranty Information .....	20
Technical Support .....	21

<b>Introduction .....</b>	<b>23</b>
<b>1. Overview .....</b>	<b>25</b>
1.1 AxSEAM Case Contents .....	25
1.2 Scanner Key Components .....	26
1.2.1 Frame .....	27
1.2.2 Longitudinal Inspection Scanning Pivot System .....	27
1.2.3 Circumferential Inspection Scanning Pivot System .....	28
1.2.4 Wheels .....	28
1.2.5 Brake System .....	29
1.2.6 Encoder .....	29
1.2.7 Umbilical Attachment .....	30
1.2.8 Quick-Reference Probe Holder Position Rulers .....	30
1.3 ScanDeck™ module .....	31
1.4 Probe Holder .....	33
<b>2. Scanner Assembly and Setup .....</b>	<b>39</b>
2.1 Changing the Probe Holder Mounting Rail Angle for Longitudinal Scanning .....	39
2.2 Changing the Frame Angle for Circumferential Scanning .....	41
2.3 Installing a Probe Holder on the Scanner .....	43
2.4 Sliding the Probe Holder .....	45
2.5 Operating the Probe Holders .....	47
2.6 Using Shims with 40 mm Wide Wedges .....	50
2.7 Basic Operations on Probes and Wedges .....	52
2.7.1 Adjusting the Carbide Wear Pins on Wedges .....	52
2.7.2 Replacing a Phased Array Probe or a Wedge .....	53
2.8 Flipping a Probe Holder .....	54
2.9 Connecting Cables and Tubes .....	58
2.10 Connecting the Scanner .....	61
2.11 Choosing and Changing the Probe Holder Spring Tension .....	62
<b>3. Preparing the Scanner for an Inspection .....</b>	<b>65</b>
3.1 Attaching the Lanyard .....	65
3.2 Connecting to the Water Pump .....	66
3.3 Installing the Scanner on the Pipe .....	66
3.4 Adjusting the Probe Separation Distance .....	68
<b>4. Operating the AxSEAM Scanner .....</b>	<b>69</b>
4.1 Using the Brake System .....	69
4.2 Working with the ScanDeck™ module's Feedback .....	71

---

4.2.1	Coupling Check .....	71
4.2.2	Speed Check .....	71
4.2.3	Laser Button .....	71
4.2.4	Start Acquisition Button .....	72
4.3	Operating the Scanner .....	72
<b>5.</b>	<b>Maintenance .....</b>	<b>75</b>
5.1	Cleaning the Scanner .....	75
5.2	Replacing Wheels .....	76
5.3	Removing the Yoke Pivoting Beam .....	79
<b>6.</b>	<b>Spare Parts .....</b>	<b>83</b>
6.1	Top Assembly .....	84
6.2	Magnetic Wheel .....	86
6.3	Encoder .....	87
6.4	Probe Holder .....	88
6.5	TOFD Yoke Arm .....	90
6.6	Phased Array Yoke Arm .....	91
6.7	Cable Management .....	92
6.8	Rear Assembly Part 1 .....	94
6.9	Rear Assembly Part 2 .....	95
6.10	Front Assembly Part 1 .....	96
6.11	Front Assembly Part 2 .....	98
<b>7.</b>	<b>Specifications .....</b>	<b>99</b>
7.1	General Specifications .....	99
7.2	Connectors .....	104
	<b>List of Figures .....</b>	<b>107</b>
	<b>List of Tables .....</b>	<b>109</b>

---



---

## List of Abbreviations

---

DLA	Dual Linear Array
EFUP	environment-friendly use period
LED	light-emitting diode
SLA	spring-loaded arms
UT	ultrasonic testing





---

## Important Information — Please Read Before Use

---

### Intended Use

The AxSEAM is designed to perform nondestructive inspections on industrial and commercial materials.



#### **WARNING**

Do not use the AxSEAM for any purpose other than its intended use. It must never be used to inspect or examine human or animal body parts.

---

### Instruction Manual

This instruction manual contains essential information on how to use this product safely and effectively. Before using this product, thoroughly review this instruction manual. Use the product as instructed. Keep this instruction manual in a safe, accessible location.

---

#### **IMPORTANT**

Some of the details of components illustrated in this manual may differ from the components installed on your device. However, the operating principles remain the same.

---

## Device Compatibility

Only use this device with the approved ancillary equipment provided by Evident. Equipment provided by Evident and approved for use with this device is described later in this manual.

---



### CAUTION

Always use equipment and accessories that meet Evident specifications. Using incompatible equipment could cause equipment malfunction and/or damage, or human injury.

---

## Repair and Modification

This device does not contain any user-serviceable parts. Opening the device might void the warranty.

---



### CAUTION

In order to prevent human injury and/or equipment damage, do not disassemble, modify, or attempt to repair the device.

---

## Safety Symbols

The following safety symbols might appear on the device and in the instruction manual:



General warning symbol

This symbol is used to alert the user to potential hazards. All safety messages that follow this symbol shall be obeyed to avoid possible harm or material damage.

---



High voltage warning symbol

This symbol is used to alert the user to potential electric shock hazards greater than 1000 volts. All safety messages that follow this symbol shall be obeyed to avoid possible harm.

## Safety Signal Words

The following safety symbols might appear in the documentation of the device:



**DANGER**

The DANGER signal word indicates an imminently hazardous situation. It calls attention to a procedure, practice, or the like, which, if not correctly performed or adhered to, will result in death or serious personal injury. Do not proceed beyond a DANGER signal word until the indicated conditions are fully understood and met.



**WARNING**

The WARNING signal word indicates a potentially hazardous situation. It calls attention to a procedure, practice, or the like, which, if not correctly performed or adhered to, could result in death or serious personal injury. Do not proceed beyond a WARNING signal word until the indicated conditions are fully understood and met.



**CAUTION**

The CAUTION signal word indicates a potentially hazardous situation. It calls attention to an operating procedure, practice, or the like, which, if not correctly performed or adhered to, may result in minor or moderate personal injury, material damage, particularly to the product, destruction of part or all of the product, or loss of data. Do not proceed beyond a CAUTION signal word until the indicated conditions are fully understood and met.

## Note Signal Words

The following note signal words could appear in the documentation of the device:

**IMPORTANT**

The IMPORTANT signal word calls attention to a note that provides important information, or information essential to the completion of a task.

**NOTE**

The NOTE signal word calls attention to an operating procedure, practice, or the like, which requires special attention. A note also denotes related parenthetical information that is useful, but not imperative.

**TIP**

The TIP signal word calls attention to a type of note that helps you apply the techniques and procedures described in the manual to your specific needs, or provides hints on how to effectively use the capabilities of the product.

## Safety

Before turning on the device, verify that the correct safety precautions have been taken (see the following warnings). In addition, note the external markings on the device, which are described under “Safety Symbols.”

## Warnings



**WARNING**

### General Warnings

- Carefully read the instructions contained in this instruction manual prior to turning on the device.
- Keep this instruction manual in a safe place for further reference.

- Follow the installation and operation procedures.
- It is imperative to respect the safety warnings on the device and in this instruction manual.
- If the equipment is used in a manner not specified by the manufacturer, the protection provided by the equipment could be impaired.
- Do not install substitute parts or perform any unauthorized modification to the device.
- Service instructions, when applicable, are for trained service personnel. To avoid the risk of electric shock, do not perform any work on the device unless qualified to do so. For any problem or question regarding this device, contact Evident or an authorized Evident representative.
- Do not touch the connectors directly by hand. Otherwise, a malfunction or electric shock may result.
- Do not allow metallic or foreign objects to enter the device through connectors or any other openings. Otherwise, a malfunction or electric shock may result.

**WARNING****Electrical Warning**

The device must only be connected to a power source corresponding to the type indicated on the rating label.

**CAUTION**

If a non-approved power supply cord not dedicated to Evident products is used, Evident will not be able to ensure the electrical safety of the equipment.

**Battery Precautions****CAUTION**

- Before disposing of a battery, check your local laws, rules, and regulations, and follow them accordingly.

- Transportation of lithium-ion batteries is regulated by the United Nations under the United Nations Recommendations on the Transport of Dangerous Goods. It is expected that governments, intergovernmental organizations, and other international organizations shall conform to the principles laid down in these regulations, thus contributing to worldwide harmonization in this field. These international organizations include the International Civil Aviation organization (ICAO), the International Air Transport Association (IATA), the International Maritime Organization (IMO), the US Department of Transportation (USDOT), Transport Canada (TC), and others. Please contact the transporter and confirm current regulations before transportation of lithium-ion batteries.
- For California (USA) only:  
The device may contain a CR battery. The CR battery contains perchlorate material, and special handling may be required. Refer to <http://www.dtsc.ca.gov/hazardouswaste/perchlorate>.
- Do not open, crush, or perforate batteries; doing so could cause injury.
- Do not incinerate batteries. Keep batteries away from fire and other sources of extreme heat. Exposing batteries to extreme heat (over 80 °C) could result in an explosion or personal injury.
- Do not drop, hit, or otherwise abuse a battery, as doing so could expose the cell contents, which are corrosive and explosive.
- Do not short-circuit the battery terminals. A short circuit could cause injury and severe damage to a battery making it unusable.
- Do not expose a battery to moisture or rain; doing so could cause an electric shock.
- Only use an external charger approved by Evident to charge the batteries.
- Only use batteries supplied by Evident.
- Do not store batteries that have less than 40 % remaining charge. Recharge batteries to between 40 % and 80 % capacity before storing them.
- During storage, keep the battery charge between 40 % and 80 %.
- Do not leave batteries in the AxSEAM unit during device storage.

---

## Regulations for Shipping Products with Lithium-Ion Batteries

---

### IMPORTANT

When shipping a Li-ion battery or batteries, be sure to follow all local transportation regulations.

---



### WARNING

Damaged batteries cannot be shipped through normal routes — DO NOT ship damaged batteries to Evident. Contact your local Evident representative or material disposal professionals.

---

## Equipment Disposal

Before disposing of the AxSEAM, check your local laws, rules, and regulations, and follow them accordingly.

## BC (Battery Charger - California, USA Community)



The BC marking indicates that this product has been tested and complies with the Appliance Efficiency Regulations as stated in the California Code of Regulations Title 20, Sections 1601 through 1608 for Battery Charger Systems. The internal battery charger within this device has been tested and certified pursuant to the California Energy Commission's (CEC) requirements; this device is listed on the online CEC's (T20) database.

## CE (European Community)



This device complies with the requirements of directive 2014/30/EU concerning electromagnetic compatibility, directive 2014/35/EU concerning low voltage, and directive 2015/863 which amends 2011/65/EU concerning restriction of hazardous substances (RoHS). The CE marking is a declaration that this product conforms to all the applicable directives of the European Community.

## UKCA (United Kingdom)



This device complies with the requirements of the Electromagnetic Compatibility Regulations 2016, the Electrical Equipment (Safety) Regulations 2016, and the Restriction of the Use of Certain Hazardous Substances in Electrical and Electronic Equipment Regulations 2012. The UKCA marking indicates compliance with the above regulations.

## RCM (Australia)



The regulatory compliance mark (RCM) label indicates that the product complies with all applicable standards, and has been registered with the Australian Communications and Media Authority (ACMA) for placement on the Australian market.

## WEEE Directive



In accordance with European Directive 2012/19/EU on Waste Electrical and Electronic Equipment (WEEE), this symbol indicates that the product must not be disposed of as unsorted municipal waste, but should be collected separately. Refer to your local Evident distributor for return and/or collection systems available in your country.





## China RoHS

*China RoHS* is the term used by industry generally to describe legislation implemented by the Ministry of Information Industry (MII) in the People's Republic of China for the control of pollution by electronic information products (EIP).



The China RoHS mark indicates the product's Environment-Friendly Use Period (EFUP). The EFUP is defined as the number of years for which listed controlled substances will not leak or chemically deteriorate while in the product. The EFUP for the AxSEAM has been determined to be 15 years.

**Note:** The Environment-Friendly Use Period (EFUP) is not meant to be interpreted as the period assuring functionality and product performance.



电器电子产品有害  
物质限制使用  
标志

本标志是根据“电器电子产品有害物质限制使用管理办法”以及“电子电气产品有害物质限制使用标识要求”的规定，适用于在中国销售的电器电子产品上的电器电子产品有害物质使用限制标志。

（注意）电器电子产品有害物质限制使用标志内的数字为在正常的使用条件下有害物质等不泄漏的期限，不是保证产品功能性能的期间。

产品中有害物质的名称及含量

部件名称		有害物质					
		铅及其化合物 (Pb)	汞及其化合物 (Hg)	镉及其化合物 (Cd)	六价铬及其化合物 (Cr( VI ))	多溴联苯 (PBB)	多溴二苯醚 (PBDE)
主体	机构部件	×	○	○	○	○	○
	光学部件	×	○	○	○	○	○
	电气部件	×	○	○	○	○	○

产品中有害物质的名称及含量

部件名称	有害物质					
	铅及其化合物 (Pb)	汞及其化合物 (Hg)	镉及其化合物 (Cd)	六价铬及其化合物 (Cr( VI ))	多溴联苯 (PBB)	多溴二苯醚 (PBDE)
附件	×	○	○	○	○	○

本表格依据 SJ/T 11364 的规定编制。

○：表示该有害物质在该部件所有均质材料中的含量均在 GB/T26572 规定的限量要求以下。

×：表示该有害物质至少在该部件的某一均质材料中的含量超出 GB/T26572 规定的限量要求。

## Korea Communications Commission (KCC)



Seller and user shall be noticed that this equipment is suitable for electromagnetic equipment for office work (class A) and it can be used outside the home. This device complies with the EMC requirements of Korea.

The MSIP code for the device is the following:  
MSIP-R-R-OYN-AXSEAM.

이 기기는 업무용 환경에서 사용할 목적으로 적합성평가를 받은 기기로서 가정용 환경에서 사용하는 경우 전파간섭의 우려가 있습니다.

## EMC Directive Compliance

This equipment generates and uses radio-frequency energy and, if not installed and used properly (that is, in strict accordance with the manufacturer's instructions), may cause interference. The AxSEAM has been tested and found to comply with the limits for an industrial device in accordance with the specifications of the EMC directive.

---

## FCC (USA) Compliance

---

<b>NOTE</b>
-------------

This product has been tested and found to comply with the limits for a Class A digital device, pursuant to Part 15 of the FCC Rules. These limits are designed to provide reasonable protection against harmful interference when the product is operated in a commercial environment. This product generates, uses, and can radiate radio frequency energy, and if not installed and used in accordance with the instruction manual, might cause harmful interference to radio communications. Operation of this product in a residential area is likely to cause harmful interference, in which case you will be required to correct the interference at your own expense.

---

---

<b>IMPORTANT</b>
------------------

Changes or modifications not expressly approved by the party responsible for compliance could void the user's authority to operate the product.

---

### FCC Supplier's Declaration of Conformity

Hereby declares that the product,

Product name: AxSEAM

Model: AxSEAM-MR/AxSEAM-CW

Conforms to the following specifications:

FCC Part 15, Subpart B, Section 15.107 and Section 15.109.

Supplementary information:

This device complies with Part 15 of the FCC Rules. Operation is subject to the following two conditions:

- (1) This device may not cause harmful interference.
- (2) This device must accept any interference received, including interference that may cause undesired operation.

Responsible party name:

EVIDENT CANADA

Address:

3415, Rue Pierre-Ardouin Québec (QC) G1P 0B3 Canada

Phone number:

+1 781-419-3900

## **ICES-001 (Canada) Compliance**

This Class A digital apparatus complies with Canadian ICES-001.

Cet appareil numérique de la classe A est conforme à la norme NMB-001 du Canada.

## **Warranty Information**

Evident guarantees your Evident product to be free from defects in materials and workmanship for a specific period, and in accordance with conditions specified in the Terms and Conditions available at <https://www.olympus-ims.com/en/terms/>.

The Evident warranty only covers equipment that has been used in a proper manner, as described in this instruction manual, and that has not been subjected to excessive abuse, attempted unauthorized repair, or modification.

Inspect materials thoroughly on receipt for evidence of external or internal damage that might have occurred during shipment. Immediately notify the carrier making the delivery of any damage, because the carrier is normally liable for damage during shipment. Retain packing materials, waybills, and other shipping documentation needed in order to file a damage claim. After notifying the carrier, contact Evident for assistance with the damage claim and equipment replacement, if necessary.

This instruction manual explains the proper operation of your Evident product. The information contained herein is intended solely as a teaching aid, and shall not be used in any particular application without independent testing and/or verification by the operator or the supervisor. Such independent verification of procedures becomes increasingly important as the criticality of the application increases. For this reason, Evident makes no warranty, expressed or implied, that the techniques, examples, or procedures described herein are consistent with industry standards, nor that they meet the requirements of any particular application.

Evident reserves the right to modify any product without incurring the responsibility for modifying previously manufactured products.

## **Technical Support**

Evident is firmly committed to providing the highest level of customer service and product support. If you experience any difficulties when using our product, or if it fails to operate as described in the documentation, first consult the user's manual, and then, if you are still in need of assistance, contact our After-Sales Service. To locate the nearest service center, visit the Service Centers page on the Evident Scientific Web site.



---

# Introduction

---

This manual provides instructions for assembling, installing, and operating the AxSEAM scanner. The AxSEAM scanner is a versatile pipe and tube semi-automatic scanner that can be used to inspect longitudinal welds on pipes of 152.4 mm (6 in.) outside diameter (OD) and greater as well as circumferential welds on pipes of 254 mm (10 in.) OD and greater.

The AxSEAM was designed to be easy to set up. Only a few operations are required to adapt to a new diameter or configuration. No tools is necessary to operate the AxSEAM.

This manual is organized to allow a progressive understanding of the scanner's different functions. Each section, however, is complete in itself. This manual is therefore a useful reference.

---

<b>NOTE</b>
-------------

The AxSEAM scanner is designed to be used with an OmniScan series instrument. For details on instrument and software operation, refer to the *OmniScan MX, MX2, and X3 User's Manual* or *OmniScan SX User's Manual*, as well as the *OmniScan MXU Software User's Manual*.

---





---

# 1. Overview

---

This chapter provides an overview of the AxSEAM scanner components. The scanner is shown in Figure 1-2 on page 27. A description of the components follows.

## 1.1 AxSEAM Case Contents

The AxSEAM scanner case contents are shown in Figure 1-1 on page 25.

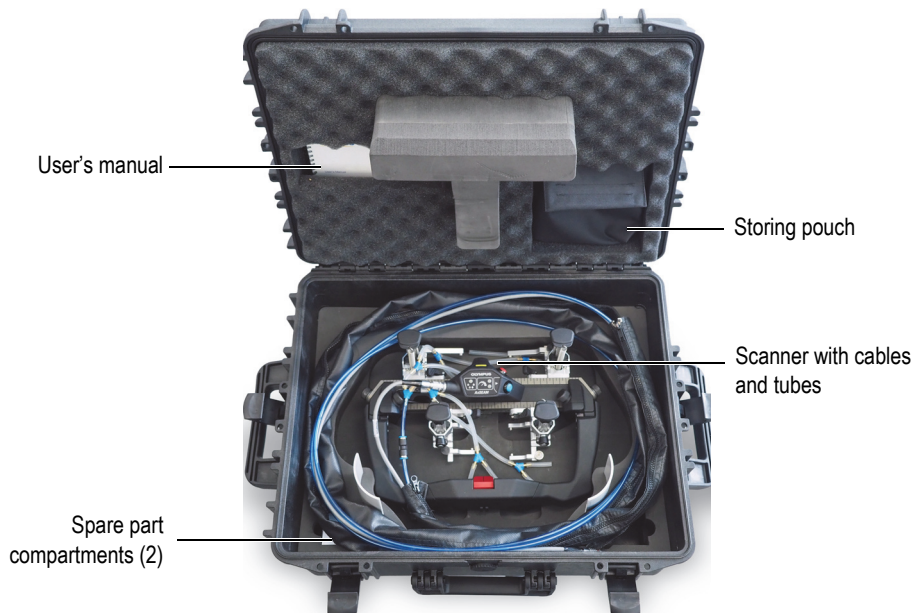

**Figure 1-1 Case contents**



**WARNING**



The AxSEAM scanner has magnetic wheels that must be carefully handled to prevent the risk of injury and equipment damage from magnetic fields and inadvertent attractive forces. Before unpacking and handling, observe the magnetic wheel safety precautions, as outlined in the warning note on page 28.

---

The case is configured to hold the following parts (for details, see “Spare Parts” on page 83):

- AxSEAM scanner unit with cable assembly and probe holders
- Flexible magnetic straightedge
- Spare parts kit including screws and basic hardware parts
- Printed copy of *AxSEAM Scanner User's Manual*

## 1.2 Scanner Key Components

Main components are detailed in Figure 1-2 on page 27.

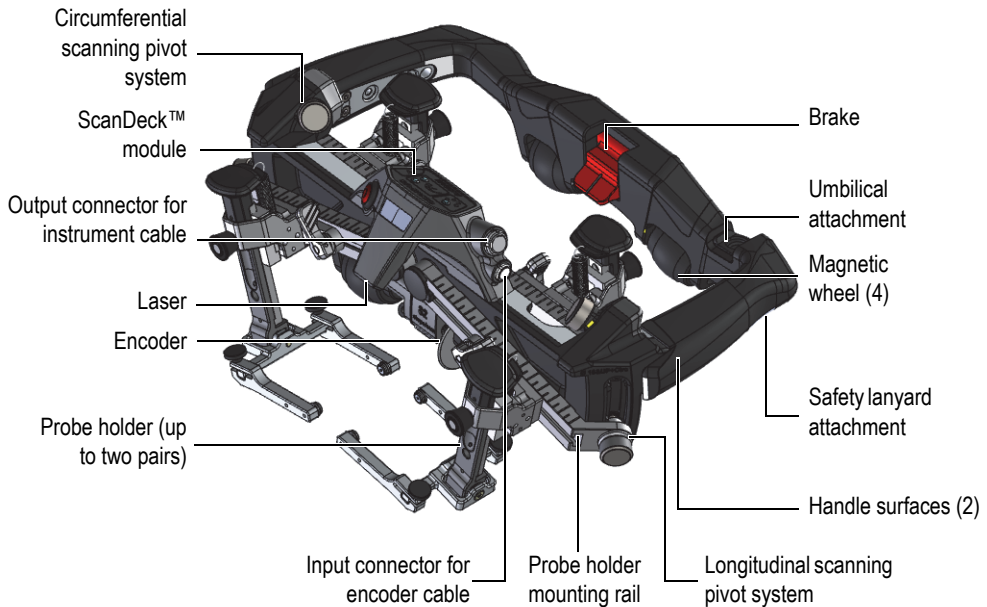

**Figure 1-2 The AxSEAM scanner**

### 1.2.1 Frame

The scanner frame is manually moved across an inspection surface by an operator. Two handle surfaces are provided on the frame to control the scanner.

### 1.2.2 Longitudinal Inspection Scanning Pivot System

This system is used to adapt to different pipe diameters when scanning in the longitudinal direction. For the pipe diameters of 406.4 mm (16 in.) and smaller, put the system at the lowest position. For the pipe diameters greater than 406.4 mm (16 in.), put the system at the higher position. Depending on the probe model and separation distance, some configurations may require to have the system set at the higher position on pipes that are between 406.4 mm (16 in.) OD and 660.4 mm (26 in) OD.

### 1.2.3 Circumferential Inspection Scanning Pivot System

This system is used to adapt to different pipe diameters when scanning in the circumferential direction. For the pipe diameters of 406.4 mm (16 in.) and smaller, put the system in its pivoted position. For the pipe diameters greater than 406.4 mm (16 in.), put the system in its straight position.

### 1.2.4 Wheels

The shape of the wheels allows them to work on the entire diameter range without requiring any adjustments. The wheels are magnetized with polyurethane rolling surface to allow a smooth and steady movement over rough surfaces (Figure 1-3 on page 29).



**WARNING**



Before handling the scanner, observe the following general safety precautions related to its magnetic wheels (see “Replacing Wheels” on page 76 for complete details on wheel safety):

- The magnetic fields around the wheels may affect pacemakers, watches, and other sensitive electronic devices, and anyone relying on such devices must keep a safe distance away from the wheels to avoid the risk of serious injury or death.
  - Magnetic wheels present a risk of finger crushing if fingers are placed between the wheels and a ferromagnetic surface.
  - The magnets are strong and will be attracted to any ferromagnetic surface **WITHOUT** warning, which can cause injury, equipment damage, or malfunction. Ensure that your feet have a solid grip on the floor. Use a rubber carpet when the floor is wet and slippery.
-

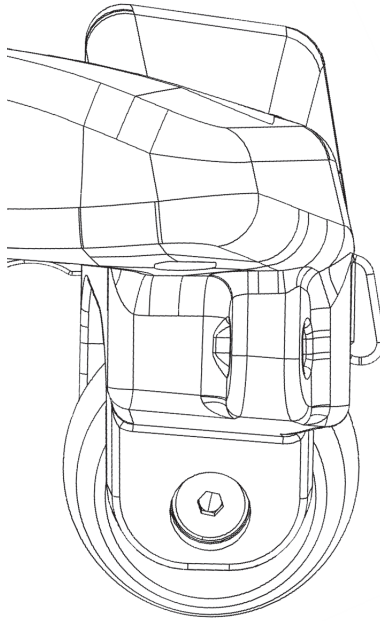

**Figure 1-3 Magnetic wheel**

### **1.2.5 Brake System**

The brake system blocks the wheels to prevent the scanner from moving.

### **1.2.6 Encoder**

A wheel encoder measures the scanner displacement to determine the position on the scan axis (Figure 1-4 on page 30).

The encoder is spring-loaded to ensure that it remains in contact with the inspection surface with adequate pressure and travel for different pipe diameters. The encoder is waterproof and comes with a cable that connects to the ScanDeck™ module.

Although the encoder cannot be connected directly to an instrument but rather through the ScanDeck™ module, its technology is compatible with OmniScan and FOCUS instruments.

**NOTE**

For the OmniScan MX flaw detector, an optional adaptor is required (P/N: U8780329).  
For the TomoScan FOCUS LT acquisition instrument, an optional cable is required (P/N: U8769010).

---

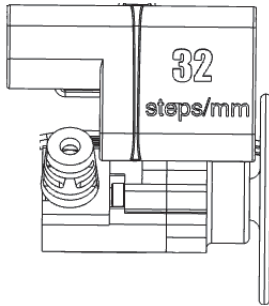

**Figure 1-4 Encoder for measuring scanner position on the surface**

## 1.2.7 Umbilical Attachment

The umbilical can quickly be attached or detached from the scanner using a thumb screw located underneath the frame.

## 1.2.8 Quick-Reference Probe Holder Position Rulers

Rulers are provided on top of the scanner frame bar sections to help position the probe holders at the same distance from the center of the scanner (Figure 1-5 on page 31).

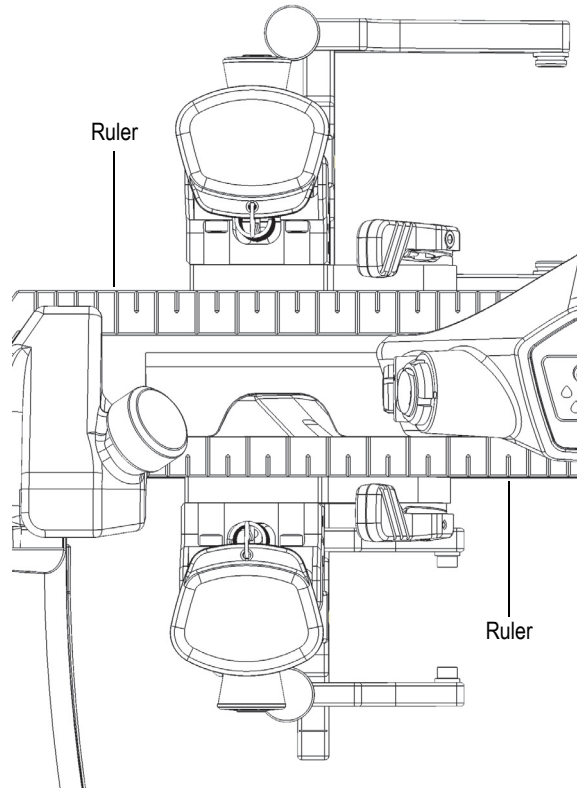

**Figure 1-5 Rulers to help position the probe holder**

### **1.3 ScanDeck™ module**

The ScanDeck™ module contains status indicators and control buttons (Figure 1-6 on page 32) to help the operator during the inspection.



## WARNING



Class 1 laser radiation. The laser of this product is a Class 1 laser under the IEC608251-1 (2014). Class 1 laser products are safe during use, including long-term direct intrabeam viewing, even when exposure occurs while using optical viewing instruments (eye loupe or binoculars).

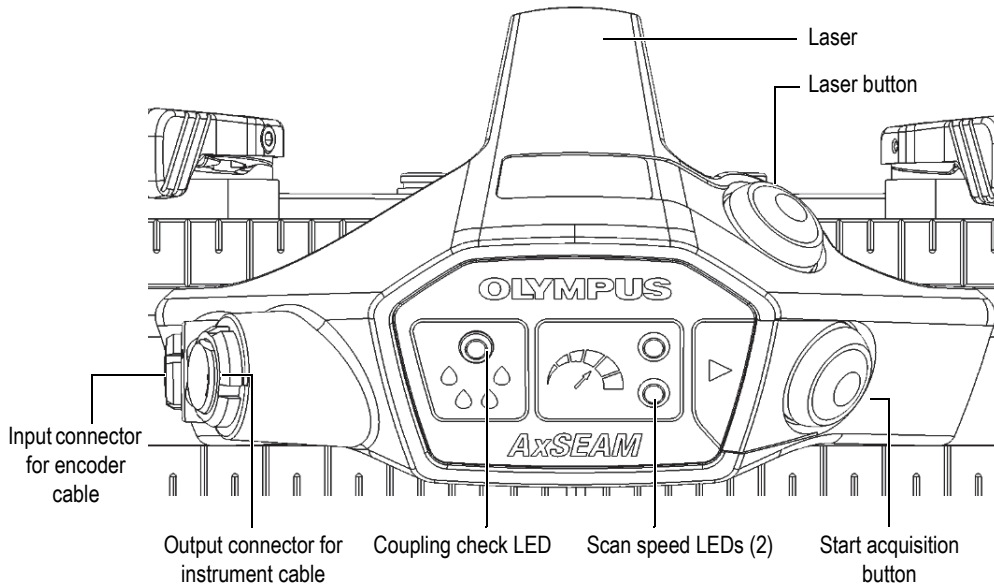

**Figure 1-6 ScanDeck™ module components**

### Coupling check LED

When set up correctly in an OmniScan X3 instrument, a steady blue LED will be on when the coupling between the wedges and the part to be inspected is correct. When coupling is lost, the blue LED will flash. This function is not compatible with the OmniScan MX or MX2 flaw detector. Refer to the *OmniScan X3 User's Manual* for details on this functionality.



### Scan speed LED

When set up correctly on an OmniScan X3 flaw detector, a green light will stay on when the speed of the scanner is inferior to the maximum speed allowed by the instrument. If the scanner speed exceeds the maximum, the green light will turn off and a red LED will flash up to 2 second after the last missed data occurred. This function is not compatible with the OmniScan MX or MX2 flaw detector. Refer to the *OmniScan X3 User's Manual* for details on this functionality.

### Start acquisition button

When set up correctly in an OmniScan flaw detector (all generations using digital input DIN 1), this button is used to remotely clear data and reset the encoder to origin.

### Laser

When the scanner is connected to an OmniScan flaw detector, the laser can be activated to help the operator stay aligned with a weld or reference line with the scanner.

### Laser button

The button is used to start and stop the laser. If the scanner is disconnected from the OmniScan flaw detector while in function, it will remain off even when the scanner is reconnected to the OmniScan.

### Input connector for encoder cable

The encoder cable must be connected at this position.

### Output connector for instrument cable

The cable linking the scanner to the instrument must be connected here.

## 1.4 Probe Holder

The probe holders were developed to improve usability and data quality. All common adjustment operations can be done without using any tools, the pressure applied to the wedge can be easily changed, and the same yoke can be used to hold different wedge sizes.

The probe holder offers increased stiffness for precise and stable probe positioning. The probe holder components are illustrated in Figure 1-7 on page 34.

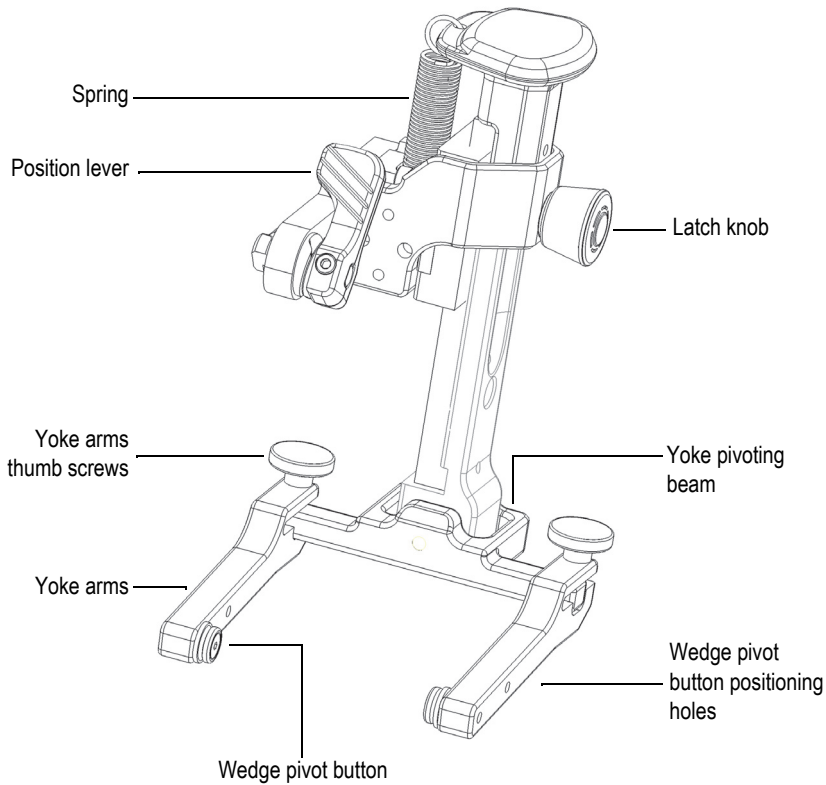

**Figure 1-7 Probe holder components**

### Positioning lever

A quick action lever is used to loosen the probe holder so it can slide on the probe holder mounting rail or be removed from the frame altogether.

### Springs

Three different sets of springs are provided with different spring rates, and they can quickly be changed without tools to adjust the pressure between the wedge and the part for different configurations.

### Latch knob

The latch system is used to hold the probe in a raised position to ease any manipulation of the wedge.

### Yoke arm thumb screw

Used to quickly loosen a yoke arm to remove or install a probe. Can also be used to set the yoke for different wedge widths.

### Wedge pivot buttons

There are two models of wedge pivot buttons. A 8 mm diameter set for phased array probes and a 5 mm diameter set for TOFD or UT transducers as well as DLA probes.

### Wedge button positioning holes

If there is enough room, the wedge pivot button can be positioned closer to the yoke pivoting beam for more stability of the probe during the inspection.

### Yoke arms

Two different yoke arm lengths are provided with the AxSEAM scanner. A longer one for phased array probes and a shorter one for TOFD or UT transducers (Figure 1-8 on page 35, Figure 1-9 on page 36, Figure 1-10 on page 36, and Figure 1-11 on page 37). For yoke dimensions, see “Specifications” on page 99.

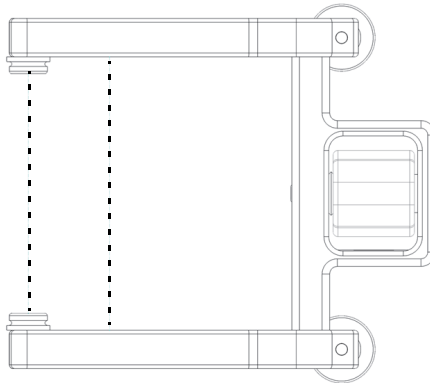

**Figure 1-8 Long yoke with maximum (55 mm) wedge width setting**

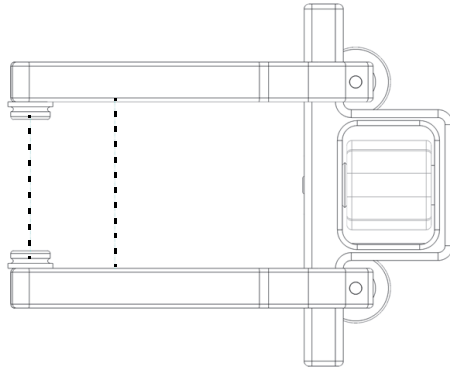

**Figure 1-9 Long yoke with minimum (31.75 mm) wedge width setting**

---

<b>NOTE</b>
-------------

The long yoke has a two-button position as shown by the dotted lines.

---

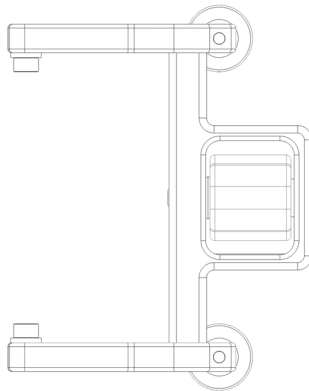

**Figure 1-10 Short yoke with maximum (55 mm) wedge width setting**

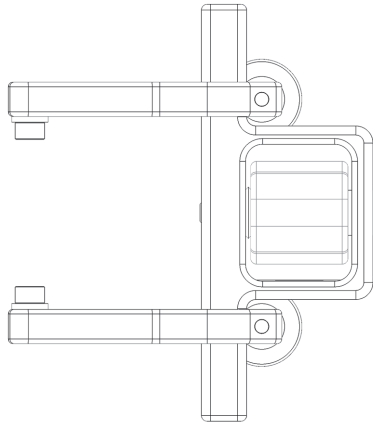

**Figure 1-11 Short yoke with minimum (31.75 mm) wedge width setting**

---

**IMPORTANT**

It is important to ensure that both yoke arms are properly aligned with the center of the yoke pivoting beam. Having unaligned yoke arms could result in the probe flipping during the inspection, compromising data acquisition. For correct and incorrect alignment examples, see Figure 1-12 on page 38 and Figure 1-13 on page 38 respectively.

---

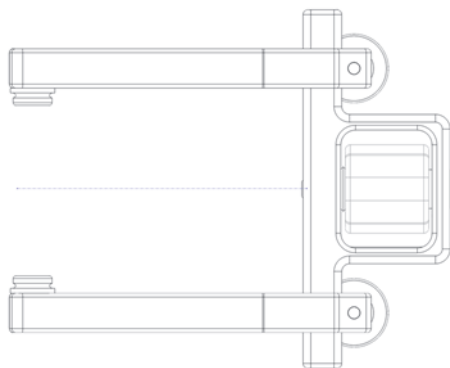

**Figure 1-12 Correct alignment of the yoke arms**

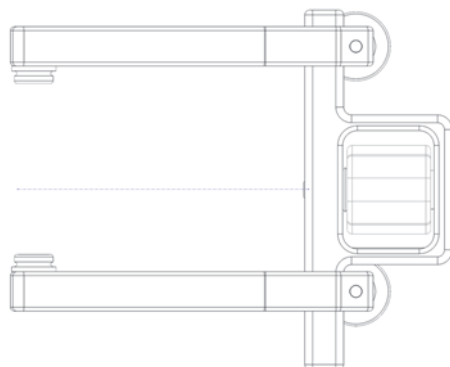

**Figure 1-13 Incorrect alignment of the yoke arms**

---

## 2. Scanner Assembly and Setup

---

The AxSEAM scanner is designed so that part changes and adjustments can be easily carried out.

### 2.1 Changing the Probe Holder Mounting Rail Angle for Longitudinal Scanning

The probe holder mounting rails—and consequently, the probe orientation relative to the surface being inspected—is changed by using the longitudinal scanning pivot system. It is recommended to set the probe holder mounting rails as follows.

- Pipe diameters from 152.4 mm (6 in.) up to 406.4 mm (16 in.): set at the lowest position.
- Pipe diameters from 406.4 mm (16 in.) and up: set at the upper position.

#### To change the probe holder mounting rail angle

1. Turn counterclockwise the knobs at the end of the two front probe holder mounting rails and pull them. When they are loosened enough, the knobs pop out of the threads, remaining attached to the scanner (Figure 2-1 on page 40).

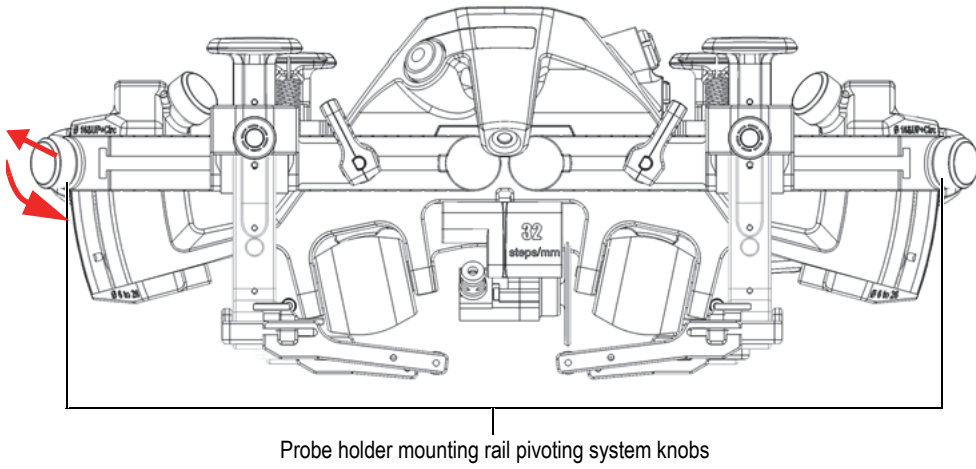

**Figure 2-1 Probe holder mounting rail in upward position**

2. Pivot the two probe holder mounting rails until they reach their travel limits (Figure 2-2 on page 40).

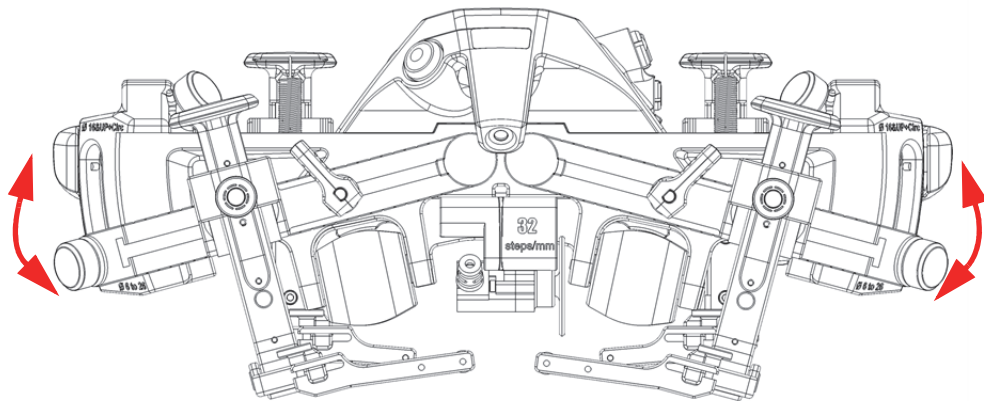

**Figure 2-2 Probe holder mounting rails in downward position**



**NOTE**

Verify that the probe cables are not in contact with the probe holders. In some cases, on pipe diameters that are between 406.4 mm (16 in.) and 660.4 mm (26 in.), the frame pivots may need to be placed at their lowest positions to prevent the cables from coming into contact with the probe holders (Figure 2-12 on page 48).

3. Turn the knobs clockwise to secure the probe holder mounting rails into position.

## 2.2 Changing the Frame Angle for Circumferential Scanning

For the circumferential inspection of pipes with diameters smaller than 16 in. OD, the frame must be pivoted using the pivoting system.

### To change the frame angle for circumferential scanning

1. Turn counterclockwise the two frame pivoting system knobs (Figure 2-3 on page 41).

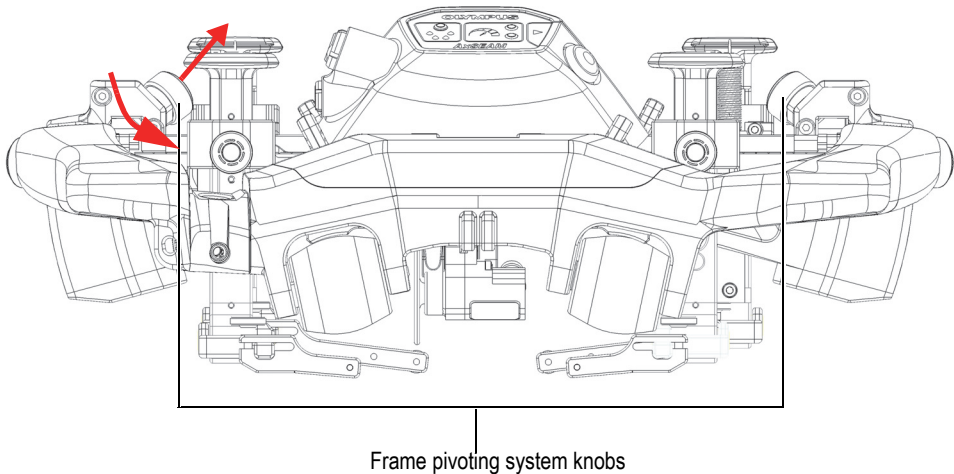

**Figure 2-3 Circumferential scanning adjustment knobs**

When they are loosened enough, the knobs pop out of the threads, remaining attached to the scanner (Figure 2-4 on page 42).

---

<b>NOTE</b>
-------------

Do not try to completely remove the knobs from the scanner.

---

2. Pivot the frame up to the desired position, ensuring that it does not exceed its maximum travel limit until the knobs snap back into the frame (Figure 2-4 on page 42).

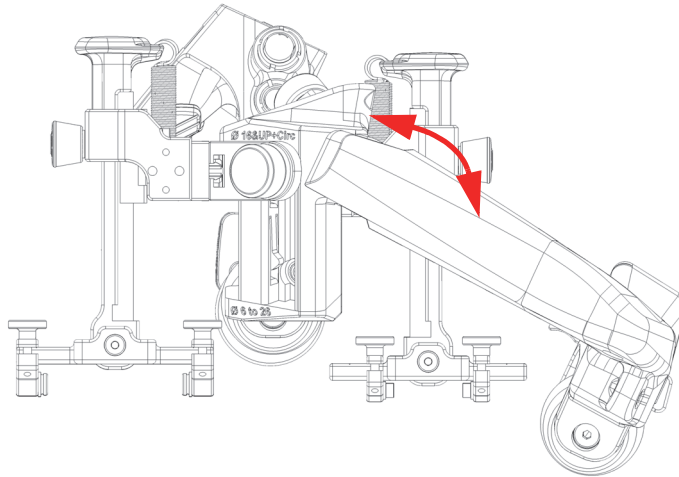

**Figure 2-4 Circumferential frame adjustment in pivoted position for pipes of 406.4 mm (16 in.) OD and lower**

3. Make sure that the two knobs are properly aligned with their threads, then turn them clockwise to lock the scanner in the inclined position.

## 2.3 Installing a Probe Holder on the Scanner

### To install a probe holder on the scanner

1. Using the position lever, align the position of the cam pin so that the flat edges are aligned horizontally (Figure 2-5 on page 43).

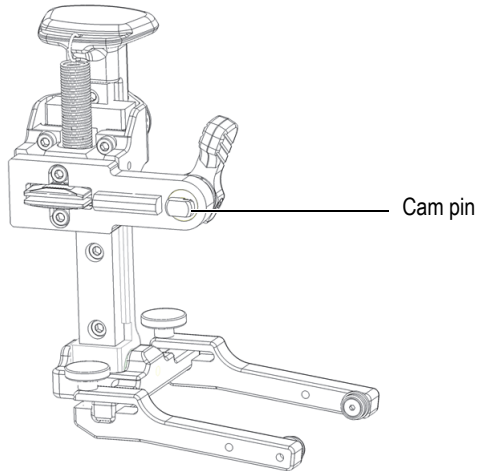

**Figure 2-5 Horizontally aligned flat edges**

2. Align the probe holder with the rail slot, ensuring that both are parallel to each other (Figure 2-6 on page 44).

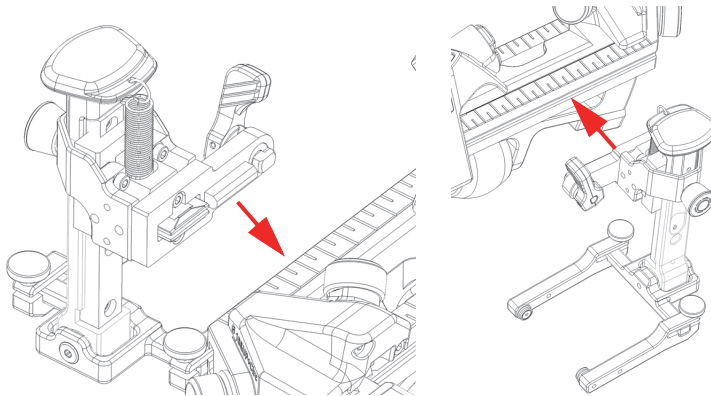

**Figure 2-6 Probe holder alignment with the rail slot**

3. Firmly press the probe holder into the rail slot, making sure that the cam pin stays aligned horizontally (Figure 2-7 on page 44).

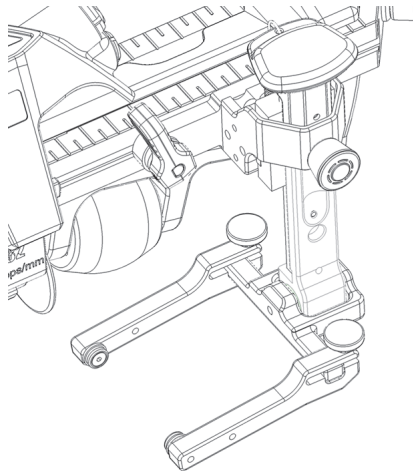

**Figure 2-7 Probe holder inserted into the rail slot**

4. Rotate the position lever clockwise to lock the probe holder into place (Figure 2-8 on page 45).

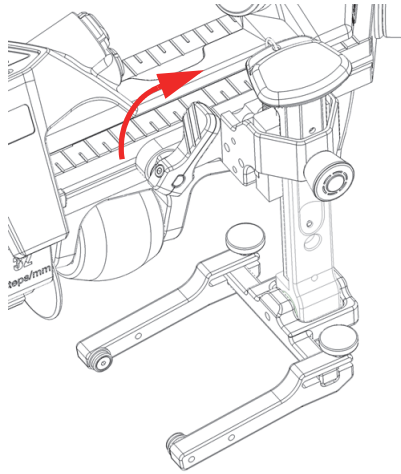

**Figure 2-8 Probe holder secured into place**

5. To remove the probe holder, unlock the position lever, and pull on the probe holder with a slight upward or downward motion until it comes out of the rail.

## 2.4 Sliding the Probe Holder

### To slide the probe holder

1. Turn the position lever counterclockwise to unlock the probe holder (Figure 2-9 on page 46).

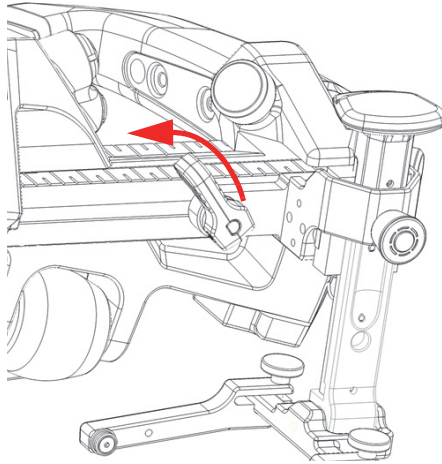

**Figure 2-9 Position lever unlocked**

2. Slide the probe holder to the desired position (Figure 2-10 on page 46).

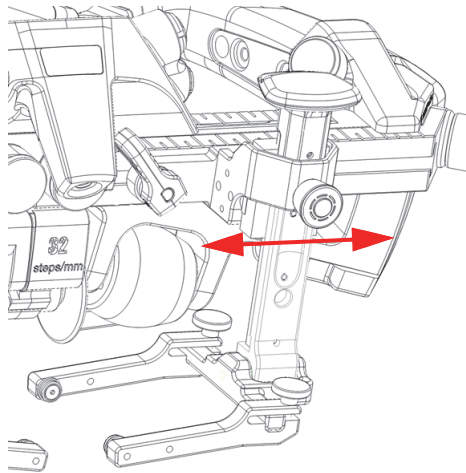

**Figure 2-10 Sliding the probe holder**

**CAUTION**

Risk of product damage. Do not over-tighten the position lever or breakage may occur.

---

3. Turn the position lever clockwise to lock the probe holder into place (Figure 2-11 on page 47).

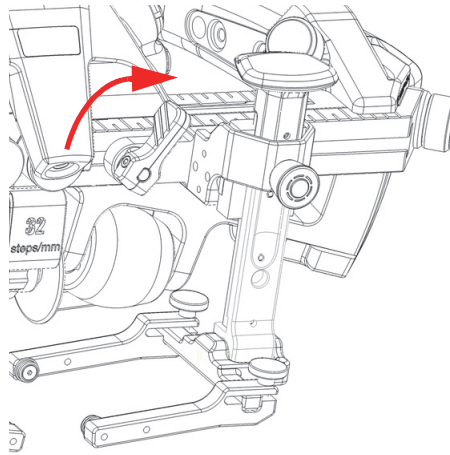
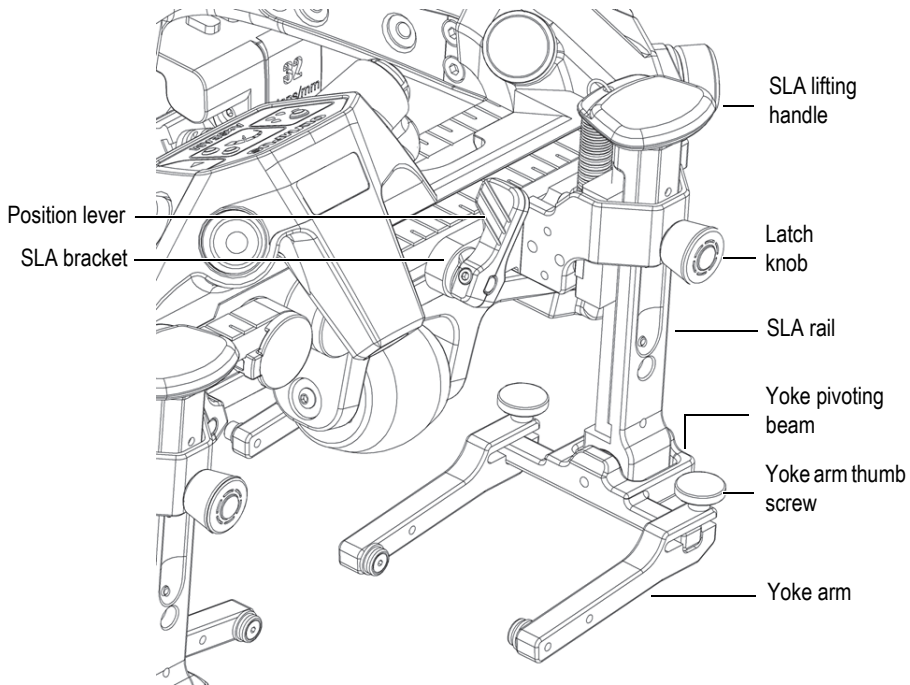

**Figure 2-11 Position lever locked**

## 2.5 Operating the Probe Holders

Ultrasonic transducers and phased array probes are mounted on the scanner through the use of probe holders (Figure 2-12 on page 48).

The position lever mounted on the bracket enables easy positioning of the probe holder along the probe holder mounting rails (Figure 2-12 on page 48).

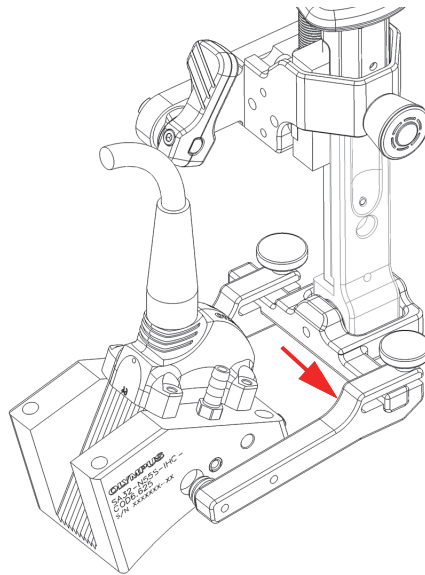

**Figure 2-12 Probe holder assembly parts**

**To install or remove a probe/wedge assembly in the probe holder**

1. Loosen the yoke arm thumb screw, and then slide one of the yoke arms outward to the tip of the yoke pivoting beam. The screw and the arm must stay attached to the probe holder (Figure 2-13 on page 49).





**Figure 2-13 Sliding the yoke arm to the tip of the yoke pivoting beam**

2. Remove the probe/wedge assembly from the yoke.
3. To reinstall a probe/wedge assembly, align the wedge pivot holes with the button of the yoke arm that is not slid out (Figure 2-14 on page 50).

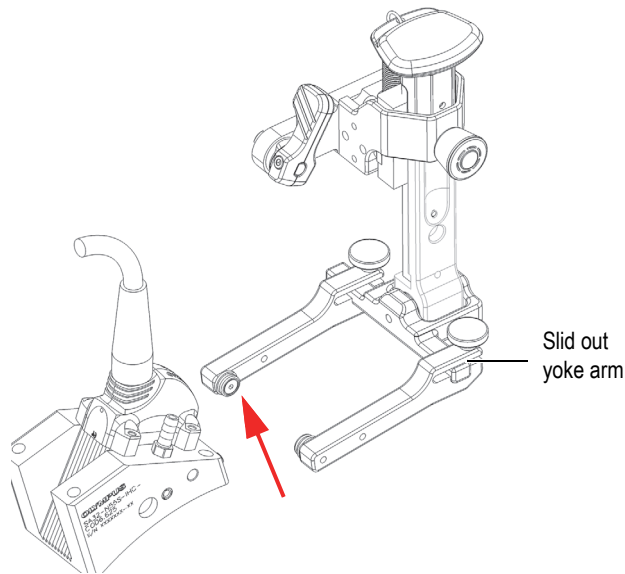

**Figure 2-14** Aligning the wedge pivot hole with the yoke arm button

4. Slide the other yoke arm inward on the yoke pivoting beam making sure that the buttons are well inserted in the wedge holes and that the arms are holding the wedge tight.
5. Tighten the yoke arm thumb screw to secure the yoke arm into place. Make sure that the probe is centered with the yoke pivoting beam.

## 2.6 Using Shims with 40 mm Wide Wedges

For 40 mm wide wedges, shims are available to ensure that both yoke arms are properly aligned and that the wedge is centered.

### To use shims with 40 mm wide wedges

1. Loosen the yoke arm thumb screws, and remove both yoke arms from the yoke pivoting beam.
2. Insert one shim on each side of the yoke pivoting beam (Figure 2-15 on page 51).

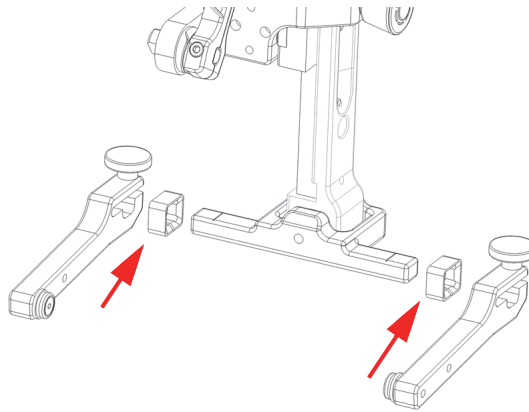

**Figure 2-15 Yoke arms removal and shim insertion**

3. Slide the yoke arms back onto the yoke pivoting beam, and secure them in place with the yoke arm thumb screws (Figure 2-16 on page 51).

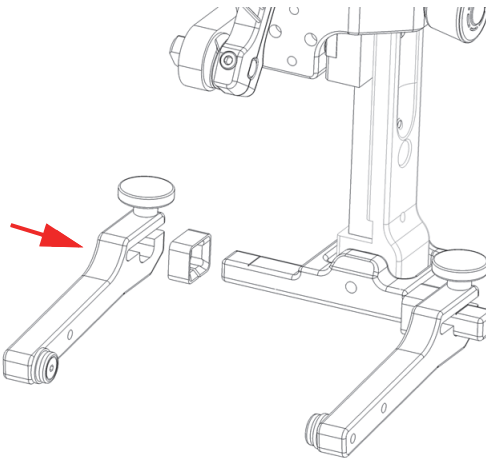

**Figure 2-16 Reinstalling the yoke arms**

## 2.7 Basic Operations on Probes and Wedges

This section covers the basic operations performed on probes and wedges, which include adjusting the carbide wear pins and replacing a phased array probe or wedge.

### 2.7.1 Adjusting the Carbide Wear Pins on Wedges

Wedges are designed to hold a transducer or a phased array probe in order to ensure adequate ultrasonic diffusion through the surface to be inspected, and to direct the couplant flow correctly. To limit wearing of the wedge, carbide wear pins can be inserted at each corner of the contact surface of the wedge (Figure 2-17 on page 52).

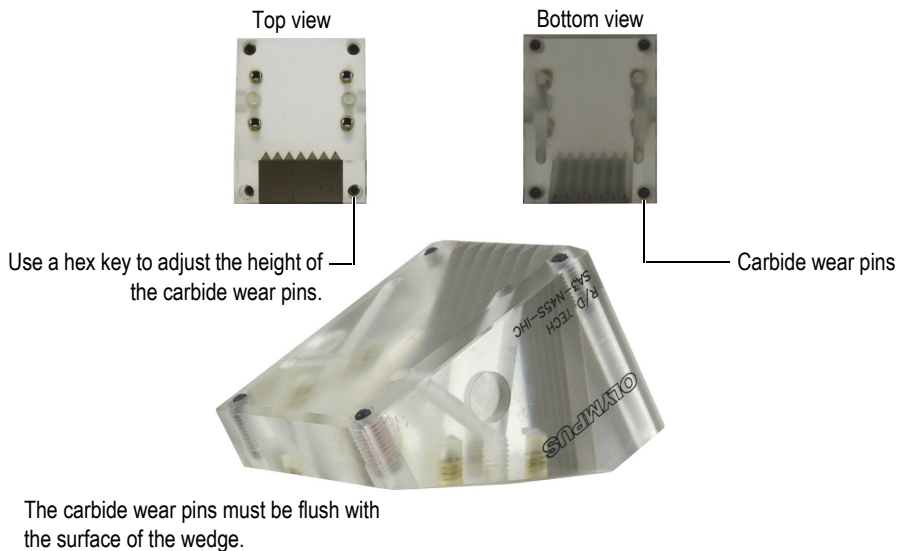

Figure 2-17 Adjusting the wedge's carbide wear pins

#### To adjust the carbide wear pins on a wedge

- ◆ Use a hex key to adjust the height of the carbide wear pins on each installed wedge. Ensure that the top of each pin is flush to the surface of the wedge (Figure 2-17 on page 52).

**IMPORTANT**

A carbide that is screwed too far inside the wedge can cause the wedge to wear faster and unevenly, while a carbide that protrudes too far outside the wedge can contribute to loss of coupling and degraded data. The use of thread-locking fluid is recommended to help maintain the carbide adjustment while scanning.

## 2.7.2 Replacing a Phased Array Probe or a Wedge

### To replace a phased array probe or a wedge

1. Disconnect the couplant tubes from the wedge.
2. Disconnect the probe cable on the instrument.
3. Using a cross-head screwdriver, unscrew the screws that hold the probe on the wedge (either 2 or 4 screws, depending on the model), and then remove the probe from the wedge (Figure 2-18 on page 53).

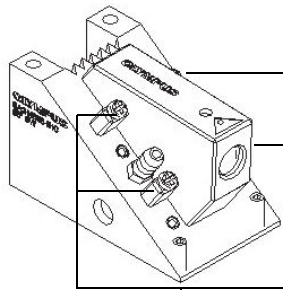

Use a cross-head screwdriver to unscrew the 2 or 4 screws.

**Figure 2-18 Removing the probe from the wedge**

4. Clean the probe surface and the wedge surface to remove any of the old coupling product.
5. Add a generous amount of the new coupling product.

6. Install the new probe onto the wedge.
7. Using the cross-head screwdriver, tighten the screws that hold the probe on the wedge in a cross pattern.

---

**IMPORTANT**

Not tightening the screws using a cross pattern results in the probe being positioned with a slight angle on the wedge and affects the acoustic performance.

---

## 2.8 Flipping a Probe Holder

To flip a probe holder from left to right or vice versa

1. Remove the two screws on the SLA bracket with a 2.5 mm hex key (Figure 2-19 on page 54).

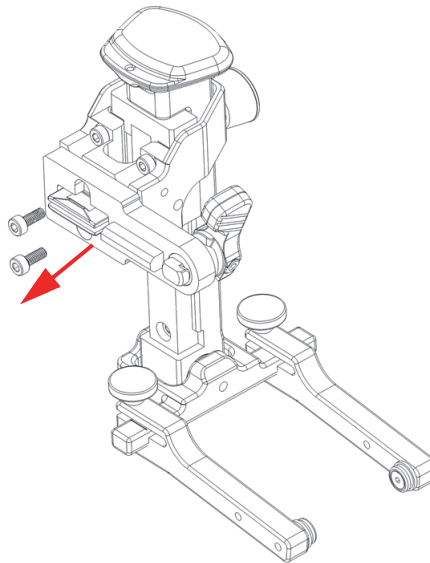

**Figure 2-19 Removal of two screws**

2. Rotate the SLA bracket 180 degrees (Figure 2-20 on page 55).
3. Put the two screws back into place (Figure 2-20 on page 55).

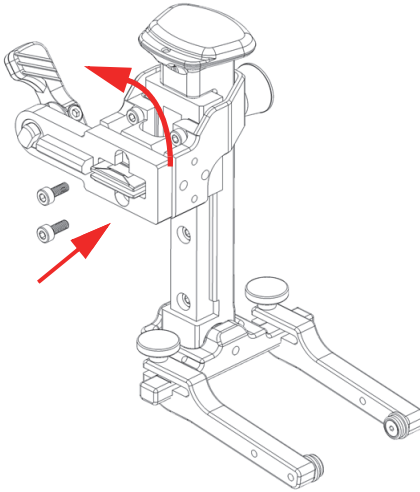

**Figure 2-20 Flipping of the SLA bracket**

4. Remove the screw of the yoke pivoting beam with a 2.5 mm hex key (Figure 2-21 on page 56).

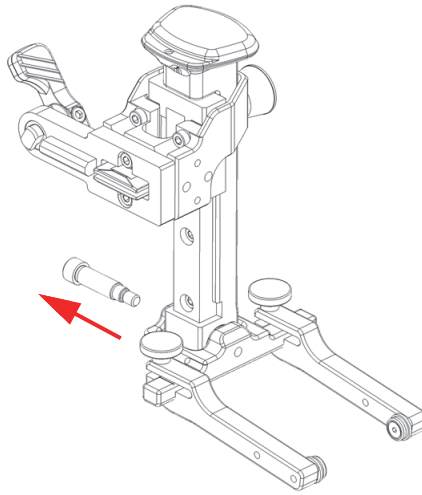

**Figure 2-21 Removal of yoke pivoting beam screw**

5. Slide the SLA rail out of the yoke pivoting beam (Figure 2-22 on page 56).

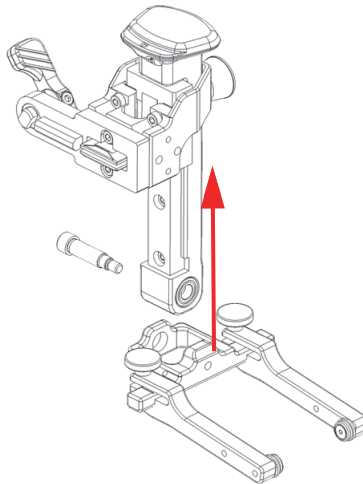

**Figure 2-22 Sliding out the yoke pivoting beam**



6. Rotate the yoke pivoting beam 180 degrees and slide it back into the SLA slider (Figure 2-23 on page 57).

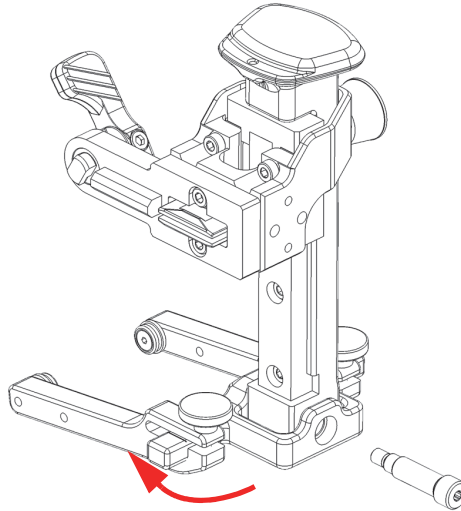

**Figure 2-23 Flipping of the yoke pivoting beam**

7. Reinstall the screw into the yoke pivoting beam (Figure 2-24 on page 58).

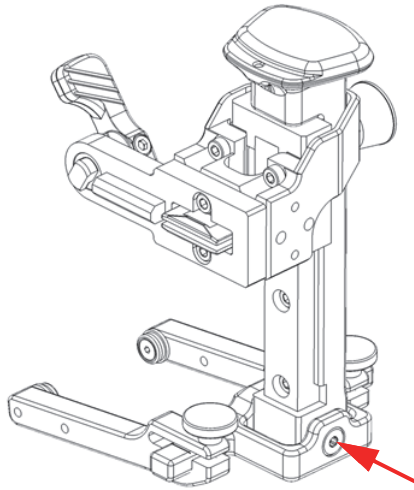
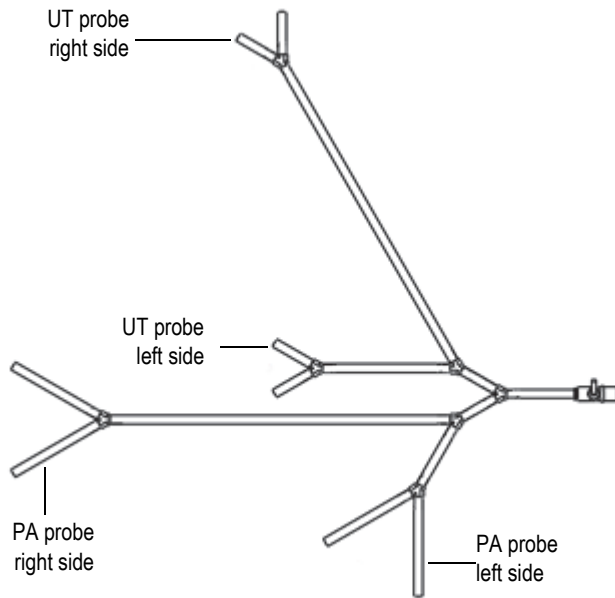

**Figure 2-24 Putting the screw back in**

## **2.9 Connecting Cables and Tubes**

### **To connect cables and tubes**

1. Using the provided water tubing assembly, connect each extremity to the appropriate wedges irrigation system (Figure 2-25 on page 59 and Figure 2-26 on page 60).



**Figure 2-25 Water tubing assembly**

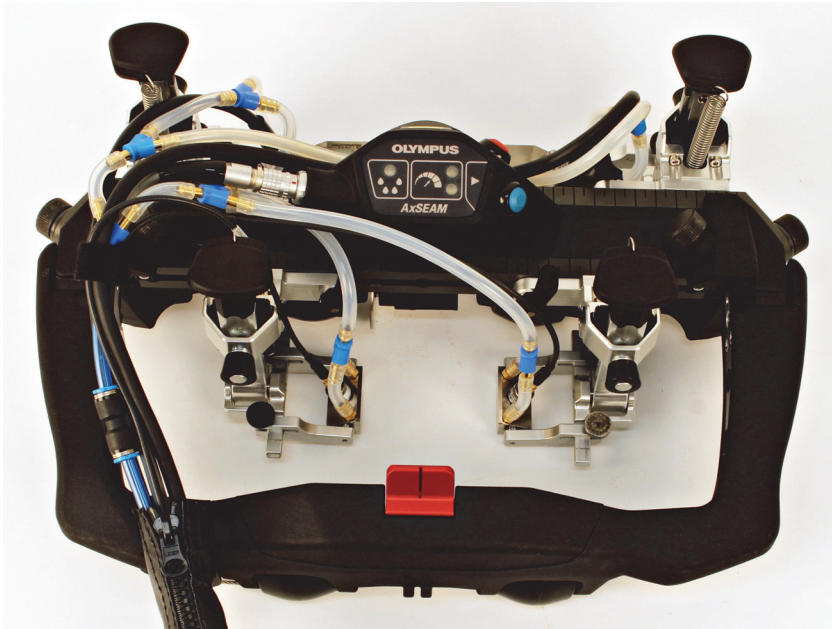

**Figure 2-26 Probe irrigation system**

2. Connect the water valve to the water inlet tubing.
3. Connect the electronic cables to the ScanDeck™ module.
4. Guide all the water, probe, and electronic cables so they run together into the zipper cable management. Make sure that you reserve extra cable length for probe offset adjustment and frame pivoting movements.
5. Close the zipper completely (Figure 2-27 on page 61).



**Figure 2-27 Cable management – zipper**

## **2.10 Connecting the Scanner**

### **To connect the scanner**

1. Make sure that the encoder is connected to the ScanDeck™ module.
2. Make sure that the scanner cable is connected to the ScanDeck™ module.
3. Connect the splitter to the OmniScan PA connector.
4. Connect the two phased array probes to the splitter.
5. Connect the UT probes to the OmniScan UT connectors.
6. Connect the scanner cable to the OmniScan encoder connector (IOIO symbol) (Figure 2-28 on page 62).



**Figure 2-28 Scanner and OmniScan connected**

## **2.11 Choosing and Changing the Probe Holder Spring Tension**

The springs that are provided for the probe holders have three different spring rate: standard, medium, and strong.

The standard spring are the ones with the least tension but should be able to accommodate most situations. However, there might be situations where the standard spring would not put enough pressure on the probe, resulting in less accurate readings. Such situations could arise when the pipe diameter falls between 254 mm (10 in.) and 406.4 mm (16 in.) in circumferential scanning or when the scanner is used with heavy probes while upside down. Note that there might be other scenarios where a stronger spring could be favored.

The springs are color-coded for quick identification:

- The standard spring has a blue mark on the tip.
- The medium spring has no mark.

- The strong spring has a red mark on the tip.

---

**NOTE**

Although changing the springs can be done without tools, it is preferred to use a pair of long-nose pliers to change the springs.

---

**WARNING**

Use caution when removing or replacing springs under tension as this could cause potential damage or serious personal injury. It is recommended to wear safety glasses when changing the springs.

---

### To choose and change the probe holder spring tension

1. Using a pair of long-nose pliers, remove the bottom part of the spring from the hole of the SLA bracket (Figure 2-29 on page 63).

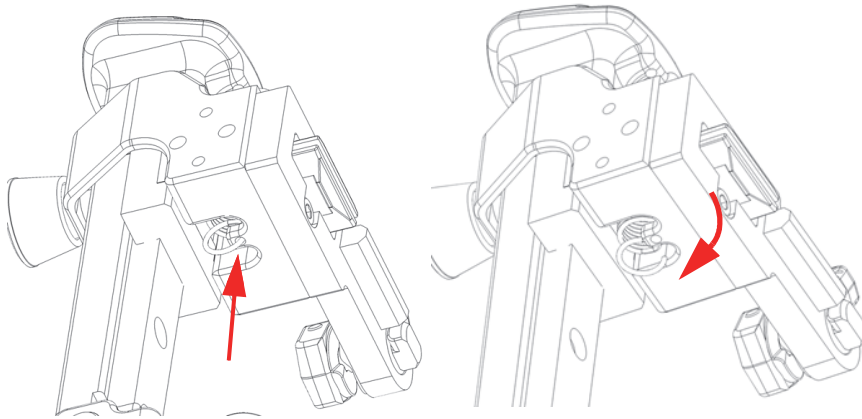

**Figure 2-29 Removal of the spring from the fixation hole**

2. Remove the top part of the spring from the hole in the SLA lift handle (Figure 2-30 on page 64).

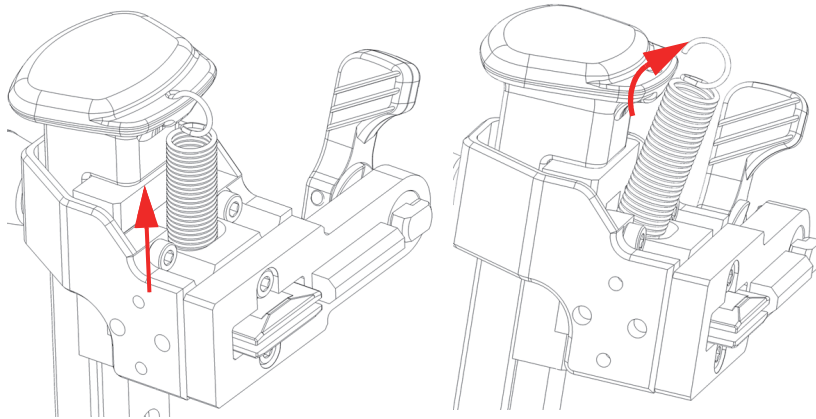

**Figure 2-30 Removal of the spring**

3. To reinstall a spring, perform step 1 and step 2 in reverse.



---

## 3. Preparing the Scanner for an Inspection

---

Several connections and adjustments must be made to prepare the AxSEAM scanner for an inspection.

### 3.1 Attaching the Lanyard

Make sure that you observe the following precautions when handling the AxSEAM scanner.



#### **CAUTION**

Before installing the AxSEAM scanner on a surface, make sure that the surface is clean and free of debris. Any particles preventing free movement of the scanner should be removed or it could result in minor or moderate personal injury or material damage.

---



#### **WARNING**

To prevent injury and equipment damage when operating the AxSEAM scanner at heights 2 meters or higher above ground or floor level, secure it with a lanyard that is held taut (see attachment point in Figure 3-1 on page 66). Wear appropriate safety shoes that protect your feet in case you accidentally drop the unit during handling. Also ensure the inspection surface is free of rust, debris, or obstructions, and is continuously ferromagnetic so that the magnetic wheels remain adhered to the surface.

---

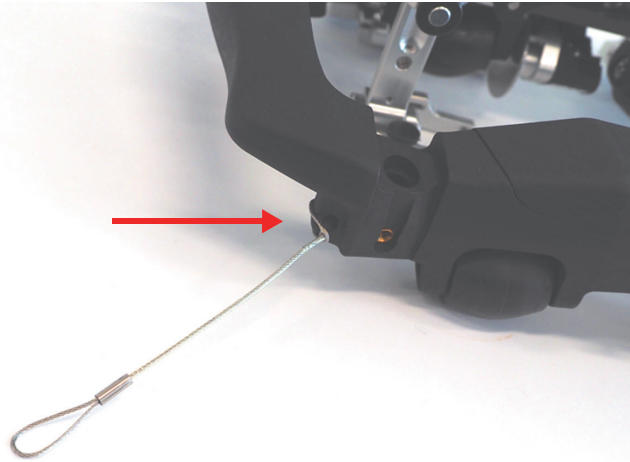

**Figure 3-1 Lanyard attachment point**

## **3.2 Connecting to the Water Pump**

### **To connect to the water pump**

- ◆ Connect the water tubing to the manual or electrical water pump.

## **3.3 Installing the Scanner on the Pipe**

### **To install the scanner on the pipe**

1. Configure the scanner frame for the longitudinal or circumferential position depending on the inspection you need to perform, using the appropriate frame adjustment knobs. For more details, see “Changing the Probe Holder Mounting Rail Angle for Longitudinal Scanning” on page 39 and “Changing the Frame Angle for Circumferential Scanning” on page 41.
  - a) To change the frame configuration, unscrew the two knobs until they pop out (the knobs stay attached to the scanner).
  - b) Choose the frame position according to the part configuration. For more details, see “Changing the Probe Holder Mounting Rail Angle for



## 3.4 Adjusting the Probe Separation Distance

---



### WARNING



Class 1 laser radiation. The laser of this product is a Class 1 laser under the IEC60825-1 (2014). Class 1 laser products are safe during use, including long-term direct intrabeam viewing, even when exposure occurs while using optical viewing instruments (eye loupe or binoculars).

---

### To adjust the probe separation distance

1. Make sure that the magnetic ruler is on the pipe with its zero position aligned with the center of the weld and positioned under the probes to be adjusted.
2. Align the scanner laser light with the zero on the ruler.
3. With the probes in contact with the ruler (probe holder latch released), turn the probe holder positioning lever counterclockwise to unlock it.
4. Slide the probe holder left or right to set the correct probe offset.
5. Turn the probe holder positioning lever clockwise to lock it in place.
6. Repeat for the other probes.
7. Pull up on all probe holders so the probes are latched in their upper position.
8. Roll the scanner until the second pair of probes are over the ruler.
9. Release the probe holders so the wedge comes in contact with the ruler.
10. Remove the ruler from the part.

---

## 4. Operating the AxSEAM Scanner

---

The AxSEAM scanner is designed to be used manually. It is simple to operate.

### 4.1 Using the Brake System

To use the brake system



#### **CAUTION**

The brake may not be sufficient to keep the scanner in a fixed position in some configurations. Always secure the scanner using the lanyard to prevent injuries.

---

- To activate the brake, put the rear red brake lever in the upper position (Figure 4-1 on page 70).

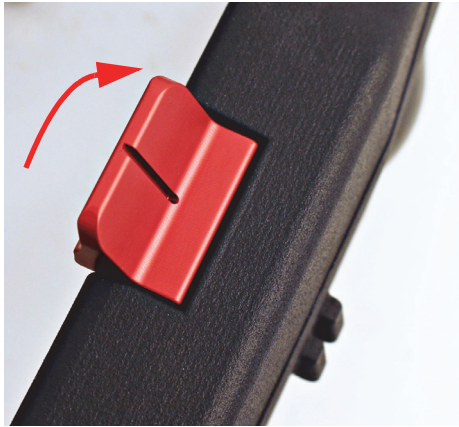

**Figure 4-1 Brake lever activated**

- To deactivate the brake, put the red brake lever in the lowest position (Figure 4-2 on page 70).

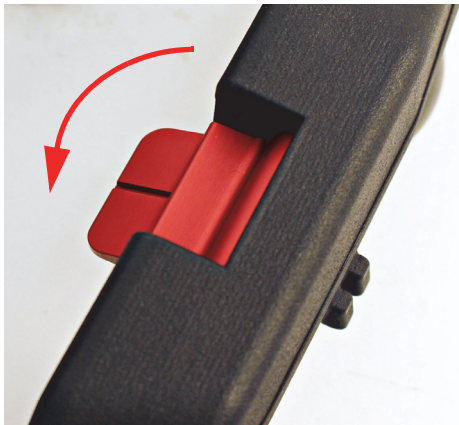

**Figure 4-2 Brake lever deactivated**

## 4.2 Working with the ScanDeck™ module's Feedback

When connected to an OmniScan X3 instrument, the ScanDeck™ module can provide useful feedback information to help you perform the inspection without having to look at the instrument. For details on how to set up the OmniScan instrument, refer to the *OmniScan MX, MX1, and MX2 User's Manual* and *OmniScan X3 User's Manual*.

### 4.2.1 Coupling Check

When set up correctly in an OmniScan X3 instrument, a steady blue LED (Figure 1-6 on page 32) will be on when the coupling between the wedges and the part is correct. When coupling is lost, the blue LED will flash. In such case, the couplant feed should be increased or the scan speed reduced. The scanner should be moved back and the last section be scanned again.

### 4.2.2 Speed Check

When set up correctly in an OmniScan X3 instrument, a green light (Figure 1-6 on page 32) will stay on when the speed of the scanner is inferior to the maximum speed allowed by the instrument. If the scanner speed exceeds the maximum, the green light will turn off and a red LED will flash for up to 2 seconds after the missed data occurred. In such case, the scanner should be moved back and the last section be scanned again at a lower speed.

### 4.2.3 Laser Button

Pushing the laser button (Figure 1-6 on page 32) on the ScanDeck™ module turns on the laser light guide. Pushing the button again turns off the laser.



**WARNING**



Class 1 laser radiation. The laser of this product is a Class 1 laser under the IEC60825-1 (2014). Class 1 laser products are safe during use, including long-term direct intrabeam viewing, even when exposure occurs while using optical viewing instruments (eye loupe or binoculars).

---

---

**NOTE**

If the scanner is disconnected from the OmniScan instrument while the laser light is on, you will have to push the button to turn it on again when the scanner is reconnected to the instrument.

---

## 4.2.4 Start Acquisition Button

After the scanner is set up correctly with any OmniScan instrument simply push the start acquisition button (Figure 1-6 on page 32) to erase all data and set the encoder position to zero.

## 4.3 Operating the Scanner

### To operate the scanner

1. Verify that the probe holders are not in the upper (latched) position and that the wedges are in contact with the part and that their pressure on the surface is good.
2. Verify that the probes are well centered within their yoke as indicated in Figure 1-12 on page 38 and Figure 1-13 on page 38. An offset probe can result in the probe flipping during the scan.



**CAUTION**

In order to prevent human injury and/or equipment damage, all carbide wear pins should be flush with the wedge surface (Figure 2-17 on page 52).

---

3. Make sure that the probe cables are not conflicting with the probe holders.
4. Deactivate the brake system lever.
5. Push on the blue button to start the acquisition on the OmniScan instrument.



---

**NOTE**

Verify that the encoder is correctly set up in the OmniScan instrument and that the encoder value is increasing when you are rolling the scanner forward.

---



---

## 5. Maintenance

---

This chapter deals with the basic maintenance that an operator can perform on the AxSEAM scanner. The maintenance operations explained as follows helps keep the product in good physical and working condition. The AxSEAM scanner is designed so it requires only a minimum of maintenance. This chapter covers preventive maintenance and unit cleaning.

As the AxSEAM scanner has few moving parts, it does not require preventive maintenance. A regular inspection of the product is recommended to ensure that the AxSEAM scanner functions correctly.

### 5.1 Cleaning the Scanner

The AxSEAM scanner's external surfaces can be cleaned when needed. This section provides the procedure for the appropriate cleaning of the product.

#### To clean the scanner



#### **CAUTION**

During cleaning, the cables must remain connected to the scanner's connectors to uphold the waterproof rating (IP57) and to avoid any equipment damage.

---

---

**IMPORTANT**

Do not use abrasive products or powerful solvents that could damage the finish.

---

1. Disconnect all cables that are connected to the OmniScan instrument.
2. Clean the housing with a soft cloth to bring the scanner back to its original finish.
3. Use a damp cloth with a soft, soapy solution to remove persistent stains.

## 5.2 Replacing Wheels

---



**WARNING**



To avoid injury, be careful when handling the magnetic wheels; the magnetic pull of the wheels is strong and could pinch your finger—for example, between two wheels, or between a wheel and a steel surface.

---

### To replace a wheel

1. Use a hex key to remove the small screws while holding the large screw with another hex key (Figure 5-1 on page 77).

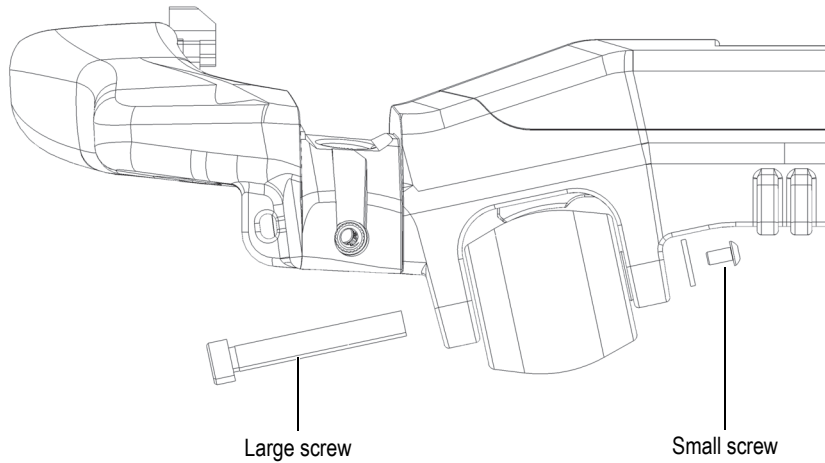

**Figure 5-1 Screw removal**

2. Remove the wheel and pay attention to the bushing inside, which may fall out (Figure 5-2 on page 78).
3. Before installing the new wheel, make sure that the bearings are properly seated on each side, that the bushing is inserted in the center-most hole, and that the washer is in the small screw as indicated in Figure 5-2 on page 78.

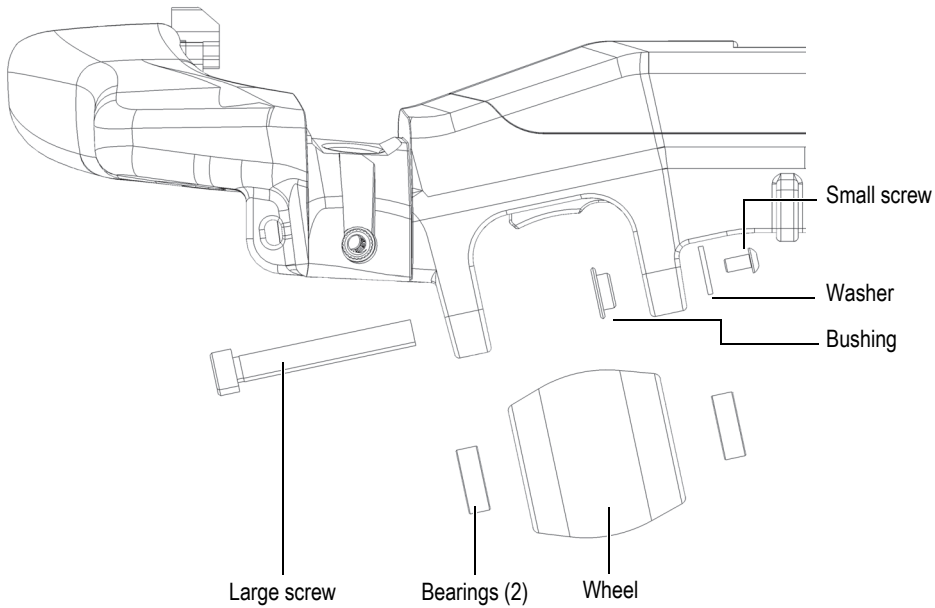

**Figure 5-2 Wheel removal – parts**

---

**NOTE**

You must ensure that the bushing is held in place before inserting the new wheel.

---

---

**IMPORTANT**

When reassembling the wheel, do not forget to insert the washer that goes between the small screw and the wheel frame.

---

**NOTE**

If one of the wheels stops functioning correctly, it is recommended that all four wheels be replaced. Depending on how much the wheels have worn, replacing only one wheel could hinder the smooth motion of the scanner.

---

### 5.3 Removing the Yoke Pivoting Beam

Between the yoke pivoting beam and the SLA rail there are two bearings and a sleeve. If you need to perform maintenance on these parts, they can be separated from each other to give you better access. To do so, follow the procedure to remove the yoke pivoting beam.

---

**NOTE**

This procedure is also part of the procedure “Flipping a Probe Holder” on page 54.

---

#### To remove the yoke pivoting beam

1. Using a 2.5 mm hex key, unscrew and remove the screw located at the back of the yoke pivoting beam (Figure 5-3 on page 80).

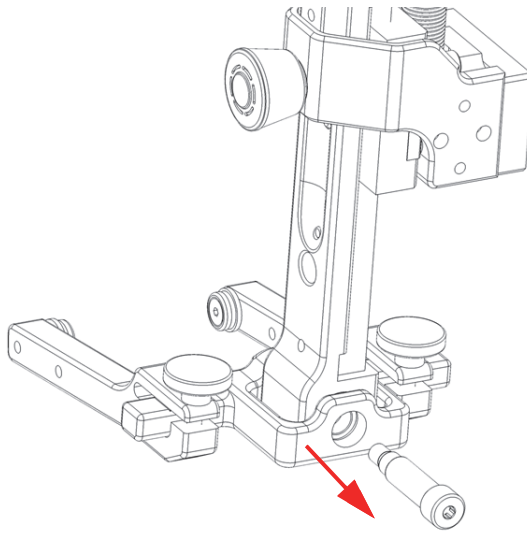

**Figure 5-3 Removal of the rear screw**

2. Slide the SLA rail out off the yoke pivoting beam (Figure 5-4 on page 81).



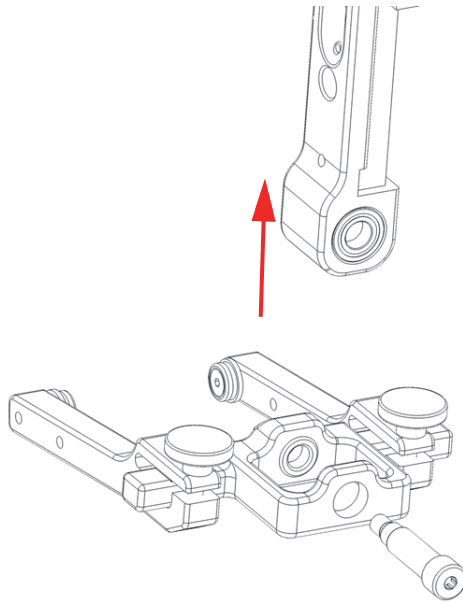

**Figure 5-4 Removal of the SLA rail**

3. Unscrew both yoke arm thumb screws on the left and right yokes and slide the yoke arms out of the yoke pivoting beam (Figure 5-5 on page 82).

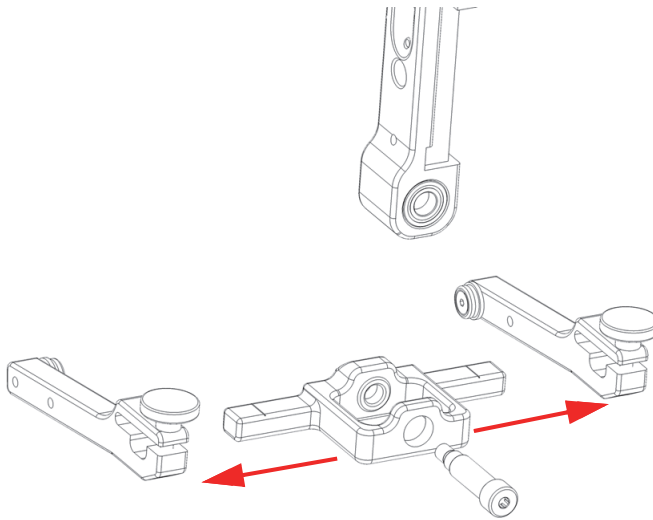

**Figure 5-5 Sliding of the yoke arms**

4. To reassemble the yoke pivoting beam, proceed with these instructions in reverse order.

---

## 6. Spare Parts

---

This chapter presents exploded views and lists of spare parts for the AxSEAM scanner.

To order accessories or replacement parts for your AxSEAM scanner, contact Evident.

## 6.1 Top Assembly

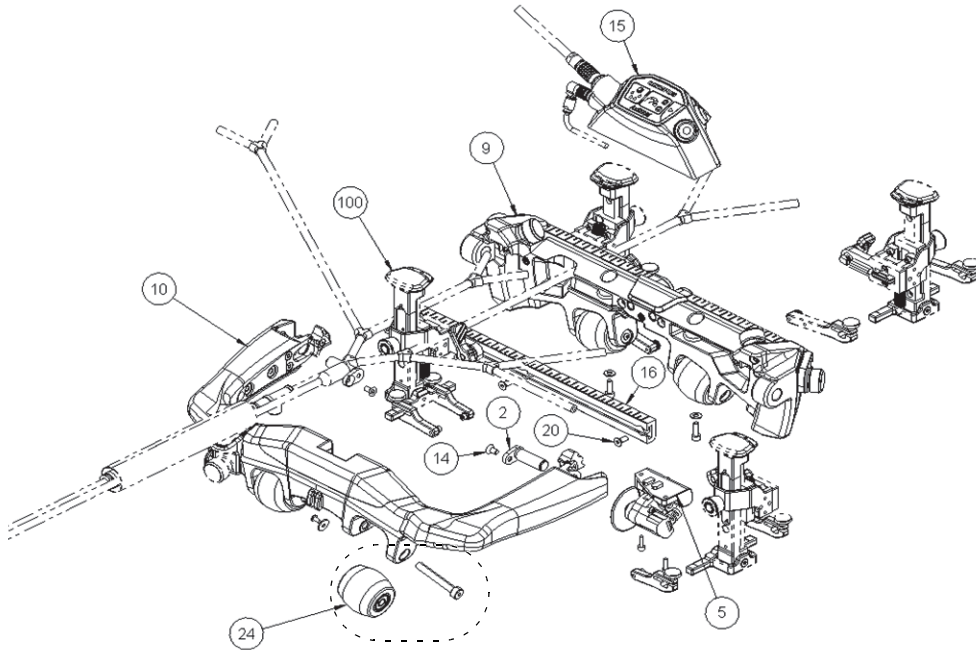

Figure 6-1 Top assembly exploded view

Table 1 Top assembly spare parts

Drawing number	Quantity <sup>a</sup>	Part number	Description
2	2	Q8301791	Pin pivot circumferential
5	1	Q8301792	Encoder complete assembly
14	2	Q8301793	Screw M4 × 8 mm hex flat stain
15	1	Q8301794	Module guidance assembly
16	1	Q8301795	Rail

**Table 1 Top assembly spare parts (continued)**

Drawing number	Quantity <sup>a</sup>	Part number	Description
20	3	Q8301796	Screw M4 × 10 mm hex flat stain
24	4	Q8301797 Q8301798	Magnetic wheel assembly kit, qty 1 Magnetic wheel assembly kit, qty 4
100	4	Q8301799 Q8301800 Q8301801 Q8301802	-Complete probe holder right PA 38–55 mm -Complete probe holder right PA left 38–55 mm -Complete probe holder right TOFD 30 mm -Complete probe holder left TOFD 30 mm
N/A	1	Q8301807	Magnetic ruler
N/A	1	Q8301788 Q8301789	Scanner cable 5 m Scanner cable 10 m
N/A	1	Q8301808	Basic spare part kit

- a. This number represents the typical quantity initially included with your scanner package.

## 6.2 Magnetic Wheel

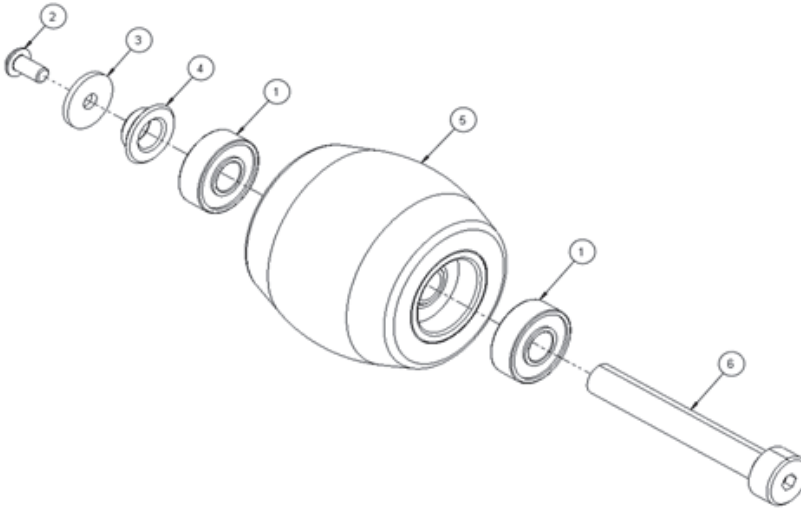

Figure 6-2 Magnetic wheel exploded view – Q8301797

Table 2 Magnetic wheel spare parts

Drawing number	Quantity <sup>a</sup>	Part number	Description
1	2	Q8301462	Bearing 6.0 × 5.0
2	1	Q8301428	Socket button head cap M3.0 × 0.5 × 6.0
3	1	Q8301427	Flat washer #4, M3
4	1	Q8301463	Bushing flange, ID 6.0 × 8.0 × 4.0
5	1	Q8301805	Magnetic wheel
6	1	Q8301806	Shoulder 6.0 × 42.0 × M3.0 int threaded

- a. This number represents the typical quantity initially included with your scanner package.

## 6.3 Encoder

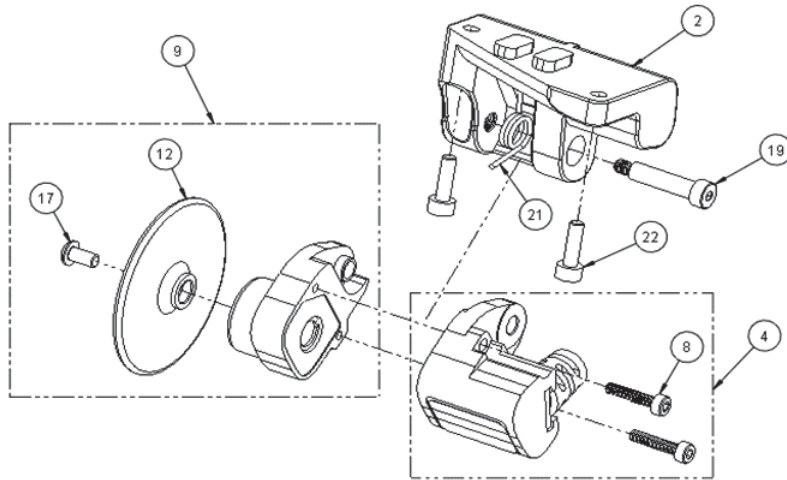

Figure 6-3 Encoder exploded view

Table 3 Encoder spare parts

Drawing number	Quantity <sup>a</sup>	Part number	Description
2	1	Q8301730	Fixation encoder
4	1	Q8301732	Casing encoder electronic
8	2	Q0200585	Screw socket hex M2.5 × 0.45 × 12
9	1	Q8301729	Encoder bearing assembly with wheel
12	1	Q8301728	Wheel encoder
17	1	Q8301428	Socket button head cap screw
19	1	Q8301731	Screw M3-0.5 shoulder Ø4 ×16 mm hex
21	1	Q8301768	Spring torsion 90 deg 0.309 in. OD
22	2	U8908544	Screw M3 ×10 mm stain hex socket cap

- a. This number represents the typical quantity initially included with your scanner package.

## 6.4 Probe Holder

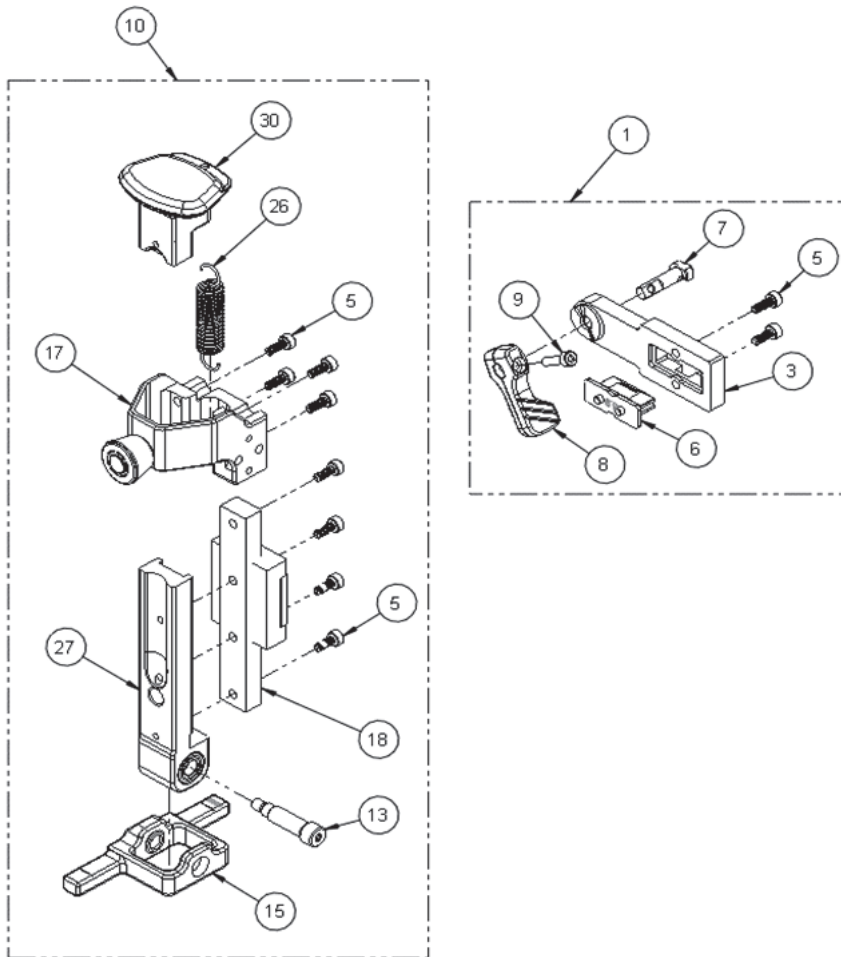

Figure 6-4 Probe holder exploded view



**Table 4 Probe holder spare parts**

Drawing number	Quantity <sup>a</sup>	Part number	Description
1	1	Q8301780	Bracket SLA to rail assembly
3	1	Q8301777	Bracket SLA to rail
5	10	Q8301772	Screw socket head ss M3 × 0.5 mm, 8 mm
6	1	Q8301779	Clip sla to rail
7	1	Q8301778	Pin probe holder fixation
8	1	Q8301776	Knob holder fixation
9	1	Q8300195	Screw, hex, M3 × 12 mm stain
10	1	Q8301781 Q8301782	SLA PA left assembly, does not include arms and rail fixation. SLA PA right assembly, does not include arms and rail fixation.
13	1	Q8301774	Shaft yoke
15	1	Q8301775	Arm center 31.75–55 mm
17	1	Q8301766	Plunger and housing assembly for SLA
18	1	Q8301773	Rail and bearing assembly
26	1	Q8301770 Q8301769 Q8301771	-Spring standard (soft) tension, kit of 10 pieces (blue mark) -Spring medium tension, kit of 10 pieces (no color) -Spring strong tension, kit of 10 pieces (red mark)
27	1	Q8301765	Pivot and bearings assembly for SLA
30	1	Q8301767	Knob SLA

- a. This number represents the typical quantity initially included with your scanner package.

## 6.5 TOFD Yoke Arm

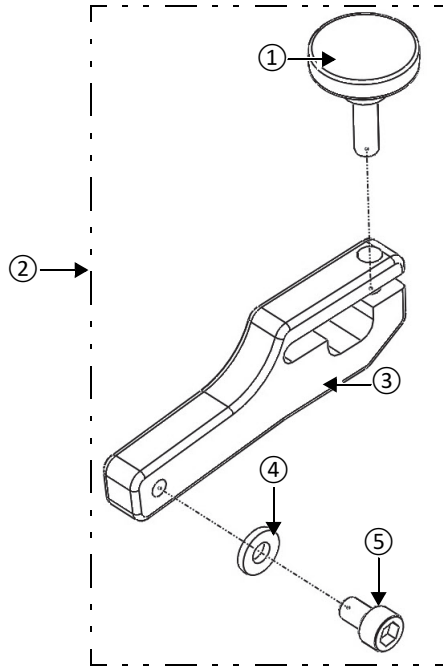

Figure 6-5 TOFD yoke arm exploded view

Table 5 TOFD yoke arm spare parts

Drawing number	Quantity <sup>a</sup>	Part number	Description
1	1	Q8301733	Thumb screw M3 × 10 mm raised
2	1	Q8301734	-Yoke arm 30 mm right assembly
	1	Q8301735	-Yoke arm 30 mm left assembly
	N/A	Q7750196	-Pair of yoke arms 30 mm left and right assemblies
3	1	Q8301735	Yoke arm 30 mm
4	1	Q7750196	Yoke spacer 0.040

**Table 5 TOFD yoke arm spare parts (continued)**

Drawing number	Quantity <sup>a</sup>	Part number	Description
5	1	U8770530	Probe screw pivot

- a. This number represents the typical quantity initially included with your scanner package.

## 6.6 Phased Array Yoke Arm

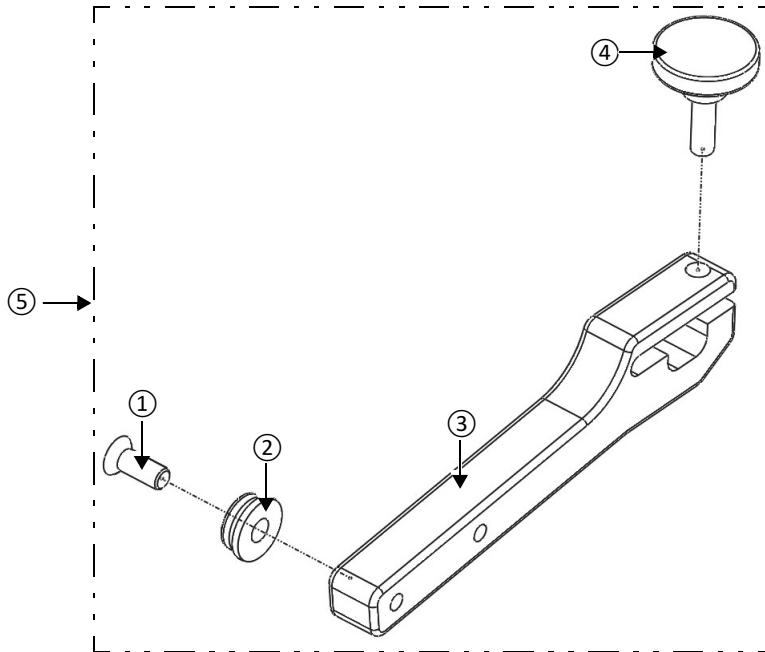
**Figure 6-6 Phased array yoke arm exploded view**

**Table 6 Phased array yoke arm spare parts**

Drawing number	Quantity <sup>a</sup>	Part number	Description
1	1	U8830239	Screw M3 × .5 x 8 fh skt cap 18-8ss
2	1	U8721914	Ø7.8 mm wedge pivot
3	1	Q8301737	Yoke arm 38–55 mm
4	1	Q8301733	Thumb screw M3 × 10 mm raised
5	1	Q8301738	-Yoke arm 38–55 mm left assembly
	1	Q8301739	-Yoke arm 38–55 mm right assembly
	N/A	Q7750197	-Pair of yoke arms 38–55 mm left and right assemblies

a. This number represents the typical quantity initially included with your scanner package.

## 6.7 Cable Management

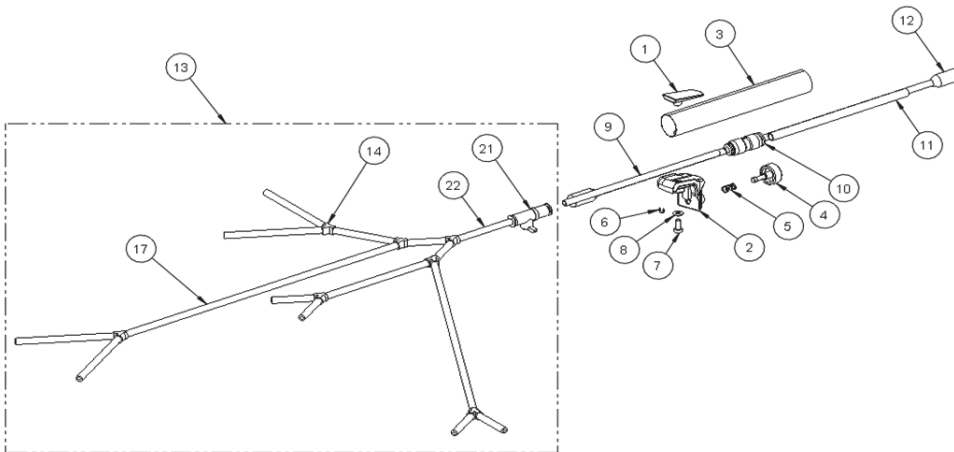

**Figure 6-7 Cables management exploded view**

**Table 7 Cable management spare parts**

<b>Drawing number</b>	<b>Quantity<sup>a</sup></b>	<b>Part number</b>	<b>Description</b>
1	1	Q8301783	Clamp cable sleeve
2	1	Q8301784	Holder sleeve frame
3	1	Q8301785 Q8301786	Cable management sleeve 5 m Cable management sleeve 10 m
4	1	Q8301762	Screw thumb circumferential pivot
5	1	Q8301763	Spring comp. OD 0.25 lenght 0.47
6	1	Q8301764	Ring retaining ext low clearance 4 mm
7	1	Q8301787	Screw M4 × 10 mm hex head stain
8	1	U8908516	Washer flat M4 stain
9	20	U8902320	Tubing ID-4 mm OD-6 mm blue-trans
10	1	U8902319	QS-8-6 push-in reducing
11	0.5	U8902318	Tubing id-5 mm od-8 mm blue
12	1	Q8301788 Q8301789	Cable LEMO M-M 1K.316 to 1T.310 5 m Cable LEMO M-M 1K.316 to 1T.310 10 m
13	1	Q8301790	Tubing kit
14	7	U8902321	Y adaptor for irrigation tubing
17	5	U8900341	Tubing ID-1/8 OD-1/4
21	1	U8908626	QH-QS-6 valve
22	1	U8902320	Tubing ID-4 mm OD-6 mm blue-trans

- a. This number represents the typical quantity initially included with your scanner package.

## 6.8 Rear Assembly Part 1

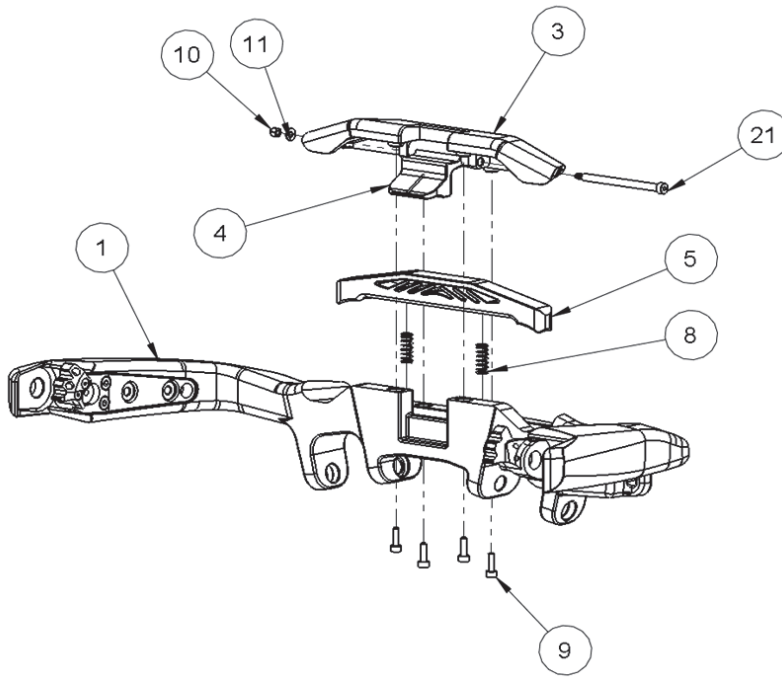

Figure 6-8 Rear assembly exploded view — part 1

Table 8 Rear assembly part 1 — spare parts

Drawing number	Quantity <sup>a</sup>	Part number	Description
1	1	Q8301740	Frame rear
3	1	Q8301741	Cover brake
4	1	Q8301742	Cam brake
5	1	Q8301743	Pad brake
8	2	Q8301744	Spring comp. 0625LG × 0.24 OD × 0.188 ID

**Table 8 Rear assembly part 1 – spare parts (continued)**

Drawing number	Quantity <sup>a</sup>	Part number	Description
9	4	U8908544	Screw m3 × 10 mm stain hex socket cap
10	1	U8779489	Nut M3 stain nylon locking
11	1	Q8301745	Flat washer M3 × 0.5 mm stain
21	1	Q8301746	Screw shoulder sst M3 DIA 4 LG 50.5

- a. This number represents the typical quantity initially included with your scanner package.

## 6.9 Rear Assembly Part 2

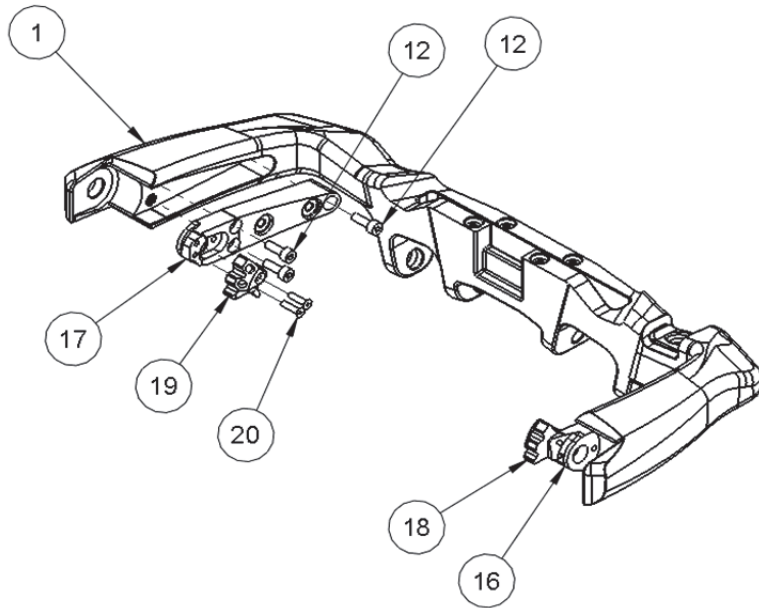
**Figure 6-9 Rear assembly exploded view – part 2**

**Table 9 Rear assembly part 2 – spare parts**

Drawing number	Quantity <sup>a</sup>	Part number	Description
1	1	Q8301740	Frame rear
12	6	Q8301748	Screw M4 × 12 mm stain hex socket cap
16	1	Q8301749	Bracket pivot circumferential left
17	1	Q8301750	Bracket pivot circumferential right
18	1	Q8301751	Pivot circumferential left 0–25 deg
19	1	Q8301752	Pivot circumferential right 0–25 deg
20	2	Q8301753	Screw M3 × 12 mm hex flat stain

- a. This number represents the typical quantity initially included with your scanner package.

## 6.10 Front Assembly Part 1

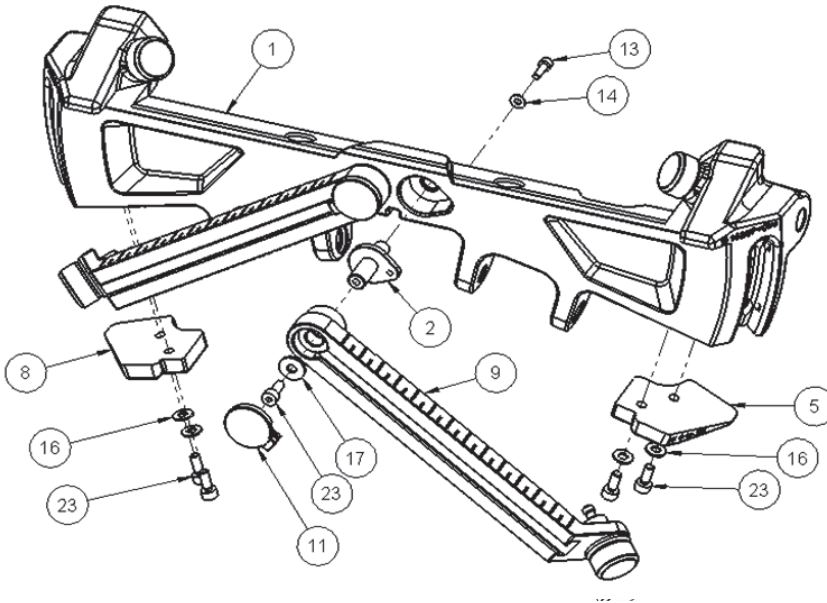
**Figure 6-10 Front assembly exploded view – part 1**



**Table 10 Front assembly part 1 – spare parts**

Drawing number	Quantity <sup>a</sup>	Part number	Description
1	1	Q8301754	Front frame without hardware
2	2	Q8301755	Pin pivot SLA arm
5	1	Q8301756	Stopper low PA arm right
8	1	Q8301757	Stopper low PA arm left
9	2	Q8301758	Arm SLA assembly
11	2	Q8301759	Cap PA arm
13	2	U8908544	Screw M3 × 10 mm stain hex socket cap
14	2	Q8301745	Flat washer M3 × 0.5 mm stain
16	4	U8908516	Washer flat M4 stain
17	2	Q8300207	Flat washer M4 OD 12 mm
23	2	U8770529	Screw M4 × 10 mm stain hex socket cap

- a. This number represents the typical quantity initially included with your scanner package.

## 6.11 Front Assembly Part 2

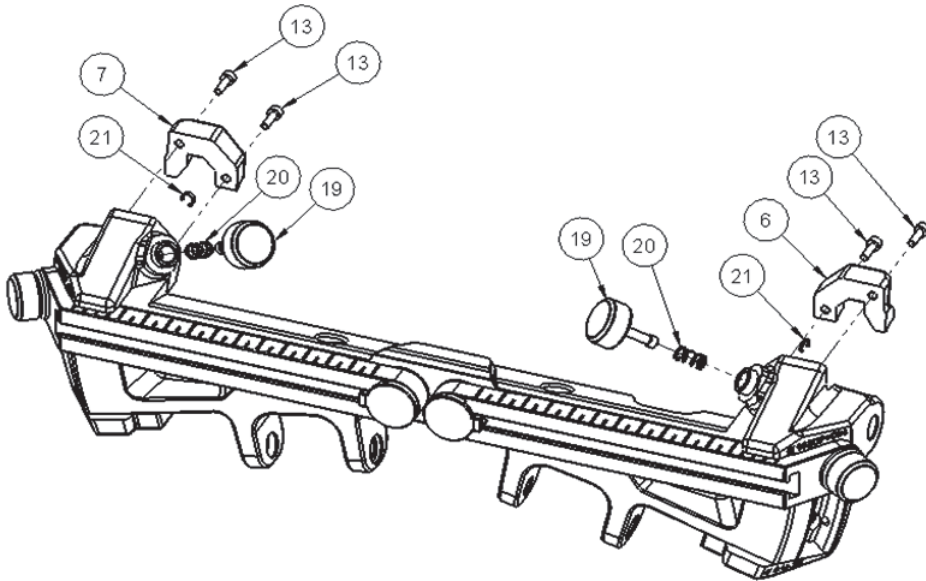

Figure 6-11 Front assembly exploded view – part 2

Table 11 Front assembly part 2 – spare parts

Drawing number	Quantity <sup>a</sup>	Part number	Description
6	1	Q8301760	Frame front circumferential pivot cap_r
7	1	Q8301761	Frame front circumferential pivot cap_l
13	4	U8908544	Screw M3 × 10 mm stain hex socket cap
19	2	Q8301762	Screw thumb circumferential pivot
20	2	Q8301763	Spring comp. OD 0.25 length 0.47
21	2	Q8301764	Ring retaining ext. low clearance 4 mm

- a. This number represents the typical quantity initially included with your scanner package.

## 7. Specifications

This chapter contains the general specifications and connector references for the AxSEAM scanner.

### 7.1 General Specifications

The general specifications for the AxSEAM scanner are provided in Table 12 on page 99. The overall dimensions are illustrated in Figure 7-1 on page 101, wheel and probe holder offset values are illustrated in Figure 7-2 on page 102, and yokes dimensions are illustrated in Figure 7-3 on page 103 and Figure 7-4 on page 103.

**Table 12 General specifications**

Parameter	Value
Dimensions (overall)	Length: 230 mm (9 in.) Width: 377 mm (14.8 in.) Height: 128.3 mm (5 in.)
Weight	8.2 lb (3.7 kg)
Encoder type	Quadrature
Encoder resolution	32 steps/mm $\pm$ 0.15 steps/mm (encoder calibration is recommended for every setup)
Voltage	5 V
Current	100 mA maximum
Frequency	0–1.5 kHz (maximum displacement velocity of 100 mm/s [4 in./s])

**Table 12 General specifications (continued)**

Parameter	Value
Magnetic field strength of wheels	4.67×10 <sup>-9</sup> milligauss (mG) at a distance of 2.1 m (7 ft) away from the wheels. (This below the 5.25 milligauss limit at which restriction would be imposed on air shipment.)
Magnetic strength (one raw magnet on a steel plate)	78.9 lb (35.7 kg)
Minimum longitudinal scanning pipe diameter	Outside scanning: 152 mm (6 in.) OD Inside scanning: 1829 mm (72 in.) ID
Minimum circumferential scanning pipe diameter	Outside scanning: 4 probes: 254 mm (10 in.) OD 2 probes: 114.3 mm (4.4 in.) OD Inside: 1219 mm (48 in.) ID

**Table 13 Operating environment specifications**

Parameter	Value
Operating temperature	-10 °C to 45 °C (14 °F to 113 °F)
Storage temperature	-20 °C to 60 °C (-4 °F to 140 °F)
Relative humidity (RH)	Max. 85 % RH non-condensing
Wet location	Yes
Altitude	Up to 2000 m
Outdoor use	Yes
Pollution degree	4
IP rating	IP57
High temperature operating	Standard MIL-STD 810H Method 501.7 Procedure II, §4.5.3
Low temperature operating	Standard MIL-STD 810H Method 502.7 Procedure II, §4.5.3
High temperature storage	Standard MIL-STD 810H Method 501.7 Procedure I, §4.5.2
Low temperature storage	Standard MIL-STD 810H Method 502.7 Procedure I, §4.5.2

**Table 13 Operating environment specifications (continued)**

Parameter	Value
Thermal shock	Standard MIL-STD 810H Method 503.7 Procedure I-C, Figure 503.7-3
Humidity storage	Standard MIL-STD 810H Method 507.6 Procedure II, Figure 507.6-7

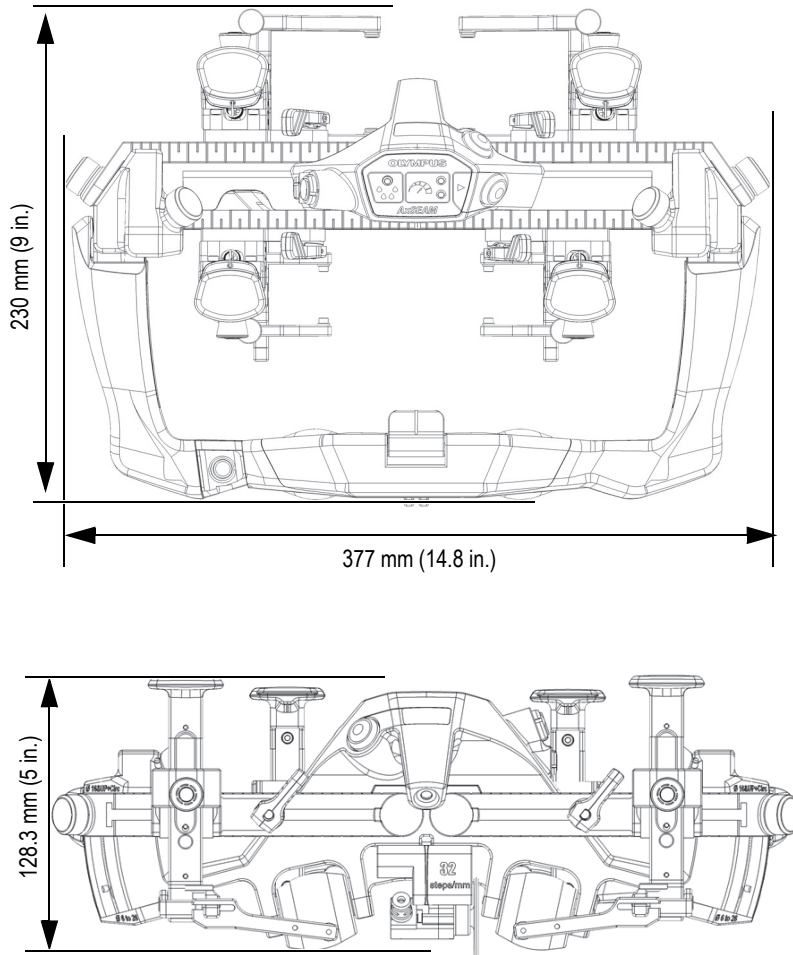
**Figure 7-1 Scanner dimensions**

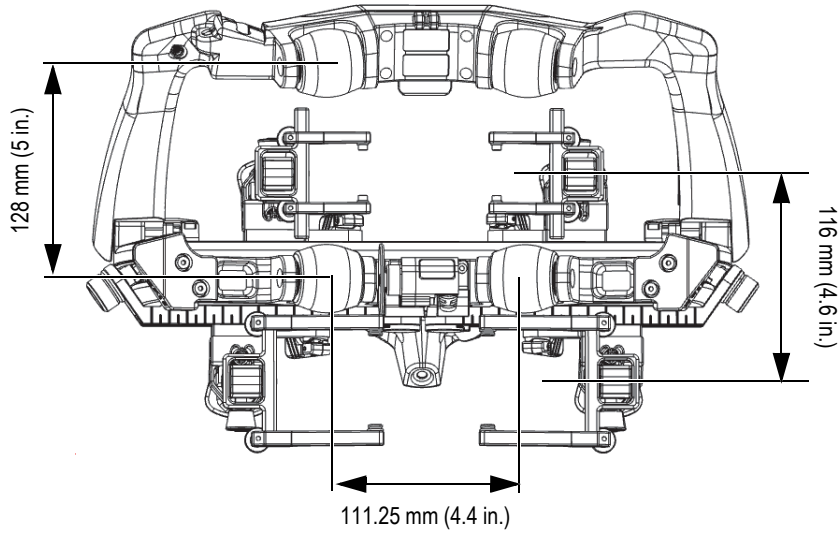

**Figure 7-2 Wheel and probe holder offset values**

**Table 14 Long yoke (PA)**

A Max (mm)	A Min (mm)	B1 far position (mm)	B2 close position (mm)	Button diameter (mm)
55	31.75	54.86	37.85	8

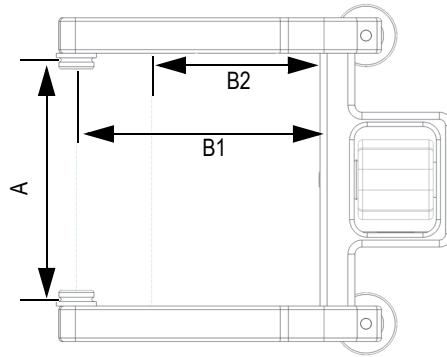

**Figure 7-3** Length and width measurements for the long PA yoke

**Table 15** Short yoke (TOFD)

A Max (mm)	A Min (mm)	B (mm)	Button diameter (mm)
55	31.75	29.72	5

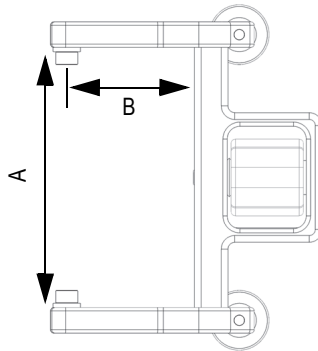

**Figure 7-4** Length and width measurements for the short TOFD yoke

## 7.2 Connectors

The AxSEAM scanner includes the following cables:

- Scanner to OmniScan MX2 or OmniScan X3 instrument cable
- Encoder cable

The scanner to OmniScan cable signal correspondence, function, and pinout is shown in Table 16 on page 104.

**Table 16 Scanner to OmniScan cable connector pin numbers and functions**

OmniScan pin number	Function	Scanner pin number
2	+5 V	1
3	ScanDeck button (DIN 1)	9
5	Scanner detection (DIN 3)	10
7	ScanDeck blue LED	5
8	ScanDeck red LED	6
9	Encoder Phase A	3
10	Encoder Phase B	4
13	ScanDeck green LED	7
16	Ground	8

Figure 7-5 on page 105 contains the pin numbering schematics for the cable connectors.



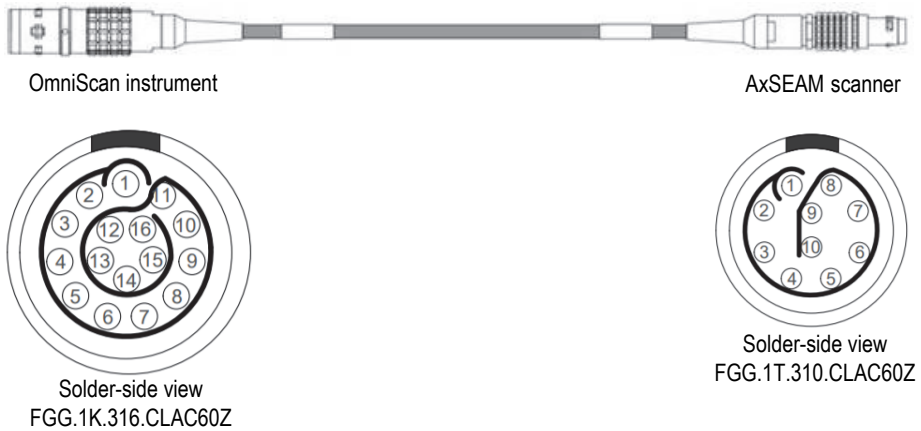

**Figure 7-5 Scanner to OmniScan cable connectors pin numbering schematics**

The encoder cable connector pin numbering schematic and functions are shown in Table 17 on page 105.

Figure 7-6 on page 106 contains the pin numbering schematic for the connector used on the AxSEAM encoder.

**Table 17 Scanner connector pin numbers and functions**

Scanner pin number	Function
1	+5 V
2	Ground
3	PHA
4	PHB
5	N/A

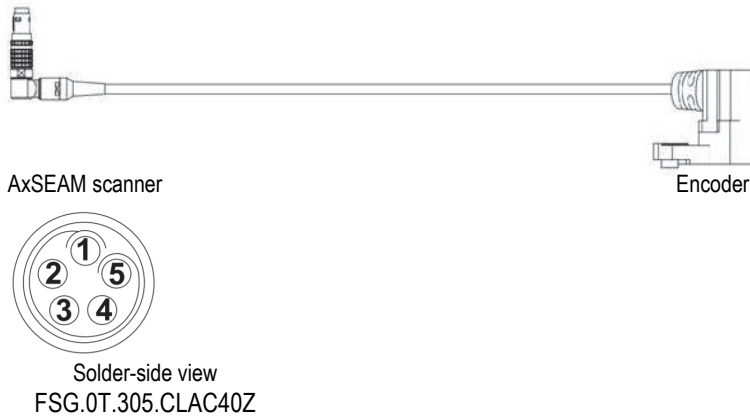

**Figure 7-6 Encoder cable pin numbering schematic**

---

## List of Figures

---

Figure 1-1	Case contents .....	25
Figure 1-2	The AxSEAM scanner .....	27
Figure 1-3	Magnetic wheel .....	29
Figure 1-4	Encoder for measuring scanner position on the surface .....	30
Figure 1-5	Rulers to help position the probe holder .....	31
Figure 1-6	ScanDeck™ module components .....	32
Figure 1-7	Probe holder components .....	34
Figure 1-8	Long yoke with maximum (55 mm) wedge width setting .....	35
Figure 1-9	Long yoke with minimum (31.75 mm) wedge width setting .....	36
Figure 1-10	Short yoke with maximum (55 mm) wedge width setting .....	36
Figure 1-11	Short yoke with minimum (31.75 mm) wedge width setting .....	37
Figure 1-12	Correct alignment of the yoke arms .....	38
Figure 1-13	Incorrect alignment of the yoke arms .....	38
Figure 2-1	Probe holder mounting rail in upward position .....	40
Figure 2-2	Probe holder mounting rails in downward position .....	40
Figure 2-3	Circumferential scanning adjustment knobs .....	41
Figure 2-4	Circumferential frame adjustment in pivoted position for pipes of 406.4 mm (16 in.) OD and lower .....	42
Figure 2-5	Horizontally aligned flat edges .....	43
Figure 2-6	Probe holder alignment with the rail slot .....	44
Figure 2-7	Probe holder inserted into the rail slot .....	44
Figure 2-8	Probe holder secured into place .....	45
Figure 2-9	Position lever unlocked .....	46
Figure 2-10	Sliding the probe holder .....	46
Figure 2-11	Position lever locked .....	47
Figure 2-12	Probe holder assembly parts .....	48
Figure 2-13	Sliding the yoke arm to the tip of the yoke pivoting beam .....	49
Figure 2-14	Aligning the wedge pivot hole with the yoke arm button .....	50
Figure 2-15	Yoke arms removal and shim insertion .....	51
Figure 2-16	Reinstalling the yoke arms .....	51

Figure 2-17	Adjusting the wedge's carbide wear pins .....	52
Figure 2-18	Removing the probe from the wedge .....	53
Figure 2-19	Removal of two screws .....	54
Figure 2-20	Flipping of the SLA bracket .....	55
Figure 2-21	Removal of yoke pivoting beam screw .....	56
Figure 2-22	Sliding out the yoke pivoting beam .....	56
Figure 2-23	Flipping of the yoke pivoting beam .....	57
Figure 2-24	Putting the screw back in .....	58
Figure 2-25	Water tubing assembly .....	59
Figure 2-26	Probe irrigation system .....	60
Figure 2-27	Cable management – zipper .....	61
Figure 2-28	Scanner and OmniScan connected .....	62
Figure 2-29	Removal of the spring from the fixation hole .....	63
Figure 2-30	Removal of the spring .....	64
Figure 3-1	Lanyard attachment point .....	66
Figure 3-2	Sliding the rail to the locking position .....	67
Figure 4-1	Brake lever activated .....	70
Figure 4-2	Brake lever deactivated .....	70
Figure 5-1	Screw removal .....	77
Figure 5-2	Wheel removal – parts .....	78
Figure 5-3	Removal of the rear screw .....	80
Figure 5-4	Removal of the SLA rail .....	81
Figure 5-5	Sliding of the yoke arms .....	82
Figure 6-1	Top assembly exploded view .....	84
Figure 6-2	Magnetic wheel exploded view – Q8301797 .....	86
Figure 6-3	Encoder exploded view .....	87
Figure 6-4	Probe holder exploded view .....	88
Figure 6-5	TOFD yoke arm exploded view .....	90
Figure 6-6	Phased array yoke arm exploded view .....	91
Figure 6-7	Cables management exploded view .....	92
Figure 6-8	Rear assembly exploded view – part 1 .....	94
Figure 6-9	Rear assembly exploded view – part 2 .....	95
Figure 6-10	Front assembly exploded view – part 1 .....	96
Figure 6-11	Front assembly exploded view – part 2 .....	98
Figure 7-1	Scanner dimensions .....	101
Figure 7-2	Wheel and probe holder offset values .....	102
Figure 7-3	Length and width measurements for the long PA yoke .....	103
Figure 7-4	Length and width measurements for the short TOFD yoke .....	103
Figure 7-5	Scanner to OmniScan cable connectors pin numbering schematics .....	105
Figure 7-6	Encoder cable pin numbering schematic .....	106

---

## List of Tables

---

Table 1	Top assembly spare parts .....	84
Table 2	Magnetic wheel spare parts .....	86
Table 3	Encoder spare parts .....	87
Table 4	Probe holder spare parts .....	89
Table 5	TOFD yoke arm spare parts .....	90
Table 6	Phased array yoke arm spare parts .....	92
Table 7	Cable management spare parts .....	93
Table 8	Rear assembly part 1 — spare parts .....	94
Table 9	Rear assembly part 2 — spare parts .....	96
Table 10	Front assembly part 1 — spare parts .....	97
Table 11	Front assembly part 2 — spare parts .....	98
Table 12	General specifications .....	99
Table 13	Operating environment specifications .....	100
Table 14	Long yoke (PA) .....	102
Table 15	Short yoke (TOFD) .....	103
Table 16	Scanner to OmniScan cable connector pin numbers and functions .....	104
Table 17	Scanner connector pin numbers and functions .....	105

