



# HydroFORM

## Manual Corrosion Scanner

### User's Manual

10-036042-01EN — Rev. 3  
October 2023



This instruction manual contains essential information on how to use this Evident product safely and effectively. Before using this product, thoroughly review this instruction manual. Use the product as instructed. Keep this instruction manual in a safe, accessible location.

EVIDENT CANADA, INC., 3415, rue Pierre-Ardouin, Quebec (Quebec) G1P 0B3 Canada

Copyright © 2023 by Evident. All rights reserved. No part of this publication may be reproduced, translated, or distributed without the express written permission of Evident.

This document was prepared with particular attention to usage to ensure the accuracy of the information contained therein, and corresponds to the version of the product manufactured prior to the date appearing on the title page. There could, however, be some differences between the manual and the product if the product was modified thereafter.

The information contained in this document is subject to change without notice.

Part number: 10-036042-01EN

Rev. 3

October 2023

Printed in Canada

All brands are trademarks or registered trademarks of their respective owners and third party entities.

---

---

# Table of Contents

---

<b>List of Abbreviations .....</b>	<b>7</b>
<b>Important Information – Please Read Before Use .....</b>	<b>9</b>
Intended Use .....	9
Instruction Manual .....	9
Device Compatibility .....	10
Repair and Modification .....	10
Safety Symbols .....	10
Safety Signal Words .....	11
Note Signal Words .....	12
Safety .....	12
Warnings .....	13
Equipment Disposal .....	13
CE (European Conformity) .....	14
UKCA (United Kingdom) .....	14
WEEE Directive .....	14
China RoHS .....	14
Korea Communications Commission (KCC) .....	16
KC (South Korea Community) .....	16
FCC (USA) Compliance .....	16
ICES-001 (Canada) Compliance .....	17
Packing and Return Shipping .....	18
Warranty Information .....	18
Technical Support .....	19
<b>Introduction .....</b>	<b>21</b>
ScanDeck Module .....	21
HydroFORM Configurations .....	21

<b>1. HydroFORM Scanner Overview .....</b>	<b>23</b>
1.1 Case Contents .....	23
1.2 Scanner Components .....	25
1.3 Carriage .....	26
1.3.1 Wheels .....	28
1.3.2 Probe Holder Lock-Release Lever .....	28
1.3.3 Brake .....	28
1.4 ScanDeck Module .....	29
1.4.1 ScanDeck Control Pad .....	30
1.4.2 Status LED .....	31
1.4.3 Coupling Check LED .....	31
1.4.4 ScanDeck Button .....	32
1.4.5 Encoder Arrow LEDs .....	32
1.5 Encoders .....	33
1.5.1 Scan Axis Encoder .....	33
1.5.2 Index Axis Encoder (Optional) .....	34
1.5.2.1 Index Encoder Positions .....	34
1.5.2.2 Encoder Wheel Friction Ring .....	34
1.6 Phased Array Probe .....	35
1.7 Probe Holder Assembly .....	36
1.7.1 Probe Holder .....	37
1.7.2 Delay Line Plate .....	37
1.7.3 Foam Gasket .....	37
1.7.4 Gasket Protector .....	37
1.8 Umbilical .....	37
1.8.1 Umbilical Hook .....	38
1.8.2 Irrigation Parts .....	39
1.8.3 Protective Sleeve .....	39
<b>2. Scanner Setup and Configuration .....</b>	<b>41</b>
2.1 Magnetic Wheel Safety .....	41
2.2 Clicker Scan Setup on the ScanDeck Module .....	42
2.2.1 OmniScan X3 Setup .....	42
2.2.2 OmniScan MX2 and SX Setup .....	42
2.3 Raster Scan Setup on the ScanDeck Module with Index Encoder .....	43
2.3.1 OmniScan X3 Setup .....	43
2.3.2 OmniScan MX2 and SX Setup .....	43
2.4 Raster Scanning Using an Auxiliary Scanner .....	43
2.4.1 Modifying the Manual HydroFORM Version for Auxiliary Scanners ...	47
2.4.2 Removing and Installing the Index Encoder .....	48
2.4.3 Removing and Installing the ScanDeck Module .....	50



---

2.4.4	Changing the Wheels .....	51
<b>3.</b>	<b>Preparation for Inspection .....</b>	<b>53</b>
3.1	Changing the Delay Line Height .....	53
3.2	Adjusting the Index Encoder Wheel Resistance .....	54
3.3	Drawing Lines or Marks on the Surface .....	56
3.4	Installing the Foam Gasket Protector .....	56
<b>4.</b>	<b>Operating the HydroFORM Scanner .....</b>	<b>59</b>
4.1	Hand Positions on the Scanner .....	59
4.2	Probe Holder Height Adjustment and Water Chamber Filling .....	61
4.3	Validating the Coupling Status Using the ScanDeck Module .....	64
4.4	Operating the HydroFORM Scanner in Clicker Mode .....	64
4.5	Operating the HydroFORM Scanner in Raster Mode .....	65
4.5.1	Performing a Raster Scan in Guided Mode .....	65
4.5.2	Stowing and Releasing the Index Encoder .....	66
4.5.3	Performing a Raster Scan in Freehand Mode .....	68
<b>5.</b>	<b>Maintenance .....</b>	<b>71</b>
5.1	Cleaning the Unit .....	71
5.2	Replacing the Foam Gasket on the Delay Line Plate .....	72
5.3	Cleaning the Delay Line Vent Holes .....	75
5.4	Replacing the Probe .....	77
5.5	Changing the Brake Pad .....	78
5.6	Removing the Brake Shaft and Brake Lever .....	80
5.7	Changing the Probe Holder Lock-Release Pad .....	82
5.8	Index Encoder Maintenance .....	83
5.8.1	Changing the Index Encoder Assembly .....	83
5.8.2	Changing the Index Encoder Wheel .....	85
5.8.3	Changing the Friction Ring .....	86
5.9	Cleaning the Magnetic Wheels .....	87
<b>6.</b>	<b>Specifications .....</b>	<b>89</b>
6.1	General Specifications .....	89
6.2	Cable Pinout and Connector Reference .....	91
6.3	Digital Signal Assignment .....	91
6.4	Dimensions and Clearances .....	91
<b>7.</b>	<b>Spare Parts and Accessories .....</b>	<b>95</b>
7.1	HydroFORM Scanner Spare Parts .....	95
7.2	Spare Part Kits .....	104

---

7.3	HydroFORM Holders .....	109
7.3.1	Fork Kit .....	109
7.3.2	ChainSCANNER Pivoting Probe Holder .....	110
7.3.3	Heavy Duty Probe Holder .....	111
7.3.4	MapSCANNER Carriage .....	112
7.3.5	MapROVER/SteerROVER Probe Holder .....	113
<b>Appendix A: ScanDeck Commands .....</b>		<b>117</b>
<b>List of Figures .....</b>		<b>119</b>
<b>List of Tables .....</b>		<b>123</b>

---

## List of Abbreviations

---

CLK	clock
EFUP	environment-friendly use period
IP	International (ingress) Protection
RH	relative humidity



---

## Important Information — Please Read Before Use

---

### Intended Use

The HydroFORM scanner is designed to perform nondestructive inspections on industrial and commercial materials.



#### **WARNING**

Do not use the HydroFORM scanner for any purpose other than its intended use. It must never be used to inspect or examine human or animal body parts.

---

### Instruction Manual

This instruction manual contains essential information on how to use this Evident product safely and effectively. Before using this product, thoroughly review this instruction manual. Use the product as instructed.

---

#### **IMPORTANT**

Some of the details of components and/or software images in this manual may differ from your device's components or software display. However, the principles remain the same.

---

## Device Compatibility

Only use this device with the approved ancillary equipment provided by Evident. Equipment provided by Evident and approved for use with this device is described later in this manual.

---



### CAUTION

Always use equipment and accessories that meet Evident specifications. Using incompatible equipment could cause equipment malfunction and/or damage, or human injury.

---

## Repair and Modification

This device does not contain any user-serviceable parts. Opening the device might void the warranty.

---



### CAUTION

In order to prevent human injury and/or equipment damage, do not disassemble, modify, or attempt to repair the device.

---

## Safety Symbols

The following safety symbols might appear on the device and in the instruction manual:



General warning symbol

This symbol is used to alert the user to potential hazards. All safety messages that follow this symbol shall be obeyed to avoid possible harm or material damage.

---



#### High voltage warning symbol

This symbol is used to alert the user to potential electric shock hazards greater than 1000 volts. All safety messages that follow this symbol shall be obeyed to avoid possible harm.



#### Finger crushing warning symbol

This symbol is used to alert the user to potential hazards to fingers from crushing by magnetic wheels. All safety messages that follow this symbol shall be obeyed to avoid possible harm.



#### Magnetic field warning symbol

This symbol is used to alert the user to potentially strong magnetic fields. All safety messages that follow this symbol shall be obeyed to avoid possible harm.

## Safety Signal Words

The following safety signal words might appear in the documentation of the device:



### **DANGER**

The DANGER signal word indicates an imminently hazardous situation. It calls attention to a procedure, practice, or the like that if not correctly performed or adhered to will result in death or serious personal injury. Do not proceed beyond a DANGER signal word until the indicated conditions are fully understood and met.



### **WARNING**

The WARNING signal word indicates a potentially hazardous situation. It calls attention to a procedure, practice, or the like that if not correctly performed or adhered to could result in death or serious personal injury. Do not proceed beyond a WARNING signal word until the indicated conditions are fully understood and met.



## CAUTION

The CAUTION signal word indicates a potentially hazardous situation. It calls attention to a procedure, practice, or the like that if not correctly performed or adhered to may result in minor or moderate personal injury, material damage, particularly to the product, destruction of part or all of the product, or loss of data. Do not proceed beyond a CAUTION signal word until the indicated conditions are fully understood and met.

## Note Signal Words

The following note signal words could appear in the documentation of the device:

### IMPORTANT

The IMPORTANT signal word calls attention to a note that provides information that is important or essential to the completion of a task.

### NOTE

The NOTE signal word calls attention to an operating procedure, practice, or the like, that requires special attention. A note also denotes related parenthetical information that is useful, but not imperative.

### TIP

The TIP signal word calls attention to a type of note that helps you apply the techniques and procedures described in the manual to your specific needs, or that provides hints on how to effectively use the capabilities of the product.

## Safety

Before turning on the device, verify that the correct safety precautions have been taken (see “Warnings” on page 13). In addition, note the external markings on the device, which are described under “Safety Symbols.”



## Warnings



### WARNING

#### General Warnings

- Carefully read the instructions contained in this instruction manual prior to turning on the device.
- Keep this instruction manual in a safe place for further reference.
- Follow the installation and operation procedures.
- It is imperative to respect the safety warnings on the device and in this instruction manual.
- If the equipment is used in a manner not specified by the manufacturer, the protection provided by the equipment could be impaired.
- Do not install substitute parts or perform any unauthorized modification to the device.
- Service instructions, when applicable, are for trained service personnel. To avoid the risk of electric shock, do not perform any work on the device unless qualified to do so. For any problem or question regarding this device, contact Evident or an authorized Evident representative.
- Do not touch the connectors directly by hand. Otherwise, a malfunction or electric shock may result.
- Do not allow metallic or foreign objects to enter the device through connectors or any other openings. Otherwise, a malfunction or electric shock may result.
- Make sure no components (screws, straps, etc.) have come loose or are lost in critical equipment being inspected. Thoroughly check your inspection area before and after an inspection to prevent foreign-object debris (FOD) that could potentially cause equipment damage, injuries, or loss of life.

## Equipment Disposal

Before disposing of the device, check your local laws, rules, and regulations, and follow them accordingly.

## CE (European Conformity)



This device complies with the requirements of directive 2014/30/EU concerning electromagnetic compatibility, directive 2014/35/EU concerning low voltage, and directive 2015/863 which amends 2011/65/EU concerning restriction of hazardous substances (RoHS). The CE marking is a declaration that this product conforms to all the applicable directives of the European Community.

## UKCA (United Kingdom)



This device complies with the requirements of the Electromagnetic Compatibility Regulations 2016, the Electrical Equipment (Safety) Regulations 2016, and the Restriction of the Use of Certain Hazardous Substances in Electrical and Electronic Equipment Regulations 2012. The UKCA marking indicates compliance with the above regulations.

## WEEE Directive



In accordance with European Directive 2012/19/EU on Waste Electrical and Electronic Equipment (WEEE), this symbol indicates that the product must not be disposed of as unsorted municipal waste, but should be collected separately. Refer to your local Evident distributor for return and/or collection systems available in your country.

## China RoHS

*China RoHS* is the term used by industry generally to describe legislation implemented by the Ministry of Information Industry (MII) in the People's Republic of China for the control of pollution by electronic information products (EIP).



The China RoHS mark indicates the product's Environment-Friendly Use Period (EFUP). The EFUP is defined as the number of years for which listed controlled substances will not leak or chemically deteriorate while in the product. The EFUP for the HydroFORM has been determined to be 15 years.

**Note:** The Environment-Friendly Use Period (EFUP) is not meant to be interpreted as the period assuring functionality and product performance.



电器电子产品有害物质限制使用标志

本标志是根据“电器电子产品有害物质限制使用管理办法”以及“电子电气产品有害物质限制使用标识要求”的规定，适用于在中国销售的电器电子产品上的电器电子产品有害物质使用限制标志。

(注意) 电器电子产品有害物质限制使用标志内的数字为在正常的使用条件下有害物质等不泄漏的期限，不是保证产品功能性能的期间。

产品中有害物质的名称及含量

部件名称		有害物质					
		铅及其化合物 (Pb)	汞及其化合物 (Hg)	镉及其化合物 (Cd)	六价铬及其化合物 (Cr(VI))	多溴联苯 (PBB)	多溴二苯醚 (PBDE)
主体	机构部件	×	○	○	○	○	○
	光学部件	×	○	○	○	○	○
	电气部件	×	○	○	○	○	○
附件		×	○	○	○	○	○

本表格依据 SJ/T 11364 的规定编制。

○：表示该有害物质在该部件所有均质材料中的含量均在 GB/T26572 规定的限量要求以下。

×：表示该有害物质至少在该部件的某一均质材料中的含量超出 GB/T26572 规定的限量要求。

## Korea Communications Commission (KCC)



Seller and user shall be noticed that this equipment is suitable for electromagnetic equipment for office work (class A) and it can be used outside the home. This device complies with the EMC requirements of Korea.

The MSIP code for the device is the following: R-R-OYN-HYDROFORM.

이 기기는 업무용 환경에서 사용할 목적으로 적합성평가를 받은 기기로서 가정용 환경에서 사용하는 경우 전파간섭의 우려가 있습니다.

## KC (South Korea Community)

This device complies with the requirements of KS C 9610-6-2 and KS C 9610-6-4 concerning electromagnetic compatibility. The KC marking indicates compliance with the above standards.

## FCC (USA) Compliance

---

<b>NOTE</b>
-------------

This product has been tested and found to comply with the limits for a Class A digital device, pursuant to Part 15 of the FCC Rules. These limits are designed to provide reasonable protection against harmful interference when the product is operated in a commercial environment. This product generates, uses, and can radiate radio frequency energy, and if not installed and used in accordance with the instruction manual, might cause harmful interference to radio communications. Operation of this product in a residential area is likely to cause harmful interference, in which case you will be required to correct the interference at your own expense.

---

**IMPORTANT**

Changes or modifications not expressly approved by the party responsible for compliance could void the user's authority to operate the product.

---

### **FCC Supplier's Declaration of Conformity**

Hereby declares that the product,

Product name: HydroFORM

Model: HydroFORM

Conforms to the following specifications:

FCC Part 15, Subpart B, Section 15.107 and Section 15.109.

Supplementary information:

This device complies with Part 15 of the FCC Rules. Operation is subject to the following two conditions:

- (1) This device may not cause harmful interference.
- (2) This device must accept any interference received, including interference that may cause undesired operation.

Responsible party name:

EVIDENT SCIENTIFIC, INC.

Address:

48 Woerd Avenue, Waltham, MA 02453, USA

Phone number:

+1 781-419-3900

### **ICES-001 (Canada) Compliance**

This Class A digital apparatus complies with Canadian ICES-001.

Cet appareil numérique de la classe A est conforme à la norme NMB-001 du Canada.

## Packing and Return Shipping

If the device is not returned in its transport case, it could be damaged during shipping. Evident reserves the right to void the warranty on devices damaged while in transit if they are shipped without their transport case. Prior to returning any units, contact Customer Service to obtain the required RMA number(s) and any important shipping information.

Follow the steps below to return your device:

1. Pack the device back into the transport case that it came in using the original packing materials.
2. Include the RMA in the case, and reference the RMA number in your shipping documents.
3. Close the transport case and Secure the case with plastic zip ties.
4. Pack the transport case within another box.

## Warranty Information

Evident guarantees your Evident product to be free from defects in materials and workmanship for a specific period, and in accordance with conditions specified in the *Evident Terms and Conditions* available at <https://evidentscientific.com/evident-terms/>.

The Evident warranty only covers equipment that has been used in a proper manner, as described in this instruction manual, and that has not been subjected to excessive abuse, attempted unauthorized repair, or modification.

Inspect materials thoroughly on receipt for evidence of external or internal damage that might have occurred during shipment. Immediately notify the carrier making the delivery of any damage, because the carrier is normally liable for damage during shipment. Retain packing materials, waybills, and other shipping documentation needed in order to file a damage claim. After notifying the carrier, contact Evident for assistance with the damage claim and equipment replacement, if necessary.

This instruction manual explains the proper operation of your Evident product. The information contained herein is intended solely as a teaching aid, and shall not be used in any particular application without independent testing and/or verification by the operator or the supervisor. Such independent verification of procedures becomes increasingly important as the criticality of the application increases. For this reason,

Evident makes no warranty, expressed or implied, that the techniques, examples, or procedures described herein are consistent with industry standards, nor that they meet the requirements of any particular application.

Evident reserves the right to modify any product without incurring the responsibility for modifying previously manufactured products.

## **Technical Support**

Evident is firmly committed to providing the highest level of customer service and product support. If you experience any difficulties when using our product, or if it fails to operate as described in the documentation, first consult the user's manual, and then, if you are still in need of assistance, contact our After-Sales Service. To locate the nearest service center, visit the Service Centers page at <https://www.evidentscientific.com/service-and-support/service-centers/>.





---

## Introduction

---

This manual contains instructions on assembling, installing, and operating the HydroFORM scanner.

The HydroFORM scanner is designed for manual corrosion inspection on flat surfaces, tank walls, pressure vessels, and pipes with an outside diameter of four inches or larger.

It enables detection of wall-thickness reductions caused by corrosion, abrasion, and erosion. It also enables detection of midwall damage, such as hydrogen-induced blistering or manufacturing-induced laminations, and the differentiation of these anomalies from loss of wall thickness.

## ScanDeck Module

The manual version of the HydroFORM scanner features a ScanDeck module with a remote action button and LEDs providing visual feedback directly on the scanner when connected to OmniScan X3 or later instruments. This enables the operator to perform scans without having to interact with the OmniScan instrument (see Figure 1-8 on page 30).

## HydroFORM Configurations

In the manual configuration, the HydroFORM scanner can perform single axis encoded scans. With the optional index encoder, the scanner can perform dual axis fully encoded scans.

The HydroFORM scanner can also be mounted on compatible Evident scanners for higher accuracy and/or productivity.

**Table 1 Compatible scanners**

<b>Semiautomated</b>	<b>Motorized</b>
ChainSCANNER	MapROVER
MapSCANNER	SteerROVER

---

# 1. HydroFORM Scanner Overview

---

This chapter provides an overview of the HydroFORM scanner.



Figure 1-1 HydroFORM Scanner with ScanDeck module and index encoder

## 1.1 Case Contents

The contents of a HydroFORM case are shown in Figure 1-2 on page 24.



**Figure 1-2 HydroFORM case contents**

The case is configured to hold the following parts:

- HydroFORM scanner unit
- Umbilical, includes encoder cable, and irrigation tube in a protective sleeve
- 14 mm and 38 mm delay line plates
- Spare parts
- Documentation



**WARNING**



The scanner has magnetic wheels that must be carefully handled to prevent the risk of injury and equipment damage from magnetic fields and inadvertent attractive forces. Before unpacking and handling the case contents, observe the magnetic wheel safety precautions outlined in “Magnetic Wheel Safety” on page 41.

---

## 1.2 Scanner Components

The HydroFORM scanner's components are shown in Figure 1-3 on page 25.

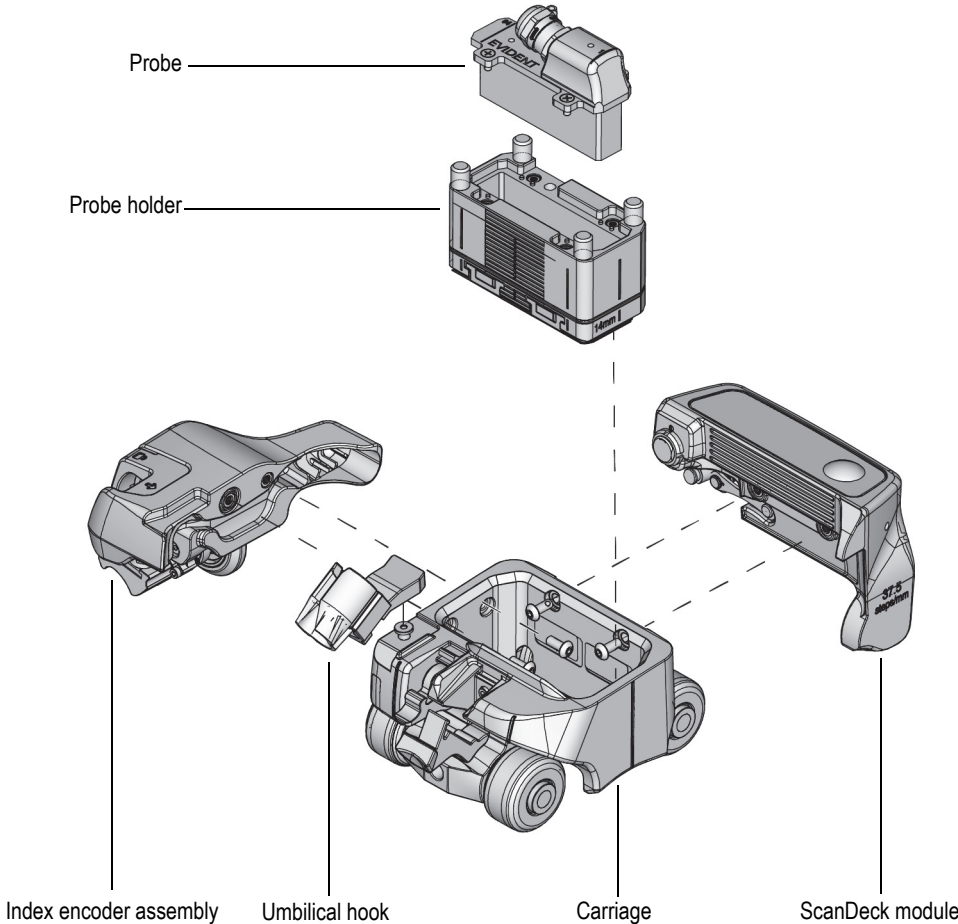
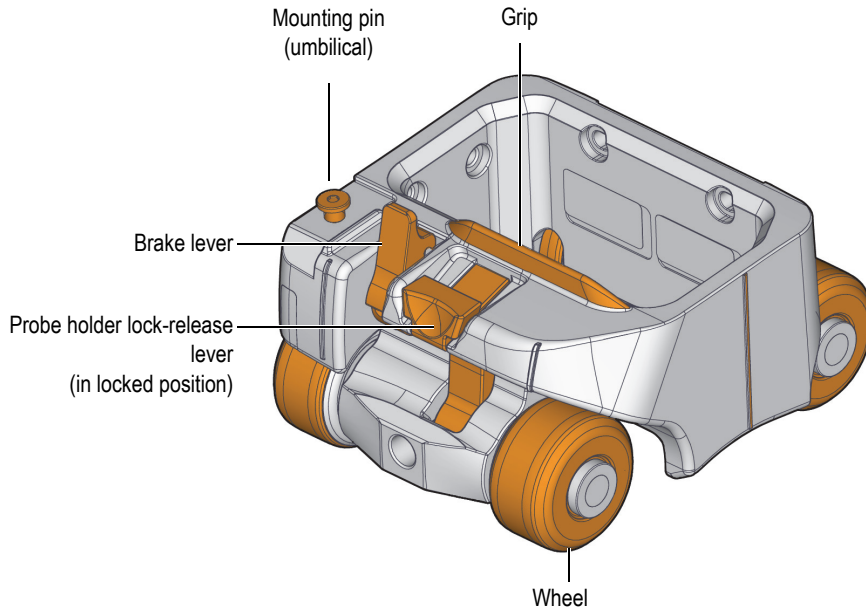

Figure 1-3 HydroFORM scanner components

## 1.3 Carriage

The carriage features wheels, a brake system, a probe holder lock-release lever, and a mounting pin for the umbilical. The grip surface is textured with ridges (see Figure 1-4 on page 26).



**Figure 1-4 Carriage**

The probe array's first and last (sixty-fourth) element positions as well as the probe center axis are indicated by vertical ridges on the carriage body (see Figure 1-5 on page 27 and Figure 1-6 on page 27).

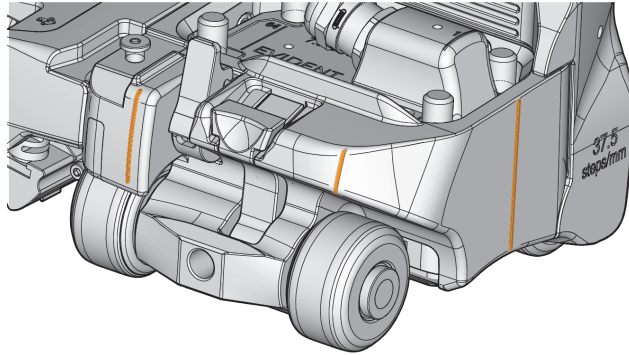

Figure 1-5 Carriage ridges

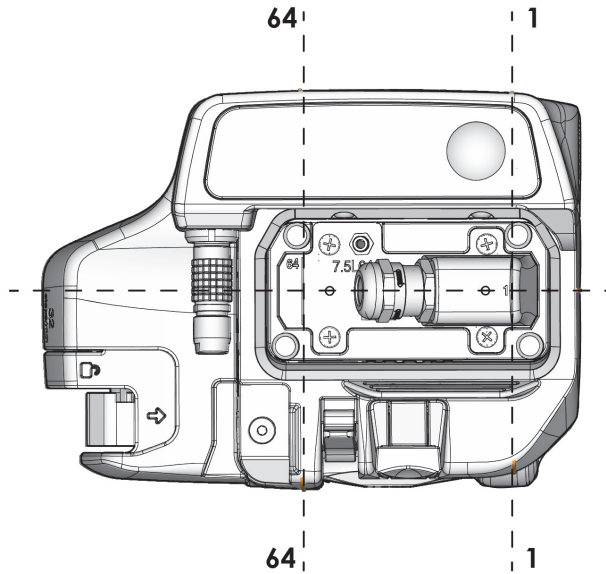

Figure 1-6 Probe array first and sixty-fourth elements

### **1.3.1 Wheels**

Depending on the configuration, the HydroFORM scanner will either be equipped with magnetic or nonmagnetic wheels.

The magnetic wheels maintain the scanner against ferromagnetic surfaces. They are designed to allow sideways movement when manually indexing the scanner (see Figure 1-4 on page 26). For more details, see “Magnetic Wheel Safety” on page 41.

Nonmagnetic wheels are used when another scanner provides sufficient force to maintain the HydroFORM scanner against the surface.

### **1.3.2 Probe Holder Lock-Release Lever**

This lever is part of the latching mechanism that locks the probe holder in place inside the HydroFORM carriage (see Figure 1-4 on page 26). You can release the lever to remove the probe holder or adjust its height. See “Probe Holder Height Adjustment and Water Chamber Filling” on page 61.

For instructions on replacing the probe holder lock-release pad, see “Changing the Probe Holder Lock-Release Pad” on page 82.

### **1.3.3 Brake**

The brake is used to immobilize the scanner on the inspection surface. It prevents wheel rotation on one axle. Fully depress and latch the brake lever to apply the brake (see Figure 1-7 on page 29).

For instructions on how to change the brake pad, see “Changing the Brake Pad” on page 78.



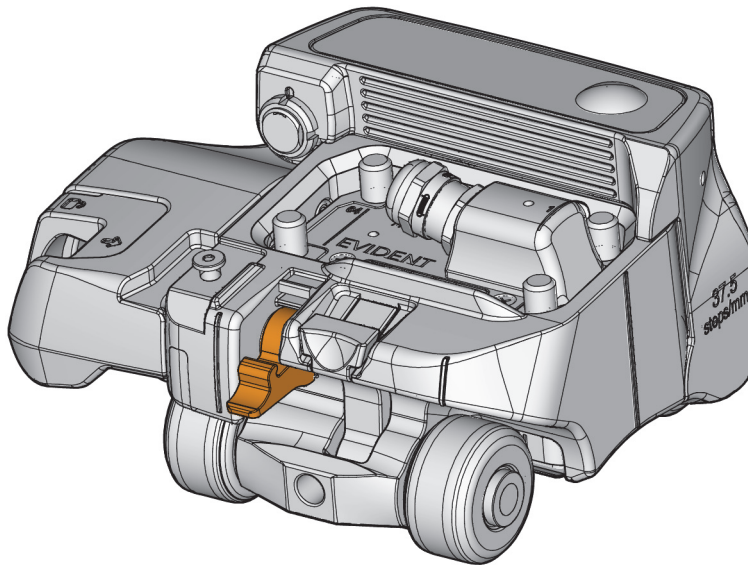

Figure 1-7 Brake lever (engaged)

## 1.4 ScanDeck Module

The ScanDeck module contains a control pad, a scan axis encoder, and two connectors (see Figure 1-8 on page 30).



### CAUTION

To prevent contamination and damage, ensure that the designated plug is in the index encoder connector whenever it is not in use.

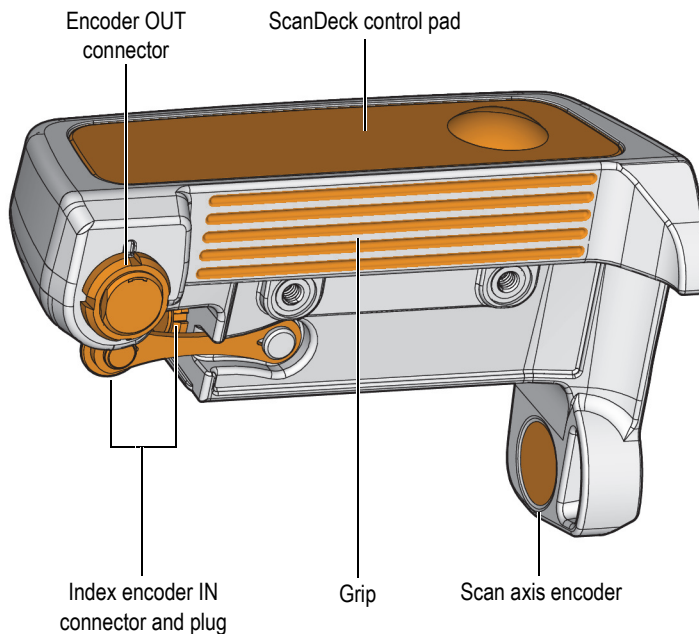

**Figure 1-8 ScanDeck module**

---

**NOTE**

The ScanDeck module is fully compatible with OmniScan X3 or later instruments. Functionalities associated with the status light and Guided mode are not supported on OmniScan MX, MX2, and SX instruments. To learn how to set up the coupling check feature on those units, please refer to their respective *User's Manuals*.

---

### 1.4.1 ScanDeck Control Pad

The ScanDeck control pad provides feedback and basic scan control to the operator (see Figure 1-9 on page 31).

For additional information, see “ScanDeck Commands” on page 117.

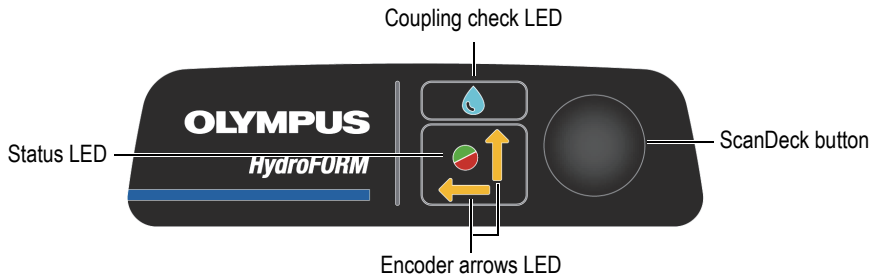

**Figure 1-9 ScanDeck control pad**

## 1.4.2 Status LED

The status LED guides you during operation of the HydroFORM scanner (see Figure 1-9 on page 31). For details, see Table 2 on page 31.

**Table 2 ScanDeck status LED behavior**

LED illumination	Scanner state
Green, continuous	Ready to scan
Short blink	“Clear all” on OmniScan after long press
Red, continuous	Not ready to scan
Red, flashing	Scan speed exceeded
Off	Index distance not reached

## 1.4.3 Coupling Check LED

The coupling check LED indicates the couplant flow condition (see Figure 1-9 on page 31). For details, see Table 3 on page 32.

**Table 3 Couplant check LED behavior**

LED illumination	Scanner state
Blue, continuous	Good coupling
Blue, flashing	Incomplete coupling

## 1.4.4 ScanDeck Button

The ScanDeck button enables basic OmniScan operations from the scanner (see Figure 1-9 on page 31). For details, see Table 4 on page 32.

**Table 4 ScanDeck button**

Action	Remote OmniScan operations
Short press, 0.25 sec	Change between Scan and Index status
Long press, 2 sec	Clear all
Extra-long press, 8 sec	Toggle between Clicker and Raster scan mode
Double press	In Raster scan mode, toggle between Guided and Freehand mode In Clicker mode, index backwards

## 1.4.5 Encoder Arrow LEDs

The encoder arrow LEDs indicate which encoder is active. These LEDs are inactive when the scanner is in Clicker mode and active when in Raster mode (see Figure 1-9 on page 31).

For more ScanDeck operation details, see “Operating the HydroFORM Scanner” on page 59.

## 1.5 Encoders

The HydroFORM scanner can be equipped with two encoders to record the scanner's position in the scan axis (X) and index axis (Y) (see Figure 1-10 on page 33).

Both encoders' signals are routed through the ScanDeck module and then sent to the instrument.

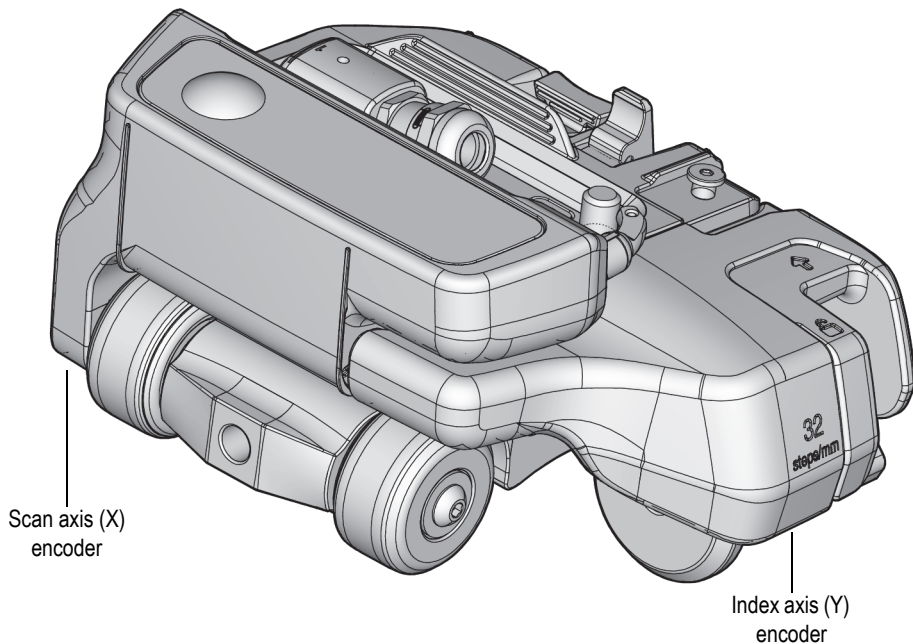

**Figure 1-10 Encoder locations**

### 1.5.1 Scan Axis Encoder

The scan (X) encoder chip is located in the ScanDeck module, and it reads the rotation of the front wheel shaft.

## 1.5.2 Index Axis Encoder (Optional)

The index encoder is housed in a separate unit mounted on the side of the scanner body.

### 1.5.2.1 Index Encoder Positions

The index encoder wheel can be released or stowed inside the encoder housing. See Figure 1-11 on page 34.

For more information, see “Stowing and Releasing the Index Encoder” on page 66.

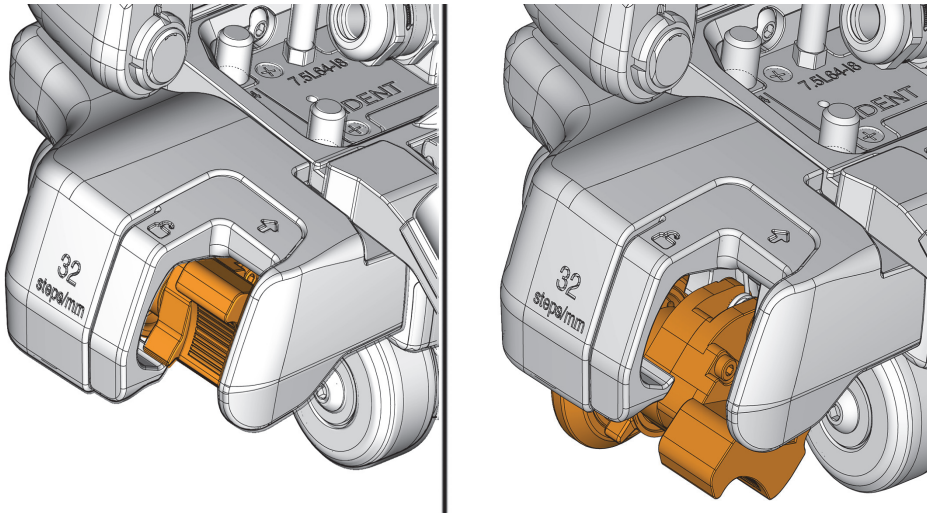

**Figure 1-11 Encoder stowed and released**

### 1.5.2.2 Encoder Wheel Friction Ring

The index encoder wheel's turning resistance may need to be adjusted before scanning in order to optimize the drift and slip resistance of the wheel (see Figure 1-12 on page 35). For more details, see “Adjusting the Index Encoder Wheel Resistance” on page 54.

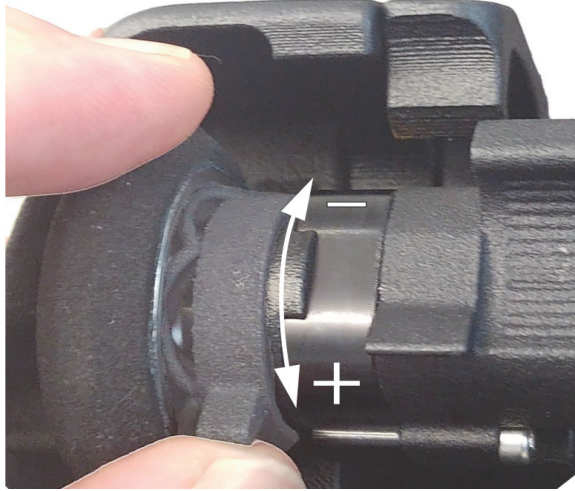

**Figure 1-12 Encoder friction ring**

## 1.6 Phased Array Probe

The scanner comes supplied with a 7.5 MHz, 64 element phased array probe (see Figure 1-13 on page 35).

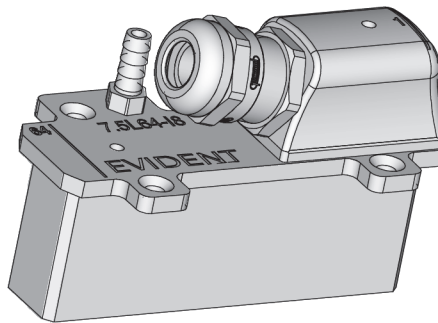
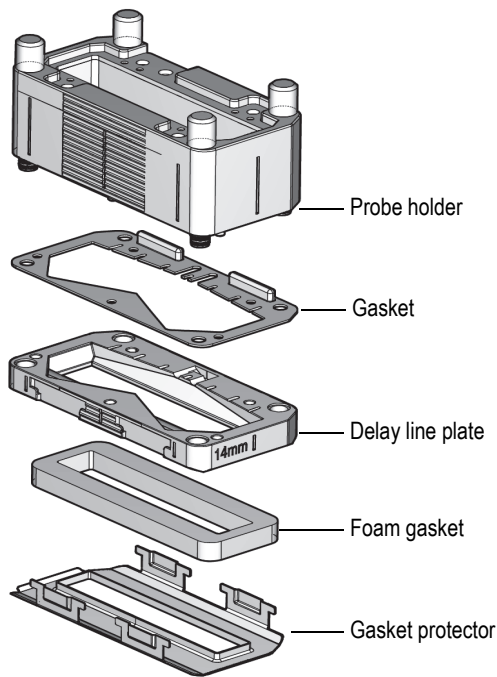

**Figure 1-13 Phased array probe**

## 1.7 Probe Holder Assembly

The probe holder assembly includes the following components (see Figure 1-14 on page 36):

- Probe holder
- Gasket
- Delay line plate
- Foam gasket
- Gasket protector



**Figure 1-14 Probe holder**



### **1.7.1 Probe Holder**

The probe holder body features a couplant inlet port and internal passages to route the couplant to the delay line and evacuate air bubbles. It also features captive thumb screws to mount the delay line plate.

### **1.7.2 Delay Line Plate**

Delay line plates with heights of 14 mm and 38 mm are included for a thickness range from 0 mm up to 150 mm in steel.

### **1.7.3 Foam Gasket**

The foam gasket conforms to the inspection surface and reduces water consumption.

The foam is a consumable item, and wears with use. The life expectancy of the foam gasket depends upon the inspected surface condition. The rougher the surface, the faster the foam gasket will wear out (see “Replacing the Foam Gasket on the Delay Line Plate” on page 72).

### **1.7.4 Gasket Protector**

Use the gasket protector in situations where the foam gasket wears too quickly.

## **1.8 Umbilical**

The umbilical protects the encoder cable, irrigation tube, and probe cable in a protective sleeve. The umbilical hook has integrated cable and tube management cavities for reliable routing to the different carriage connections (see Figure 1-15 on page 38).

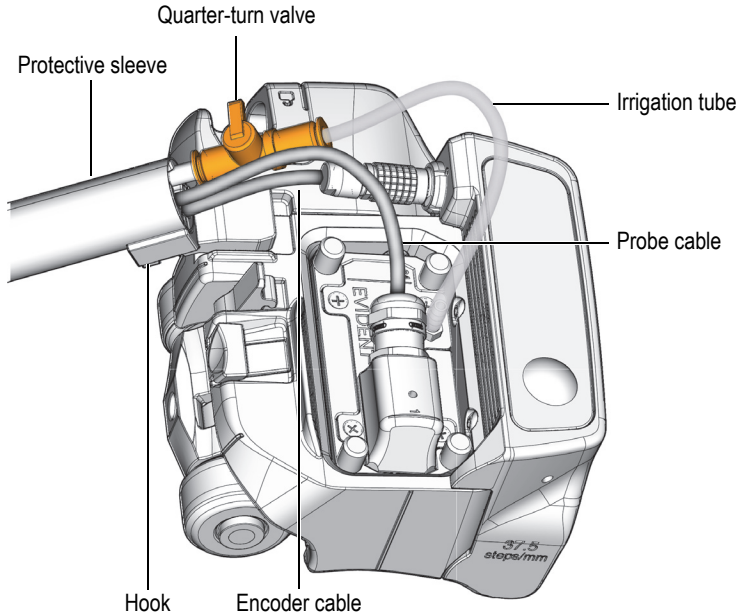
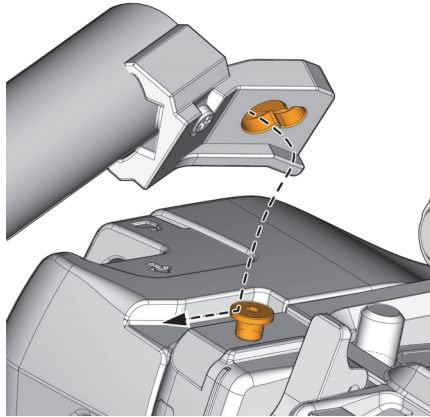

**Figure 1-15 Umbilical and carriage connexions**

### **1.8.1 Umbilical Hook**

The hook features a pin and keyhole mounting point for quick removal and installation.

Slide keyhole in pin then pull back slightly until it clips to secure the umbilical to the carriage (see Figure 1-16 on page 39).



**Figure 1-16 Hooking the umbilical to the scanner**

## **1.8.2 Irrigation Parts**

The irrigation tube is fitted with a quarter-turn valve to stop couplant flow to the probe holder (see Figure 1-15 on page 38).

## **1.8.3 Protective Sleeve**

The tubular protective sleeve is fitted with a full length two-way zipper.



---

## 2. Scanner Setup and Configuration

---

### 2.1 Magnetic Wheel Safety

The magnetic attraction forces around magnetic wheels may pose certain safety risks, depending on use and operating conditions.



#### CAUTION



Magnetic wheel versions of the HydroFORM scanner present a risk of finger crushing if fingers are placed under the wheels that are placed onto a magnetic surface. The magnetic force has a peak of 9286 gauss or 0.9286 tesla at the surface of the wheel. This field quickly drops off to 274 gauss or 0.0274 tesla at a distance of 12 mm (0.5 in.) away from the surface. The magnet does not present any navigational interference risk.

---



#### WARNING



The HydroFORM scanner's magnetic wheels can generate a magnetic field strong enough to affect pacemakers, watches, and other sensitive electronic devices, and anyone wearing or depending on such devices should keep a safe distance away from the HydroFORM scanner to avoid the risk of serious injuries or death. This magnetic field can also demagnetize credit cards, magnetic ID (identification), badges, etc

---



**CAUTION**



Sharp filings or other ferromagnetic objects can be attracted to the magnetic wheels, which can cause equipment malfunction or injuries. It is important to keep the wheels clean (see “Cleaning the Magnetic Wheels” on page 87).

---

## 2.2 Clicker Scan Setup on the ScanDeck Module

This section provides instructions on setting up Clicker mode on the ScanDeck module in an OmniScan X3, MX2, or SX instrument.

### 2.2.1 OmniScan X3 Setup

To set up the HydroFORM scanner in the OmniScan X3 instrument

1. On the **Main** menu, select **Scan**, and then select **Inspection**.
2. Under **Type**, select **Raster Encoded**, and then select **Edit Encoders**.
3. Select the **HydroFORM2** scanner.
4. Select **Index axis encoder**.
5. Change **Type** to **Clicker**.
6. Set the **Resolution** to the beam aperture minus the required overlap.
7. Set a **Preset** value as needed.

### 2.2.2 OmniScan MX2 and SX Setup

To set up the HydroFORM scanner in OmniScan MX2 and SX instruments

1. Set **Inspection** to **Raster scan**.
2. Set **Encoder 1** type to **Quadrature** and **Resolution** to **37.5 steps/mm**.
3. Set **Encoder 2** type to **Clicker** or **Clicker and Preset**, and then set **Resolution** to the beam width value minus the overlap.

## 2.3 Raster Scan Setup on the ScanDeck Module with Index Encoder

This section provides instructions on setting up an encoded raster scan on the ScanDeck module in an OmniScan X3, MX2, or SX instrument.

### 2.3.1 OmniScan X3 Setup

To set up an encoded raster scan in the OmniScan X3 instrument

1. On the **Main** menu, select **Scan**, and then select **Inspection**.
2. Under **Type**, select **Raster Encoder**, and then select **Edit Encoders**.
3. Select the **HydroFORM2** scanner.

To set Guided mode parameters

1. Select the **ScanDeck** tab.
2. Set the **Target Increment** value according to the overlap needed (overlap and beam aperture values are shown as a reference).
3. Set the **Warning Tolerance** value (distance from the index during which the green light remains illuminated).

### 2.3.2 OmniScan MX2 and SX Setup

To set up an encoded raster scan in MX2 and SX instruments

1. Set **Inspection** to **Raster scan**.
2. Set **Encoder 1** type to **Quadrature** and **Resolution** to 37.5 steps/mm.
3. Set **Encoder 2** type to **Quadrature** and **Resolution** to 32 steps/mm.

## 2.4 Raster Scanning Using an Auxiliary Scanner

The HydroFORM scanner can be used in conjunction with auxiliary scanners to perform encoded raster scans (see Table 5 on page 44, Figure 2-1 on page 44, Figure 2-2 on page 45, Figure 2-3 on page 45 and Figure 2-4 on page 46).

**Table 5 Compatible auxiliary scanners**

Scanner	Automation level	Application
ChainSCANNER	Semiautomated	Pipes, 4 in. up to 38 in.
MapSCANNER-Link	Semiautomated	Pipes, 4 in. up to 38 in.
MapSCANNER-Mag	Semiautomated	Ferromagnetic pipes from 4 in. OD and up; pressure vessels and plates
MapROVER	Motorized	Ferromagnetic pipes from 4 in. OD and up; pressure vessels and plates
SteerROVER	Motorized	Remote inspection of ferromagnetic pressure vessels and tanks

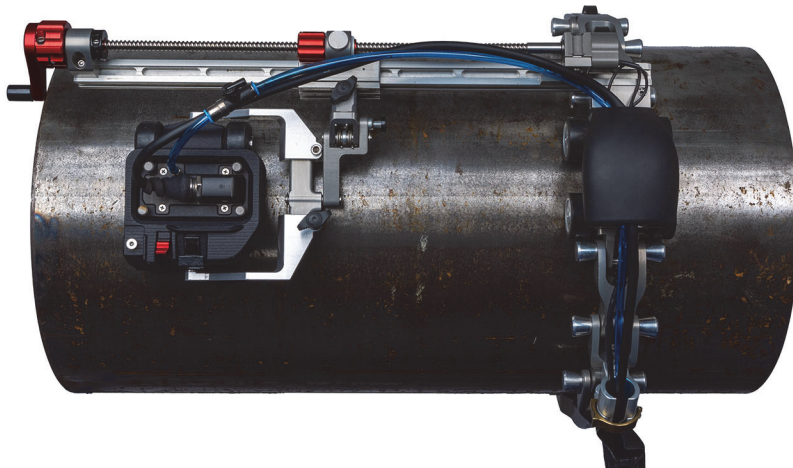
**Figure 2-1 ChainSCANNER system**

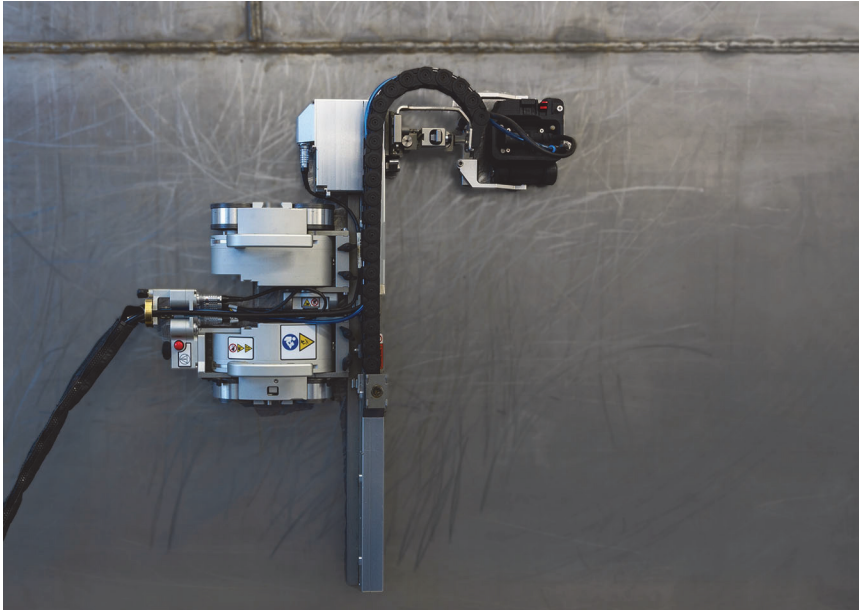



**Figure 2-2 MapSCANNER-Mag system**



**Figure 2-3 MapROVER scanner**



**Figure 2-4 SteerROVER scanner**

The HydroFORM scanner can be purchased in different configurations adapted to the scanners indicated in Table 6 on page 46.

**Table 6 Scanner configurations**

	Scanner compatibility	ScanDeck	Index encoder	Wheel type	Carriage	Umbilical
HydroFORM2 -K-Manual	*See Note.	Yes	Yes	Magnetic	Standard	Yes
HydroFORM2 -K-Manual- Yenc	*See Note.	Yes	No	Magnetic	Standard	Yes
HydroFORM2 -K- ADPCHAIN	ChainSCANNER	No	No	Magnetic	Standard	No
HydroFORM2 -K-SAUT	MapSCANNER	No	No	N/A	Small	No

**Table 6 Scanner configurations (continued)**

	Scanner compatibility	ScanDeck	Index encoder	Wheel type	Carriage	Umbilical
HydroFORM2 -K-AUT	MapROVER/ SteerROVER	No	No	Non-magnetic	Standard	No

**NOTE**

\*Manual HydroFORM configurations require manipulations and/or optional parts to optimize its use on scanners. For details, see “Modifying the Manual HydroFORM Version for Auxiliary Scanners” on page 47.

## 2.4.1 Modifying the Manual HydroFORM Version for Auxiliary Scanners

The manual scanner version of the HydroFORM scanner may need to be modified to be used on an auxiliary scanner. This includes removing or changing parts including the index encoder, ScanDeck module, umbilical, encoder cable and the wheels.

Table 7 on page 47 and Table 8 on page 48 indicate which modifications are necessary to use the HydroFORM scanner with specific scanner models.

See “Removing and Installing the Index Encoder” on page 48, “Removing and Installing the ScanDeck Module” on page 50 and “Changing the Wheels” on page 51 for the steps to make these modifications.

**NOTE**

The following modifications are not required if the HydroFORM configuration was selected beforehand to be compatible with your current auxiliary scanner model.

**Table 7 Modifications for semiautomated auxiliary scanners**

Auxiliary scanner	Index encoder	ScanDeck	Umbilical	Encoder cable	Carriage
ChainSCANNER	Remove	Remove	Remove	Remove	Keep

**Table 7 Modifications for semiautomated auxiliary scanners (continued)**

Auxiliary scanner	Index encoder	ScanDeck	Umbilical	Encoder cable	Carriage
MapSCANNER	Remove	Remove	Remove	Remove	Change to small

**Table 8 Modifications for automated auxiliary scanners**

Auxiliary scanner	Index encoder	ScanDeck	Umbilical	Encoder cable	Wheels
MapROVER	Remove	Remove	Remove	Remove	Change to nonmagnetic
SteerROVER	Remove	Remove	Remove	Remove	Change to nonmagnetic

**IMPORTANT**

Tighten hardware manually with provided tools without using excessive force.

## 2.4.2 Removing and Installing the Index Encoder

### To remove the index encoder

1. Using the supplied 2.5 mm hex key, remove both index encoder assembly mounting screws. See Figure 2-5 on page 49.
2. Gently move the encoder assembly aside and disconnect the encoder from the ScanDeck module. See Figure 2-6 on page 49.

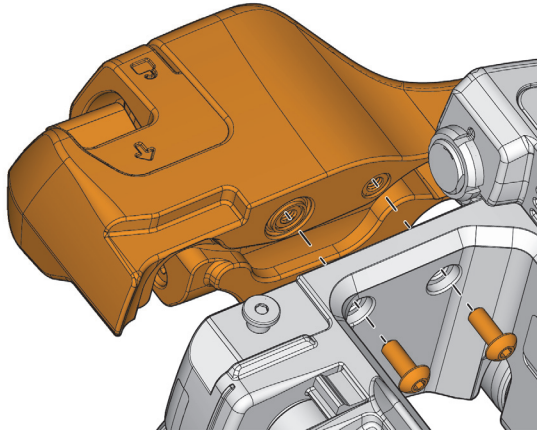

**Figure 2-5 Index encoder removal**

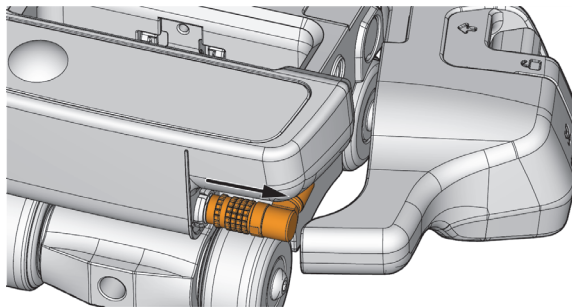

**Figure 2-6 Disconnect encoder cable**

---

**IMPORTANT**

Make sure to install the plug on the encoder ScanDeck connection receptacle.

---

3. Reverse steps for installation. Make sure that the encoder cable is properly routed inside the encoder body. See Figure 2-7 on page 50.

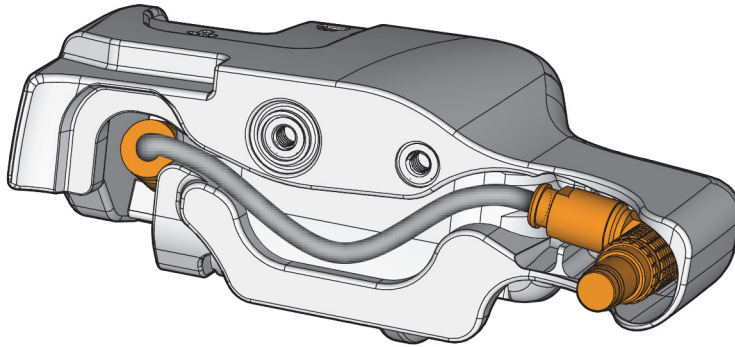

**Figure 2-7 Index encoder cable routing**

### **2.4.3 Removing and Installing the ScanDeck Module**

#### **To remove the ScanDeck module**

1. Disconnect the LEMO connectors.
2. Using the supplied 2.5 mm hex key, remove both mounting screws.

#### **To install the ScanDeck module**

- ◆ To install the ScanDeck module, perform steps 1 and 2 in the removal procedure in reverse order.

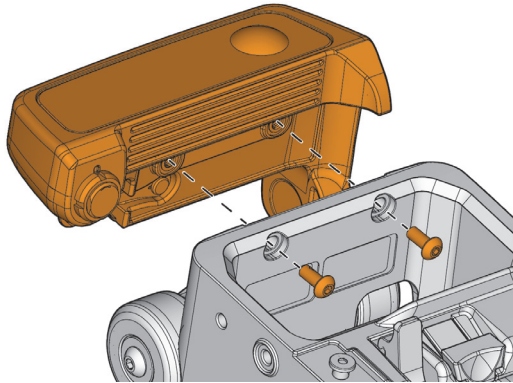

Figure 2-8 ScanDeck removal

#### 2.4.4 Changing the Wheels

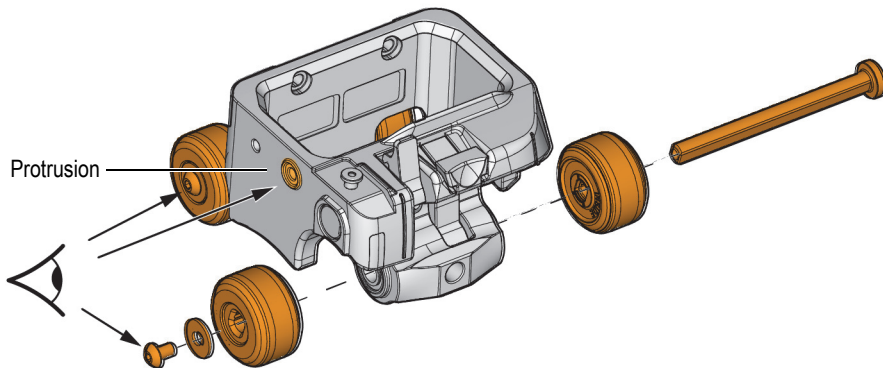

Figure 2-9 Carriage wheels

---

**IMPORTANT**

Assemble the shafts in the proper orientation. Failure to do so will result in loss of encoder signal.

Locate the circular protrusion on the carriage body. In proper orientation, the shaft is inserted from the opposite side, with the wheel mounting screws and washers assembled from the protrusion side. (see arrows, Figure 2-9 on page 51).

---

### To change the wheels

1. Hold one wheel to prevent it from turning while you remove the screw from the end of the axle.
2. Completely remove the shaft to free the other wheel.
3. Slide one wheel onto the shaft. Ensure that the side marked “inside” is facing the carriage.
4. Slide the axle shaft back into the carriage bearings and probe holder lock-release lever. Confirm proper orientation. See Figure 2-9 on page 51.
5. Install the remaining wheel and washer on the axle, and firmly tighten the screw.
6. Repeat steps 1 to 5 to change the wheels on the other axle.

---

**TIP**

Removing the rear wheel shaft also enables you to change the probe lock-release lever.

---



---

## 3. Preparation for Inspection

---

Refer to the following procedures to prepare the scanner for operation.

### 3.1 Changing the Delay Line Height

Water delay line heights of 14 mm and 38 mm are available for a thickness range up to 150 mm in steel.

**Table 9 Delay line thickness range**

<b>Delay line height</b>	<b>Maximum recommended thickness</b>
14 mm	50 mm (2 in.)
38 mm	150 mm (5.9 in.)

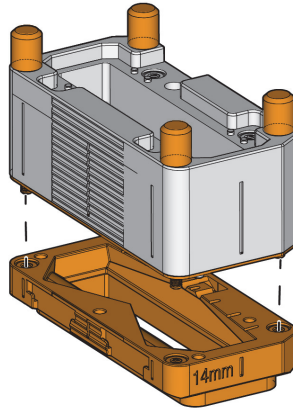

**Figure 3-1** Delay line plate

### To change the delay line height

1. Unscrew the four thumb screws securing the delay line plate to the probe holder (see Figure 3-1 on page 54).
2. Making sure that the probe holder gasket stays in place, align the replacement delay line plate's chamfered corner to the probe holder's chamfered corner and screw the thumb screws in.

## 3.2 Adjusting the Index Encoder Wheel Resistance

Always adjust the index encoder wheel resistance on the current inspection surface. This adjustment will help prevent unwanted drift in the index direction while scanning as well as prevent wheel slippage while indexing.

---

<b>NOTE</b>
-------------

This adjustment is especially important when operating in Freehand mode. In Guided mode, the resistance can be set to the minimum level since the encoder mute function will prevent drift from affecting the index encoder value.

---

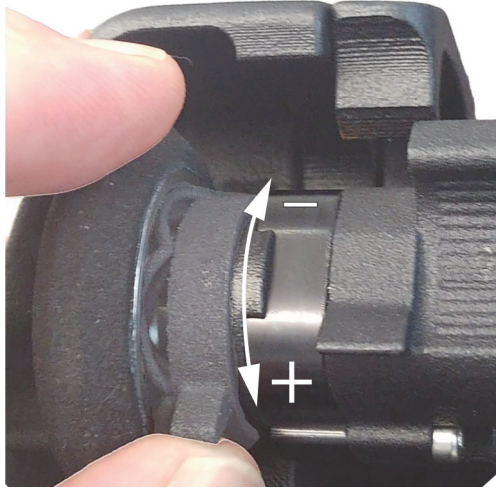

**Figure 3-2 Encoder wheel resistance**

### To adjust the encoder wheel resistance

1. Release the index encoder wheel (see “Stowing and Releasing the Index Encoder” on page 66).
2. Set the scan mode to Freehand. Double clicking the ScanDeck button while in Guided mode switches it to Freehand mode. For additional details, see “Performing a Raster Scan in Freehand Mode” on page 68.
3. Set the wheel resistance to the minimum level (see Figure 3-2 on page 55).
4. Install the scanner on the surface.
5. Long press the ScanDeck button (2 seconds) to reset the encoder values to zero.
6. Roll the scanner along the scan axis, keeping a straight line.
7. At the end of the scan axis scan, the index encoder value will represent the amount of unintended drift of the index encoder. If this value is too high for the application, increase the wheel resistance, and repeat steps 4 to 7 until you have reached an acceptable amount of drift for the application.
8. Validate that the wheel resistance is not too high:
  - a) Long press the ScanDeck button (2 seconds) to reset the encoder values to zero.

- b) From a known starting point, slide the scanner in the index direction for approximately 300 mm (12 in).
- c) Return to the original position, and verify the index encoder value. It should be close to zero. If the error is too significant, lower the wheel resistance.

---

<b>NOTE</b>
-------------

If the right wheel resistance compromise cannot be achieved for the application, we recommend using Guided mode. If Freehand mode is to be used, we recommended stowing the index encoder before moving in the scan direction.

---

### 3.3 Drawing Lines or Marks on the Surface

To facilitate the correct coverage of the surface to be inspected, it is recommended to at least draw starting reference marks.

These marks are used to position the scanner in the index direction and help ensure straight scan lines. If a higher level of precision is required, complete lines can be drawn on the part to facilitate the scanner alignment while scanning.

---

<b>TIP</b>
------------

To help you maintain the scanner on a straight trajectory, the index encoder can be stowed when scanning and released only when indexing.

---

### 3.4 Installing the Foam Gasket Protector

Rough or high-temperature surfaces can lead to faster degradation of the foam gasket. Use the foam gasket protector in these situations.

#### To install the protector

- ◆ Align the chamfered corners of the protector with the delay line plate chamfered corners, and push it to clip all corners of the protector in place.

### To remove the gasket protector

1. Compress the gasket protector onto the probe holder body with one hand (see Figure 3-3 on page 57).
2. With the other hand, insert a fingernail under the protector tab, and slightly pull outwards to release the clip.
3. Repeat for all corners.

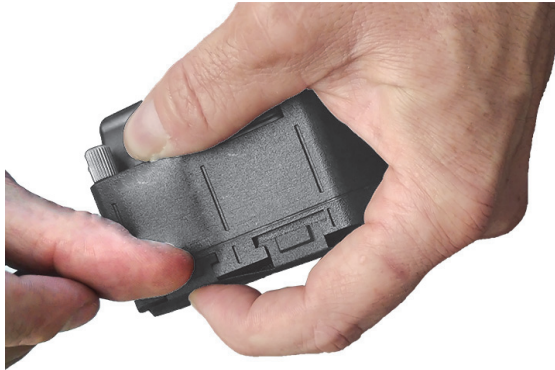

**Figure 3-3 Gasket protector removal**



---

## 4. Operating the HydroFORM Scanner

---

The following sections contain instructions for typical scanner operations.

---

<b>NOTE</b>
-------------

If the index encoder assembly is not installed, make sure to install the plug on the encoder connection receptacle.

Be aware of the safety risks associated with magnetic wheels by reviewing “Magnetic Wheel Safety” on page 41.

---

### 4.1 Hand Positions on the Scanner

When scanning in the scan axis direction, pull the scanner using the grips on the ScanDeck module and the carriage (see Figure 4-1 on page 60).



**Figure 4-1 Scanning hand positions**

When indexing the scanner, put both hands on the side of the scanner and slide it sideways (see Figure 4-2 on page 61).





**Figure 4-2 Indexing hand positions**

## **4.2 Probe Holder Height Adjustment and Water Chamber Filling**

Latching the probe holder lock-release lever secures the probe holder in place.

### **To remove the probe holder or adjust the probe holder height**

1. Disengage the lock-release lever.
2. To remove the probe holder, pull it out of the carriage.
3. To adjust height, slide the probe holder to the desired height and then latch the lock-release lever to secure it.

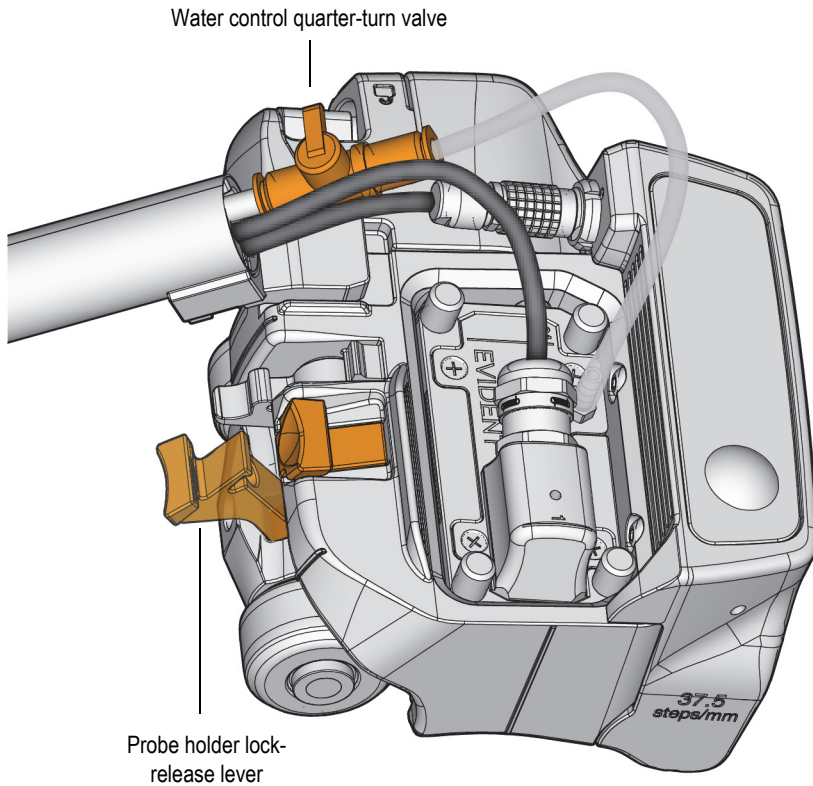
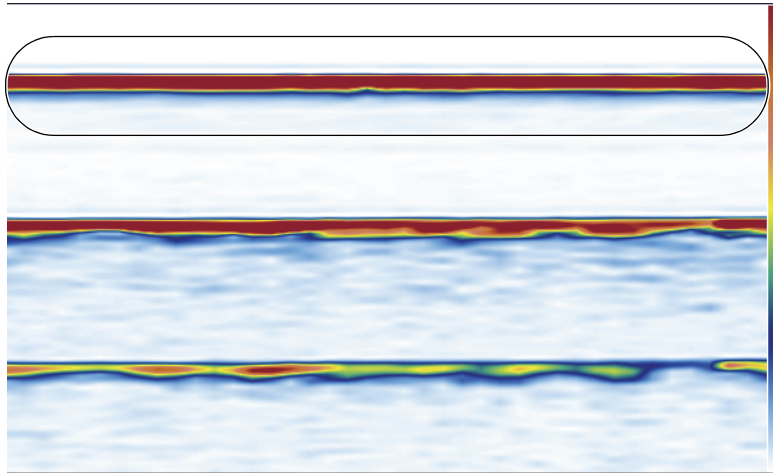

**Figure 4-3 Water control quarter-turn valve and lock-release lever**

### **To fill the water chamber**

1. Place the HydroFORM scanner on a surface.
2. Release the probe lock-release lever.
3. Open the water control quarter-turn valve (see Figure 4-3 on page 62).
4. Apply slight pressure to the probe holder.  
You should be able to hear the bubbles exiting.
5. Lock the probe holder height by latching the lock-release lever.
6. To help clear the remaining bubbles, move the HydroFORM scanner back and forth.

7. Make sure that the S-scan signal is free of bubbles (see Figure 4-4 on page 63).



**Figure 4-4 An example S-scan display**

---

**IMPORTANT**

If the water flow is too high, turbulence could compromise signal integrity.

---

---

**TIP**

- To achieve the desired results, you may need to repeat the above procedure until the signal is good.
  - After each attempt, lift the HydroFORM scanner and empty the water chamber.
  - Bubbles may form on the surface of the probe. To remove any bubbles, wipe the active area of the probe with your finger.
  - The surface condition of the pipe or part determines how much water is required.
  - Better results and faster scan speeds can be achieved using an electric pump providing constant pressure.
-

## 4.3 Validating the Coupling Status Using the ScanDeck Module

The coupling check LED can be used to monitor the coupling status. When used with an OmniScan X3 instrument or later model, the coupling check will be automatically set up when you choose HydroFORM2 on the scanner menu. To set up the coupling check on legacy OmniScan instruments, refer to their respective *User's Manuals*.

The LED will illuminate steady blue when the coupling is good. It will flash blue when at least one VPA A-scan is not crossing Gate I.

---

<b>TIP</b>
------------

To make sure that the coupling check provides valuable feedback, especially on rougher surfaces, you may need to adjust the Gate I threshold and/or adjust the general **Gain** in the OmniScan X3 instrument.

---

## 4.4 Operating the HydroFORM Scanner in Clicker Mode

On the part, mark the position of each scan line in the inspection area before proceeding.

If there is no index encoder connected, the default mode will be Clicker.

If an index encoder is connected, perform an extra long press (8 seconds) on the ScanDeck button to switch from Raster mode to Clicker mode.

---

<b>NOTE</b>
-------------

To know which mode is active, perform a long press (2 seconds) and notice the active ScanDeck LEDs. Refer to the ScanDeck commands quick reference guide copy provided with the scanner and compare the LEDs with the initial status of each mode.

---

### To operate the scanner in Clicker mode

1. Position the scanner on the start or 0,0 position on the surface.
2. Long press the ScanDeck button (2 seconds) to reset the encoder position.

On the ScanDeck, the status LED should be green and both encoder arrows should be off.

3. Push the carriage in the scan axis direction until the scan line is completed.
4. To index, short click the ScanDeck button. The status LED turns red.
5. Slide the scanner sideways (index) up to the next scan line position.
6. Short click the ScanDeck button. The status LED turns green.
7. Pull back the carriage in the scan axis direction to complete the scan line.
8. Repeat as required.

## 4.5 Operating the HydroFORM Scanner in Raster Mode

When the scanner is equipped with an index encoder, the ScanDeck module supports two different raster modes. The default is Guided mode. This mode will automatically mute the encoder that is not in use. It will also provide assistance by visual feedback to guide the operator during indexing.

Performing a double click on the ScanDeck button will toggle between Guided and Freehand modes.

Freehand mode keeps the two encoders active at all times.

In both modes, the index encoder wheel can be stowed to prevent it from dragging on the surface while scanning. Doing so will help you maintain a straight line when scanning and prevent encoder drift in Freehand mode.

### 4.5.1 Performing a Raster Scan in Guided Mode

#### To perform a raster scan in guided mode

1. Position the scanner on the start or 0,0 position on the surface.
2. Long press the ScanDeck button (2 seconds) to reset the encoder position.
3. The initial status shows the scan axis arrow LED lit and the status LED is green.
4. Move in the scan axis direction until the scan line is completed.

---

**IMPORTANT**

Scan in a straight line as the index drift will not be recorded by the index encoder.

---

5. Short click the ScanDeck button. The status LED and scan arrow turn off, and the index axis arrow LED turns on.
  6. Slide the scanner sideways. When the index value is reached, the status LED will turn green.
  7. If the index position is passed the target value, the status LED will turn RED. It is then recommended to slide the scanner in the reverse direction until the LED turns green again. Failure to do so will result in missed data.
  8. Short click the ScanDeck button. Scan axis arrow LED will turn on and index axis arrow will turn off.
  9. Pull back in the scan axis direction until the scan line is complete.
  10. Repeat as required.
- 

**NOTE**

Only the illuminated arrow direction is encoded.

---

## 4.5.2 Stowing and Releasing the Index Encoder

### To stow the index encoder

- ◆ Push the encoder thumb grip up until it clips on the release tab (see Figure 4-5 on page 67).

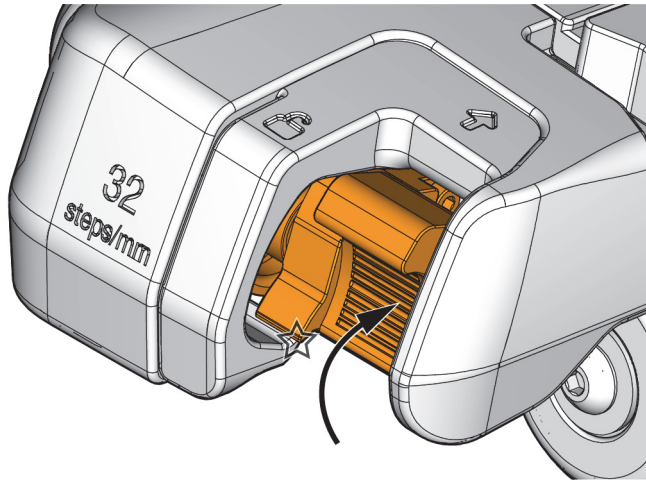

**Figure 4-5 Index encoder stowed**

#### **To release the encoder wheel**

- ◆ Pull outwards on the release tab (see Figure 4-6 on page 67 and Figure 4-7 on page 68).

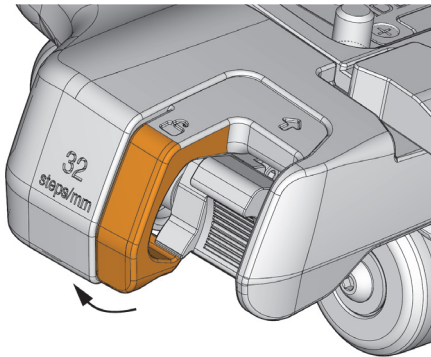

**Figure 4-6 Index encoder release tab**



**Figure 4-7 Index encoder operation**

### **4.5.3 Performing a Raster Scan in Freehand Mode**

#### **To perform a raster scan in Freehand mode**

1. While in Guided mode, double click the ScanDeck button to switch into Freehand mode.  
The two arrow LEDs will be illuminated and the status LED will be green (see “ScanDeck control pad” on page 31 and see “ScanDeck Commands” on page 117).
2. Make sure to move the scanner in straight, 90 deg lines on either the scan or index axis while you perform your raster scan. In Freehand mode, each encoder will measure the scanner movement as long as the scanner is moved orthogonally. For accurate recording of the scan position, move in one direction at a time. Do not move diagonally.

---

<b>NOTE</b>
-------------

When performing Freehand scanning, it is recommended to adjust the index encoder wheel resistance. For details, see “Adjusting the Index Encoder Wheel Resistance” on page 54.

---



---

**TIP**

Set the **Area** in the OmniScan to a negative value for the **Index start**. This will allow for some index encoder drift during the first scan line.

---

Although optional, the index position guiding function (Guided mode) is also available while in Freehand mode (see “Performing a Raster Scan in Guided Mode” on page 65).



---

## 5. Maintenance

---

This chapter provides procedures to perform standard maintenance on the HydroFORM scanner.

---

<b>NOTE</b>
-------------

Before performing maintenance procedures:

- Disconnect the scanner from the instrument.
- To prevent water intrusion, keep cables connected on the scanner.
- If the index encoder assembly is not installed, make sure to install the plug on the encoder connection receptacle.

Be aware of the safety risks associated with magnetic wheels by reviewing “Magnetic Wheel Safety” on page 41.

---



<b>CAUTION</b>
----------------

Tighten hardware manually using the provided tools and without using excessive force.

---

### 5.1 Cleaning the Unit

The HydroFORM external surfaces can be cleaned when needed. This section provides the procedure for the appropriate cleaning of the product.

---

## To clean the unit

---



### CAUTION

Do not use abrasive products or powerful solvents that could damage the finish.

---

1. Disconnect the scanner from the data acquisition instrument.
  2. To prevent water intrusion, keep the cables connected on the scanner.
- 

### NOTE

If the index encoder assembly is not installed, make sure to install a plug on the encoder receptacle.

---

3. To bring the unit back to its original finish, clean the housing with a soft cloth.
  4. To remove persistent stains, use a damp cloth with a soft, soapy solution.
  5. Wait until the unit is completely dry before disconnecting the cables.
- 

### NOTE

To clear the water circulation holes, use a thin metal wire or compressed air.

---

## 5.2 Replacing the Foam Gasket on the Delay Line Plate

The HydroFORM kit comes with several spare foam gaskets and protectors. The kit also includes four standard delay line plates and one delay line plate for thick material.

In order to reduce downtime, the plates can be fitted in advance with new foam gaskets.

These gaskets can be quickly changed during the inspection if necessary (see Figure 5-1 on page 73). For the delay line plate specifications, see “General Specifications” on page 89.

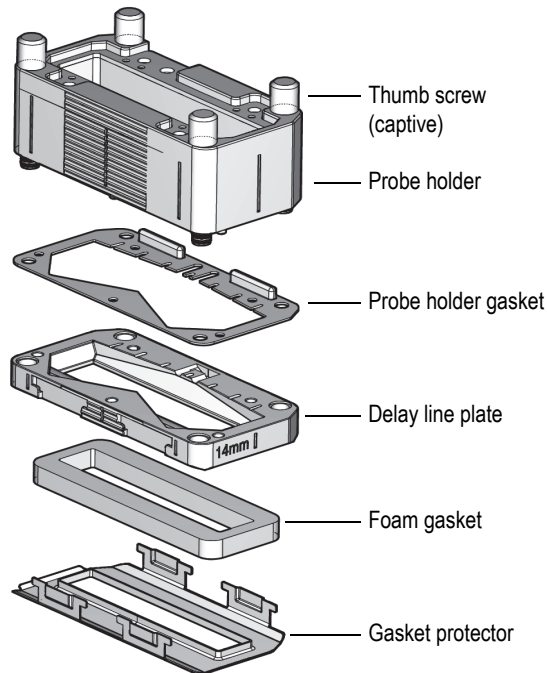

**Figure 5-1 Probe holder exploded view**

### To replace a foam gasket

1. Loosen the captive thumb screws on the probe holder.
2. Remove the delay line plate.
3. Use the provided scraper to remove the old foam and adhesive from the delay line plate.



### CAUTION

The delay line plate must be removed from the probe holder before attempting to remove the gasket. Failure to do so could damage the phased array probe.

4. Use a cloth to remove any adhesive residue remaining on the delay line plate.
5. Peel the protective backing from the new foam adhesive pad.

6. Install the new foam pad onto the delay line plate (see Figure 5-2 on page 74).

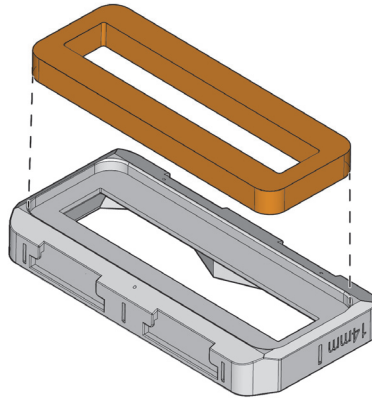

**Figure 5-2 New foam and delay line plate**

7. Make sure that the probe holder gasket is well fitted under the probe holder body.
8. Place the delay line plate under the probe-holder assembly with the corners properly aligned (see Figure 5-3 on page 74).

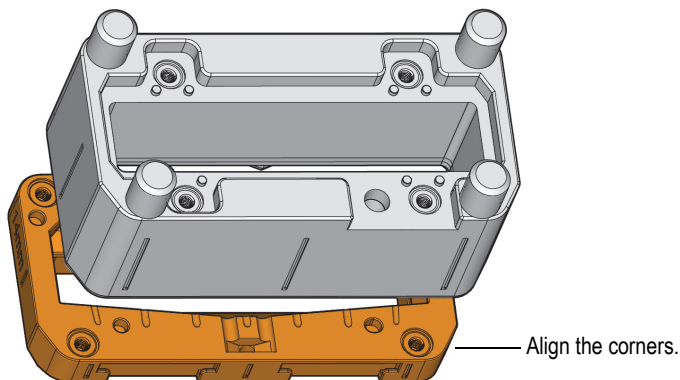

**Figure 5-3 Installing the delay line plate on the probe-holder**

**TIP**

The corner chamfers are not symmetrical to ensure that the delay line plate and probe holder match when installed in the correct orientation.

---

9. Tighten the four thumb screws.
10. Reinstall the probe holder assembly into the carriage.

### 5.3 Cleaning the Delay Line Vent Holes

The three delay line cavities and vent holes may become obstructed and require cleaning (see Figure 5-4 on page 76).

---

**TIP**

An indication of obstructed delay line vents include having trouble filling the water chamber, poor water flow and difficult bubble removal.

---

**IMPORTANT**

We recommend using a soft dental plastic pick with bristles or flexible metallic wire. The maximum diameter of the solid section of the tool must be 0.7 mm (0.027 in.) or smaller.

---

**CAUTION**

Do not enlarge the vent holes while cleaning. Enlarging the holes will reduce water chamber filling performance. Do not use tools like needles or small screwdrivers as the tapered shape could enlarge the hole.

---

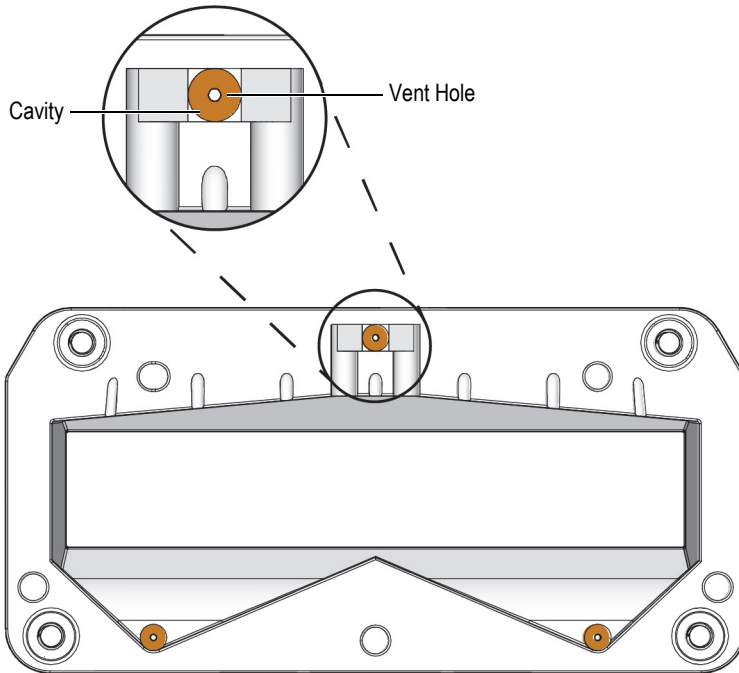

**Figure 5-4 Delay line vents**

### **To clean the delay line vents**

1. Remove delay line from the probe holder (see “Changing the Delay Line Height” on page 53).
2. Keep the probe holder gasket for re-installation.
3. Remove the gasket protector if it is installed (see “Installing the Foam Gasket Protector” on page 56).
4. Clean the cavity by scraping the sides and bottom to dislodge any debris (see Figure 5-4 on page 76).
5. Clean repeatedly with water or compressed air, making sure debris are removed from the plate so they do not migrate back in the cavity.
6. Hold the delay line against a light source to confirm the three vent holes are unobstructed.



7. Reassemble the delay line plate, probe holder gasket to the probe holder (see “Changing the Delay Line Height” on page 53).
8. Reassemble the gasket protector (see “Installing the Foam Gasket Protector” on page 56).

## 5.4 Replacing the Probe

### To replace the probe

1. Release the lock-release lever to remove the probe holder from the scanner.
2. Remove the four screws that secure the probe to the probe holder (see Figure 5-5 on page 77).

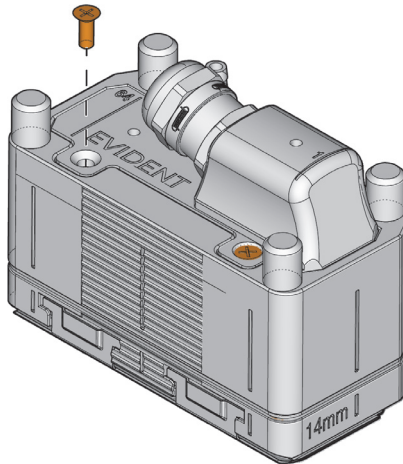

Figure 5-5 Probe retaining screws

3. Pull the probe up by the protrusion on the probe casing (see Figure 5-6 on page 78).



### CAUTION

DO NOT pull on the probe cable. Doing so could damage the phased array probe. Pull the probe by the probe casing (see Figure 5-6 on page 78).

---

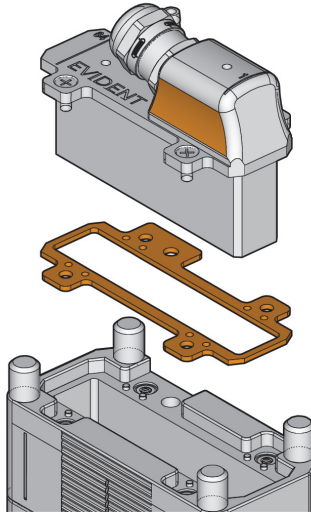

**Figure 5-6 Probe and gasket**

4. Perform this procedure in the reverse order to replace the probe in the probe-holder. Do not over tighten the screws.

When the probe is being replaced, it is important to reinstall the gasket underneath the probe's flange (see Figure 5-6 on page 78).

## 5.5 Changing the Brake Pad

The brake pad is pressed on the carriage body. Follow this procedure to change the brake pad. Before beginning, remove the index encoder if it is installed (see "Removing and Installing the Index Encoder" on page 48).

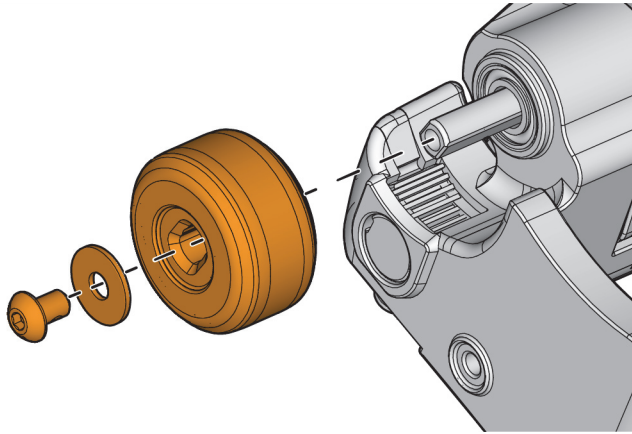

**Figure 5-7 Wheel removal**

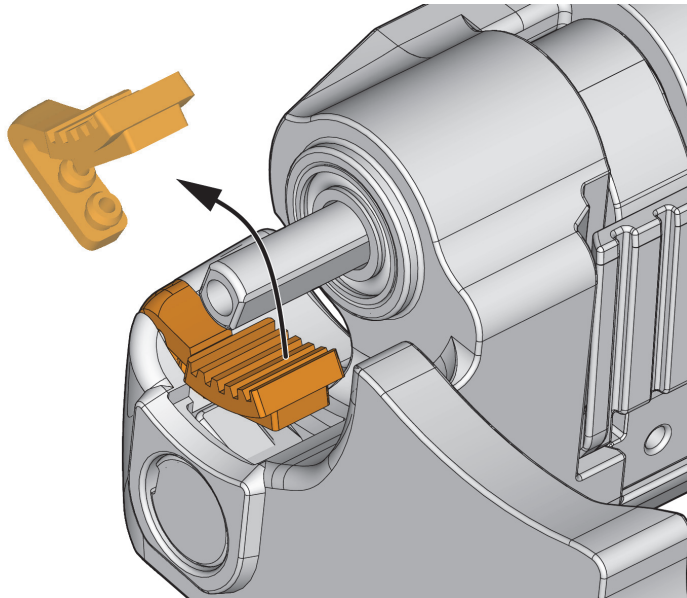

**Figure 5-8 Brake pad removal**

## To change the brake pad

1. Place the scanner upside down.
2. Remove the wheel above the brake pad (see Figure 5-7 on page 79).
3. Lift the brake pad and pull outwards to remove it from the mounting points (see Figure 5-8 on page 79).
4. Install the new brake pad, making sure that the pad is firmly pressed in the mounting points and well positioned above the wheel.
5. Reinstall the wheel you removed in step 2.

## 5.6 Removing the Brake Shaft and Brake Lever

The brake shaft has a spring key that clips on the brake lever.

Removing the brake shaft enables you to remove the brake lever.

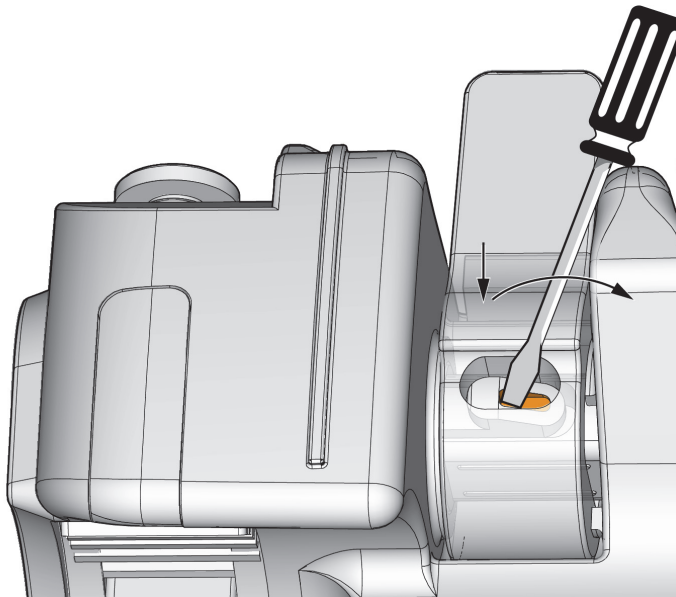

**Figure 5-9 Brake shaft key slot**

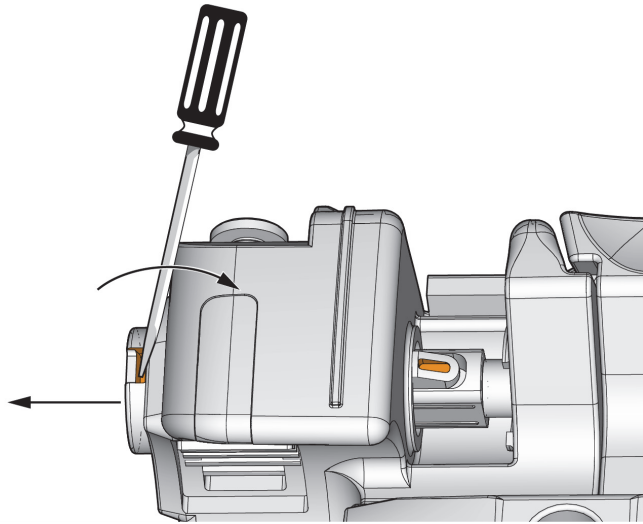
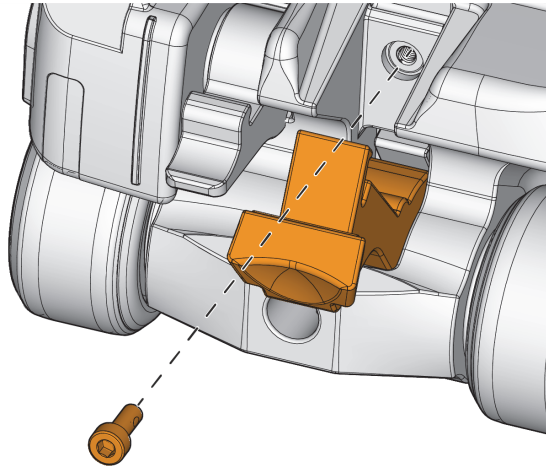

**Figure 5-10 Brake shaft removal**

### **To remove the brake shaft and lever**

1. Lift the brake lever.
2. Locate the key slot. It is visible inside the brake lever hole.
3. Insert a flat screwdriver tip in the smaller shaft key slot (see Figure 5-9 on page 80).
4. Depress the shaft key and tilt screwdriver inwards to push the shaft outwards (see the arrows in Figure 5-9 on page 80).
5. Insert the screwdriver tip in the cavity on the shaft end. Tilt inwards to push shaft out (see the arrows in Figure 5-10 on page 81).
6. To install the brake shaft, place the lever on carriage, and push the shaft inwards until the shaft key clicks in the lever slot.

## 5.7 Changing the Probe Holder Lock-Release Pad



**Figure 5-11** Probe holder lock-release pad retaining screw

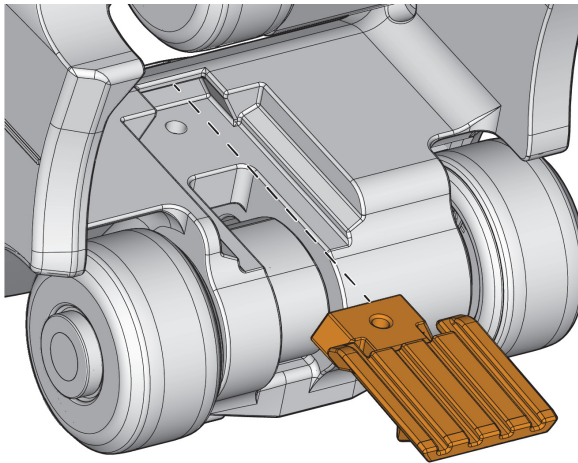

**Figure 5-12** Probe holder lock-release pad removal

## To change the probe holder lock-release pad

1. Disengage the lock-release lever to reveal the retaining screw.
2. Remove the screw, and set it aside for re installation (see Figure 5-11 on page 82).
3. From the bottom of the carriage, slide the pad out of the dovetail (see Figure 5-12 on page 82).
4. To install a pad, perform steps 1 to 3 in the reverse order.

## 5.8 Index Encoder Maintenance

The index encoder housing is mounted to the carriage by two screws.

For removal instructions, see “Removing and Installing the Index Encoder” on page 48.

### 5.8.1 Changing the Index Encoder Assembly

You will need the 2 mm hex key to perform this procedure.

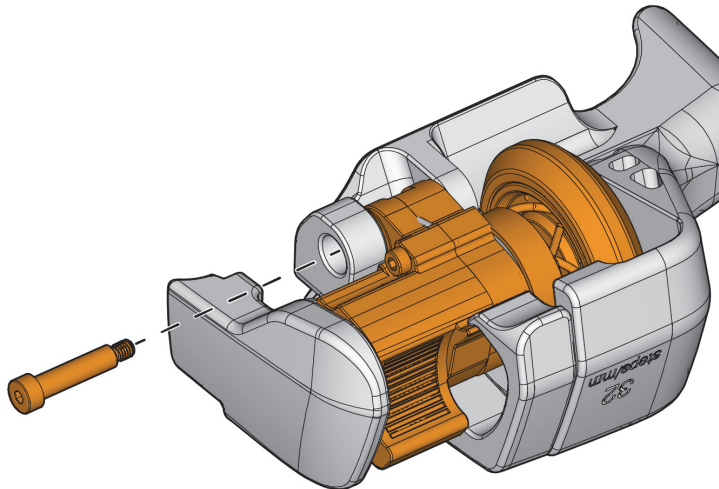
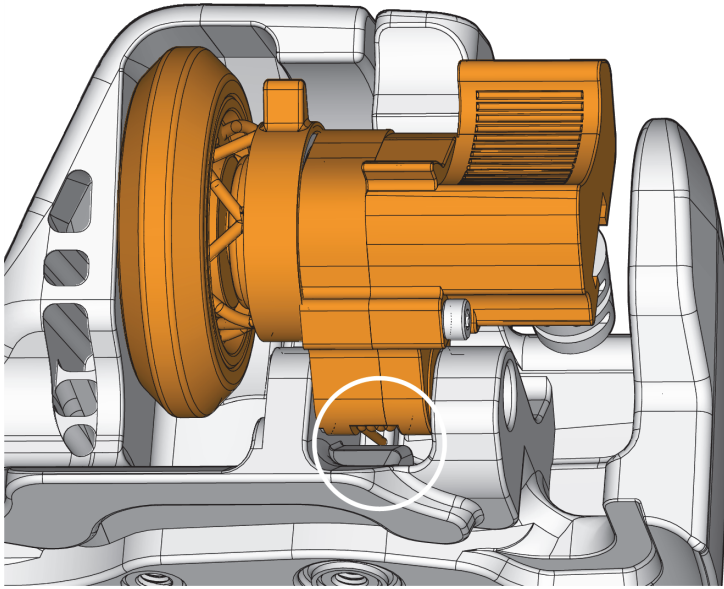

Figure 5-13 Index encoder assembly shoulder screw



**Figure 5-14 Spring placement**

### **To change the index encoder**

1. Place the scanner upside down.
2. Unscrew the shoulder screw, and then push it out from the other side (see Figure 5-13 on page 83).
3. Lift the index encoder assembly out of the housing.
4. To reinstall the index encoder assembly, check the spring placement against the housing wall, and compress the spring as you insert the assembly (see Figure 5-14 on page 84).
5. Align the holes for the shoulder screw and insert it back in and screw it to secure the index encoder assembly in place.



## 5.8.2 Changing the Index Encoder Wheel

### To change the index encoder wheel

1. Hold the encoder wheel to prevent it from turning, and remove the screw (see Figure 5-15 on page 85).
2. To install the wheel, align the flat edges on shaft and wheel, press the wheel onto the shaft to compress the friction ring, and then install the screw (see Figure 5-16 on page 86).

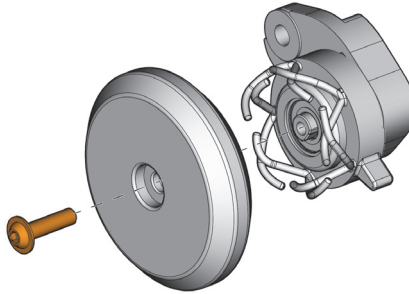
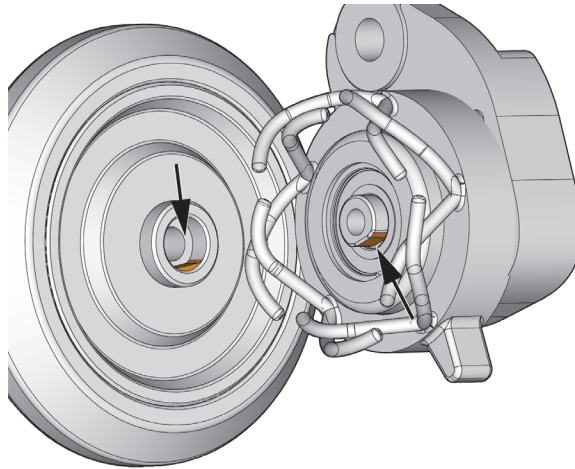

Figure 5-15 Index encoder wheel screw



**Figure 5-16 Wheel and shaft flats**

### **5.8.3 Changing the Friction Ring**

1. To remove the friction ring, align the step ring pin with the internal groove on the friction ring and pull outwards (see Figure 5-17 on page 86).
2. To install, align the pin to the friction ring groove then press the friction ring onto the step ring (see Figure 5-17 on page 86).

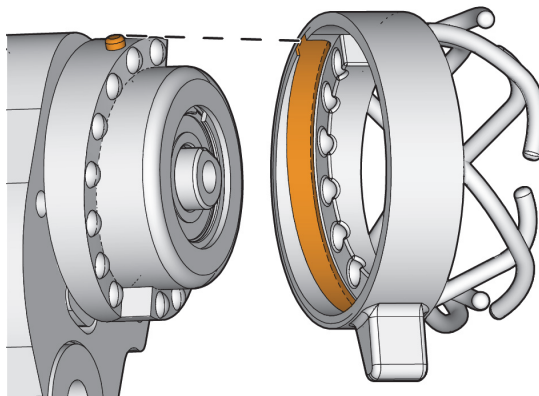

**Figure 5-17 Friction ring and step ring**

---

## 5.9 Cleaning the Magnetic Wheels

The magnetic wheels can attract sharp filings or other ferromagnetic objects. The wheels need periodic cleaning to avoid accumulation of any foreign objects that can cause injuries or equipment malfunction. The cleaning frequency depends on your operating conditions.

### Required materials:

- Work gloves
- Clean cloth



**WARNING**



To avoid injuries or equipment damage when handling magnetic wheels, take note of the magnetic attraction forces around the wheels, and observe the safety notes outlined in “Magnetic Wheel Safety” on page 41.

---

### To clean the magnetic wheels

1. Put on your work gloves.
2. While turning the wheel, hold the clean cloth against it to remove particles.
3. Repeat the above step for each wheel.



## 6. Specifications

### 6.1 General Specifications

**Table 10 Specifications**

Parameter	Value
<b>General</b>	
Dimensions (L × W × H)	14 cm × 12.1 cm × 8.5 cm (5.5 in. × 4.8 in. × 3.3 in.) without index encoder 16 cm × 14 cm × 8.5 cm (6.3 in. × 5.5 in. × 3.3 in.) with index encoder
Weight	1.1 kg (2.4 lb) without index encoder (excluding cables) 1.4 kg (3.1 lb) with index encoder (excluding cables)
Inspection surface curvature	From 114 mm (4 in.) minimum diameter up to a flat surface (circumferential scan)
Probe	Type: I8 64 elements Pitch: 1 mm Elevation: 3 mm Cable length: 7.5 m (24 ft) Center frequency: 7.5 MHz
Minimum height clearance	90 mm (3.5 in.)
Magnetic field strength of wheels	0.99 milligauss at a distance of 2.1 m (7 ft) from the wheels (below the 2 milligauss limit at which restrictions would be imposed on air shipment)

**Table 10 Specifications (continued)**

<b>Parameter</b>	<b>Value</b>
Encoder	Recommended scanning speed: variable, dependent on OmniScan instrument and application setup used.
	Type: Quadrature
	Scan axis resolution: 37.5 steps/mm
	Index axis resolution: 32 steps/mm
	Pinout: see "Cable Pinout and Connector Reference" on page 91.
	Voltage: 5 VDC Maximum current: 100 mA
	CLK frequency: 1 MHz
<b>Environment</b>	
Outdoor use	Yes
Altitude	Up to 2000 m (6562 ft)
Operating temperature	5 °C to 50 °C (41 °F to 122 °F)
Maximum inspection surface temperature	90 °C (194 °F) (with water flow turned on and foam gasket protector installed)
Storage temperature	-30 °C to 60 °C (-22 °F to 140 °F)
Relative humidity (RH)	Standard MIL-STD-810G, Method 507.5 Procedure II, Figure 507.5-7
Pollution level	2
IP rating	IP57
High temperature operating	Standard MIL-STD-810H, Method 501.7 Procedure II, §4.5.3
Low temperature operating	Standard MIL-STD-810H, Method 502.7 Procedure II, §4.5.3
High temperature storage	Standard MIL-STD-810H, Method 501.7 Procedure I, §4.5.2
Low temperature storage	Standard MIL-STD-810H, Method 502.7 Procedure I, §4.5.2
Thermal shock	Standard MIL-STD-810H, Method 503.7 Procedure I-C, Figure 503.7-3
Humidity storage	Standard MIL-STD-810H, Method 507.6 Procedure II, Figure 507.6-7

## 6.2 Cable Pinout and Connector Reference

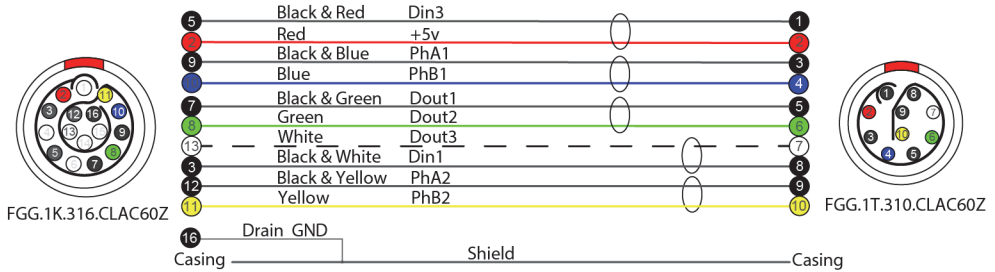

Figure 6-1 Cable pinout and connector reference

## 6.3 Digital Signal Assignment

Table 11 Digital signal assignment

Action	Din	Dout	Pin number (scanner)	Pin number (instrument)
Start/Clear all	1		8	3
Clicker	3		1	5
Coupling check		1	5	7
Green LED		2	6	8
Red LED		3	7	13

## 6.4 Dimensions and Clearances

Dimensions appearing in this section show inches as the base unit and millimeters between brackets.

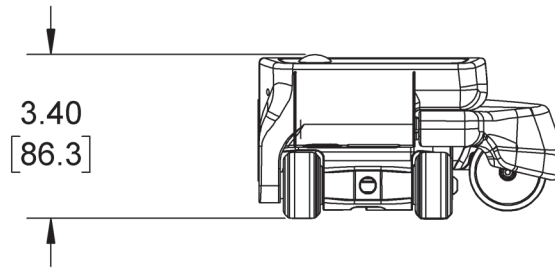

Figure 6-2 HydroFORM front view dimensions

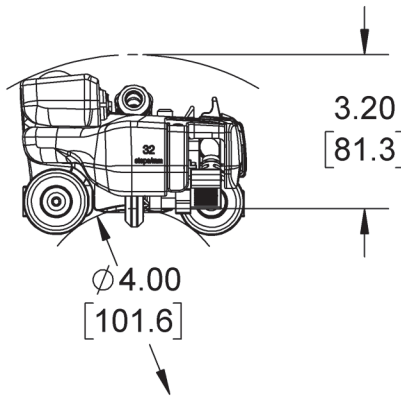

Figure 6-3 HydroFORM left side view dimensions



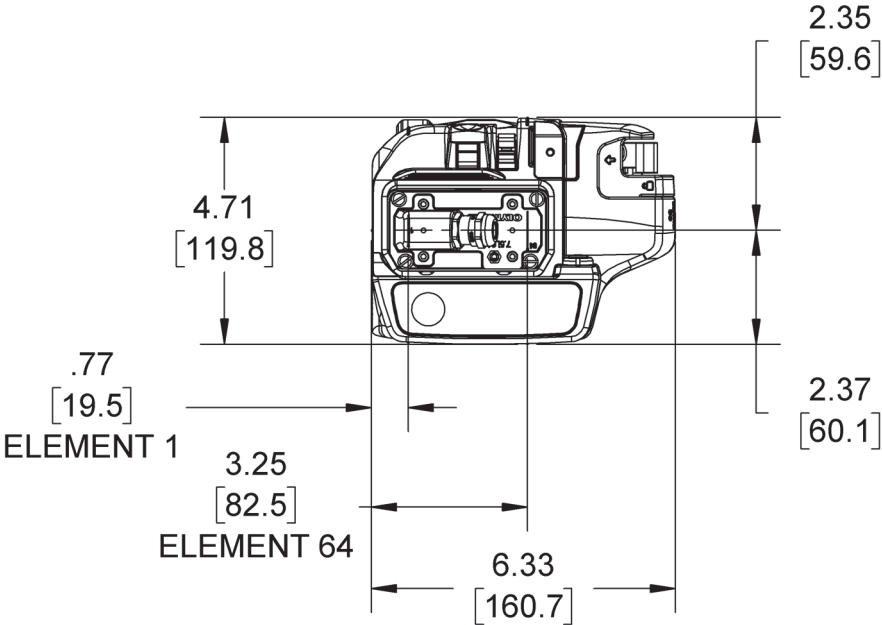
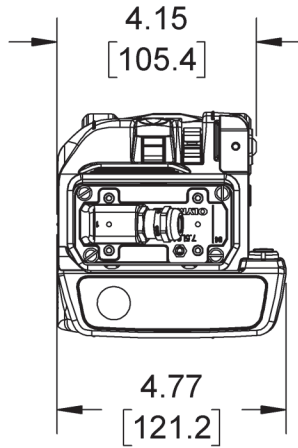
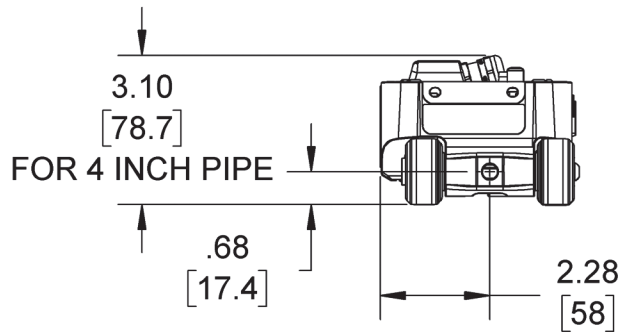

Figure 6-4 HydroFORM top view dimensions with index encoder



**Figure 6-5 HydroFORM top view dimensions, no index encoder**



**Figure 6-6 HydroFORM front view dimensions, no index encoder, no ScanDeck**

---

## 7. Spare Parts and Accessories

---

### 7.1 HydroFORM Scanner Spare Parts

In this section, you will find spare parts and kits for the HydroFORM scanner as well as the part number to order them.

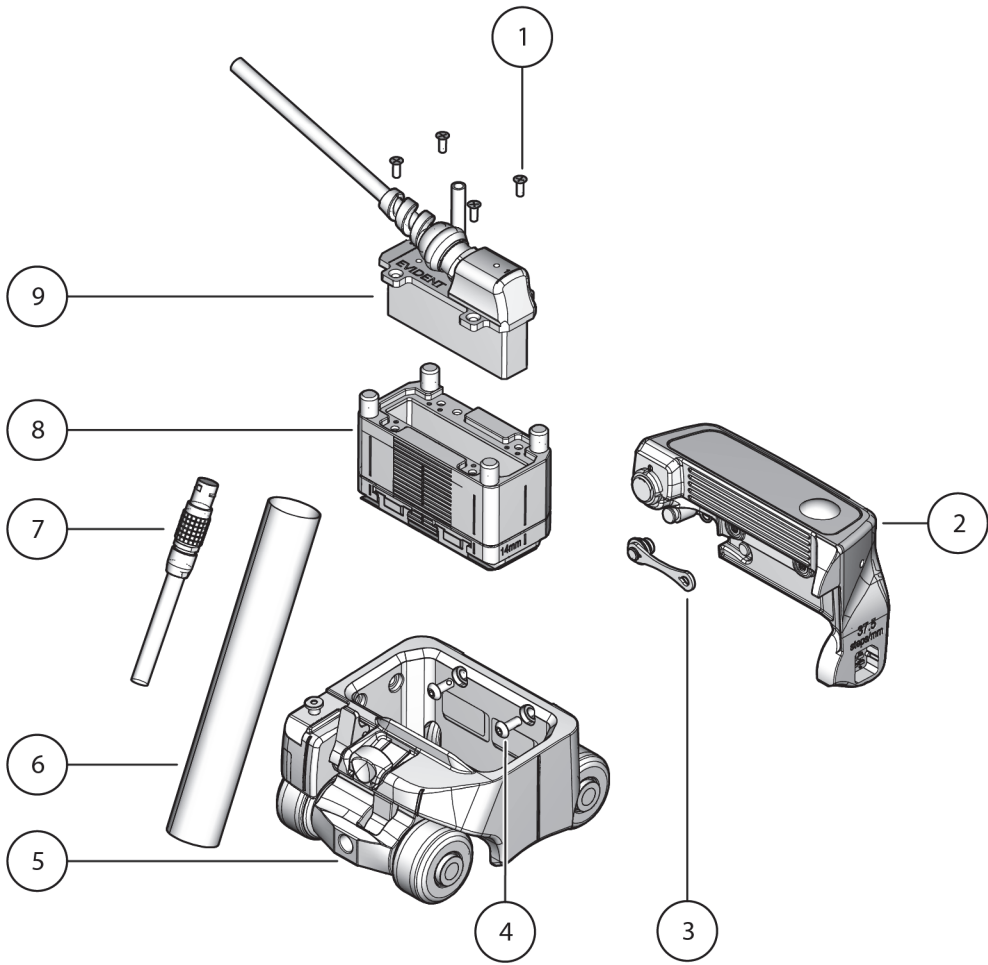

Figure 7-1 HydroFORM General exploded view

Table 12 General parts list

Item	Qty	Part number	Description
1	4	Q8301772	SOCKET HEAD SCREW SS M3 × 0.5 MM, 8 MM
2	1	Q8302237	SCAN DECK FOR HYDROFORM 2

**Table 12 General parts list (continued)**

<b>Item</b>	<b>Qty</b>	<b>Part number</b>	<b>Description</b>
3	1	Q8302260	DUSTCAP FOR SCANDECK
4	4	Q8302238	BUTTON SCREW HEX M4 × 0.70MM 18-8 SST 10MM
5	1	Q8302240	HYDROFORM 2 BUGGY ASSEMBLY
6	1	Q8302241	HYDROFORM 2 ZIPPER TUBE 7.5M
	1	Q8302242	HYDROFORM 2 ZIPPER TUBE 15M
7	1	Q8302244	HYDROFORM 2 ENCODER CABLE 7.5M
	1	Q8302245	HYDROFORM 2 ENCODER CABLE 15M
	1	Q8302246	HYDROFORM 2 ENCODER CABLE 25M
8	1	Q8302239	WATERBOX ASSEMBLY FOR HYDROFORM 2
9	1	Q3302221	PHASED ARRAY PROBE, 7.5 MHZ LINEAR ARRAY, 64 ELEMENTS 7.5 M CABLE LENGTH
	1	Q3302222	PHASED ARRAY PROBE, 7.5 MHZ LINEAR ARRAY, 64 ELEMENTS 15 M CABLE LENGTH
	1	Q3302223	PHASED ARRAY PROBE, 7.5 MHZ LINEAR ARRAY, 64 ELEMENTS 30 M CABLE LENGTH

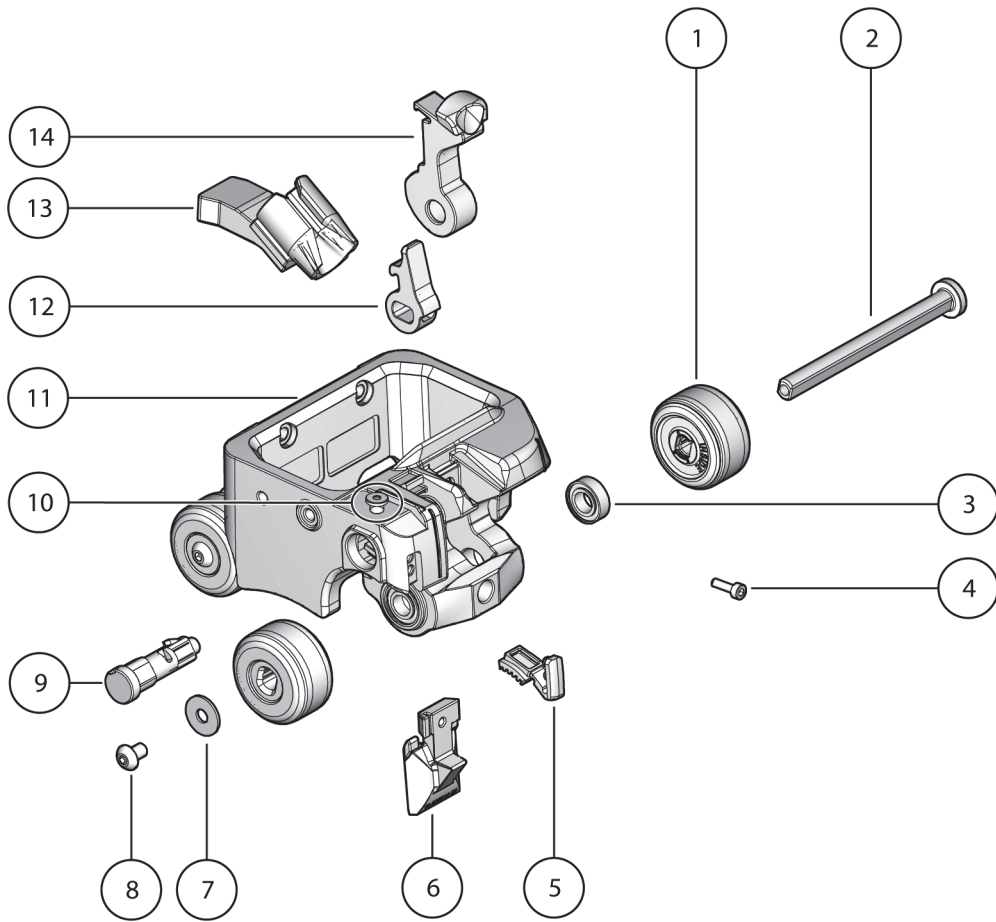

Figure 7-2 Carriage exploded view

Table 13 Carriage

Item	Qty	Part number	Description
1	4	Q8302248	HYDROFORM 2 MAGNETIC WHEEL
	4	Q8302297	HYDROFORM 2 NON-MAGNETIC WHEEL
2	2	Q8302247	WHEEL SHAFT INCLUDING MAGNET

**Table 13 Carriage (continued)**

<b>Item</b>	<b>Qty</b>	<b>Part number</b>	<b>Description</b>
3	4	Q8302249	BEARING ID-8MM OD-16MM W-5MM
4	1	Q8302250	SCREW SOCKET HEAD SS M3 × 0.5 MM, 10 MM
5	1	Q8302254	HYDROFORM 2 LINING BREAK
6	1	Q8302252	PAD TIGHTENING INCLUDING FIXATION SCREW AND WASHERS
7	4	Q8302256	FLAT WASHER M5 OD-15MM STAIN
8	4	Q8302255	BUTTON SCREW SOCKET HEAD THR-LOCK M5 × 8MM
9	1	Q8302257	HYDROFORM 2 SHAFT W CAM FOR BRAKE
10	1	Q8302261	SHOULDER SCREW M4 5 × 4MM
11	1	Q8302258	HYDROFORM 2 FRAME
12	1	Q8302253	HYDROFORM 2 BRAKE LEVER
13	1	Q8302259	HYDROFORM 2 CABLES ANCHOR ASSEMBLY
14	1	Q8302251	HYDROFORM 2 CAM ASSEMBLY INCLUDING BEARINGS

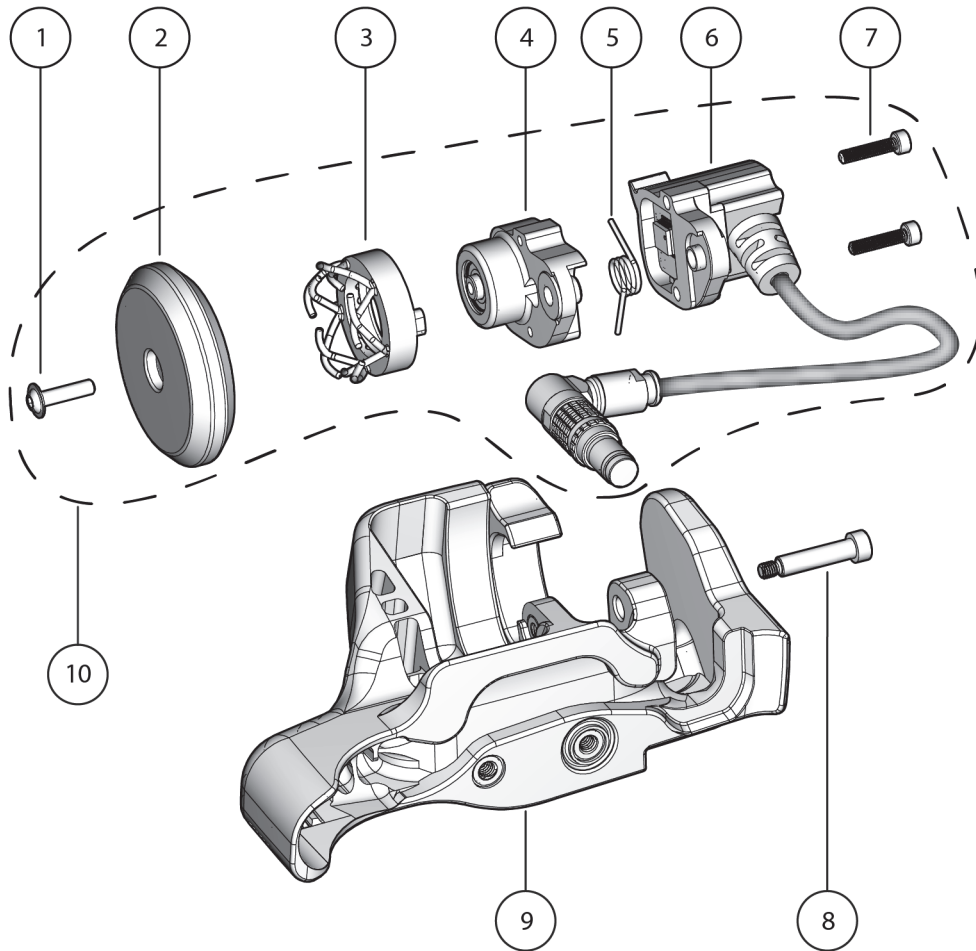

Figure 7-3 Index Encoder exploded view

Table 14 Index encoder

Item	Qty	Part number	Description
1	1	Q8302262	SCREW BHC FLG M3 x 12MM FT 18-8 SST
2	1	Q8302285	HYDROFORM 2 WHEEL FOR INDEX ENCODER



**Table 14 Index encoder (continued)**

Item	Qty	Part number	Description
3	1	Q8302264	HYDROFORM 2 ENCODER PRESSURE RING KIT
4	1	Q8302265	ENCODER CASING WITH BEARINGS AND MAGNET
5	1	Q8302266	SPRING TORSION 90 DEG 0.309 IN OD
6	1	Q8302267	HYDROFORM 2 ELECTRONIC CASING
7	2	Q0200585	SCREW SOCKET HEX M2.5 × 0.45 × 12 18-8SS
8	1	Q8301731	SHOULDER SCREW M3-0.5 Ø4 × 16MM HEX
9	1	Q8302268	HYDROFORM 2 SUPPORT INDEX ENCODER
10	1	Q8302269	HYDROFORM 2 INDEX ENCODER REPLACEMENT

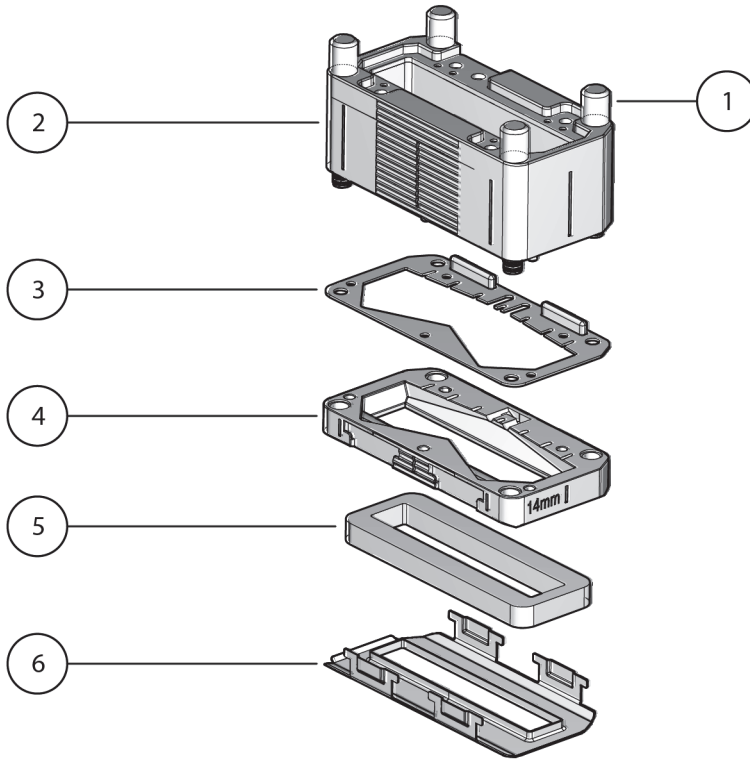

**Figure 7-4 Probe Holder exploded view**

**Table 15 Probe holder**

Item	Qty	Part number	Description
1	4	Q8302270	HYDROFORM 2 WATERBOX THUMB SCREW
2	1	Q8302271	HYDROFORM 2 WATER BOX
3	1	Q8302272	WATERBOX GASKET
4	1	Q8302273	DELAY LINE 14MM
		Q8302274	DELAY LINE 38MM
5	1	Q8300883	GASKET FOAM 1/4 INCH
	-	U8775184	GASKET FOAM 1/4 INCH KIT OF 100

**Table 15 Probe holder (continued)**

Item	Qty	Part number	Description
6	1	Q8302275	GASKET PROTECTOR

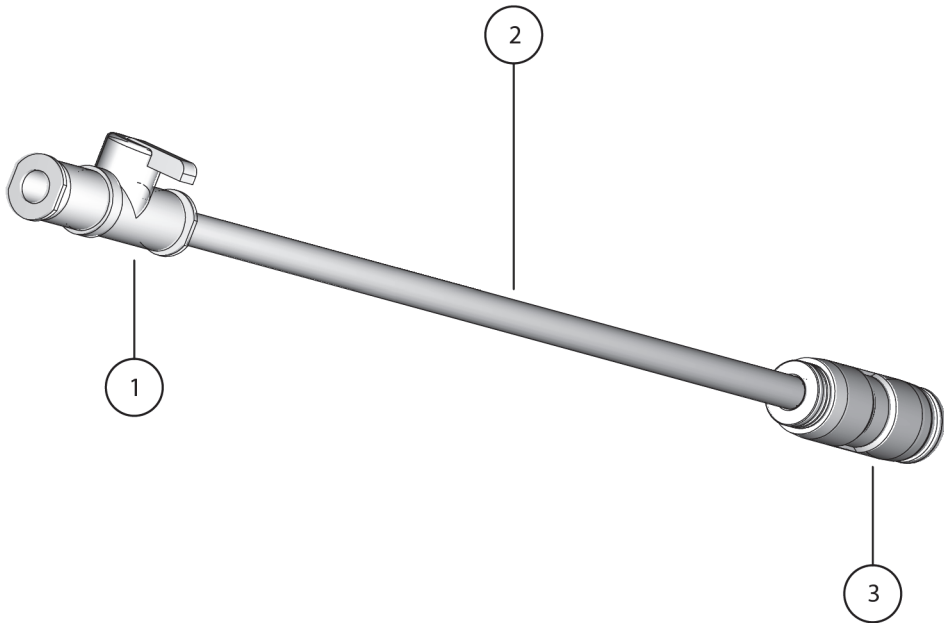
**Figure 7-5 Irrigation parts****Table 16 Irrigation parts**

Item	Qty	Part number	Description
1	1	Q8302277	FITTING 1/4NPT M-M
2	-	U8902320	OD-6MM ID-3.4MM BLUE TUBE (SOLD PER FOOT)
3	1	U8902319	PUSH-IN TYPE REDUCER TO CONNECT OD-8MM TUBE WITH OD-6MM TUBE

## 7.2 Spare Part Kits

**Table 17 Spare parts kits**

Item	Qty	Part number	Description
1	-	Q8302280	KIT SPARE PART BASIC HYDROFORM 2
2	-	Q8302276	KIT SPARE PART WATER BOX HYDROFORM 2
3	-	Q8302278	KIT SPARE PART CARRIAGE HYDROFORM 2
4	-	Q8302279	KIT SPARE PART, INDEX ENCODER HYDROFORM 2
5	-	Q8302281	KIT SPARE PART MANUAL FULL HYDROFORM 2
6	-	Q8302282	KIT SPARE PART HARDWARE HYDROFORM 2

**Table 18 Kit spare part basic HydroFORM 2**

Item	Qty	Part number	Description
1	1	Q8302276	KIT SPARE PARTS WATER BOX HYDROFORM2
2	1	Q8302278	KIT SPARE PARTS CARRIAGE T HYDROFORM2
3	1	Q8302279	KIT SPARE PARTS INDEX ENCODER HYDROFORM2



Figure 7-6 Kit spare part, water box

Table 19 Kit spare part, water box HydroFORM 2

Item	Qty	Part number	Description
1	28	Q8300883	GASKET FOAM 1/4 in
	-	U8775184	GASKET FOAM 1/4 INCH KIT OF 100
2	5	Q8302275	PROTECTOR GASKET
3	2	Q8302273	DELAY LINE 14MM
4	4	Q8301772	SCREW SOCKET HEAD SS M3 × 0.5 MM, 8 MM
5	1	Q8302283	GASKET PROBE I8
6	2	Q8302272	GASKET WATERBOX

**Table 19 Kit spare part, water box HydroFORM 2 (continued)**

Item	Qty	Part number	Description
7	1	U8908626	VALVE QH-QS-6
8	1	U8902678	FITTING T-1/8 10-32 BARB BRAS
9	1	U8902319	QS-8-6 PUSH-IN REDUCING
10	1	Q8301182	SCRAPER, G10
11	1	Q8302284	KEYS HEX LONG ARM BALL 1.5 A 10MM 9PCS

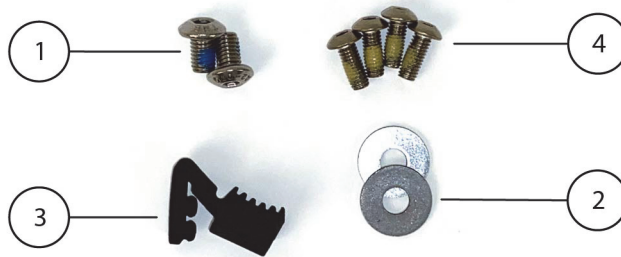
**Figure 7-7 Kit spare part, carriage****Table 20 Kit spare part, carriage HydroFORM 2**

Item	Qty	Part number	Description
1	2	Q8302255	SCREW BUTTON SOCKET HEAD THR-LOCK M5 × 8MM
2	2	Q8302256	FLAT WASHER M5 OD-15MM STAIN
3	1	Q8302254	HYDROFORM 2 LINING BRAKE
4	4	Q8302238	SCREW BUTTON HEX M4 × 0.70MM 18-8 SST 10MM

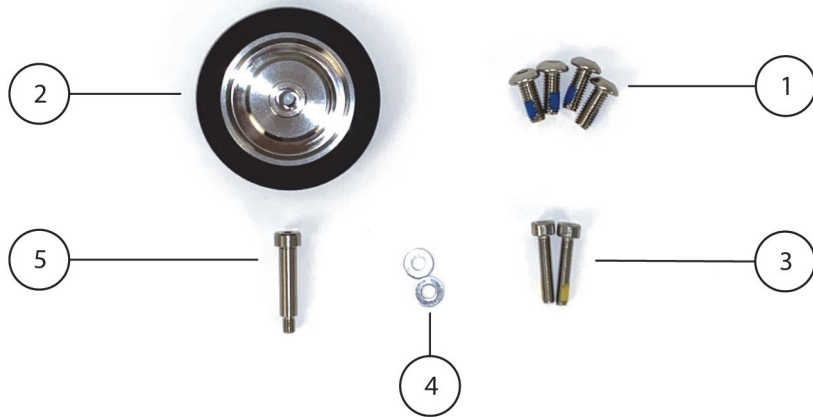

**Figure 7-8 Kit spare part, index encoder**

**Table 21 Kit spare part, index encoder HydroFORM 2**

Item	Qty	Part number	Description
1	4	Q8302238	SCREW BUTTON HEX M4 × 0.70MM 18-8 SST 10MM
2	1	Q8302285	WHEEL INDEX ENCODER
3	2	Q8302286	SCREW SST M3 × 16 HEX NYLON PATCH
4	2	Q8301745	FLAT WASHER M3 × 0.5MM STAIN
5	1	Q8301731	SHOULDER SCREW M3-0.5 4 × 16MM HEX

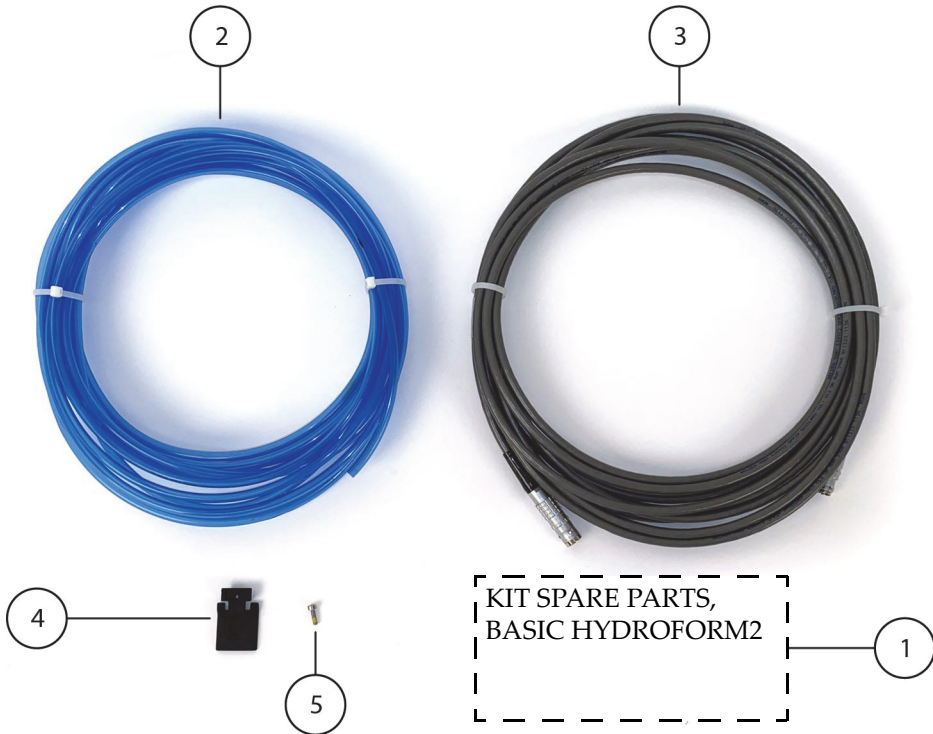

**Figure 7-9 Kit spare part, full**

**Table 22 Kit spare part, full HydroFORM 2**

Item	Qty	Part number	Description
1	1	Q8302280	KIT SPARE PARTS BASIC HYDROFORM2
2	25	U8902320	OD-6MM ID-3.4MM BLUE TUBE (SOLD PER FOOT)
3	1	Q8302244	CABL LEMO M-M 1K.316 TO 1T.310 2ENC 7.5M
4	1	Q8302287	PAD TIGHTENING
5	1	Q8302250	SCREW SOCKET HEAD SS M3 × 0.5 MM, 10 MM



**Table 23 Kit spare part hardware HydroFORM 2**

Item	Qty	Part number	Description
1	1	Q8302250	SCREW SOCKET HEAD SS M3 × 0.5 MM, 10 MM
2	4	Q8302288	INSERT HEAT-SET FOR PLASTICS M3
3	1	Q8302261	SCREW M4 SHOULDER 5 × 4MM
4	4	Q8302238	SCREW BUTTON HEX M4X0.70MM 18-8 SST 10MM
5	4	Q8302255	SCREW BUTTON SOCKET HEAD THR-LOCK M5X8MM
6	4	Q8302256	FLAT WASHER M5 OD-15MM STAIN
7	1	U8779489	NUT M3 STAIN LOCK NYLON
8	1	Q8301772	SCREW SOCKET HEAD SS M3 × 0.5 MM, 8 MM
9	4	U8906398	SCREW M3X8MM PHI FLAT STAIN

## 7.3 HydroFORM Holders

This section provides information on the accessories required to mount the HydroFORM scanner onto other scanners.

If the correct HydroFORM package has been purchased, you should not need to order separately any accessories in this section.

### 7.3.1 Fork Kit

This fork kit is made to attach the HydroFORM scanner on ChainSCANNER, MapROVER and SteerROVER probe holders (see Figure 7-10 on page 110).

P/N: Q7750241

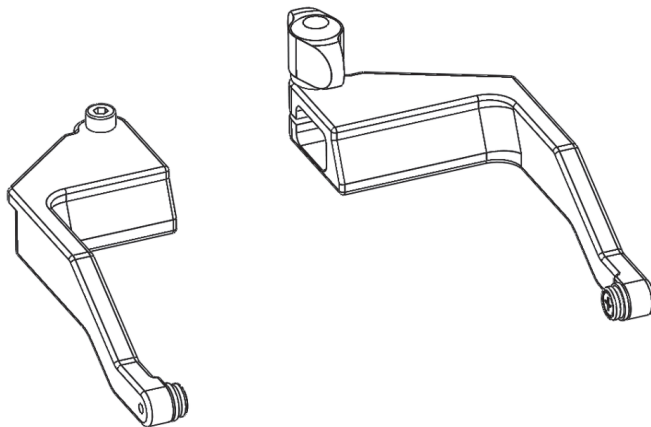
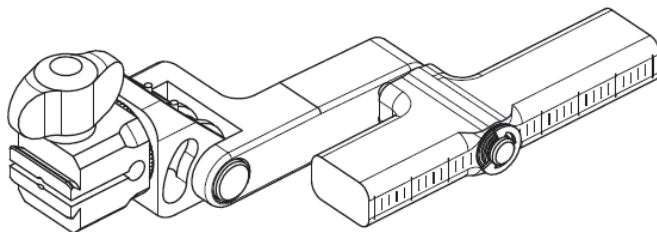

**Figure 7-10 HydroFORM fork kit**

### **7.3.2 ChainSCANNER Pivoting Probe Holder**

The ChainSCANNER pivoting probe holder is included in the HydroFORM2-K-ADPCHAIN scanner package (see Figure 7-11 on page 110 and Figure 7-12 on page 111).

P/N: Q8301401



**Figure 7-11 Pivoting probe holder**

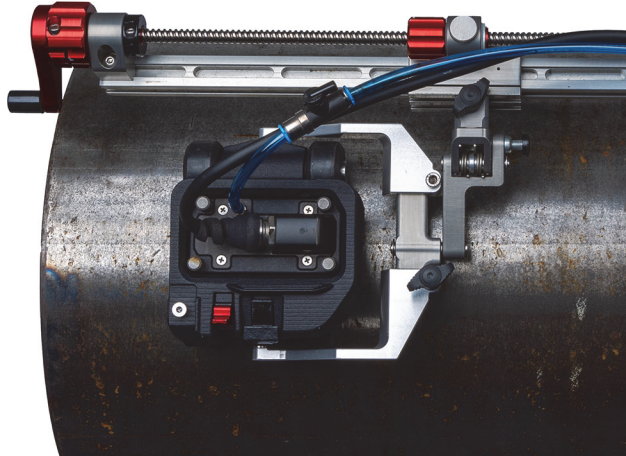
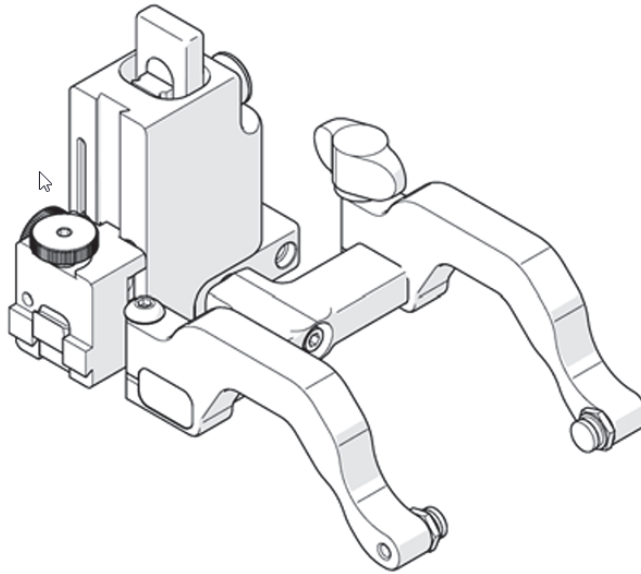

**Figure 7-12 HydroFORM mounted on a ChainSCANNER with pivoting probe holder and fork kit**

### **7.3.3 Heavy Duty Probe Holder**

The heavy duty vertical probe holder is included in the MapSCANNER scanner package (see Figure 7-13 on page 112).

P/N: Q7750122

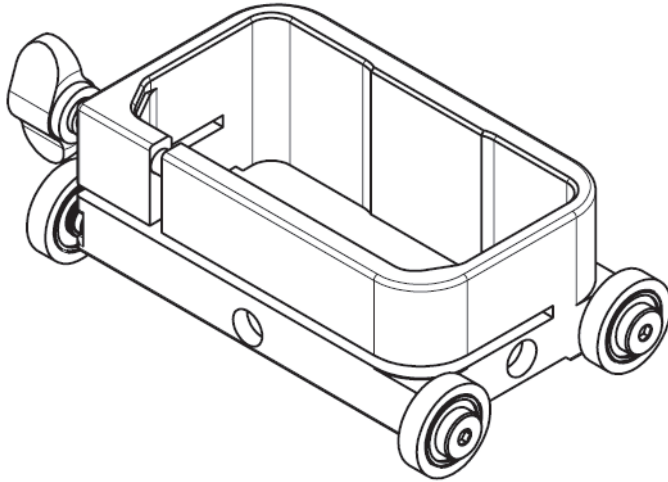

**Figure 7-13 Heavy duty vertical probe holder**

### **7.3.4 MapSCANNER Carriage**

The MapSCANNER Carriage is required to mount the HydroFORM scanner onto the MapSCANNER and is included in the HydroFORM2-K-SAUT scanner package (see Figure 7-14 on page 113 and Figure 7-15 on page 113).

P/N: Q7750240



**Figure 7-14 MapSCANNER carriage**

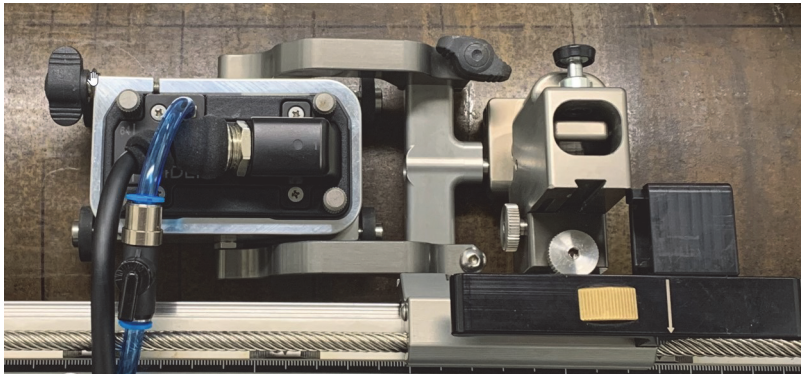

**Figure 7-15 The HydroFORM mounted on the MapSCANNER with the heavy duty vertical probe holder and MapSCANNER carriage**

### **7.3.5 MapROVER/SteerROVER Probe Holder**

This wide yoke version of the heavy duty vertical probe holder is included with MapROVER and SteerROVER scanner packages (see Figure 7-16 on page 114 and Figure 7-17 on page 115).

Mounting the HydroFORM scanner on a MapROVER or SteerROVER also requires the use of the fork kit (see “Fork Kit” on page 109).

The fork kit is also included in HydroFORM2-K-AUT package (see Table 6 on page 46).

P/N: Q7750123

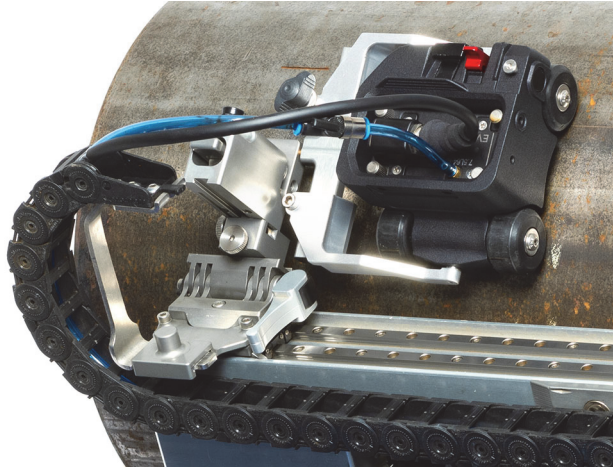

**Figure 7-16 HydroFORM scanner mounted on a MapROVER using the heavy duty vertical probe holder and fork kit**

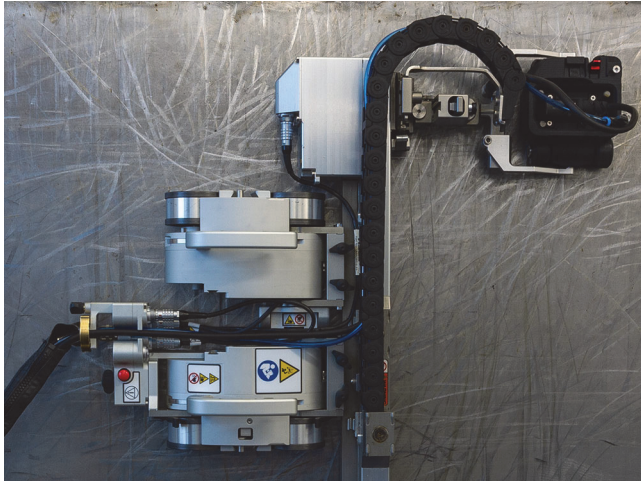

**Figure 7-17 HydroFORM scanner mounted on a SteerROVER using the heavy duty vertical probe holder and fork kit**





# Appendix A: ScanDeck Commands

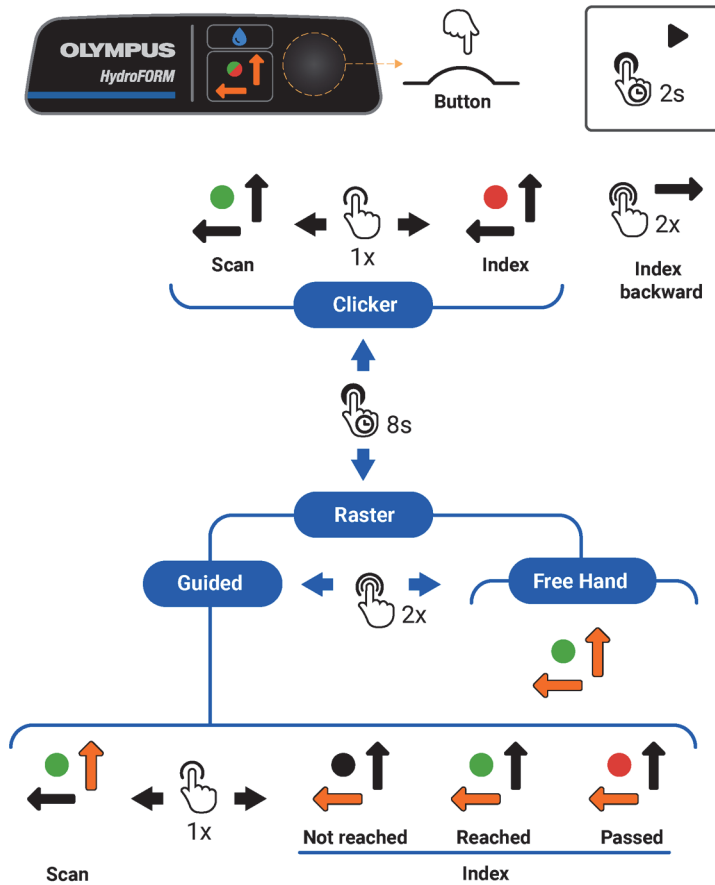

Figure 7-18 ScanDeck commands quick reference

---

**NOTE**

To prevent synchronization issues, do not click on the ScanDeck button while the OmniScan is on pause.

Also, do not use the Play button directly on the OmniScan while in indexing mode on the ScanDeck. It is recommended to always make a long press on the ScanDeck button to start the acquisition.

To solve synchronization issues, unplug and replug the encoder cable from the instrument.

---

---

## List of Figures

---

Figure 1-1	HydroFORM Scanner with ScanDeck module and index encoder .....	23
Figure 1-2	HydroFORM case contents .....	24
Figure 1-3	HydroFORM scanner components .....	25
Figure 1-4	Carriage .....	26
Figure 1-5	Carriage ridges .....	27
Figure 1-6	Probe array first and sixty-fourth elements .....	27
Figure 1-7	Brake lever (engaged) .....	29
Figure 1-8	ScanDeck module .....	30
Figure 1-9	ScanDeck control pad .....	31
Figure 1-10	Encoder locations .....	33
Figure 1-11	Encoder stowed and released .....	34
Figure 1-12	Encoder friction ring .....	35
Figure 1-13	Phased array probe .....	35
Figure 1-14	Probe holder .....	36
Figure 1-15	Umbilical and carriage connexions .....	38
Figure 1-16	Hooking the umbilical to the scanner .....	39
Figure 2-1	ChainSCANNER system .....	44
Figure 2-2	MapSCANNER-Mag system .....	45
Figure 2-3	MapROVER scanner .....	45
Figure 2-4	SteerROVER scanner .....	46
Figure 2-5	Index encoder removal .....	49
Figure 2-6	Disconnect encoder cable .....	49
Figure 2-7	Index encoder cable routing .....	50
Figure 2-8	ScanDeck removal .....	51
Figure 2-9	Carriage wheels .....	51
Figure 3-1	Delay line plate .....	54
Figure 3-2	Encoder wheel resistance .....	55
Figure 3-3	Gasket protector removal .....	57
Figure 4-1	Scanning hand positions .....	60
Figure 4-2	Indexing hand positions .....	61

Figure 4-3	Water control quarter-turn valve and lock-release lever .....	62
Figure 4-4	An example S-scan display .....	63
Figure 4-5	Index encoder stowed .....	67
Figure 4-6	Index encoder release tab .....	67
Figure 4-7	Index encoder operation .....	68
Figure 5-1	Probe holder exploded view .....	73
Figure 5-2	New foam and delay line plate .....	74
Figure 5-3	Installing the delay line plate on the probe-holder .....	74
Figure 5-4	Delay line vents .....	76
Figure 5-5	Probe retaining screws .....	77
Figure 5-6	Probe and gasket .....	78
Figure 5-7	Wheel removal .....	79
Figure 5-8	Brake pad removal .....	79
Figure 5-9	Brake shaft key slot .....	80
Figure 5-10	Brake shaft removal .....	81
Figure 5-11	Probe holder lock-release pad retaining screw .....	82
Figure 5-12	Probe holder lock-release pad removal .....	82
Figure 5-13	Index encoder assembly shoulder screw .....	83
Figure 5-14	Spring placement .....	84
Figure 5-15	Index encoder wheel screw .....	85
Figure 5-16	Wheel and shaft flats .....	86
Figure 5-17	Friction ring and step ring .....	86
Figure 6-1	Cable pinout and connector reference .....	91
Figure 6-2	HydroFORM front view dimensions .....	92
Figure 6-3	HydroFORM left side view dimensions .....	92
Figure 6-4	HydroFORM top view dimensions with index encoder .....	93
Figure 6-5	HydroFORM top view dimensions, no index encoder .....	94
Figure 6-6	HydroFORM front view dimensions, no index encoder, no ScanDeck .....	94
Figure 7-1	HydroFORM General exploded view .....	96
Figure 7-2	Carriage exploded view .....	98
Figure 7-3	Index Encoder exploded view .....	100
Figure 7-4	Probe Holder exploded view .....	102
Figure 7-5	Irrigation parts .....	103
Figure 7-6	Kit spare part, water box .....	105
Figure 7-7	Kit spare part, carriage .....	106
Figure 7-8	Kit spare part, index encoder .....	107
Figure 7-9	Kit spare part, full .....	108
Figure 7-10	HydroFORM fork kit .....	110
Figure 7-11	Pivoting probe holder .....	110
Figure 7-12	HydroFORM mounted on a ChainSCANNER with pivoting probe holder and fork kit .....	111
Figure 7-13	Heavy duty vertical probe holder .....	112

Figure 7-14 MapSCANNER carriage ..... 113

Figure 7-15 The HydroFORM mounted on the MapSCANNER with the heavy duty  
vertical probe holder and MapSCANNER carriage ..... 113

Figure 7-16 HydroFORM scanner mounted on a MapROVER using the heavy duty  
vertical probe holder and fork kit ..... 114

Figure 7-17 HydroFORM scanner mounted on a SteerROVER using the heavy duty  
vertical probe holder and fork kit ..... 115

Figure 7-18 ScanDeck commands quick reference ..... 117



---

## List of Tables

---

Table 1	Compatible scanners .....	22
Table 2	ScanDeck status LED behavior .....	31
Table 3	Couplant check LED behavior .....	32
Table 4	ScanDeck button .....	32
Table 5	Compatible auxiliary scanners .....	44
Table 6	Scanner configurations .....	46
Table 7	Modifications for semiautomated auxiliary scanners .....	47
Table 8	Modifications for automated auxiliary scanners .....	48
Table 9	Delay line thickness range .....	53
Table 10	Specifications .....	89
Table 11	Digital signal assignment .....	91
Table 12	General parts list .....	96
Table 13	Carriage .....	98
Table 14	Index encoder .....	100
Table 15	Probe holder .....	102
Table 16	Irrigation parts .....	103
Table 17	Spare parts kits .....	104
Table 18	Kit spare part basic HydroFORM 2 .....	104
Table 19	Kit spare part, water box HydroFORM 2 .....	105
Table 20	Kit spare part, carriage HydroFORM 2 .....	106
Table 21	Kit spare part, index encoder HydroFORM 2 .....	107
Table 22	Kit spare part, full HydroFORM 2 .....	108
Table 23	Kit spare part hardware HydroFORM 2 .....	109

