Operation Manual

AL120-12 Series

300mm Semiconductor Wafer Loader

Wafer Loader

AL120-LMB12-LP3

AL120-LMB12-F

Wafer Loader Accessory

AL120-VS12

AL120-RC

Thank you for purchasing the EVIDENT AL120 Series Wafer Loader.
In order to fully utilize its performance and secure safety, please read this manual before operation.
Please also keep it at hand during operation as well as for future reference.

AM5059-03

i Introduction

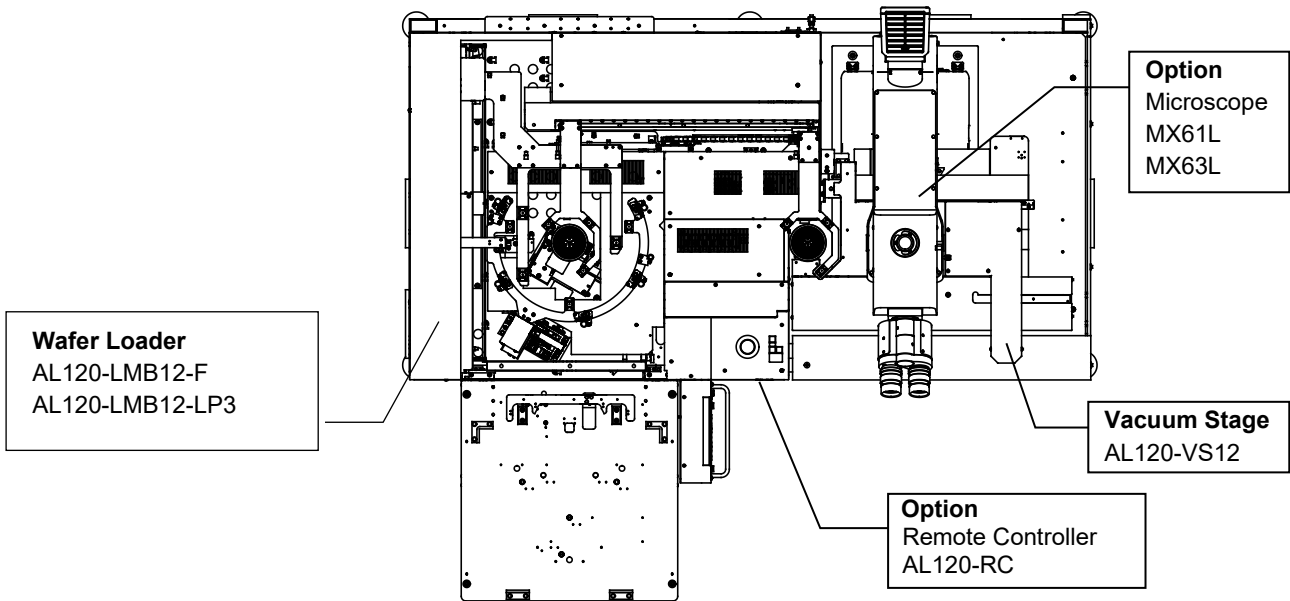

AL120 Series Lineup

This product is an auto loader to transfer the wafer from the cassette to the microscope. The macro observation is available while transferring wafers.

AL120 series products consist of a model name and an applicable wafer size.

Note that only the AL120 series products with the same wafer size can be combined.

(The remote controller is common to all the AL120 series products.)

AL120 series

Series name	Model name	Wafer size	Cassette type
AL120-	LMB	12	-LP3

LMB: Type of Wafer Loader

-F : FOSS specification
-LP3 : FOUP opener specification

Stage

Series name	Model name	Wafer size
AL120-	VS	12

The AL120 series consists of a wafer loader, a vacuum stage, and other products.

This manual does not cover custom-order specifications or microscopes.

To acquire a comprehensive understanding of both your loader and microscope, please refer to your microscope operation manual.

Please prepare the cassettes and wafers at your side.

1. Precautions

Operators must follow the instructions in the Operation/Maintenance Manual. If these instructions are not followed, safety can not be assured, and malfunctions may occur.

The following 3 types of symbols are used in this Manual to draw operators' attention.



CAUTION

: Indicates a potentially hazardous situation which, if not avoided, may result in minor or moderate injury.

NOTICE

: Indicates a potentially hazardous situation which, if not avoided, may result in damage to the product or other property and/or may cause problems.

2. Safety Precautions



CAUTION

1. Always use the power cord provided by EVIDENT. If no power cord is provided , please select the power cord by referring to the section “PROPER SELECTION OF THE POWER SUPPLY CORD” at the end of this chapter. If the proper power cord is not used, EVIDENT can no longer warrant the electrical safety performance of the equipment. Layout the power cord at a sufficient distance from the sources of heat such as the power supply unit/light source and lamp housing to avoid contact with these heat sources.
2. Use the device within the scope of the specifications.
3. When you move equipment, notify EVIDENT distributor.
4. Always Install the product at the location where you can reach the power cord at hand to disconnect it quickly. In case the abnormality is found with the loader, pull out the power cord immediately from the back side of the loader.
5. Bundle cables or tubes to the table legs, etc. to prevent your legs from getting caught in cables or tubes.
6. Be sure to connect the ground terminal of the power cord and that of the power outlet. Otherwise, the electric safety performance intended by EVIDENT cannot be assured.
7. Never place a metallic object in the ventilation. This could cause an electrical shock or malfunction.
8. Maintenance works must be done by well-trained person.
9. When it cleans a broken wafers, it is use with protection gloves etc.
10. In case the vacuum supply is stopped, a risk of dropping the wafer may be caused during the test. It is recommended to connect the check valve or the buffer tank in order to maintain the vacuum in case the vacuum supply is stopped. The check valve

or the buffer tank is not provided with this product. If you need them, contact EVIDENT.

11. Be careful, if you transfer the wafer in the down-flow status that may allow the wafer to sway, the risk may be caused in transferring the wafer.
12. Be sure to use the cassette complied with SEMI standards. Using the distorted cassette may cause the risk of damaging the wafer, etc.
13. To allow each microscope manifest its full performance, reserve an installation space having the minimum dimensions described below before assembly and installation of the microscope.

*The dimensions of the area enclosed in alternate long and two short dashes lines indicate the stage movement range.*When maintenance is required, a larger work space can be prepared by changing the observation tube orientation or moving the stage.

*The following installation space is set according to the SEMI standard guidelines (SEMI S8-1016).It is recommended that you set the optimum installation space for each customer by referring to the following installation space data as well as the appearance of the system, eye point height, etc.

14. FOUP opener is equipped with a power shut-off switch, located near the top edge of the open door.

This switch is mechanically coupled with the window opening/closing system.

The switch is exposed on the upper position of the door while the window is open ,and stored in a position where it does not touch the door while the window is closed. If the door of the FOUP opener closes while the window is open, the switch is turned off and the power of the FOUP opener is shut off.This system prevents injuries from getting hands caught in the door.



AL120-LMB12-F installation space

Unit:mm

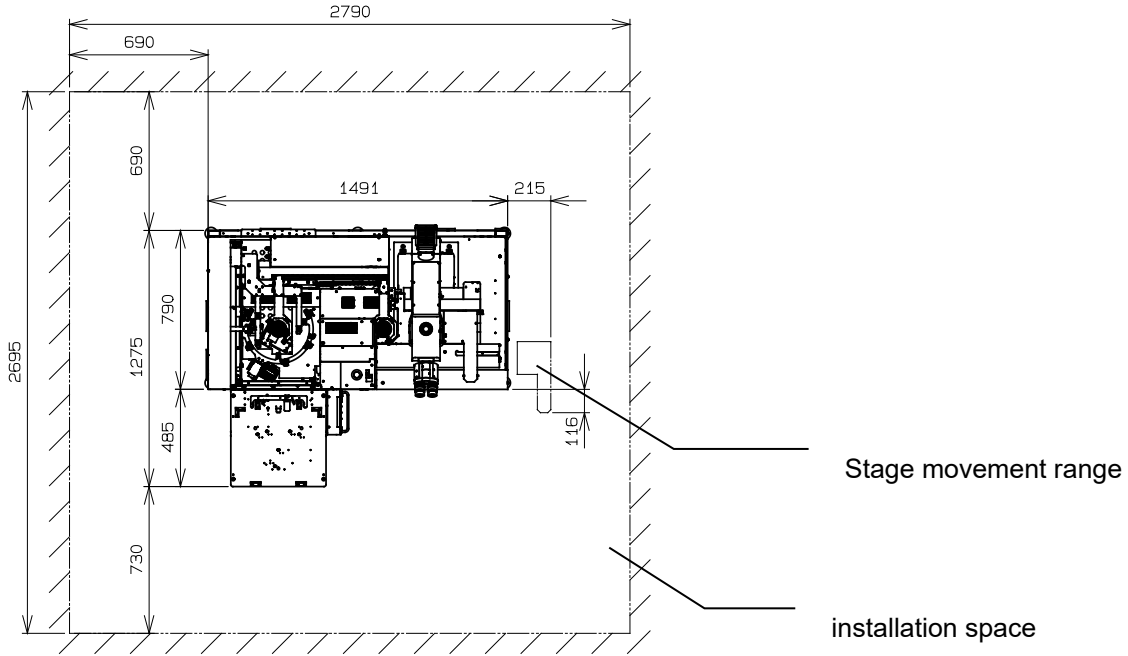

AL120-LMB12-F external view,eye point and center of gravity

Unit:mm

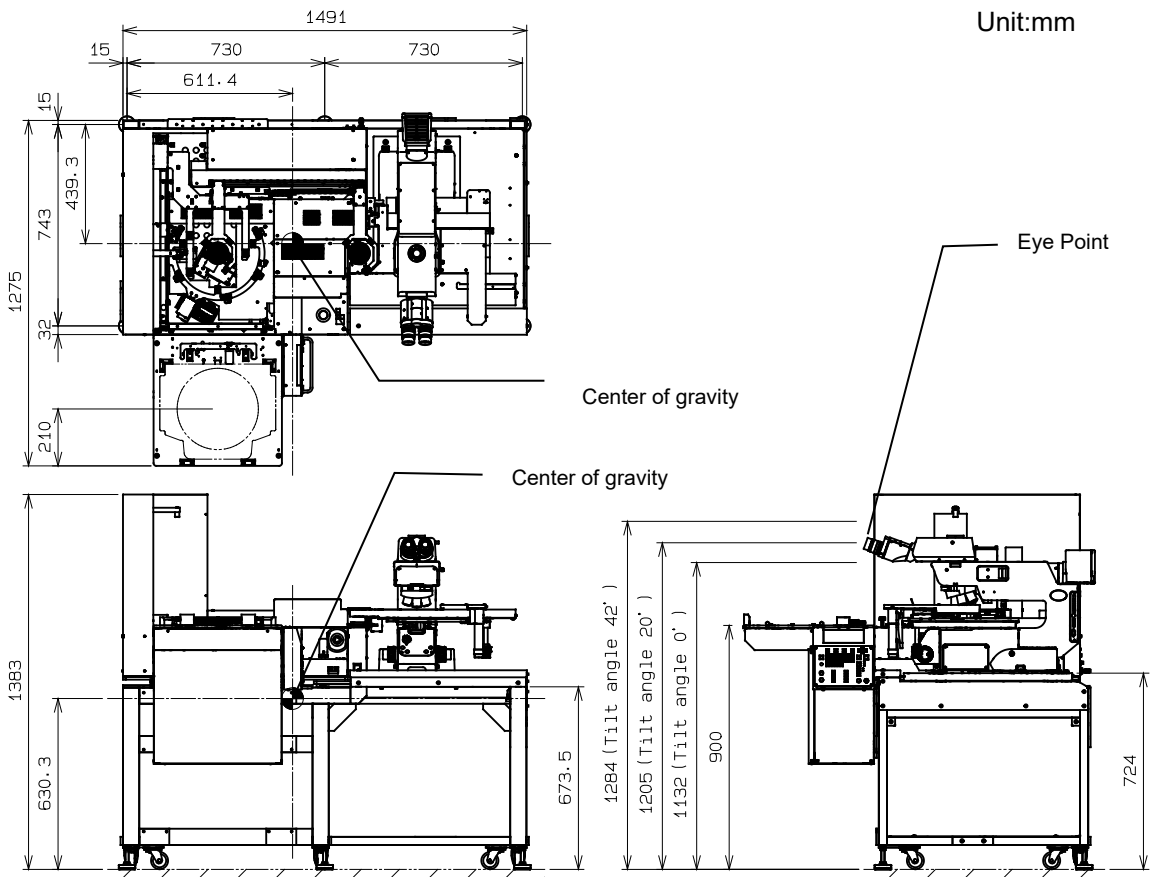

AL120-LMB12-LP3 installation space

Unit:mm

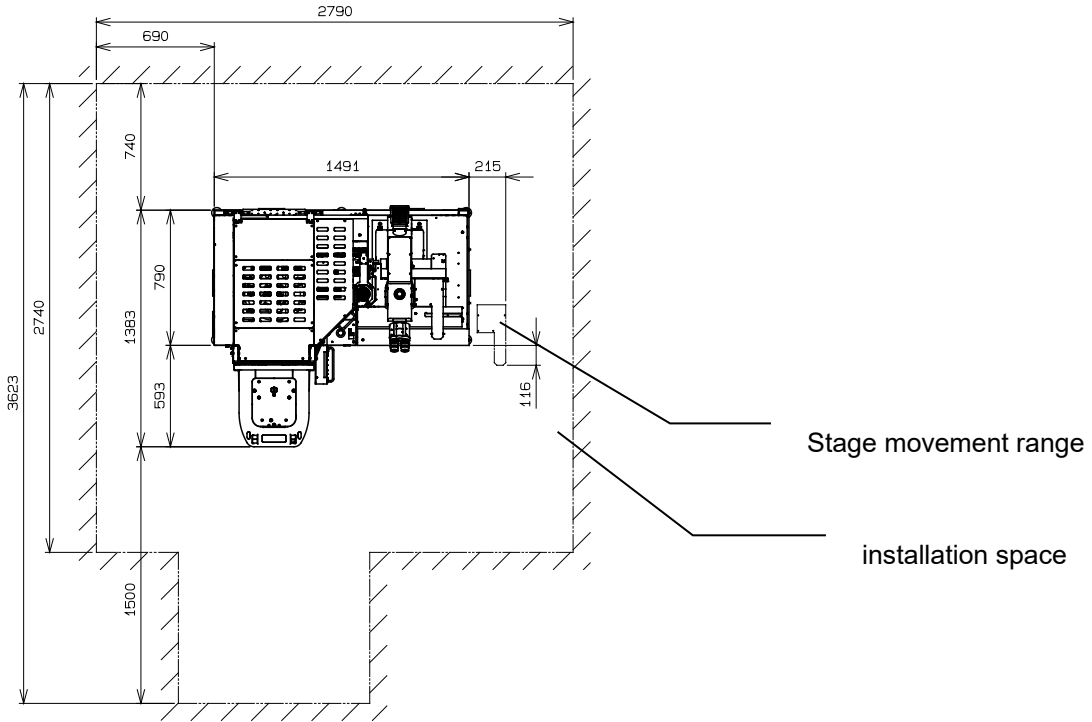

AL120-LMB12-LP3 external view,eye point and center of gravity

Unit:mm

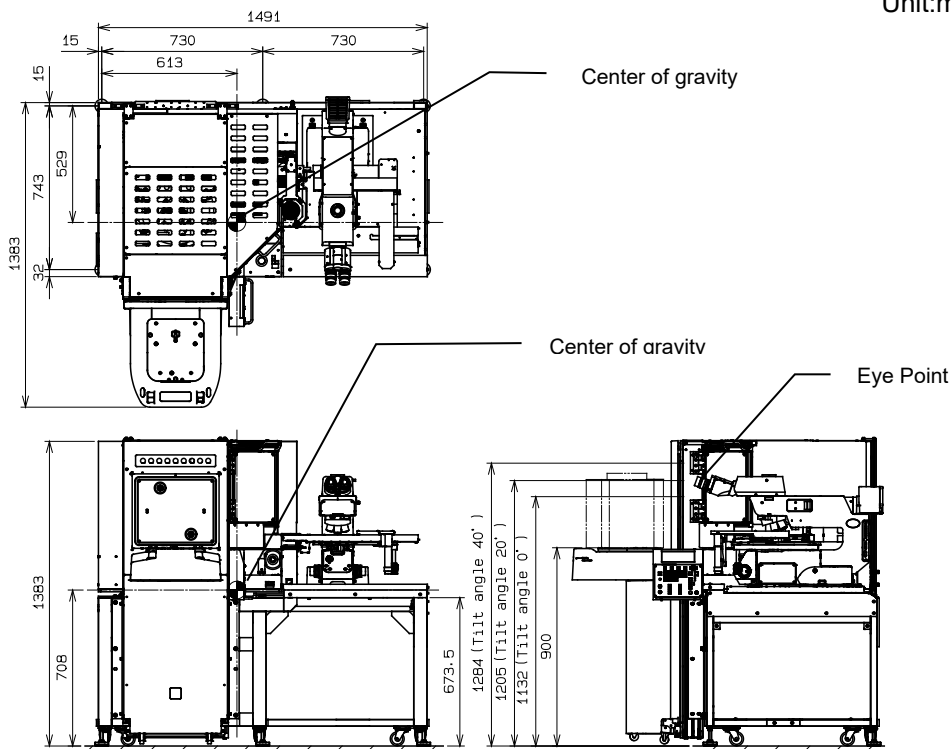



Earthquake Protection

Please fix the equipment to the supporting floor so as not to be moved by unexpected force such as an earthquake using stoppers or equivalent means as per the requirements.

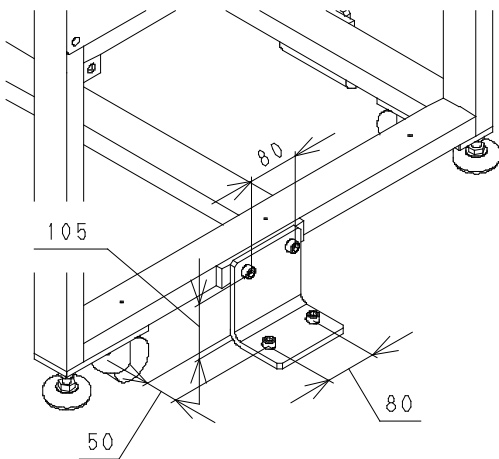
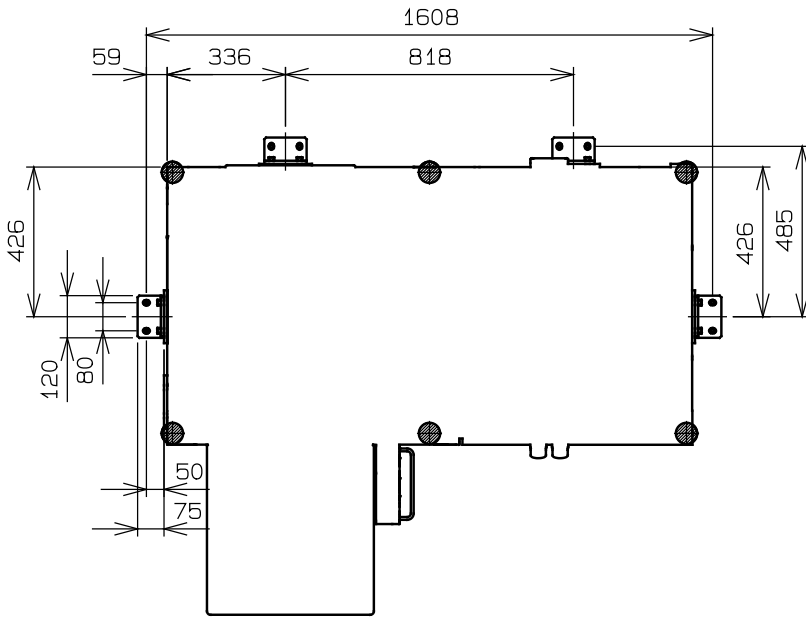

Quakeproof fixed parts (Option)

Material: Stainless Steel



Plate Thickness: 9mm

Fixing bolts: M10



Safety Symbols



The following symbols are affixed to the device. In order to safely operate this device, be sure to familiarize yourself with the meanings of individual symbols.

	This symbols indicate the presence of mechanical parts that can result in pinching, crushing or other bodily injury.
	Indicates that the main switch is ON.
	Indicates that the main switch is OFF.

Warning Indications

Warning indications are attached on the part which the special attention should be paid to the safety when operating/using the equipment.

Follow the instructions surely.

 <p>CAUTION</p> <p>MECHANICAL HAZARD Contact with moving parts causes injury by getting caught or pinched. Keep hands and garments away from moving parts. Consult manual for servicing instructions.</p>	
---	--

Warning indications position:

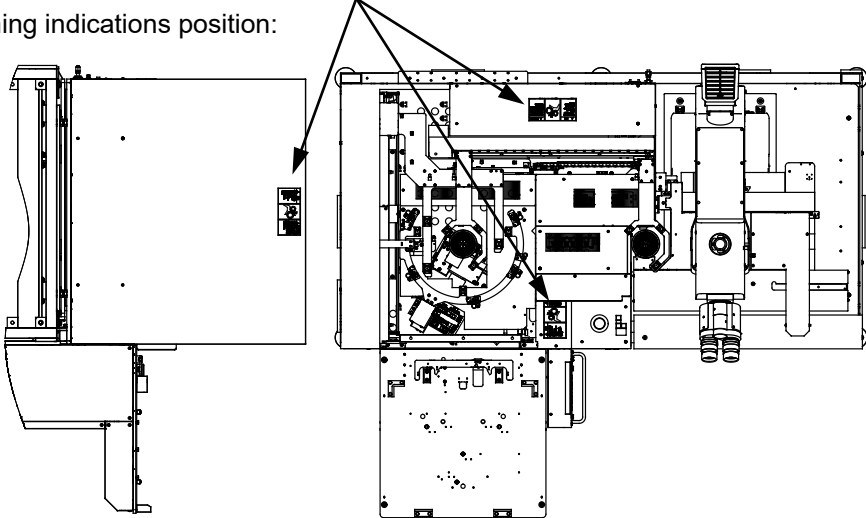

Each arm of this device is electric drive.
 The whole device movement is attention not to put a hand and a face in a device.

If these symbols become dirty or peel off, contact your nearest EVIDENT distributor for exchange and servicing.

3. Before Starting Operations

In order to get the best performance from the loader, as well as to ensure safety, please follow the 3 points listed below.



1. Never put your hands in the loader.
2. Do not deliberately place wafers or other objects in or remove from the loader while it is in operation.
If excess force is applied to the wafer under inspection, it could lose its adhesiveness and could be damaged.
3. Make sure that the main switch is turned off before removing a wafer for unavoidable reasons such as malfunctions.

4. Maintenance and Storage

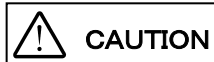

Be sure to set the main switch to O(OFF) and disconnect the power cord from the back side of the loader before starting following operations.

1. Wipe each part of the loader using a soft cloth moistened with pure water.
Wipe heavy dirt or stains with a clean paper moistened with commercially available absolute alcohol.
Never place absolute alcohol close to a flame as it is highly flammable.
Take care not to cause sparks by turning on or off an electric appliance or fluorescent lamp.
2. Wear gloves to protect your hands while cleaning the loader when for example a wafer is damaged.
3. Periodically check the loader for wear (a wafer loading arm and deterioration of the drive mechanism), and replace the parts as needed. Contact your nearest EVIDENT distributor for repair.

NOTICE

1. Never disassemble the loader unnecessarily. This could affect the performance and function of the loader.
2. Contact your nearest EVIDENT distributor if you need MSDS.
3. Confirm and observe your local municipal ordinances or regulations when you dispose of the loader.
If you have any questions, contact your nearest EVIDENT distributor.
4. Lenses and solders used by this system are lead-free.

5. Daily Check

1. Confirm the following points before operating the loader.

- (1) Vacuum supply pressure: -67KPa to -80KPa

When there are not a vacuum gauge and a regulator, please contact it to the EVIDENT distributor.

- (2) Clean dry air supply pressure : 0.5MPa to 0.6MPa. [AL120-LMB12-LP3]
- (3) Make sure that there are no wafers or tools inside the wafer loader

2. Confirm the following points before starting the inspection.

- (1) Make sure that the power is on (Check the liquid crystal panel)

Turn the main switch ON and make sure that each arm position is initialized and the model name is shown on the liquid crystal panel.

The loader may have been set to skip initialization when the power is turned on. This is not a malfunction. The loader executes initialization when the [Start] button is pressed.

AL120-LMB12-LP3	ALL
Press Start button	
No	Size Thick Comment
1.	300 775-500
Recall	Wafer Setting Memory

- (2) Check the Emergency Off Switch

When the Emergency Off Switch is pressed, make sure that the power supply shuts down and the main switch turns OFF.

- (3) Confirmation of automatic power supply interception of FOUP opener

Open the observation window, and select [Test Program] -> [Test No.1] -> <Menu2>[M2], and then start <Z axis movement check> by pressing the start switch.

Make sure that the door of the FOUP opener rises and the power of the FOUP opener is shutoff by the interlock switch.

- (4) Please make sure to close the observation window for macroinspection before turn on the power.



Please never put the hand in the FOUP door while this device is working

6. Conformity Standards

- (1) This equipment is carrying out conformity or evaluation to the following standard.
- (2) Although this equipment aims at using in the industrial environment, since it may not satisfy a performance when not used by the right operation method, please carry out the proper handling according to this manual.

**CAUTION**

This equipment is an object for industrial environment (Class A). Other equipment may be affected if it is used in a housing environment.

FCC

This product has been tested and found to comply with the limits for a Class A digital device, pursuant to Part 15 of the FCC rules. These limits are designed to provide reasonable protection against harmful interference when the product is operated in a commercial environment. This product generates, use, and can radiate radio frequency energy and, if not installed and used in accordance with the instruction manual, may cause harmful interference to radio communications.

Operation of this product in a residential area is likely to cause harmful interference in which case the user will be required to correct the interference at his own expense.

**CAUTION**

FCC WARNING:

Changes or modifications not expressly approved by the party responsible for compliance could void the user's authority to operate the product.

FCC Supplier's Declaration of Conformity

Hereby declares that the product

Product name: Semiconductor Wafer Loader, Semiconductor Wafer Loader and Accessory

Model Number: AL120-LMB12-LP3

Conforms to the following specifications:

FCC Part 15, Subpart B, Section 15.107 and Section 15.109

Supplementary Information:

This device complies with part 15 of the FCC Rules. Operation is subject to the following two conditions: (1) This device may not cause harmful interference, and (2) this device must accept any interference received, including interference that may cause undesired operation.

Responsible Party Name: EVIDENT Scientific Solutions Americas Corp.

Address: 48 Woerd Ave Waltham, MA 02453, U.S.A.

Phone Number: 781-419-3900

SEMI

This equipment is carrying out evaluation to the guideline of the following SEMI standard.

- S2-1016: Safety Guidelines for Semiconductor Manufacturing Equipment
- S8-1016: Safety Guidelines for Ergonomics Engineering of Semiconductor Manufacturing Equipment

For Korea only

이 기기는 업무용 환경에서 사용할 목적으로 적합성평가를 받은 기기로서 가정용 환경에서 사용하는 경우 전파간섭의 우려가 있습니다.



■ PROPER SELECTION OF THE POWER SUPPLY CORD

If no power supply cord is provided, please select the proper power supply cord for the equipment by referring to "Specifications" and "Certified Cord" below:

CAUTION: In case you use a non-approved power supply cord for Olympus products, Olympus can no longer warrant the electrical safety of the equipment.

Specifications

Voltage Rating	125V AC (for 100-120V AC area) or, 250V AC (for 220-240V AC area)
Current Rating	6A minimum
Temperature Rating	60°C minimum
Length	3.05 m maximum
Fittings Configuration	Grounding type attachment plug cap. Opposite terminates in molded-on IEC configuration appliance coupling.

Table 1 Certified Cord

A power supply cord should be certified by one of the agencies listed in Table 1, or comprised of cordage marked with an agency marking per Table 1 or marked per Table 2. The fittings are to be marked with at least one of agencies listed in Table 1. In case you are unable to buy locally in your country the power supply cord which is approved by one of the agencies mentioned in Table 1, please use replacements approved by any other equivalent and authorized agencies in your country.

Country	Agency	Certification mark	Country	Agency	Certification mark
Argentina	IRAM		Italy	IMQ	
Australia	SAA		Japan	JET	
Austria	ÖVE		Netherlands	KEMA	
Belgium	CEBEC		Norway	NEMKO	
Canada	CSA		Spain	AEE	
Denmark	DEMKO		Sweden	SEMKO	
Finland	FEI		Switzerland	SEV	
France	UTE		United Kingdom	ASTA BSI	
Germany	VDE		USA	UL	
Ireland	NSAI				

Table 2 HAR flexible cord

Approval organizations and cordage harmonization marking methods

Approval organization	Printed or embossed harmonization marking (May be located on jacket or insulation of internal wiring)		Alternative marking utilizing black-red-yellow thread (Length of color section in mm)		
			Black	Red	Yellow
Comite Electrotechnique Belge (CEBEC)	CEBEC	⌀HAR⌀	10	30	10
Verband Deutscher Elektrotechniker (VDE) e.V. Prüfstelle	⌀VDE⌀	⌀HAR⌀	30	10	10
Union Technique de l'Electricite' (UTE)	USE	⌀HAR⌀	30	10	30
Instituto Italiano del Marchio di Qualita' (IMQ)	IEMMEQU	⌀HAR⌀	10	30	50
British Approvals Service for Electric Cables (BASEC)	BASEC	⌀HAR⌀	10	10	30
N.V. KEMA	KEMA-KEUR	⌀HAR⌀	10	30	30
SEMKO AB Svenska Elektriska Materielkontrollanstalter	SEMKO	⌀HAR⌀	10	10	50
Österreichischer Verband für Elektrotechnik (ÖVE)	⌀ÖVE⌀	⌀HAR⌀	30	10	50
Danmarks Elektriske Materialkontroll (DEMKO)	⌀DEMKO⌀	⌀HAR⌀	30	10	30
National Standards Authority of Ireland (NSAI)	⌀NSAI⌀	⌀HAR⌀	30	30	50
Norges Elektriske Materiekkontroll (NEMKO)	NEMKO	⌀HAR⌀	10	10	70
Asociacion Electrotecnica Y Electronica Espanola (AEE)	⌀UNED⌀	⌀HAR⌀	30	10	70
Hellenic Organization for Standardization (ELOT)	ELOT	⌀HAR⌀	30	30	70
Instituto Portages da Qualidade (IPQ)	np	⌀HAR⌀	10	10	90
Schweizerischer Elektro Technischer Verein (SEV)	SEV	⌀HAR⌀	10	30	90
Elektriska Inspektoratet	SETI	⌀HAR⌀	10	30	90

Underwriters Laboratories Inc. (UL)
Canadian Standards Association (CSA)

SV, SVT, SJ or SJT, 3 X 18AWG
SV, SVT, SJ or SJT, 3 X 18AWG

Table of Contents

1 Nomenclature	1-1
1-1 Wafer Loader Main Body	1-1
1-1-1 AL120-LMB12-F	1-1
1-1-2 AL120-LMB12-LP3	1-2
1-1-3 BACK PART [MAIN DISCONNECTOR][AL120-LMB12-F]	1-3
1-1-4 BACK PART [MAIN DISCONNECTOR][AL120-LMB12-LP3]	1-3
1-1-5 OPERATION PANEL	1-4
1-1-6 FOUP OPENER OPERATION DISPLAY PANEL	1-4
1-2 Remote Controller (Option)	1-5
2 Outline of Operation Procedures	2-1
1 Description of Symbols	2-1
2 Operation Procedure	2-1
2-1 Procedure before Starting Transfer	2-3
Preparation	2-3
1 Turning the Main Switch ON: Main Switch	2-3
2 Cassette Setting	2-3
3 FOUP OPENER(AL120-LMB12-LP3)	2-4
4 Selecting the Type of Inspection Wafer: 4-way button	2-5
5 Setting the Sequence (Inspection Type: [Observation] Button)	2-6
6 Setting the Inspection Mode	2-7
7 Selecting Wafers for Inspection: Wafer No. Selector Button	2-9
8 Setting the Orientation Flat and Notch Positions on the Microscope: [Wafer alignment] Position Control	2-10
9 Setting the Inspection Time: [Inspection Time] Control	2-10
10 Detailed Settings for the Top Macro Inspection: [Top macro spin direction] and [Topmacro spin speed] Controls	2-10
11 Setting Wafer Alignment when Unloading a Wafer	2-11
2-2 Vacuum Stage	2-13
1 How to Move the Vacuum Stage	2-13
2 How to Use the Grip Handle	2-13
3 How to Use the Wafer Rotating Knob	2-13
2-3 Start of Transfer	2-14
1 Start of Transfer: [Start] Button	2-14

Table of Contents

2	Status of the Loader in Operation	2-14
3	Top Macro Inspection	2-15
4	Back Macro Inspection and 2nd Back Macro Inspection: Setting the Back Macro Tilt Angle	2-15
5	Observation window for macro inspection (AL120-LMB12-LP3)	2-16
6	Transferring a Wafer onto the Vacuum Stage	2-17
7	Temporarily Registering the Inspection Results: [Registration] Button	2-18
2-4	Stoppage of Transfer	2-19
1	Temporarily Stopping the Loader during Inspection: [Pause] Button	2-19
2	Removing a Wafer with Tweezers during Inspection: [Wafer Reject] Button	2-19
3	Unloading a Wafer during Inspection: [Unload] Button	2-20
4	EMO: [EMERGENCY OFF] Button	2-20
5	Terminating the Inspection: [Quit] Button	2-20

3 Inspections **3-1**

3-1	Preparations	3-1
3-2	Inspection Operations	3-1
3-2-1	MICROSCOPE INSPECTION	3-1
3-2-2	TOP MACRO INSPECTION	3-3
3-2-3	BACK MACRO INSPECTION	3-4
3-2-4	BACK MACRO INSPECTION + 2ND BACK MACRO INSPECTION	3-5
3-2-5	TOP MACRO INSPECTION + MICROSCOPE INSPECTION	3-6
3-2-6	BACK MACRO INSPECTION + MICROSCOPE INSPECTION	3-8
3-2-7	TOP MACRO INSPECTION + BACK MACRO INSPECTION	3-10
3-2-8	MICROSCOPE INSPECTION + TOP MACRO INSPECTION + BACK MACRO INSPECTION + 2ND BACK MACRO INSPECTION	3-11
3-3	Special Operations	3-13
3-3-1	CHANGING THE WAFER SELECTION SETTING	3-13

4 Specifications **4-1**

5 Problems during Use and Solutions **5-1**

5-1	When Warning Codes Are Displayed	5-1
5-2	When Error Codes Are Displayed	5-4
5-3	How to Reset the Circuit Breaker	5-12

Table of Contents

5-4 Emergency Off	5-12
5-5 Power Failure	5-12
5-6 Automatic Unloading	5-13
1 During the Top Macro Inspection	5-14
2 During the Back Macro Inspection	5-14
3 When a Wafer is on the F-arm	5-15
4 When a Wafer is on the A-arm	5-15
5 When a Wafer is on the Vacuum Stage	5-16

Table of Contents

This page intentionally left blank.

1 Nomenclature

1-1 Wafer Loader Main Body

1-1-1 AL120-LMB12-F

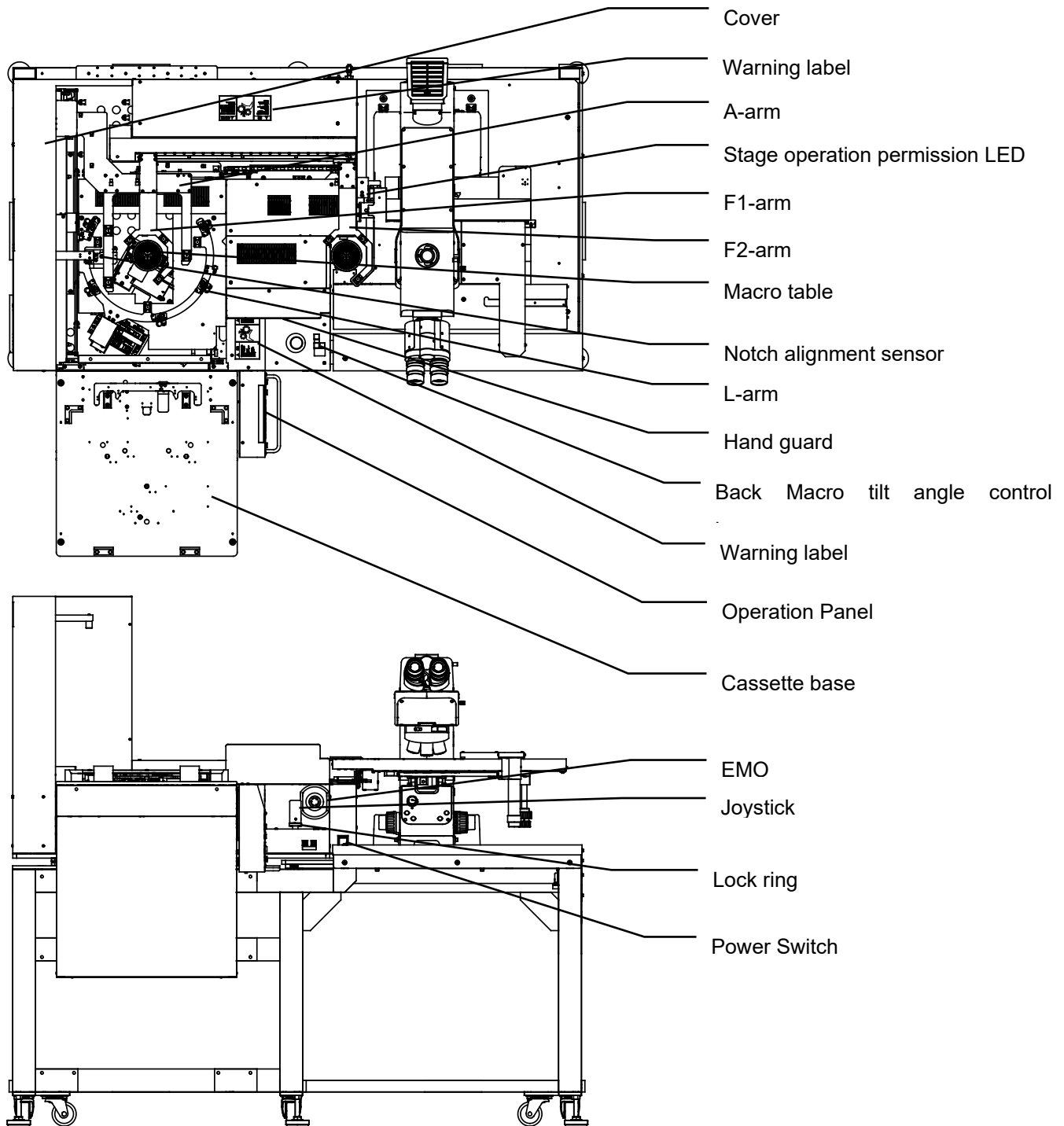

1-1-2 AL120-LMB12-LP3

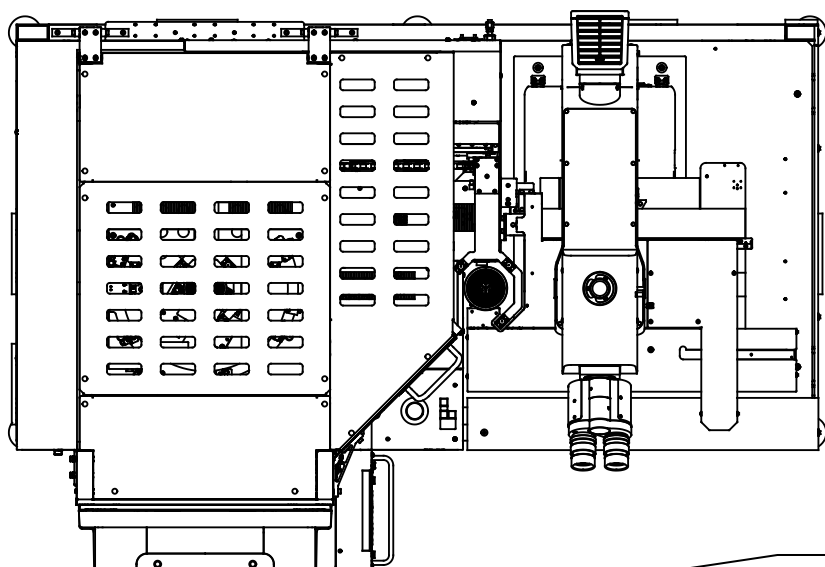

FOUP Opener

FOUP opener operation LED

Opening permission LED of the window

Inspection view window

Hand guard

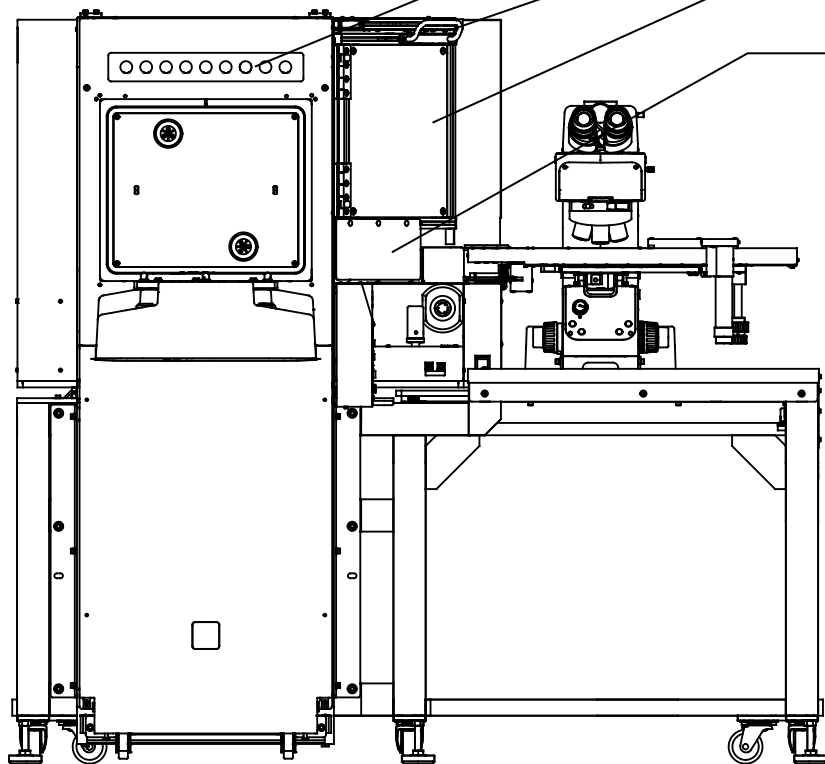

1-1-3 Back part [Main Disconnecter][AL120-LMB12-F]

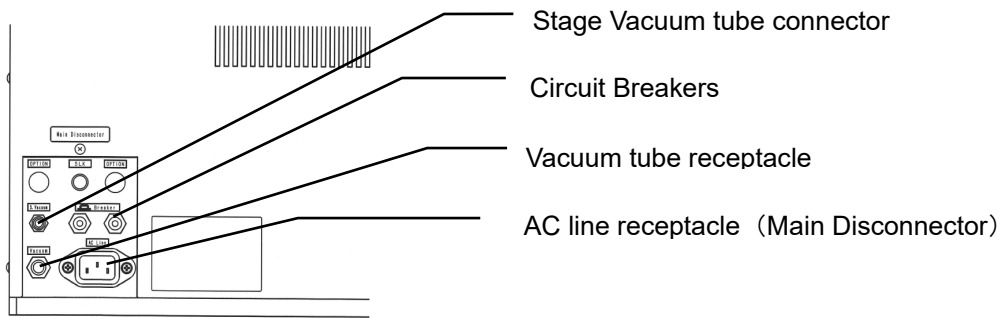

1-1-4 Back part [Main Disconnecter][AL120-LMB12-LP3]

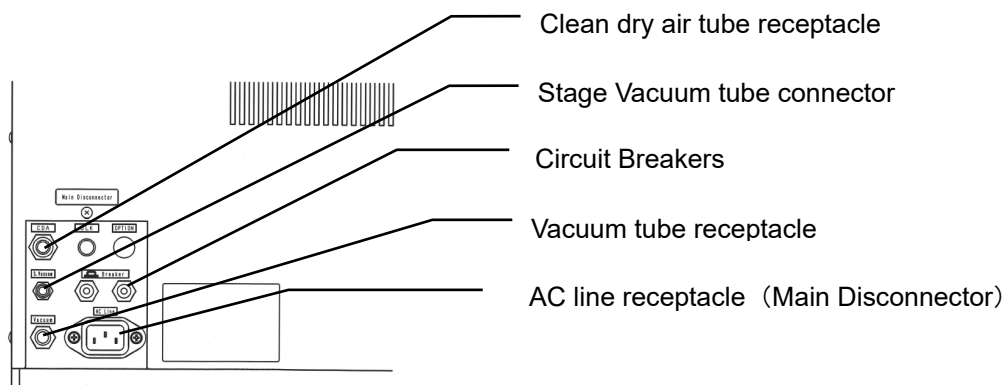

1-1-5 Operation Panel

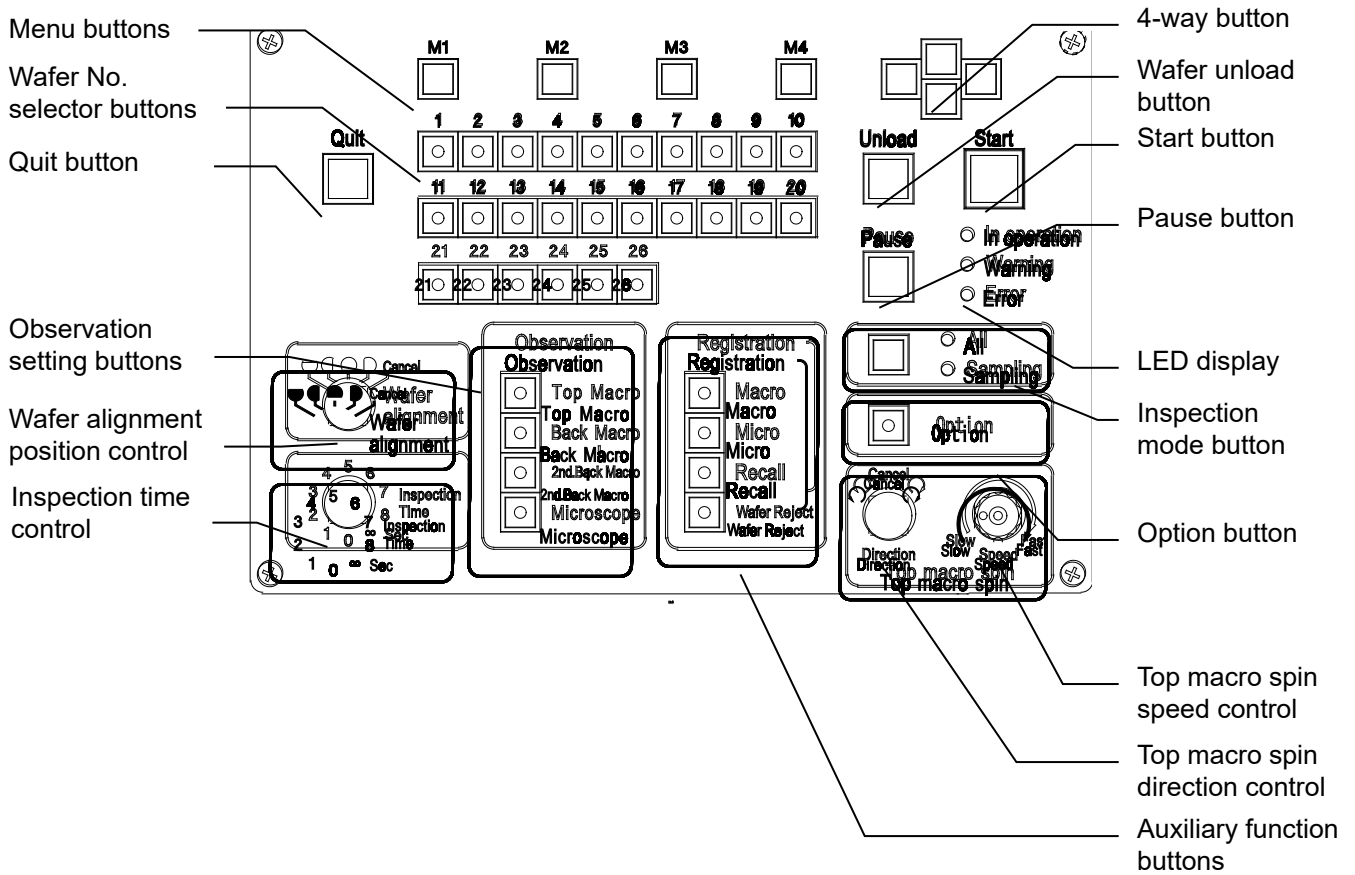

1-1-6 FOUP opener operation display panel

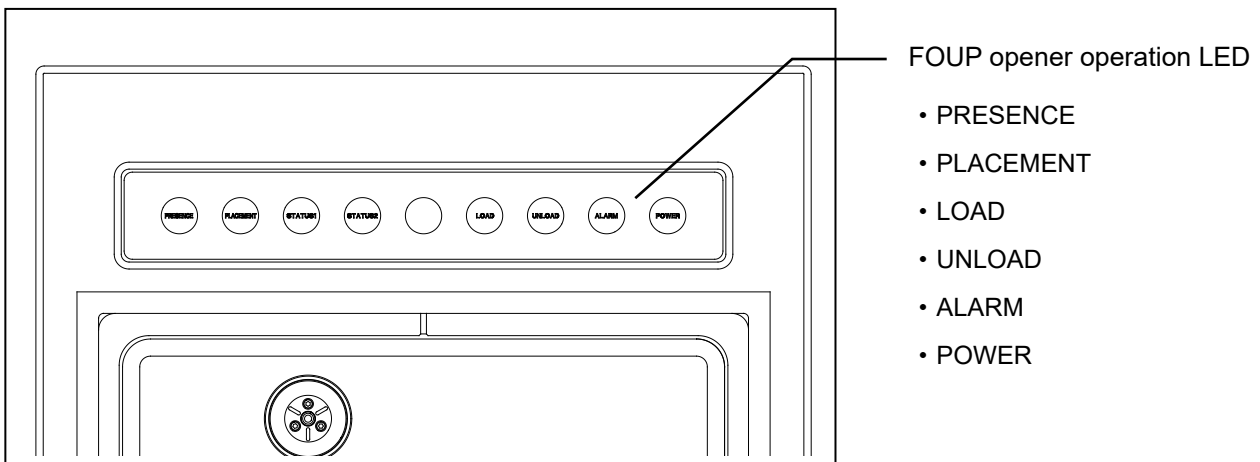

1-2 Remote Controller (Option)

Remote controller: AL120-RC

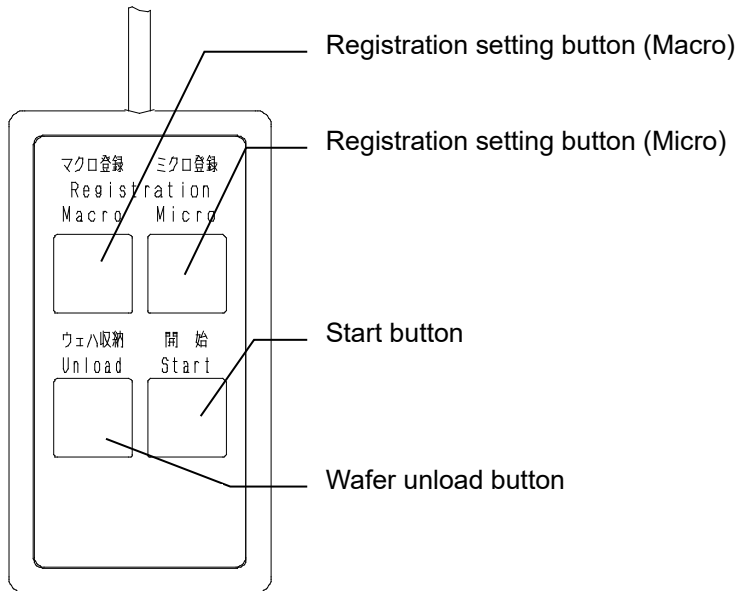



Vacuum Stage

Vacuum stage: AL120-VS12

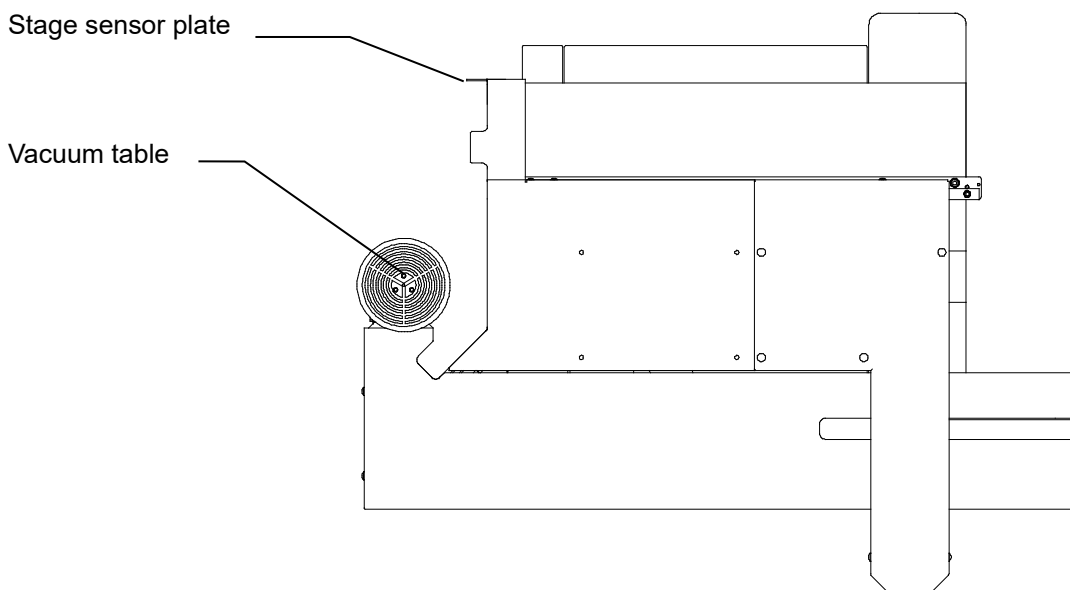
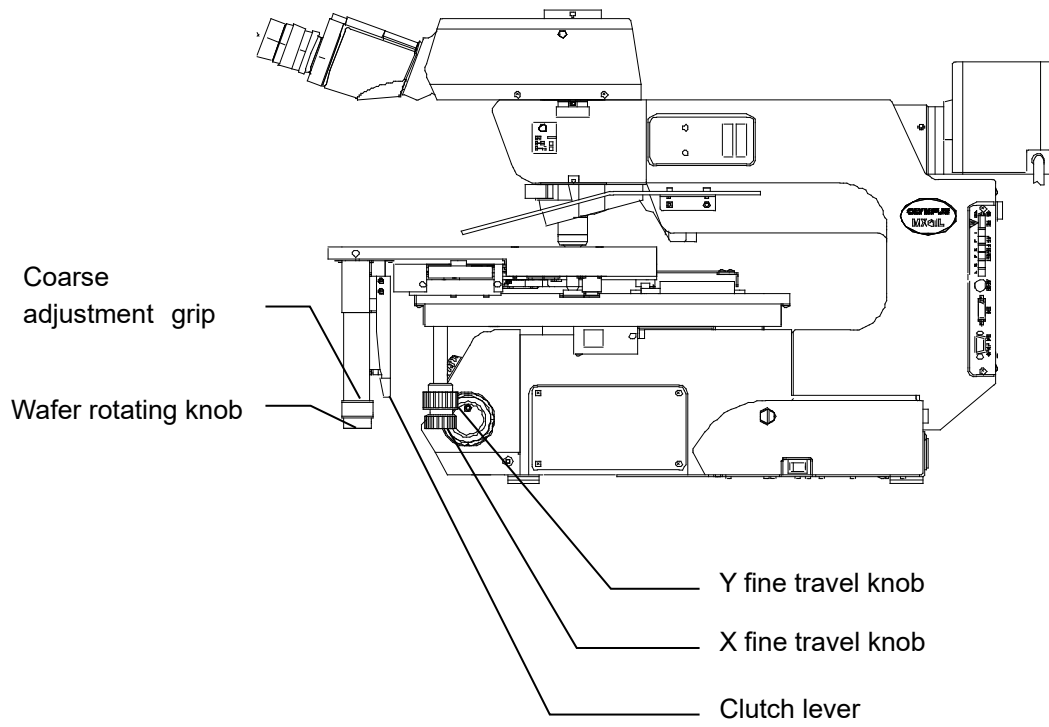

2 Outline of Operation Procedures

1 Description of Symbols

The meanings of the symbols used in Chapter 2 and are explained below.

[]: Indicates the name which is shown on the operation panel

Names in parentheses are the names shown on the wafer loader operation panel. For the names of the parts of the operation panel, please refer to section **1-1-5 Operation Panel**.

2 Operation Procedure

This section describes the operation procedure for the basic wafer inspections (registered in the menu mode).

NOTICE

**When you use any cassette or inspection wafers that are not registered in the menu mode, you need to newly register the inspection wafer.
For registration, please refer to “2 Registration of New Inspection Wafer Types (Cassettes to be Used and Wafer Thickness)” in “2 Adjustments” in the Maintenance Manual (page 2-1).**

The operation procedure flowchart is shown on the next page.

When selected, the Top Macro inspection, the Back Macro inspection, the 2nd Back Macro inspection and the Microscope inspection are repeated for the number of wafers to be inspected, as shown in the flowchart.

For details of each operation, refer to the reference pages and sections listed on the right-hand side of the flowchart.

If the wafer loader operation panel has been left untouched for about 10 seconds, it will automatically switch to standby mode and the liquid crystal panel will darken. In the standby mode, press one of the buttons on the operation panel (save for the Quit button, the Pause button, the Wafer No. selector button or the wafer unload button), and the operation panel will automatically return to normal mode and accept button input.



Operation Flow	Controls/Units	Reference page	section
Turn the main switch ON	Main switch	2-3	1
↓			
Set a cassette in place on the cassette table	Cassette guide and cassette setting	2-3	2
↓			
---- Select the type of inspection wafer	4-way button	2-5	4
---- Set the sequence (type of inspection)	[Observation] setup buttons	2-6	5
---- Set the inspection mode (All or Sampling)	Inspection mode button	2-7	6
---- Set the orientation flat and notch positions on the microscope	[Wafer alignment] position control	2-10	8
---- Set the inspection time	[Inspection Time] control	2-10	9
---- Set the wafer rotation direction during Top Macro inspection	[Top macro spin direction] control	2-10	10
---- Set the wafer rotation speed during Top Macro inspection	[Top macro spin speed] control	2-10	10
↓			
Press the Start button	[Start] button	2-14	1
↓			
FOUP Clamp, Dock, Latch open	AL120-LMB12-LP3 only		
↓			
Wafer mapping			
↓			
Start transfer			
Top Macro inspection	[Top macro spin direction] and [Top macro spin speed] settings can be changed		
Back Macro inspection	[Back Macro Tilt Angle] setting can be changed		
2nd Back Macro inspection	[Back Macro Tilt Angle] setting can be changed		
↓			
----- Set the vacuum stage in place	Transfer of wafer onto the vacuum stage	2-17	6
↓			
Microscope inspection			



2-1 Procedure before Starting Transfer

Preparation

Make sure that there are no wafers in the transfer path or on the vacuum stage.

If any wafer is in the transfer path, return the wafer to the cassette using tweezers or the like.

1 Turning the Main Switch ON: Main Switch

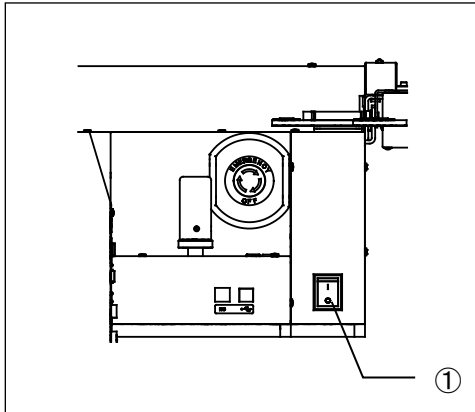

Turn the main switch ① ON.

If the units are not in the position, return to its initial position.(This is called initialization).

If the vacuum stage is not in the proper transfer position, the warning code W0002 is displayed. Set the vacuum stage in the transfer position.

2 Cassette Setting

AL120-LMB12-F

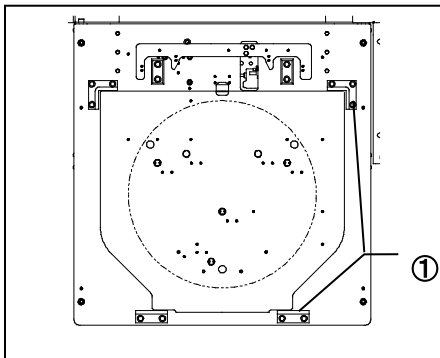

Set the cassette to the cassette guide①.

Please set the cassette to Kinematic coupling pins

Please make sure the lid at front side of FOSB has been open, when you set the cassette.



- Set the cassette carefully to prevent wafers from popping out.
 - If a deformed cassette is used, there is a risk that wafers could get damaged. When setting a cassette in position, make sure to see if the cassette rattles due to deformation.
 - We take no responsibility for the breakage of wafers or any other problems in setting the cassette.
 - AL120-LMB12-F is dedicated to FOSB.
- If you cannot set the cassette to Kinematic coupling pins, contact EVIDENT.



AL120-LMB12-LP3

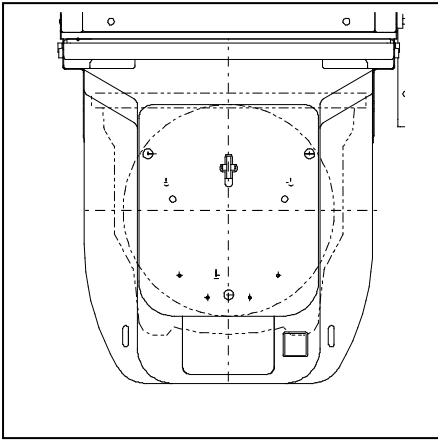

Please set the cassette to Kinematic coupling pins

3 FOUOP OPENER(AL120-LMB12-LP3)

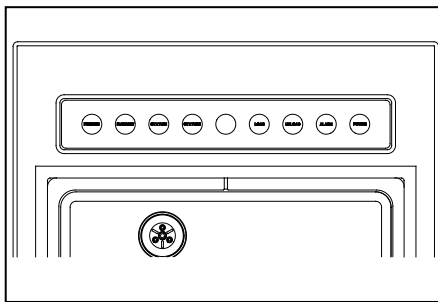

When the cassette is set to the correct position, "PRESENCE" "PLACEMENT" of "FOUOP OPENER OPERETION LED" light is on.

[PRESENCE]

[PLACEMENT]

When the start button of the Operation panel of is pushed, inspection starts.



- Be careful not to have hand pinched. Cassette is moving to back and forth when inspection gets started and finished .
- In LOAD and UNLOAD LED on the FOUOP opener is blinking. Make sure to check if UNLOAD-LED is off before unloading the cassette.

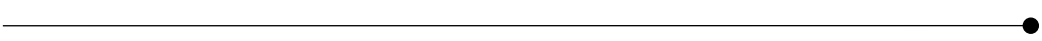

4 Selecting the Type of Inspection Wafer: 4-way button

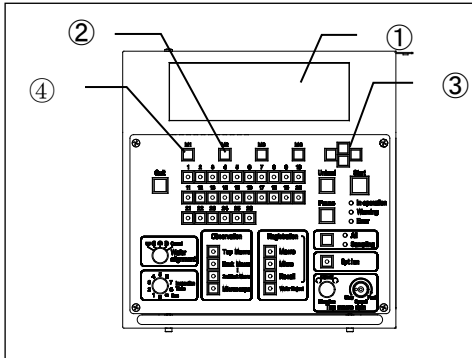

The initial menu appears on the liquid crystal panel ①.

- 1) To change the type of inspection wafer shown on the liquid crystal panel ①, press the [M2] ② <Wafer> button to bring the inspection wafer type selection screen.
- 2) Press the 4-way button ③, and the <x> mark moves to the number of the inspection wafer already registered.
Move <*> to the number of the type of wafer to be inspected, and press the [M1] ④ <OK> button to determine the setting.

* Your loader may only have a setting for one type of wafer.

```
AL120-LMB12-LP3    ALL
Press Start button
No|size|Thick  |comment
1.|300 |775-500 |
Recall Wafer  Setting Memory
```

```
No |Size|Thick |Speed|comment
x1 | 300|775-500 |High |
 2 | 300|775-500 |High |
 3 | 300|775-500 |High |
 4 | 300|775-500 |High |
 5 | 300|775-500 |High |
 6 | 300|775-500 |High |
OK  Cancel PageUp PageDn
```

```
No |Size|Thick |Speed|comment
x1 | 300|775-500 |High |
OK  Cancel PageUp PageDn
```

* Indication example when a setting for one type of wafer.

5 Setting the Sequence (Inspection Type: [Observation] Button)

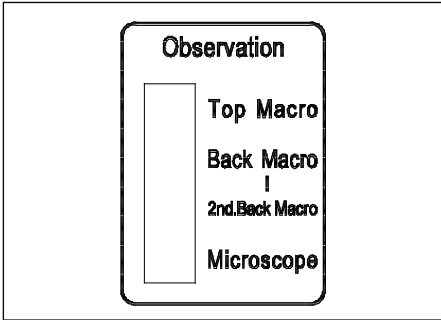

The [Observation] setting buttons are used to specify an inspection sequence.

Specify the inspection sequence before initiating inspection. The selected sequence cannot be changed once inspection is started. The LEDs in the selected [Observation] setting buttons light up.

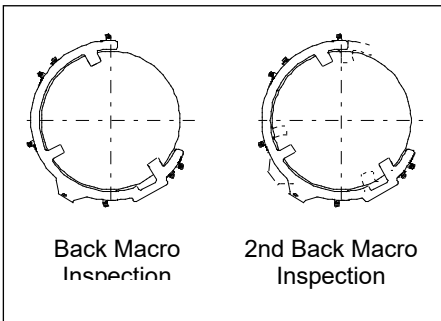

The 2nd Back Macro inspection performs the Back Macro inspection again with the wafer rotated about 20 degrees counterclockwise on the macro table after the Back Macro inspection is completed. The 2nd Back Macro inspection enables inspection of the areas hidden by the rear arm during the Back Macro inspection.

The 2nd Back Macro inspection can be selected only when the Back Macro inspection is selected.

6 Setting the Inspection Mode

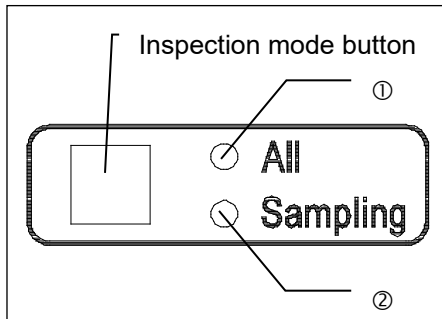

The following three inspection modes can be chosen.

- All (100%) inspection
- Sampling transfer P1 to P10 (Transfer pattern registration)
- Sampling inspection L1 to L10 (Inspection pattern registration)

(1) All (100%) inspection:

Press the inspection mode button to turn on the [All] LED ①.

(2) Sampling transfer P1 to P10 (Loading pattern registration):

1) Operation procedure

The loader can only transfer a wafer in the specified slot in the cassette.

- Press the inspection mode button until the desired pattern number from P1 to P10 appears on the liquid crystal panel. (The [Sampling] LED ② lights up.)

The number increases incrementally from P1 to P10 each time the up or down button of the 4-way button is pressed.

The number jumps from P1 to P5 and P5 to L1 as the right or left button of the 4-way button is pressed.

- The inspection sequence to be used is the one established before the [Start] button is pressed.
- Ten patterns can be registered in slots P1 to P10.
- Two wafers are transferred at a time. (While one wafer is under Micro inspection, the next wafer is transferred to the Macro inspection position.)

2) How to register sampling loading patterns (P1 to P10)

- Press the inspection mode button until the desired pattern number from P1 to P10 is displayed on the liquid crystal panel.
- Press the [M3] <Setting> button to display the setting registration screen.
- Specify the number of the wafer to be selectively transferred by using the Wafer No. selector button. (The LED in the selected Wafer No. selector button lights up.)

```
AL120-LMB12-LP3  P5
Press Start button
No|Size|Thick  |Comment
1.|300 |775-500 |
Recall Wafer  Setting  Memory
```

```
Inspection      P5
  1-10      11-20      20-26
  1234567890 1234567890 123456
Wafer 0000000000 0000000000 000000
Exit      Setting Memory
```



The button is alternately selected and deselected each time it is pressed.

- After the setting is completed, press the [M4] <Memory> button. A buzzer sounds to indicate that registration is complete.
- Press the [M1] <Exit.> Button to exit the setting registration screen.

(3) Sampling inspection patterns (L1 to L10)

1) Operation procedure

The loader can inspect only a wafer in the specified slot in the cassette according to a specified inspection sequence.

- Press the inspection mode button to display the pattern number (L1 to L10) that you want to register on the liquid crystal panel.

(The [Sampling] LED  lights up.)

The number increases incrementally from P1 to P10 each time the up or down button of the 4-way button is pressed.

The number jumps from P1 to P5 and P5 to L1 as the right or left button of the 4-way button is pressed.

- Ten patterns can be registered in slots L1 to L10.
- One wafer is transferred at a time.

2) How to register sampling inspection patterns (L1 to L10)

- Press the inspection mode button to display the pattern number (L1 to L10) that you want to register on the liquid crystal panel.
- Press the [M3] <Setting> button to display the setting registration screen.
- Specify the number of a wafer to be subjected to sampling inspection with the [Wafer No.] button. The selected Wafer No. selector button will blink. Specify the inspection sequence for the selected wafer number and the LED in the selected inspection sequence button lights up. (The inspection sequence button is alternately selected and deselected each time it is pressed.)
- If you want to register other wafer numbers, specify the wafer numbers and the inspection sequence by using the [Wafer No.] buttons in the same way as described above.

AL120-LMB12-LP3 L1			
Press Start button			
No	Size	Thick	Comment
1.	300	775-500	
Recall	Wafer	Setting	Memory

	1-10	11-20	20-26
	1234567890	1234567890	123456
Macro	0000000000	0000000000	000000
Back	0000000000	0000000000	000000
Back2	0000000000	0000000000	000000
Micro	0000000000	0000000000	000000
Exit		Setting Memory	





The [Wafer No.] buttons are on for the numbers of wafers whose inspection sequences are already specified.

If you press the [Wafer No.] button for a wafer for which the inspection sequence is already specified, the LED in the specified inspection sequence button lights up.

With the LED turned on this way, you can change the inspection item by pressing the inspection sequence button. (Each time the inspection sequence button is pressed, the specified inspection sequence is alternately selected and deselected.)

* If the [Wafer No.] button for a wafer whose inspection sequence is already specified is pressed twice, the inspection sequence setting for this wafer number is cleared and the LED in the [Wafer No.] button goes off.

- After the settings have been completed, press the [M4]: <Memory> button. As the buzzer sounds, the registration process is completed.
- Press the [M1] <Exit> button to exit the setting registration screen.

7 Selecting Wafers for Inspection: Wafer No. Selector Button

You can specify the number of the wafer to be inspected in the sampling mode.

The button is alternately selected and deselected each time it is pressed. The LED in the selected button lights up.

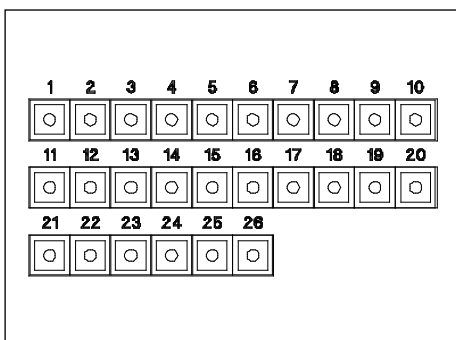

- Before the start of inspection, the LED in the Wafer No. selector button lights up to indicate that the corresponding wafer is to be inspected.
- During inspection, the LED in the Wafer No. selector button blinks.
- At the end of inspection, the LED in the Wafer No. selector button turns off.

This loader supports 25 wafers.

The button for the 26th wafer will not work even if pressed.

8 Setting the Orientation Flat and Notch Positions on the Microscope: [Wafer alignment] Position Control

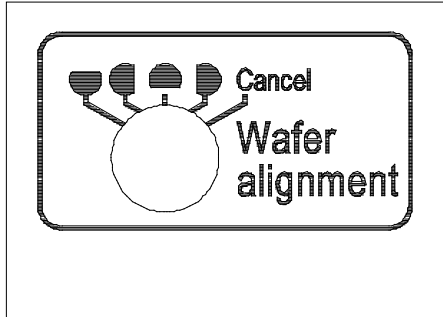

The orientation flat alignment position can be set to either four different points at intervals of 90 degrees (top, bottom, left and right), or to none.

The symbols on the operation panel indicate the orientation flat alignment positions on the vacuum stage.

Change the orientation flat alignment position before starting the orientation flat alignment operation. (Settings can be changed at any time.)

9 Setting the Inspection Time: [Inspection Time] Control

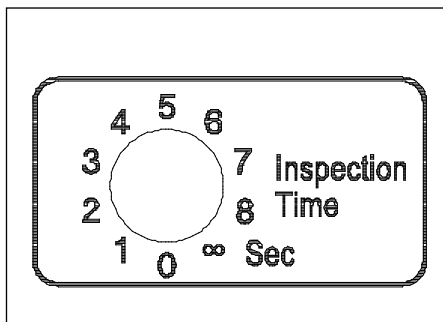

The time for holding a wafer in the inspection position can be set from 0 to 8 seconds (in 1-second steps), or to ∞. (Settings can be changed at any time.) Even during this period, the loader will proceed to the next operation when the [Start] button or the [Unload] button is pressed, or when the vacuum stage is set.

Setting the inspection time to 0 (zero) seconds disables the macro registration function.

If the inspection time is set to [∞], rotation is temporarily stopped when the Top Macro inspection has been left for more than one minute.

The operation is restarted by pressing the [Start] button.

10 Detailed Settings for the Top Macro Inspection: [Top macro spin direction] and [Topmacro spin speed] Controls

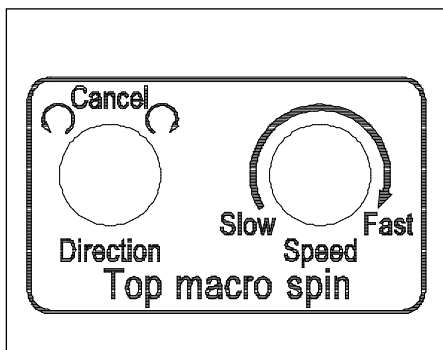

(1) The [Top macro spin direction] control can be set to a wafer rotation to the left or to the right, or to no rotation during the Top Macro inspection. (Settings can be changed at any time.)

(2) The [Top macro spin speed] control can be set to a wafer rotation speed of from 3 to 30 seconds per rotation during the Top Macro inspection. (Settings can be changed at any time.)

11 Setting Wafer Alignment when Unloading a Wafer

When putting an inspected wafer into a cassette, the position of its orientation flat can be specified.

```
AL120-LM12-LP3    ALL
Press Start button
No|Size|Thick  |Comment
1.|300|775-500  |
Recall Wafer  Setting Memory
```

```
Inspection      ALL
   1-10        11-20    20-26
1234567890 1234567890 123456
Wafer 0000000000 0000000000 000000
Exit          Setting Memory
```

```
Condition setting
Alignment unloading      :Disable
Direction of orientation flat:Disable
Save Cancel
```

- (1) Displaying the setup screen
 - 1) When you are in the initial menu of the liquid crystal panel, press the [M3] <Setting> button.
 - 2) When the submenu is displayed, press the [M3] <Setting> button.
 - 3) The setup screen is displayed.

Move <X> to the setting you are dealing with by manipulating the up and down buttons of the 4-way button.

Move the cursor to the values of each item to be set by operating the right and left buttons of the 4-way button, and change the values with the up and down buttons of the 4-way button.

 - Centering a wafer when unloading <Centering unloading>:

Disable or Enable
 - Performing orientation flat alignment when unloading <Alignment unloading>:

Disable or Enable
 - Setting the direction of orientation flat <Direction of orientation flat>

On the cassette opening side: [Front]

On the opposite side of the cassette opening: [Rear]

On the right side as seen facing the cassette opening:

[Right]

On the left side as seen facing the cassette opening:

[Left]

- 4) Press the [M1]: <Save> button to register the wafer alignment setting. This completes the wafer alignment setting at unloading.

To exit without registering the wafer alignment setting (without changing the current setting), press the [M2]: <Cancel> button.

2-2 Vacuum Stage

1 How to Move the Vacuum Stage

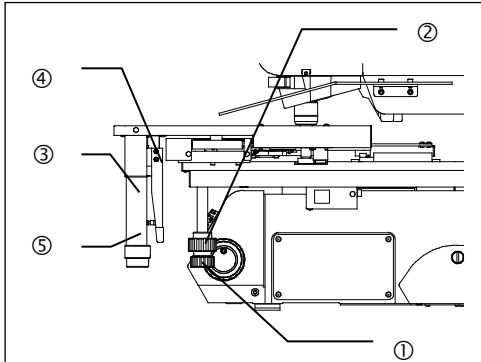

The vacuum stage can be moved by rotating the X fine travel knob ① and the Y fine travel knob ② in the lower right section of the stage. One turn of each knob moves the stage approx. 50 mm in the Y-axis direction or approx. 37 mm in the X-axis direction.

2 How to Use the Grip Handle

The drive of the X fine travel knob can be released by fully depressing the clutch ④ of the grip handle ③. While this clutch remains depressed, the stage can be moved freely.

NOTICE

- Moving the stage without depressing the clutch will affect fine travel accuracy.
- Forcing the grip handle downward will affect vacuum stage accuracy and damage the stage.

- Adhesion of clutch and belt

When the stage is left unmoved for long periods, the clutch and belt will adhere to each other. This could hinder smooth drive release operations. To fix this, fully depress the clutch while holding the X fine travel knob so that it cannot rotate, and move the lever from side to side.

3 How to Use the Wafer Rotating Knob

A wafer can be rotated 360 degrees by rotating the wafer rotating knob ⑤ in the lower section of the grip handle.

One turn of the knob rotates the wafer approx. 180 degrees.

2-3 Start of Transfer

1 Start of Transfer: [Start] Button

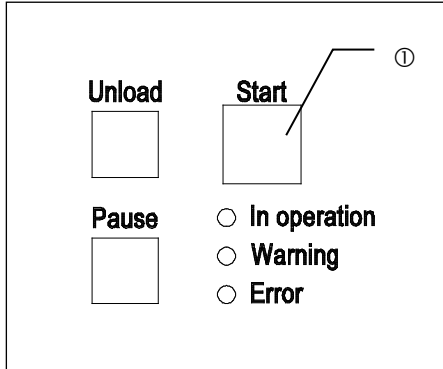

Press the [Start] ① button to start inspection.

- You can also start inspection using the remote controller.
- Inspection starts when the stage is set to the wafer transfer position, even if the Microscope operation is not selected.
 - * This function can be disabled by changing the setting.
- The loader may have been set to start inspection only after the type of inspection wafer is specified.

2 Status of the Loader in Operation

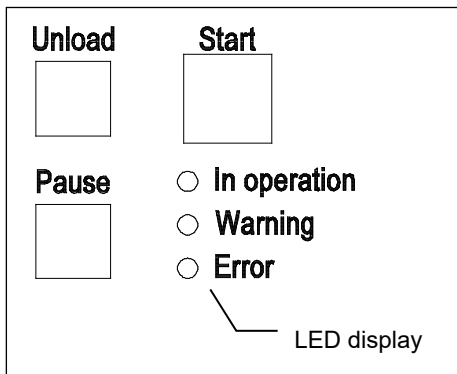

The status of the loader is indicated by LED lighting.

- “In operation”: Lit green to indicate that the loader is in operation.
- “Warning”: Lit yellow to indicate a warning.
- “Error”: Lit red and with a buzzer to indicate that an error has occurred.

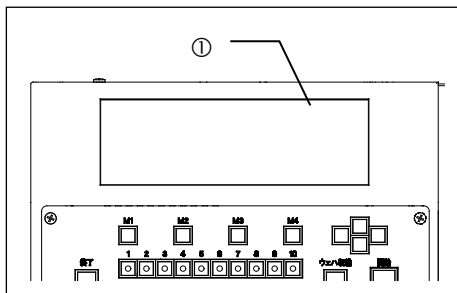

The liquid crystal panel ① shows the following information.

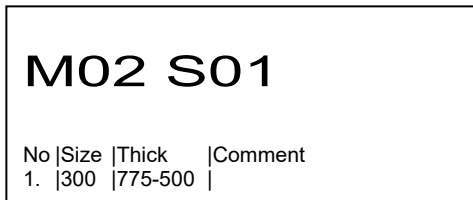

- When the loader is in operation: The panel shows the number of the wafer currently inspected in each inspection position.

On the macro (center) table <M**>

On the vacuum stage <S**>

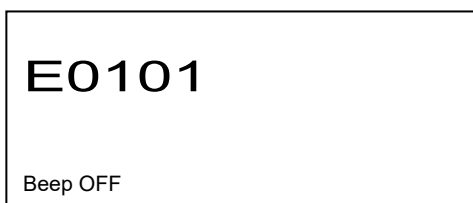

- When a warning has occurred: The panel shows the warning code number.
- When an error has occurred: The panel shows the error code number.

You can silence the buzzer by pressing [M1] <OFF>.

3 Top Macro Inspection

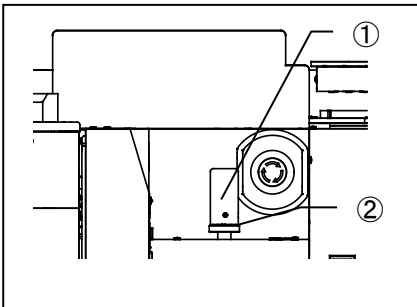

- 1) By tilting the joystick wafer is tilted in surface macro inspection. The wafer can be tilted to Omni direction. maximum 20 degree
- 2) The joystick is locked when its lock ring ② is rotated clockwise. (Use the lock ring to continue inspection at the same tilt angle.)

NOTICE

- Forcibly operating a locked joystick will weaken the locking force and make the joystick unable to hold a fixed position.
- If the joystick is operated abruptly, a wafer may bump into the arm. Operate the joystick at 20 degrees per second or slower.

4 Back Macro Inspection and 2nd Back Macro Inspection: Setting the Back Macro Tilt Angle

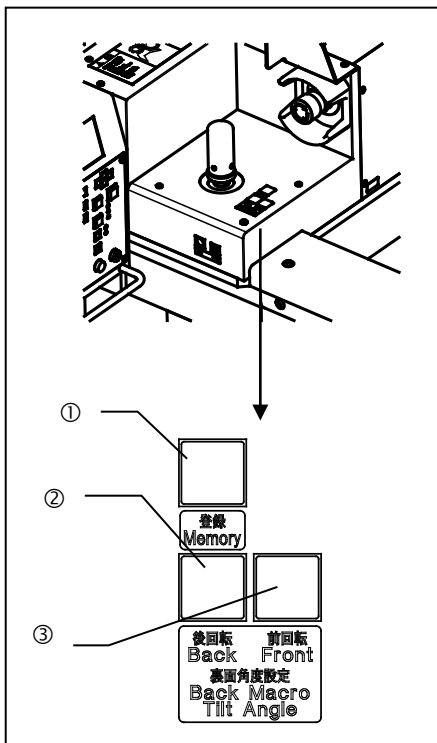

- 1) The Back Macro Tilt Angle setting buttons can be reset in a 360 degree range during inspection.
- 2) The tilt angle can be changed by using the angle setting buttons ② and ③.
 - ②: Back rotation
 - ③: Front rotation
- 3) One tilt position can be registered. Move the wafer to the desired tilt angle using the Back Macro Tilt Angle setting buttons, and then press and hold down the Memory button ① until the buzzer sounds.

NOTICE

- Do not push the bottom of the wafer firmly during the back macro test. It may cause wafer drops from the L-Arm.

5 Observation window for macro inspection (AL120-LMB12-LP3)

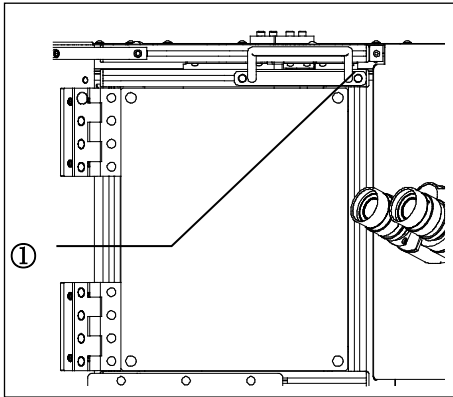

- 1) The macro observation window can be open during macro inspection.

Make sure to close the macro observation window after macro inspection.

If it remains open error code "W0003" shows.



Do not get a hand caught in the lid of FOUP opener, it may cause serious injury.

For your safety, macro observation window is locked except macro inspection.

Do not open the macro observation window when it is locked. If you try to open the window forcibly, the system may get damage.

6 Transferring a Wafer onto the Vacuum Stage

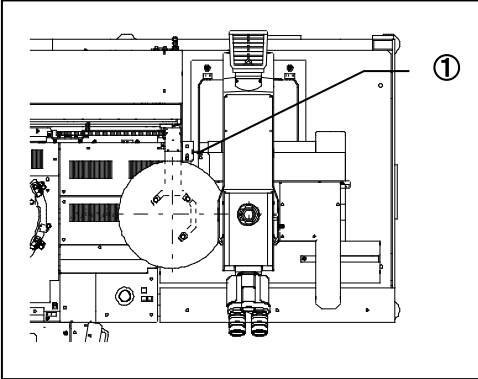

To transfer a wafer onto the vacuum stage during the Microscope inspection, move the vacuum stage to the loader.

Stage Operation Permission LED turns green on the detection sensor of the stage when F-arm finished descended.

The vacuum stage cannot be in use when Stage Operation Permission LED ① is turned OFF.

By selecting 「Buzzer ON」 in the system setting buzzer is generated when the stage is ready to move

In the inspection sequence composed of the Top Macro inspection, the Back Macro inspection and the Microscope inspection, when the vacuum stage is moved to the wafer transfer position during the Top Macro inspection, the loader can proceed to the Microscope inspection by interrupting the Back Macro inspection.

NOTICE

- Do not move the vacuum stage until the Stage Operation Permission LED lights up. Moving the stage is dangerous as a wafer may be released for transfer. If the stage is moved during transfer, a wafer may be transferred in an incorrect position and be damaged.
- If the vacuum stage is moved before the stage up and down movement is completed, the warning W0002 is shown on the liquid crystal panel.

7 Temporarily Registering the Inspection Results: [Registration] Button

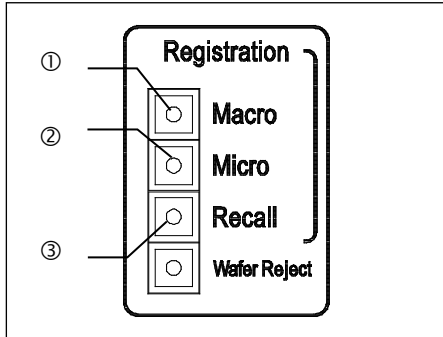

The [Macro] ① and [Micro] ② buttons are used to register defective wafers. The registered wafers can be confirmed by pressing the [Recall] ③ button after the inspection is completed.

You can also perform this operation using the remote controller.

(1) How to register

- Press the [Macro] ① button to register wafers under Top Macro or Back Macro inspection. Press the [Micro] ② button to register wafers under Microscope inspection.

The buzzer sounds when registration is complete.

- Wafers can be registered only during inspection but cannot be registered during wafer transfer. If registration is needed, set the inspection time to 1 second or longer. (The inspection time setting function is not available for the L model.)
- Two wafers at a time are transferred when the inspection mode is All or Sampling (P1 to P10). Wafers on the microscope cannot be registered after the specified inspection time has elapsed. If registration is needed, set the inspection time to ∞.

(2) How to confirm

- After inspection is completed, press the menu button [M1] <Recall> in the liquid crystal panel operating part or the [Recall] ③ button in the operating panel. The liquid crystal panel shows the registered data for each type of inspection. <1> is displayed for the registered wafer number.
- After confirmation, press the menu button [M1] <Exit> in the liquid crystal panel operating part. The loader returns to the initial screen and is ready for inspection.

Registered data remains in the memory until the main switch is turned OFF or the next inspection is started.

AL120-LMB12-LP3		ALL	
Press Start button			
No	Size	Thick	Comment
1.	300	775-500	
Recall	Wafer	Setting	Memory

NG Wafer	0.OK	1.NG	
	1-10	11-20	20-26
	1234567890	1234567890	123456
Macro	0000000000	0000000000	000000
Back	0000000000	0000000000	000000
Back2	0000000000	0000000000	000000
Micro	0000000000	0000000000	000000
Exit			

2-4 Stoppage of Transfer

1 Temporarily Stopping the Loader during Inspection: [Pause] Button

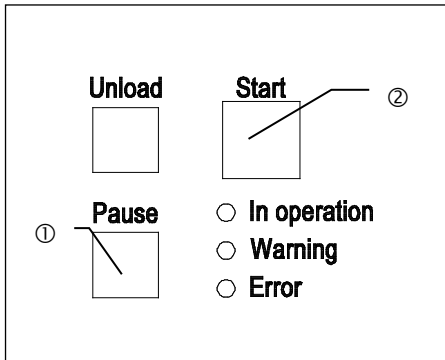

The [Pause] ① button stops the wafer in the inspection position and cancels the inspection time setting.

The LED in the [Pause] ① button blinks during a pause. The loader will proceed to the next inspection when the [Start] ② button is pressed. The [Pause] ① button does not work when the inspection time is set to ∞.

2 Removing a Wafer with Tweezers during Inspection: [Wafer Reject] Button

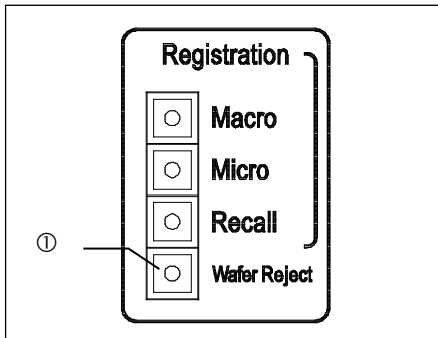

The [Wafer Reject] ① button is used to remove a wafer in the inspection position. When the wafer is made removable by pressing the [Wafer Reject] ① button, the LED in the [Wafer Reject] button blinks. To remove a wafer, press the [Wafer Reject] ① button while the [Pause] button is pressed or while the wafer is waiting for a start command input with an inspection time of ∞. You can remove wafers which have numbers shown on the liquid crystal panel.

- The position from which a wafer can be removed differs depending on the sequence setting and the state of wafer transfer.

(1) When a wafer is on the stage, the wafer on the stage will be removed.

Press the [Wafer Reject] ① button, and you can remove a wafer from the vacuum stage. As you set the vacuum stage on the loader after removing a wafer, the next wafer will be automatically transported to the position where inspection is performed.

(2) If a wafer is located only at the position where macro inspection is performed, the wafer at this position is to be removed.

Press the [Wafer Reject] ① button, to remove a wafer. As you press the [Start] button after removing a wafer, the next wafer will be automatically transported to the position where inspection is performed.

3 Unloading a Wafer during Inspection: [Unload] Button

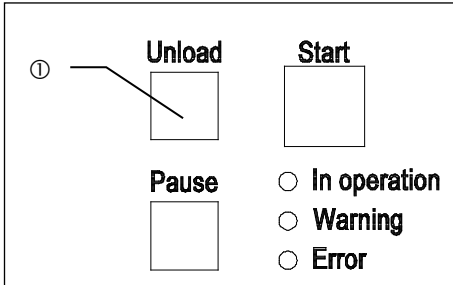

The [Unload] ① button is used to unload a wafer from the transfer path in the loader (in the Top or Back Macro inspection position) into the cassette and transfer the next wafer. This operation is possible only when two or more types of inspection are selected in the sequence.

You can also perform this operation using the remote controller.

4 EMO: [EMERGENCY OFF] Button

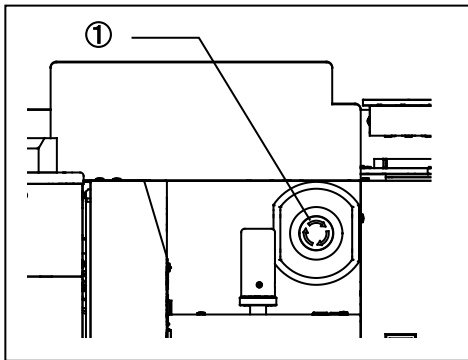

By pressing the [EMERGENCY OFF] button ① the system can be powered off.

Make sure to check the Main switch is turned OFF before unlock the [EMERGENCY OFF] button.

In order to unlock the [EMERGENCY OFF] button rotate its knob to clockwise.

If there are any wafers in the transfer path, refer to section 5-6 **Automatic Unloading**.

5 Terminating the Inspection: [Quit] Button

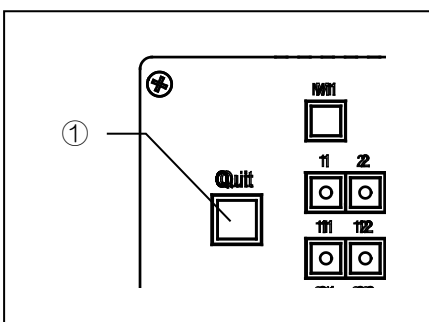

Pressing the [Quit] ① button terminates inspection halfway, unloads the inspected or transferred wafers into the cassette, and returns the loader to its initial state.

3 Inspections

3-1 Preparations

1. Make sure that there are no wafers in the transfer path or on the vacuum stage.
If there are any wafers in the transfer path, return them to the cassette using tweezers or similar.
 2. Turn the main switch ON.
The A-arm, the F-arm, the L-arm, the wafer presence sensor and other units return to their initial positions if they are in other positions.
- * The loader can be set to skip initialization when power is turned on. (Refer to the test mode in the maintenance material.)
 - * Wafers are not transferred to the microscope if the vacuum stage is not in the proper transfer position.
Set the vacuum stage to the transfer position.

3-2 Inspection Operations

3-2-1 Microscope Inspection

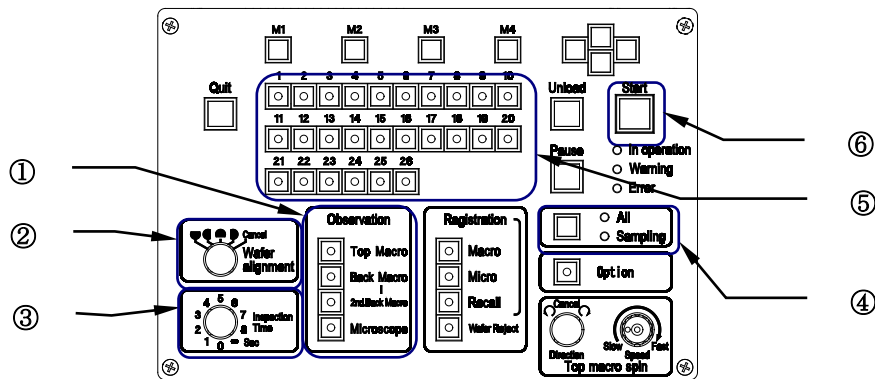

1. Set a cassette on the cassette table.
2. Make sure that the [Microscope] LED in the Observation button is lit. ①
If the [Microscope] LED is not lit, press the button to turn on the LED. If LEDs for other types of inspection are lit, turn them off by pressing their buttons.
3. Confirm the detailed settings for inspection.
 - 1) [Wafer alignment]: Indicates the setting position of where the orientation flat/notch positions on the stage. ②
 - 2) [Inspection Time]: Must be set to ∞ (infinite) when only the Microscope inspection is performed. ③
4. Set and confirm the inspection mode.
Select All or Sampling (P1 to P10). ④
Set the inspection wafer number(s) as needed. ⑤



5. Set the vacuum stage to the wafer transfer position of the main unit.
If the vacuum stage has already been set in place, reset it or press the [Start] button.Ⓢ
6. The first wafer is transferred from the cassette. After the notched alignment (when it is selected), the wafer is transferred onto the vacuum stage.
Do not move the stage until the wafer has completely transferred onto the vacuum stage.
After the transfer is completed, the loader is able to perform the Microscope inspection of the first wafer.
7. The second wafer is transferred from the cassette. After the notched alignment (when it is selected), the wafer waits for inspection.
8. When the first wafer inspection is completed, the inspected wafer is replaced by the second wafer after the vacuum stage is set to the wafer transfer position.
If the first wafer inspection has already been completed and the vacuum stage has been set to the wafer transfer position before the second wafer is ready, reset the stage or press the [Start] button.
9. The first wafer is unloaded into the cassette.
10. The third wafer is transferred from the cassette. After the orientation flat alignment, the wafer waits for inspection. Steps 7 to 9 are repeated to transfer subsequent wafers for inspection.
11. After the last wafer is unloaded into the cassette, the operating units return to their initial positions and the loader stops.
12. Replace the cassette with the next one, and repeat the procedure from step 1.

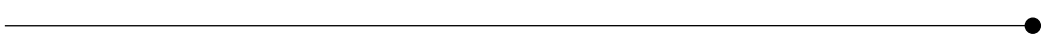

3-2-2 Top Macro Inspection

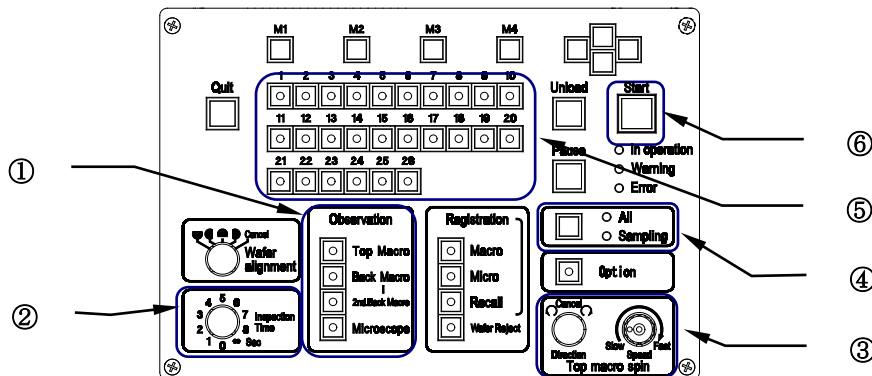

1. Set a cassette on the cassette table.
2. Make sure that only the [Top Macro] LED in the Observation button is lit..... ①
If the [Top Macro] LED is not lit, press the button to turn on the LED. If LEDs for other types of inspection are lit, turn them off by pressing their buttons.
3. Confirm the detailed settings for inspection.
 - 1) [Inspection Time]: Enables the setting of Macro inspection time. ②
 - 2) [Top Macro spin direction]: Enables the setting of wafer rotation direction during the Top Macro inspection..... ③
 - 3) [Top Macro spin speed]: Enables the setting of wafer rotation speed during the Top Macro inspection.③
4. Set and confirm the inspection mode.
Select All or Sampling (P1 to P10)..... ④
Set the inspection wafer number(s) as needed..... ⑤
5. Press the [Start] button, and the first wafer is transferred to the Top Macro inspection position. ⑥
You can change the wafer tilt direction for observation using the joystick.
Release the lock ring before using the joystick.
6. After the specified inspection time has elapsed, the wafer is unloaded into the cassette, and the second wafer is transferred to the Top Macro inspection position.
* Press the [Start] button if the [Inspection Time] control is set to [∞].
7. Subsequent wafers are transferred automatically and sequentially.
8. After the last wafer is unloaded into the cassette, the operating units return to their initial positions and the loader stops.
9. Replace the cassette with the next one, and repeat the procedure from step 1.

3-2-3 Back Macro Inspection

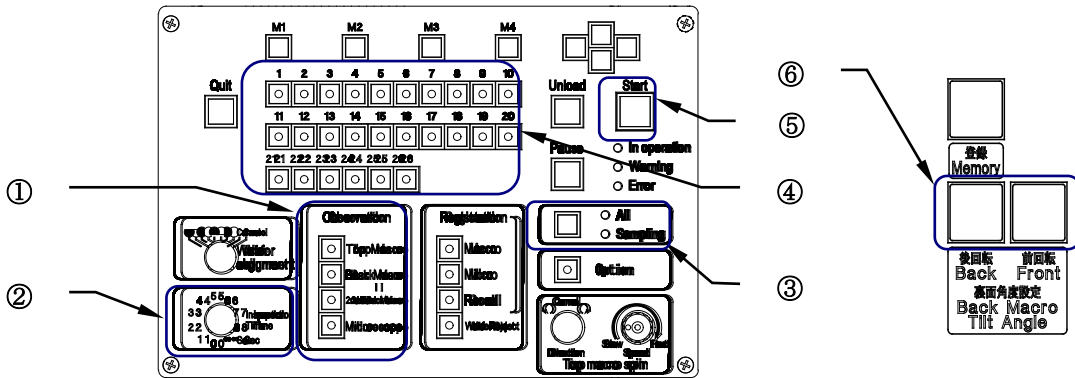

1. Set a cassette on the cassette table.
2. Make sure that only the [Back Macro] LED in the Observation button is lit. ①
If the [Back Macro] ED is not lit, press the button to turn on the LED. If LEDs for other types of inspection are lit, turn them off by pressing their buttons.
3. Confirm the detailed settings for inspection.
 - 1) [Inspection Time]: Enables the setting of Macro inspection time. ②
* The inspection time is common to the Top Macro and Back Macro inspections.
4. Set and confirm the inspection mode.

Select All or Sampling (P1 to P10). ③

Set the inspection wafer number(s) as needed. ④
5. Press the [Start] button to transfer the first wafer to the Back Macro inspection position. ⑤
You can change the wafer tilt position (angle) for observation using the [Back Macro Tilt Angle] button. ... ⑥
6. After the specified inspection time has elapsed, the wafer is unloaded into the cassette, and the second wafer is transferred to the Back Macro inspection position.

* Press the [Start] button if the [Inspection Time] control is set to [∞].
7. Subsequent wafers are transferred automatically and sequentially.
8. After the last wafer is unloaded into the cassette, the operating units return to their initial positions and the loader stops.
9. Replace the cassette with the next one, and repeat the procedure from step 1.

3-2-4 Back Macro Inspection + 2nd Back Macro Inspection

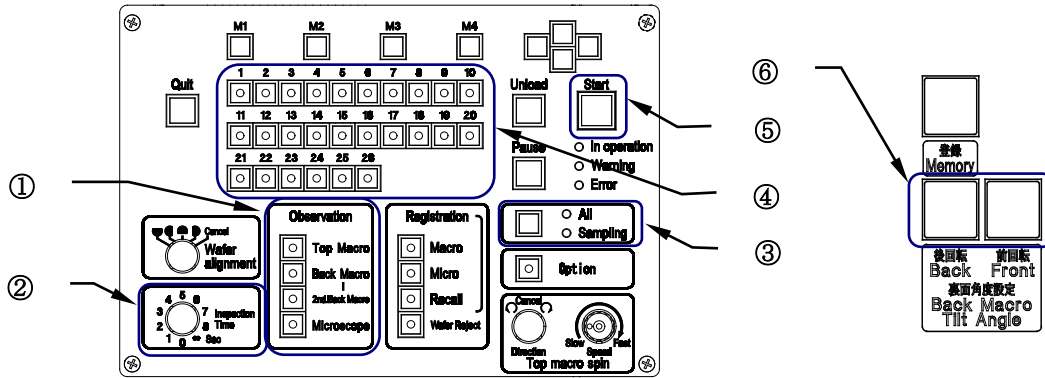

1. Set a cassette on the cassette table.
2. Select the [Back Macro] and [2nd Back Macro] Observation buttons. ①
 When the buttons are selected, the LEDs in the buttons light up.
 If the [Back Macro] and [2nd Back Macro] LEDs are not lit, press the buttons to turn on the LEDs. If LEDs for other types of inspection are lit, turn them off by pressing their buttons.
3. Confirm the detailed settings for inspection.
 - 1) [Inspection Time]: Enables the setting of Macro inspection time. ②
 * The inspection time is common to the Top Macro, Back Macro and 2nd Back Macro inspections.
4. Set and confirm the inspection mode.
 Select All or Sampling (P1 to P10). ③
 Set the inspection wafer number(s) as needed. ④
5. Press the [Start] button to transfer the first wafer to the Back Macro inspection position. ⑤
 You can change the wafer tilt position (angle) for observation using the [Back Macro Tilt Angle] button.... ⑥
6. After the specified inspection time has elapsed, the wafer is placed on the macro table and rotated counterclockwise about 20 degrees, and the loader then proceeds to the 2nd Back Macro inspection.
 * Press the [Start] button if the [Inspection Time] control is set to [∞].
7. After the specified inspection time has elapsed, the wafer is unloaded into the cassette, and the second wafer is transferred to the Back Macro inspection position.
 Subsequent wafers are transferred automatically and sequentially.
8. After the last wafer is unloaded into the cassette, the operating units return to their initial positions and the loader stops.
9. Replace the cassette with the next one, and repeat the procedure from step 1.

3-2-5 Top Macro Inspection + Microscope Inspection

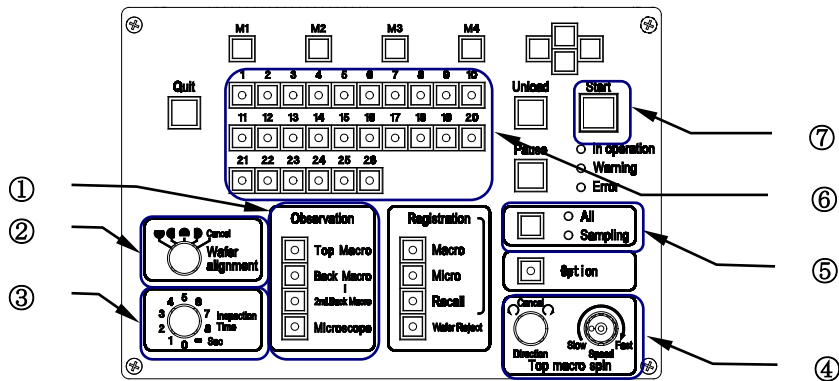

1. Set a cassette to the cassette table.
 2. Select the [Top Macro] and [Microscope] Observation buttons.....①
When the buttons are selected, the LEDs in the buttons light up.
If the [Top Macro] and [Microscope] LEDs are not lit, press the buttons to turn on the LEDs. If LEDs for other types of inspection are lit, turn them off by pressing their buttons.
 3. Set and confirm the detailed settings for inspection.
 - 1) [Wafer alignment]: Indicates the orientation flat/notch positions on the stage.....②
 - 2) [Inspection Time]: Enables the setting of Macro inspection time.③
 - 3) [Top Macro spin direction]: Enables the setting of wafer rotation direction during Top Macro inspection.④
 - 4) [Top Macro spin speed]: Enables the setting of wafer rotation speed during Top Macro inspection.④
 4. Set and confirm the inspection mode.
Select All or Sampling (P1 to P10).....⑤
Set the inspection wafer number(s) as needed.⑥
 5. Press the [Start] button to transfer the first wafer to the Top Macro inspection position.⑦
Top Macro Inspection is started.
 6. After the specified inspection time has elapsed, the macro table is lowered and the first wafer is transferred onto the vacuum stage.
After the first wafer is transferred onto the vacuum stage, the second wafer is transferred to the Top Macro inspection position, and the Top Macro inspection of the second wafer is started. After the specified inspection time has elapsed for the Top Macro inspection of the second wafer, the macro table is lowered for the next wafer.
- * Press the [Start] button if the [Inspection Time] control is set to [∞].
- * Wafers are not transferred onto the microscope if the stage is not in the wafer transfer position at the time of wafer transfer.

-
- * By setting the vacuum stage to the wafer transfer position during Top Macro inspection, Top Macro observation is terminated before the inspection time is completed. Microscope inspection is given preference and the wafer is transferred onto the vacuum table.
 - * If Microscope inspection is not required, press the [Unload] button. The first wafer is unloaded into the cassette and the second wafer is transferred to the Top Macro inspection position.
7. Subsequent wafers are transferred automatically and sequentially.
 8. After the last wafer is unloaded into the cassette, the operating units return to their initial positions and the loader stops.
 9. Replace the cassette with the next one, and repeat the procedure from step 1.

3-2-6 Back Macro Inspection + Microscope Inspection

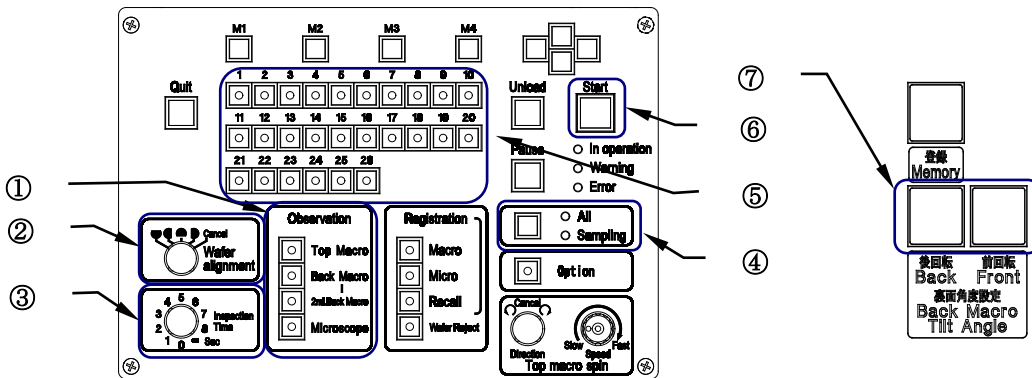

1. Set a cassette on the cassette table.
 2. Select the [Back Macro] and [Microscope] Observation buttons.①
When the buttons are selected, the LEDs in the buttons light up.
If the [Back Macro] and [Microscope] LEDs are not lit, press the buttons to turn on the LEDs. If LEDs for other types of inspection are lit, turn them off by pressing their buttons.
 3. Set and confirm the detailed settings for inspection.
 - 1) [Wafer alignment]: Indicates the notch positions on the stage.....②
 - 2) [Inspection Time]: Enables the setting of Macro inspection time.③
 4. Set and confirm the inspection mode.
Select All or Sampling (P1 to P10).....④
Set the inspection wafer number(s) as needed.⑤
 5. Press the [Start] button to transfer the first wafer to the Back Macro inspection position.....⑥
You can change the wafer tilt position (angle) for observation using the [Back Macro Tilt Angle] button. ...⑦
 6. After the specified inspection time has elapsed, the Back Macro inspection is completed, and the first wafer is transferred onto the vacuum stage.
After the first wafer is transferred onto the vacuum stage, the second wafer is transferred to the macro table position, and the loader starts Back Macro inspection of the second wafer. After the specified inspection time has elapsed for the Back Macro inspection of the second wafer, the L-arm is lowered for the next wafer.
- * Press the [Start] button if the [Inspection Time] control is set to [∞].
 - * Wafers are not transferred onto the microscope if the stage is not in the wafer transfer position at the time of wafer transfer.
 - * By setting the vacuum stage to the wafer transfer position during Back Macro inspection, the Back Macro inspection is terminated before the inspection time is completed. Microscope inspection is given preference and the wafer is transferred onto the vacuum table.

-
- * If Microscope inspection is not required, press the [Unload] button. The first wafer is unloaded into the cassette and the second wafer is transferred to the Back Macro inspection position.

 - 7. Subsequent wafers are transferred automatically and sequentially.
 - 8. After the last wafer is unloaded into the cassette, the operating units return to their initial positions and the loader stops.
 - 9. Replace the cassette with the next one, and repeat the procedure from step 1.

 - * If [2nd Back Macro] is selected for the inspection sequence, refer to **[3-2-4 Back Macro Inspection + 2nd Back Macro Inspection]**.

3-2-7 Top Macro Inspection + Back Macro Inspection

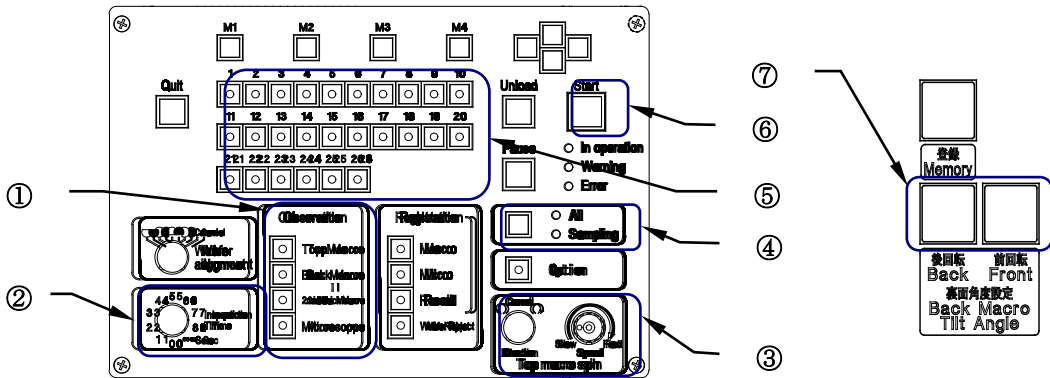

1. Set a cassette on the cassette table.
2. Select the [Top Macro] and [Back Macro] Observation buttons.①
 When the buttons are selected, the LEDs in the buttons light up.
 If the [Top Macro] and [Back Macro] LEDs are not lit, press the buttons to turn on the LEDs. If LEDs for other types of inspection are lit, turn them off by pressing their buttons.
3. Confirm the detailed settings for inspection.
 - 1) [Inspection Time]: Enables the setting of Macro inspection time. ②
 * The inspection time is common to the Top Macro, Back Macro and 2nd Back Macro inspections.
 - 2) [Top Macro spin direction]: Enables the setting of wafer rotation direction during the Top Macro inspection. ③
 - 3) [Top Macro spin speed]: Enables the setting of wafer rotation speed during the Top Macro inspection. ③
4. Set and confirm the inspection mode.
 Select All or Sampling (P1 to P10).④
 Set the inspection wafer number(s) as needed.⑤
5. Press the [Start] button to transfer the first wafer is transferred to the Top Macro inspection position.⑥
6. After the specified inspection time has elapsed, the macro table is lowered and the loader proceeds to Back Macro inspection.
 You can change the wafer tilt position (angle) for observation using the [Back Macro Tilt Angle] button. ...⑦
 * Press the [Start] button if the [Inspection Time] control is set to [∞].
7. After the specified inspection time has elapsed, the wafer is unloaded into the cassette, and the second wafer is transferred to the Top Macro inspection position.
 Subsequent wafers are transferred automatically and sequentially.
8. After the last wafer is unloaded into the cassette, the operating units return to their initial positions and the loader stops.
9. Replace the cassette with the next one, and repeat the procedure from step 1.

If [2nd Back Macro] is selected for the inspection sequence, refer to [3-2-4 Back Macro Inspection + 2nd Back Macro Inspection].

3-2-8 Microscope Inspection + Top Macro Inspection + Back Macro Inspection + 2nd Back Macro Inspection

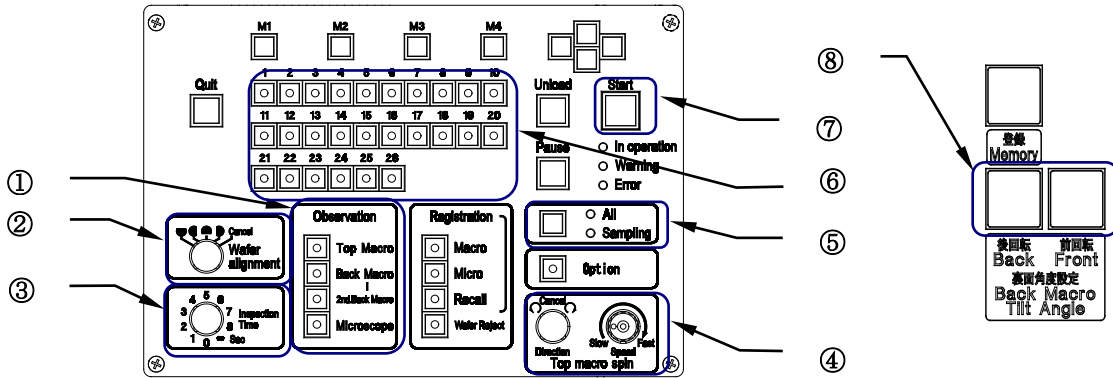

1. Set a cassette on the cassette table.
2. Select the [Top Macro], [Back Macro], [2nd Back Macro] and [Microscope] Observation buttons. All the Observation buttons are normally turned on (the LEDs are lit) when the power is turned on..... ①
If any of the [Top Macro], [Back Macro], [2nd Back Macro] and [Microscope] LEDs are not lit, press the buttons to turn on the LEDs.
* [2nd Back Macro] can be selected only when [Back Macro] is selected.
3. Set and confirm the detailed settings for inspection.
 - 1) [Wafer alignment]: Indicates the specified notch positions on the stage. ②
 - 2) [Inspection Time]: Enables the setting of Macro inspection time. ③
 - 3) [Top Macro spin direction]: Enables the setting of wafer rotation direction during Top Macro inspection. ④
 - 4) [Top Macro spin speed]: Enables the setting of wafer rotation speed during Top Macro inspection..... ④
4. Set and confirm the inspection mode.
Select All or Sampling (P1 to P10). ⑤
Set the inspection wafer number(s) as needed..... ⑥
5. Press the [Start] button, and the first wafer is transferred to the Top Macro inspection position. ⑦
The loader begins Top Macro inspection.
6. After the specified inspection time has elapsed, the macro table is lowered and the loader proceeds to Back Macro inspection.
You can change the wafer tilt position (angle) for observation using the [Back Macro Tilt Angle] button.... ⑧
* Press the [Start] button if the [Inspection Time] control is set to [∞].
7. After the specified inspection time has elapsed, Back Macro inspection is completed and the first wafer is transferred onto the vacuum stage.
8. After the first wafer is transferred onto the vacuum stage, the second wafer is transferred to the Top Macro inspection position, and the loader starts the Top Macro inspection of the second wafer.



9. After the specified inspection time has elapsed for the Top Macro inspection of the second wafer, the macro table is lowered and the loader starts the Back Macro inspection of the second wafer.
 10. After the specified inspection time has elapsed for the Back Macro inspection of the second wafer, the L-arm is lowered. The wafer is placed on the macro table and rotated counterclockwise about 20 degrees, and then the loader proceeds to the 2nd Back Macro inspection.
 11. After the specified inspection time has elapsed for the 2nd Back Macro inspection of the second wafer, the L-arm is lowered, waiting for the next wafer.
-
- * Press the [Start] button if the [Inspection Time] control is set to [∞].
 - * Wafers are not transferred onto the microscope if the stage is not in the wafer transfer position at the time of wafer transfer.
 - * By setting the vacuum stage to the wafer transfer position during Top Macro or Back Macro inspection, the Macro inspection is terminated before the inspection time is completed. Microscope inspection is given preference and the wafer is transferred onto the vacuum table.
 - * If the Microscope inspection is not required, press the [Unload] button. The first wafer is unloaded into the cassette and the second wafer is transferred to the Top Macro inspection position.
 - * If [2nd Back Macro] is selected for the inspection sequence, refer to **[3-2-4 Back Macro Inspection + 2nd Back Macro Inspection]**.

3-3 Special Operations

3-3-1 Changing the Wafer Selection Setting

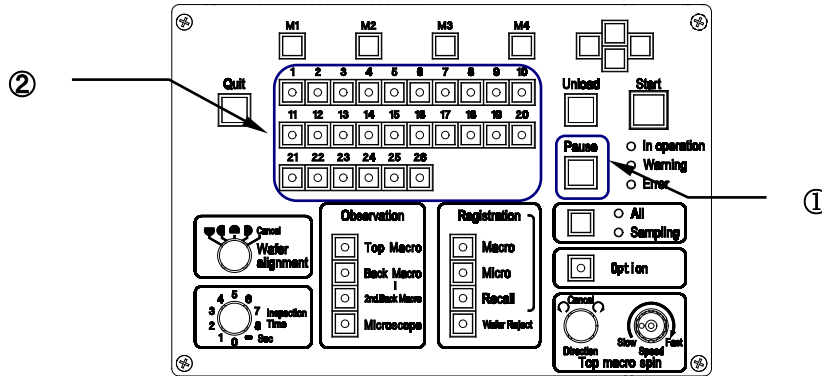

1. You can change the inspection wafer number settings after inspection has started.
2. The wafer numbers can be changed when the [Pause] button is pressed, or while the wafers wait for a start command input when the inspection time is set to ∞. (You can change the setting when the LED in the [Pause] button is blinking.)
3. Select the wafer numbers using the Wafer No. selector buttons.
4. Press the [Start] button, and the wafers are transferred with the new wafer selection settings.
5. The original wafer selection settings are restored after the entire operation of the specified cassette has finished.
 - Settings can not be changed for the wafer being inspected, indicated by a blinking LED in the Wafer No. selector button.
 - When wafers that have been inspected are re-specified in the specification change process, the re-specified wafers are inspected again after inspecting the wafers that have been specified prior to the specification changes.



This page intentionally left blank.

4 Specifications

Item	AL120-LMB12-F	AL120-LMB12-LP3
1. Transferable Wafer Size		
Applicable SEMI standard	SEMI M1.15-0600 Standard for 300mm Polished Mono-crystalline Silicon Wafers (Notched)	
Applicable wafer diameter	300 ± 0.2 mm	
Applicable wafer thickness	t = 775 ± 25 μm	
Applicable wafer warpage	0.1 mm or less	
Applicable wafer material	Silicon	
Applicable positioning shape	Notch depth :1.00 mm +0.25 mm, -0 mm,	
2. Settable Cassette		
Applicable cassette	FOSB (Front Opening Shipping Box) Shin-Etsu MW300G SEMI:M31-0999 standard *If you use other cassettes, contact EVIDENT.	:FOUP (Front Opening Unified Pods) Shin-Etsu FOUP300EX SEMI: E47.1-0200 standard :FOSB (Front Opening Shipping Box) Shin-Etsu MW300G SEMI:M31-0999 standard :FIMS-FOSB Miraial WINW300F *If you use other cassettes, contact EVIDENT.
Number of settable cassettes	1 cassette (for both loading and unloading)	
3. Macro Inspections		
Top Macro inspection	Tilt drive type: Joystick direct drive	
	Tilt angle: 20 degrees (max.)	
	Wafer rotation direction: Clockwise, counterclockwise, and non-rotating	
	Wafer rotation speed: 3 to 30 seconds/rotation (continuously variable)	
Back Macro inspection	Tilt drive type: Motorized drive	
	Tilt angle: 360 degrees from horizon (stepless) Angle can be changed during inspection. Equipped with the wafer edge holding mechanism	
	After the Back Macro inspection, the wafer is rotated counterclockwise about 20 degrees and inspected again.	
Inspection time setting	From 0 to 8 seconds and ∞ The ∞ setting maintains the inspection state. Time can be set in 1 second steps.	
	Common time setting for the Top Macro and Back Macro inspections	
4. Microscope Inspection		
Applicable microscope	EVIDENT MX61L/ MX63L	
Applicable microscope stage	AL120-VS12	
Microscopic observation method	Reflected light observation only	
Stage operation method	Manually-operated stage with XY coarse and fine adjustment and a 360-degree rotation mechanism (with an X-direction coarse travel clutch)	
Stage driving method	Belt drive	



Item	AL120-LMB12-F	AL120-LMB12-LP3
Microscopic observation range	φ300 mm	
Stage height stroke	Up and down from observation position by 1 mm	
Standard inspection magnification	Up to 50X objective	
Wafer table	Conductive PEEK resin	
Wafer holding method	Vacuum adsorption (Vacuum supplied by the loader)	
Stage Weight	Approx. 12 kg	
Anti-Vibration table	Spring-type vibration isolator	
5. Inspection Mode		
All (100%) inspection	Continuous transfer (Two wafers at a time are transferred)	
Sampling transfer patterns	10 patterns (P1 to P10) can be registered. Transfer of specified wafers (Two wafers at a time are transferred) (When one wafer is being inspected under the microscope, the next wafer is being transferred to the macro table position.)	
Sampling inspection patterns	10 patterns (L1 to L10) can be registered. Transfer and inspection of specified wafers (One wafer is transferred at a time)	
Automatic skip function	Slots with no wafer are automatically skipped in both the All and Sampling modes.	
6. Auxiliary Functions during Inspection		
Wafer registration	Numbers of defective wafers registered in each type of inspection can be displayed	
Pause	When the inspection time is set to 0 - 8 seconds, it can be extended by pausing the loader.	
Wafer removal	Wafers can be removed by using tweezers or similar tools during inspection.	
Wafer alignment(Notched)	Contactless detection using the opto-sensor Four notched positions (the near, far, right and left sides) can be selected on the microscope stage at 90-degree intervals. Settings can be changed during inspection. (The position specified before the notched alignment is effective.)	
Wafer alignment	Contactless alignment (optical)	
7. Protective Functions		
Emergency stop	EMO switch (primary power shut down turns off the main power of the system. When EMO switch is released , the main power stays turned off)	
Wafer popping	Wafers popping out of a cassette can be detected.	
Warnings and error display	The liquid crystal panel shows error codes and their details. An error log can be displayed and obtained.	
Wafers in the cassette	Any slanted wafers can be detected (1st-slot cross).	
Stage lock	The stage position can be locked until the wafer is transferred onto the microscope completely	
Wafer protection in case of power failure	Wafers are held in case of power failure.	
8. Transfer Mechanism		
Wafer transfer method	Wafer back side vacuum adsorption and mechanical arm transfer	
Wafer contact area material	Back side of wafer : PEEK (polyetheretherketone) resin Edge of wafer : polyacetal resin (Back macro inspection)	
Wafer contact area	Back side of wafer, Edge of wafer (when inspecting the back side)	
Noise level during transfer	69 dB(A) or lower	



Item	AL120-LMB12-F	AL120-LMB12-LP3
9. Cassette setting		
Installation height	900mm±10mm	
Cassette positioning	KINEMATIC COUPLING USED system to SEMI E57-0600	
Cassette clamp	Nothing	Automatic
Cassette door Opening and closing	Nothing (manual)	Automatic *hand-open type FOSB can be mounted by opening its lid.
10. Loader Utilities		
Loader power supply voltage	AC100 to 120 V ± 10%, 3.0 A AC220 to 240 V ± 10%, 1.7 A	
Power supply frequency	50/60 Hz ± 5 Hz	
Circuit breaker capacity	3.0 A	
Vacuum	-67 to -80 kPa	
Vacuum discharge	40 Liter/min. or more (including vacuum supply for the stage)	
Vacuum connection tube	1/4-inch soft polyurethane tube with insert pipe joint	
Clean dry air pressure	N/A	0.5MPa to 0.6MPa
Clean dry air flow	N/A	43 liter / min. or more (for load port)
Clean dry air connection tube	N/A	1/4-inch soft polyurethane tube with insert pipe joint
11. Operating Environment		
Place of use	Indoor use (in a clean room)	
Altitude	1000 m or lower	
Temperature	15 to 28°C (Storage and transport temperature: 0 to 40°C)	
Humidity	45 to 75% (Storage and transport humidity: 35 to 85%)	
Voltage fluctuation	±10%	
Pollution degree	2 (IEC60664)	
Installation category (Overvoltage category)	II (IEC60664)	
12. Dimensions and Weight		
Loader dimensions	1508 (W) × 1284 (D) × 1383 (H) mm *does not include protorusion	1508 (W) × 1390 (D) × 1383 (H) mm *does not include protorusion
Weight	Approx. 270 kg	Approx. 360 kg



This page intentionally left blank.

5 Problems during Use and Solutions

5-1 When Warning Codes Are Displayed

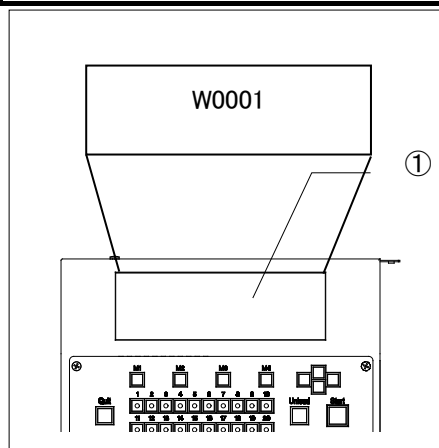

While not a malfunction, if the loader determines that there is the possibility that normal wafer loading operations will be hindered, it issues a warning code on the liquid crystal panel ①, and halts operations.

In this event, take appropriate countermeasures listed below in **the Warning Codes** before pressing the [Start] button again. The loader will return to normal operation if the problem has been solved correctly.

Warning Codes

Warning Code No.	Causes and Solutions	
W0001	Cause	<ul style="list-style-type: none"> The cassette has not been set in the correct position.
	Solution	<ul style="list-style-type: none"> Reset the cassette in the correct position and press the [Start] button.
W0002	Cause	<ul style="list-style-type: none"> The stage has not been set in the correct position. The vacuum stage is not set after the inspection time has elapsed.
	Solution	<ul style="list-style-type: none"> Reset the stage properly to the wafer transfer position. [Note] Do not move the stage until the F-arm completes its up-and-down movement. Make sure that the stage operation permission LED is lit before moving the stage.
W0003	Cause	<ul style="list-style-type: none"> The observation window is open when the inspection time is over.
	Solution	<ul style="list-style-type: none"> Close the observation window and press the [Start] button to recover. [Note] When the macro inspection finishes close the macro observation window.
W0004	Cause	<ul style="list-style-type: none"> The foreign object (wafer) is detected on the A-arm during initialization. The wafer is detected as a foreign object due to vacuum pressure being too high.
	Solution	<ul style="list-style-type: none"> Remove the wafer or set the vacuum pressure within the specifications, and then press the [Start] button. [Note] To unload the wafer automatically, refer to 5-6 Automatic Unloading.
W0005	Cause	<ul style="list-style-type: none"> The foreign object (wafer) is detected on the F-arm (macro table side) during initialization. The wafer is detected as a foreign object due to vacuum pressure being too high.
	Solution	<ul style="list-style-type: none"> Remove the wafer or set the vacuum pressure within the specifications, and then press the [Start] button. [Note] To unload the wafer automatically, refer to 5-6 Automatic Unloading.
W0006	Cause	<ul style="list-style-type: none"> The foreign object (wafer) is detected on the F-arm (stage side) and on the stage table during initialization. The wafer is detected as a foreign object due to vacuum pressure being too high.
	Solution	<ul style="list-style-type: none"> Remove the wafer or set the vacuum pressure within the specifications, and then press the [Start] button. [Note] To unload the wafer automatically, refer to 5-6 Automatic Unloading.



Warning Code No.	Causes and Solutions	
W0007	Cause	<ul style="list-style-type: none"> The foreign object (wafer) is detected on the macro table during initialization. The wafer is detected as a foreign object due to vacuum pressure being too high.
	Solution	<ul style="list-style-type: none"> Remove the wafer or set the vacuum pressure within the specifications, and then press the [Start] button. [Note] To unload the wafer automatically, refer to 5-6 Automatic Unloading.
W0008	Cause	<ul style="list-style-type: none"> The foreign object (wafer) is detected on the back macro arm during initialization. The wafer is detected as a foreign object due to vacuum pressure being too high
	Solution	<ul style="list-style-type: none"> Remove the wafer or set the vacuum pressure within the specifications, and then press the [Start] button. [Note] To unload the wafer automatically, refer to 5-6 Automatic Unloading.
W0009	Cause	<ul style="list-style-type: none"> The foreign object (wafer) is detected on the stage table during initialization. The wafer is detected as a foreign object due to vacuum pressure being too high.
	Solution	<ul style="list-style-type: none"> Remove the wafer or set the vacuum pressure within the specifications, and then press the [Start] button. [Note] To unload the wafer automatically, refer to 5-6 Automatic Unloading.
W0010	Cause	<ul style="list-style-type: none"> The specified slot already contains wafers
	Solution	<ul style="list-style-type: none"> Remove the wafers and press the [Start] button, or specify another slot to unload wafers.
W0011	Cause	<ul style="list-style-type: none"> The size of the specified wafer and the wafer to be transferred do not match
	Solution	<ul style="list-style-type: none"> Remove the wafers and press the [Start] button, or set correct wafer size.
W0012	Cause	<ul style="list-style-type: none"> A wafer is improperly inserted into a slot inside a cassette; it is inserted diagonally.
	Solution	<ul style="list-style-type: none"> Insert the wafer by taking care that both edges of the wafer are in the same slot, and press the [Start] button.
W0013	Cause	<ul style="list-style-type: none"> The thickness of a wafer is different from the standard thickness value.
	Solution	<ul style="list-style-type: none"> Check to see if two wafers are inserted into the same slot or if the type of the wafer to be inspected is different from the selected wafer type. If two wafers are in the same slot, remove one and press the [Start] button. If the selected wafer type is wrong, press the [Exit] button and redo the wafer type selection process.
W0014	Cause	<ul style="list-style-type: none"> A wafer protrudes from a cassette.
	Solution	<ul style="list-style-type: none"> Insert the wafer fully into the cassette and press the [Start] button.

NOTICE

If the loader is used at a low pressure (-53 KPa or lower) and with sudden changes in the vacuum pressure, the loader may be unable to detect any wafers remaining in the transfer path and may cause damage to the wafer(s).

If automatic unloading is performed in this state, the loader can not detect any remaining wafers and may cause damage to them. Remove the wafer using tweezers or similar tools and ensure that the cause is dealt with.

Automatic unloading may be unable to work. In this case, remove the wafer using tweezers or similar tools and check the vacuum pressure before discharging again.

Ensure proper vacuum pressure and discharge when using the loader.



5-2 When Error Codes Are Displayed

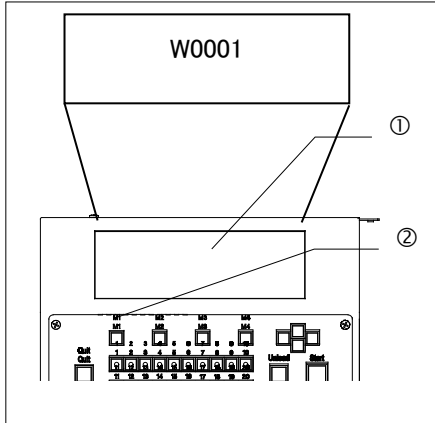

When an error occurs, the loader detects the error and stops all operations. At the same time, a blinking error code appears on the liquid crystal panel ① and a buzzer sounds.

Press the [M1] menu button ② to silence the buzzer.

When there are no wafers in the transfer path, turn the main switch OFF and then turn it back to ON.

When there are wafers in the transfer path, turn the main switch OFF, remove the wafer(s) using tweezers or similar tools, and ensure that the cause is dealt with.

NOTICE

When an adsorption error has occurred, the loader may be unable to hold wafers securely. Take care not to perform automatic unloading without dealing with the cause. Wafers may be damaged.

If any similar errors occur during operation, please contact the EVIDENT distributor for your loader.

Please give the distributor the following information:

Product name:
 Serial No.:
 Error code:
 Phenomenon:



Error Codes

1. FOSB Table Unit Wafer Mapping Sensor Vertical Movement Control Error
 * AL120-LMB12-F

Error No.	Error Status	Note
E0601	The motor stepout is detected during operation.	U105,U106
E0602	Origin sensor cannot be detected within the set time during initialization.	U104
E0603	The motor driver is over-heated.	

2. FOSB Table Unit Wafer Mapping Sensor Horizontal Movement Control Error
 *AL120-LMB12-F

Error No.	Error Status	Note
E0604	Multiple sensors is detected simultaneously	U101,U102,U103
E0605	None of the positioning sensor can be detected	U101,U102,U103
E0606	Origin sensor cannot be detected within the set time during initialization.	U101
E0607	Limit sensor cannot be detected within set time	U102
E0608	Positioning sensor cannot be detected during rotation sensor detection	U103

3. FOUP OPENER Movement Control Error
 * AL120-LMB12-LP3 (for FOUP)

With the error code indication to an operation panel, the error LED of the FOUP opener flashes on and off.

Error No.	Error Status
E1501	FOUP clamp action error Clamp action cannot be completed within set time
E1511	FOUP unclamp action error Clamp cannot be released within set time
E1512	FOUP dock action error Dock action cannot be completed within set time
E1513	FOUP undock action error Dock cannot be released within the set time
E1514	FOUP latch action time out error Dock action cannot be completed within set time
E1515	FOUP unlatch action error Dock action cannot be completed within set time
E1516	FOUP door vacuum error FOUP door vacuum cannot be completed within the set time
E1517	FOUP door vacuum release error FOUP door vacuum cannot be released within the set time
E1518	FOUP door open action error FOUP door cannot be opened within the set time
E1519	FOUP door close action error



Error No.	Error Status
	FOUP door cannot be closed within the set time
E151A	Mapping sensor action error Sensor cannot be completed within the set time
E151B	Mapping sensor return action error Sensor cannot be returned within the set time
E1520	Initialize (origin return action) error Initialize cannot be completed within the set time
E1521	Load error Load action is not completed within the set time
E1522	Unload error Unload action is not completed within the set time
E1523	Z (up and down) axis positioning action error Positioning action cannot be completed within the set time
E1524	Mapping sensor error Sensor is already ON before start mapping
E1540	Mapping error Wafer detect sensor ON count and OFF count do not match
E1541	Mode status error Mode is changed during the action
E1570	Clamp status detecting sensor error Both clamp and unclamp sensors are ON simultaneously.
E1571	Dock status detect sensor error Both dock and undock sensors are ON simultaneously.
E1572	Latch status detect sensor error Both latch and unlatch sensors are ON simultaneously.
E1573	Door open close status detect sensor error Both door open and door closed sensors are ON simultaneously.
E1574	Mapping sensor position status detect sensor error Both mapping start and mapping return sensors are ON simultaneously.
E15A0	FOUP door retention error Sucking is released at the door retention status
E15A1	Wafer protrude error Sticking wafer is detected before wafer vertical action started
E15A2	FOUP cassette setting error (loading sensor) Cassette is not placed properly
E15A3	FOUP cassette loading error (load presence sensor) Cassette is not placed properly
E15A5	A drop in the clean dry air pressure was detected
E15B0	Interlock error Interlock signal from the upper stream system is not inputted
E15C0	System parameter error Parameter is changed
E15D0	Unit position mapping sensor error Sensor is already ON before start mapping

Error No.	Error Status
E15E0	Exhaust fan action error Exhaust fan action is at the stop status
E15E2	Z axis encoder error Absolute data of vertical axis servo driver is improper
E15E3	Z axis servo driver alarm Alarm of the vertical axis servo driver generates
E15E4	Z axis over run error Vertical axis is at the over run area
E15FE	Dock action foreign substance error Foreign substance is detected between door and FOUP during dock action
E15FF	FOUP cassette setting error (Vertical action detect sensor) Cassette is not properly set
E1590	Keep alarming
E1591	Communication error Communication error between FOUP opener and sub CPU
E1592	FOUP opener action mode error FOUP action mode (routine/maintenance) setting is not correct
E1593	Motion error Internal motion is not correct
E1594	Cassette presence error Cassette reading error
E1595	Clamp error Clamp position is not correct
E1596	Door clamp error Door clamp position is not correct
E1597	Door vacuum error Door vacuum status is not correct
E1598	Door position error Door position is not correct
E1599	Wafer protrude sensor error Sensor detects wafer protrudes
E159A	Z axis position error Z axis (vertical) position is not correct
E159B	Y axis position error Y axis (back and forth) position is not correct
E159C	Map error Mapper is not in correct position
E159D	Action time out error Action cannot completed within the set time
E159E	Wafer position, thickness error Wafer position, thickness is not correct



Error No.	Error Status
E159F	Mapping error

4. Window lock action control Error

Error No.	Error Status	Note
E1201	Both lock and release sensors are detected simultaneously	U702,U703
E1202	Lock cannot be made within the set time	U702
E1203	Lock release cannot be made within the set time	U703

5. A-arm Vertical Movement/Vacuum Control Error

Error No.	Error Status	Note
E0101	Detected vertical drive motor step-out	U204,U214
E0102	Multiple sensors are detected simultaneously	U201, U202,U203
E0103	The middle point sensor cannot be detected after moving to the middle point.	U202
E0104	Failed to detect at lower limit sensor after lowering action	U203
E0105	Do not move to the original position within the set time.	U203
E0106	Motion did not completed within the set time	
E0107	Cannot detect vacuum confirmation within set time	U002
E0108	Cannot detect vacuum release within the set time	U002
E0109	Not in a specified position when the operation starts	
E0110	Specified the operation to the impossible position	
E0111	Not in a position where it can be initialized	
E0112	The motor driver is over-heated.	

6. A-arm Horizontal Movement Control Error

Error No.	Error Status	Note
E0201	Both of the upper-/lower-end sensors is detected.	U205,U207
E0202	The A-arm position is specified exceeding the motion range in the software.	
E0203	The A-arm is not at the specified position when it starts its movement.	U205,U206,U207
E0204	The unit cannot be initialized within the set time.	U207
E0205	The sensor cannot be detected after moving to the macro position.	U207
E0206	The sensor cannot be detected after moving to the front of the cassette position.	U206
E0207	The sensor cannot be detected after moving to the cassette position.	U205
E0208	A-arm's movement does not finish within the set time.	



E0209	Not in a position where it can be initialized	
E0210	The motor driver is over-heated.	

7. A-arm Horizontal Movement Control Error

Error No.	Error Status	Note
E0301	The unit cannot be initialized within the set time.	U208
E0302	The A-arm position is specified exceeding the motion range in the software.	
E0303	The origin sensor cannot detect the A-arm position during initialization.	U208
E0304	The forward/backward movement does not finish within the set time.	
E0305	The positioning sensor cannot detect the A-arm position at the end of its movement.	U208
E0306	Not in a specified position when the operation starts	U208

8. Notch Alignment/Centering/Macro Vertical Movement/Vacuum Control Error

Error No.	Error Status	Note
E0401	Both of the lower-end/upper- sensors is detected.	U402,U401
E0402	Upper- sensors does not go up within the set time	U401
E0403	Lower-end does not go down within the set time.	U402
E0404	Vacuum ON status cannot be detected within the set time.	U003
E0405	Vacuum OFF status cannot be detected within the set time.	U003
E0406	Notch cannot be detected within the set time.	
E0407	The rotational motor driver is over-heated.	
E0408	Not in a specified position when the operation starts	
E0409	The centering sensor cannot detect the wafer.	U209,U210
E0410	Shift of wafer exceed centering limit.	U209,U210

9. L-arm Vertical Movement/Vacuum Control Error

Error No.	Error Status	Note
E0801	Both of the lower-end/upper- sensor is detected.	U602,U603 U604
E0802	Neither of the lower-end/upper- sensors is detected.	U602,U603 U604
E0803	The L-arm is not at the specified position when it starts its movement.	U602,U604
E0804	Upper- sensors does not go up within the set time	U602
E0805	Transfer sensor does not go up within the set time	U603
E0806	Lower-end does not go down within the set time.	U604
E0807	Cannot detect vacuum confirmation within set time	U004
E0808	Cannot detect vacuum release within the set time	U004



10. L-arm Rotation Movement Control Error

Error No.	Error Status	Note
E0501	None of the origin and limit sensors detects any error.	U601
E0502	The unit cannot be initialized within the set time.	U601
E0503	The condition of the origin sensor does not change within the set time.	U601
E0504	Movement does not finish within the set time.	
E0505	The origin sensor cannot detect.	U601
E0506	Not in a position where it can be initialized	
E0507	The motor driver is over-heated.	

11. Stage Vacuum Control Error

Error No.	Error Status	Note
76	Vacuum ON status cannot be detected within the set time.	U001
77	Vacuum OFF status cannot be detected within the set time.	U001

12. F-arm Vertical Movement /Vacuum Control Error

Error No.	Error Status	Note
E1301	Both of the lower-end/upper- sensors is detected.	U501,U502, U503
E1302	The F-arm is not in a specified position when the operation starts.	
E1303	The upper limit sensor cannot be detected within set time.	U501
E1304	The transfer sensor cannot be detected within set time.	U502
E1305	The lower limit sensor cannot be detected within set time.	U503
E1306	The vacuum ON status of the F-1 arm cannot be detected within set time.	U005
E1307	The vacuum OFF status of the F-1 arm cannot be detected within set time.	U005
E1308	The vacuum ON status of the F-2 arm cannot be detected within set time.	U006
E1309	The vacuum OFF status of the F-2 arm cannot be detected within set time.	U006

13. F-arm Horizontal Movement /Vacuum Control Error

Error No.	Error Status	Note
E1401	Both of the lower-end/upper- sensors is detected.	U504
E1402	The stage side sensor cannot be detected within set time.	U507
E1403	The middle position sensor cannot be detected within set time.	U506
E1404	The macro side sensor cannot be detected within set time.	U505
E1405	The initialization in horizontal direction cannot be completed within set time.	U506
E1406	The motor driver is over-heated.	

14. Other Errors

Error No.	Error Status
E0001	The cassette has not been set in the correct position.
E0014	A wafer protrudes from a cassette.
E1001	Communication error between the main CPU and Sub CPU.
E1002	No stage sensor detection during the F-arm vertical movement.
E1003	CPU abnormality is detected.
E1004	Wafer exists at a impossible position while observation. *Vacuum pressure is loud, and there is a wafer in the stage. Adjust vacuum pressure to the specifications range.
E1006	The +24V power is not properly supplied.
E1007	Main pressure sensor error
E1008	Invalid slot number

5-3 How to Reset the Circuit Breaker

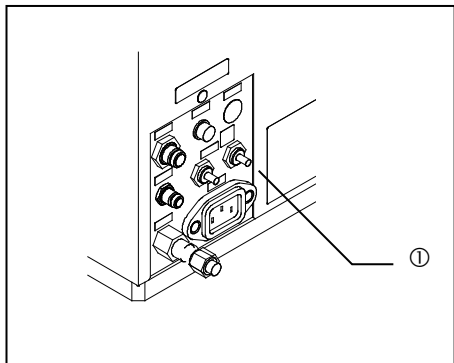

- 1) Turn the main switch OFF, disconnect the power cord on the back side of the loader, and press the reset button ① (protruding part) of the circuit breaker that has tripped.
- 2) After the circuit breaker switch returns to the normal position, connect the power cord to AC Line again.
- 3) Turn the main switch ON and check that the loader operates normally.



When the circuit breaker has tripped, disconnect the power cord immediately and remove the cause.

5-4 Emergency Off

By pressing the [EMERGENCY OFF] button the system can be powered off.

Make sure to check the Main switch is turned OFF before release the [EMERGENCY OFF] button.

In order to unlock the [EMERGENCY OFF] button rotate its knob to clockwise.

If there are any wafers in the transfer path, refer to section 5-6 Automatic Unloading.

5-5 Power Failure

Wafers on transfer arms remain held by the vacuum when the power supply is cut in events such as blackouts. If there are no wafers in the transfer path of the loader, turn the main switch OFF then turn it back ON.

If there are any wafers in the transfer path, turn the main switch OFF and refer to **5-6 Automatic Unloading**.

5-6 Automatic Unloading

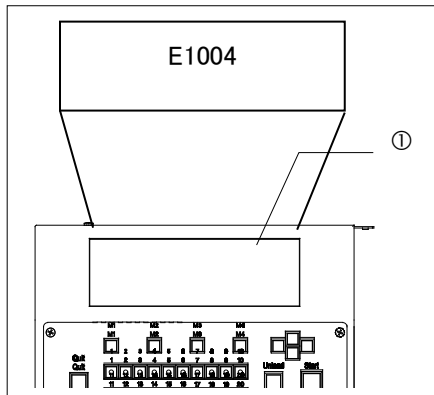

When the power is cut off with a wafer left in the transfer path in events such as an emergency halt, power failure, or occurrence of error, the wafer left in the transfer path can be unloaded automatically into the cassette following the procedure given below (5-6 1 to 4) or can be removed using tweezers.

If the wafer loader judges that wafers cannot be automatically unloaded, error No. E1004 (the position of the wafer is out of the allowable range) or No. E0111, E0209, E0506 is displayed on the liquid crystal panel ①.

In this case, turn the main switch OFF and unload the wafer into the cassette using tweezers or similar tools

NOTICE

- When using the automatic unloading procedure after a warning or error has occurred, remove the cause of the warning or error before attempting automatic unloading. If automatic unloading is done before the cause is removed, it may cause damage to the wafers. If the cause is unknown, unload the wafers into the cassette using tweezers or similar tools, and then turn on the loader.
- Make sure that there are no wafers in the specified slot before using the automatic unloading procedure.
- Your loader may have been set to skip initialization when the power is turned on. Press the [Start] button to initialize the loader, and then follow the automatic unloading procedure.
- When the wafer is removed using the tweezers or when the error code [E1004] appears, you can open the observation window. During automatic unloading, as the open/close lock mechanism of the observation window is enabled, you cannot open the observation window. Be careful, if you open the window forcibly, the window may be damaged.

1 During the Top Macro Inspection

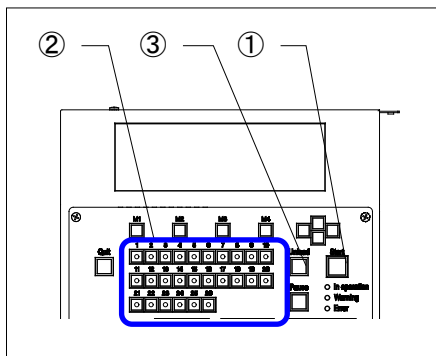

When the loader has stopped with a wafer held on the macro table, the vacuum remains on. Unload the wafer according to the following procedure.

1. If the main switch is turned ON, the loader will not operate but will indicate the warning code [W0007], still holding the wafer.
2. **Removing the wafer using tweezers:**
Press the [start] button ① to lower the macro table. The table is set horizontally and the wafer vacuum is canceled. Open the door and remove the wafer using tweezers, etc.
3. **Unloading the wafer automatically:**
Using the Wafer No. selector buttons, specify the number of the cassette slot to unload the wafer.
4. The LED in the specified Wafer No. selector button lights up.
5. Press the [Unload] button ③.
6. After wafer mapping is completed, the wafer is automatically unloaded into the specified slot.

2 During the Back Macro Inspection

When the loader has stopped with a wafer held on the L-arm, the vacuum remains on. Unload the wafer according to the following procedure.

1. If the main switch is turned ON, the loader will not operate but will indicate the warning code [W0008], still holding the wafer.
2. **Removing the wafer using tweezers:**
Press the [start] button ①. The wafer is transferred onto the macro table and the wafer vacuum is canceled. Open the door and remove the wafer using tweezers, etc.
3. **Unloading the wafer automatically:**
Using the Wafer No. selector buttons, specify the number of the cassette slot to unload the wafer.
4. The LED in the specified Wafer No. selector button lights up.
5. Press the [Unload] button.
6. After wafer mapping is completed, the wafer is automatically unloaded into the specified slot.

3 When a Wafer is on the F-arm

When the loader stops with a wafer held on the F-arm, the wafer on the F-arm is vacuumed. Unload the wafer according to the following procedures. If two wafers are held on the F-arm, unload the wafer that is on the macro table first.

1. Set the main button to ON. The loader does not operate, but the warning code [W0005] or [W0006] appears while the wafer is vacuumed.
2. **Removing the wafer using tweezers:**
Press the [start] button ①. The wafer vacuum is canceled. Open the door and remove the wafer using tweezers, etc.
3. **Unloading the wafer automatically:**
Using the Wafer No. selector buttons, specify the number of the cassette slot to unload the wafer.
4. The LED in the specified Wafer No. selector button lights up.
5. Press the [Unload] button.
6. After wafer mapping is completed, the wafer is automatically unloaded into the specified slot.
7. Repeat the procedure from step 2 to unload the remaining wafer.
Mapping has already been executed at this time. You can specify only a vacant slot (with the LED lit in the Wafer No. selector button).

4 When a Wafer is on the A-arm

When the loader has stopped with wafers held on the A-arm, the vacuum remains on. Unload the wafer according to the following procedure.

When two wafers are held on the A-arm, unload the wafer on the macro table first.

1. Set the main button to ON. The loader does not operate, but the warning code [W0004] appears while the wafer is vacuumed.
2. **Removing the wafer using tweezers:**
Press the [Start] button and remove a wafer from A-arm using tweezers.
3. **Unloading the wafer automatically:**
Using the Wafer No. selector buttons, specify the number of the cassette slot to unload the wafer.
4. The LED in the specified Wafer No. selector button lights up.

5. Press the [Unload] button.
6. After wafer mapping is completed, the wafer is automatically unloaded into the specified slot.

5 When a Wafer is on the Vacuum Stage

When the loader has stopped with a wafer held on the vacuum stage, the vacuum remains on. Unload the wafer according to the following procedure.

1. Set the vacuum stage to the transfer position.
2. Set the main button to ON. The loader does not operate, but the warning code [W0006] or [W0009] appears while the wafer is vacuumed.
3. **Removing the wafer using tweezers:**
Press the [start] button ①. The wafer vacuum is canceled. Open the door and remove the wafer using tweezers, etc.
4. **Unloading the wafer automatically:**
Using the Wafer No. selector buttons, specify the number of the cassette slot to unload the wafer.
5. The LED in the specified Wafer No. selector button lights up.
6. Press the [Unload] button.
7. After wafer mapping is completed, the wafer is automatically unloaded into the specified slot.

Manufactured by

EVIDENT CORPORATION

6666 Inatomi, Tatsuno-machi, Kamiina-gun, Nagano 399-0495, Japan

Distributed by

EVIDENT EUROPE GmbH

Caffamacherreihe 8-10, 20355 Hamburg, Germany

EVIDENT EUROPE GmbH UK Branch

Part 2nd Floor Part A, Endeavour House, Coopers End Road, Stansted CM24 1AL, U.K.

EVIDENT SCIENTIFIC, INC.

48 Woerd Ave Waltham, MA 02453, U.S.A.

EVIDENT AUSTRALIA PTY LTD

97 Waterloo Road, Macquarie Park, NSW 2113, Australia

Life science solutions

Service Center



[https://www.olympus-lifescience.com/
support/service/](https://www.olympus-lifescience.com/support/service/)

Official website



<https://www.olympus-lifescience.com>

Industrial solutions

Service Center



[https://www.olympus-ims.com/
service-and-support/service-centers/](https://www.olympus-ims.com/service-and-support/service-centers/)

Official website



<https://www.olympus-ims.com>