

INSTRUCTIONS

BX-RLAA

MOTORIZED REFLECTED LIGHT BRIGHTFIELD/DARKFIELD ILLUMINATOR

Optical Microscope Accessory

This instruction manual is for the Olympus Motorized Reflected Light Brightfield/Darkfield Illuminator Model BX-RLAA. The BX-RLAA is capable of brightfield and darkfield observations under the reflected light when it is installed on the BX61TRF system microscope frame. To ensure the safety, obtain optimum performance and to familiarize yourself fully with the use of this unit, we recommend that you study this manual thoroughly before operating the microscope. Retain this instruction manual in an easily accessible place near the work desk for future reference.



A X 7 6 2 3

This product is a part of the system product which complies with the CE marking.
Please refer to the instruction manual of your system product for the safety instructions related to the CE marking.



In accordance with European Directive on Waste Electrical and Electronic Equipment, this symbol indicates that the product must not be disposed of as unsorted municipal waste, but should be collected separately.
Refer to your local Olympus distributor in EU for return and/or collection systems available in your country.

For Korea only

B급 기기 (가정용 방송통신기자재)

이 기기는 가정용(B급) 전자파적합기기로서 주로 가정에서 사용하는 것을 목적으로 하며, 모든 지역에서 사용할 수 있습니다.

CONTENTS

Correct assembly and adjustments are critical for the microscope to exhibit its full performance. If you are going to assemble the microscope yourself, please read chapter 9, "ASSEMBLY" (pages 27 to 29) carefully.

IMPORTANT – Be sure to read this chapter for safe use of the equipment. –	1-2
1 SYSTEM DIAGRAM	3
2 NOMENCLATURE OF BX-RLAA	4
3 MOTORIZED REFLECTED LIGHT BRIGHTFIELD/DARKFIELD OBSERVATION PROCEDURE	5-6
4 USING THE CONTROLS OF BX-RLAA	7-11
1 Selecting the Observation Path 2 Centering the Field Iris Diaphragm (FS)	
3 Centering the Aperture Iris Diaphragm (AS)	
4 Using the Interlocked ND Filter 5 Using the Filters	
5 STAGE FOR METALLURGICAL SPECIMENS	12-14
1 Placing the Specimen 2 Using the Y-Axis Movement Lock Lever	
6 OBSERVATION METHODS (Using BX-RLAA)	15-20
6-1 Reflected Light Brightfield/Darkfield Observation	15
6-2 Reflected Light Nomarski DIC Observation	15-20
6-3 Reflected Light Simplified Polarized Light Observation	20
7 SPECIFICATIONS	21
8 OPTICAL CHARACTERISTICS «UIS2 Series»	22-26
9 ASSEMBLY	27-29

IMPORTANT

The BX-RLAA motorized reflected light brightfield/darkfield illuminator can be controlled electrically by the BX-UCB control box and U-HSTR2 hand switch (the BX-RLAA can also be interlocked with other motorized modules by running the BX2 software for PC).

Motorized features:

- BF (Brightfield)/DF (Darkfield) switching
- Aperture iris diaphragm opening/closing
- Equipped with a motorized revolving nosepiece connector

1

Getting Ready

1. This unit is a precision instrument including motorized parts. Handle it with care and avoid subjecting it to sudden or severe impact. Note that the motorized parts cannot be controlled manually.
2. Do not use this unit where it is subjected to direct sunlight, high temperature and humidity, dust or vibrations. (For the operating conditions, refer to chapter 7, "SPECIFICATIONS".)
3. The microscope with this unit can be used with only one intermediate attachment such as a U-CA magnification changer or U-EPA2 eyepoint adjuster.

2 Maintenance and Storage

1. To clean the lenses and other glass components, simply blow dirty away using a commercially available blower and wipe gently using a piece of cleaning paper (or clean gauze).
If a lens is stained with fingerprints or oil smudges, wipe it gauze slightly moistened with commercially available absolute alcohol.
▲ Since the absolute alcohol is highly flammable, it must be handled carefully.
Be sure to keep it away from open flames or potential sources of electrical sparks — for example, electrical equipment that is being switched on or off.
Also remember to always use it only in a well-ventilated room.
2. Do not attempt to use organic solvents to clean the components other than the glass components. To clean them, use a lint-free, soft cloth slightly moistened with a diluted neutral detergent.
3. Never attempt to disassemble any part of the microscope. Otherwise, malfunction or failure results.
4. When not using the microscope system, set the main switch to “○” (OFF), wait until the lamp housing has cooled down, and keep the microscope system covered with the a dust cover.
5. When disposing of this product, check the regulations and rules of your local government and be sure to observe them.

3 Caution

If this unit is used in a manner not specified by this manual, the safety of the user may be imperiled. In addition, the equipment may also be damaged. Always use the equipment as outlined in this instruction manual.

The following symbols are used to set off text in this instruction manual.

- ▲: Indicates that failure to follow the instructions in the warning could result in bodily harm to the user and/or damage to equipment (including objects in the vicinity of the equipment).
- ★: Indicates that failure to follow the instructions could result in damage to equipment.
- ◎: Indicates commentary (for ease of operation and maintenance).

1 SYSTEM DIAGRAM

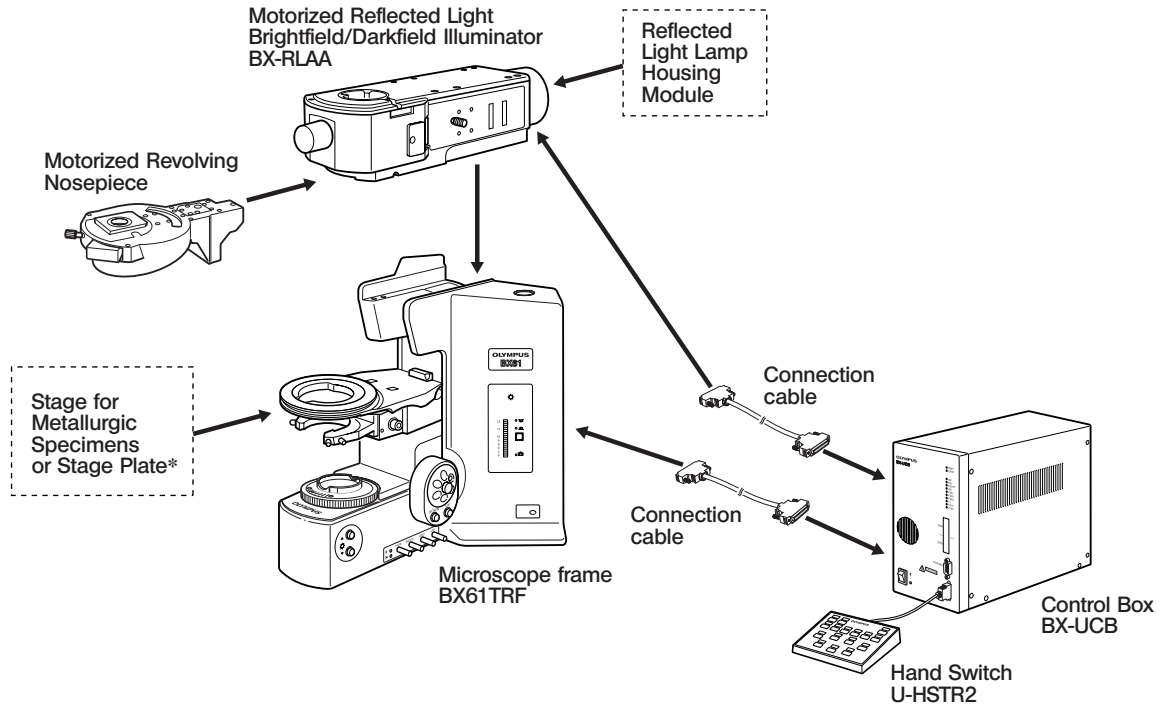

*To improve the ease of use of the stage, replace it with a stage for metallurgic specimens or replace the specimen holder with a stage plate.

2 NOMENCLATURE OF BX-RLAA

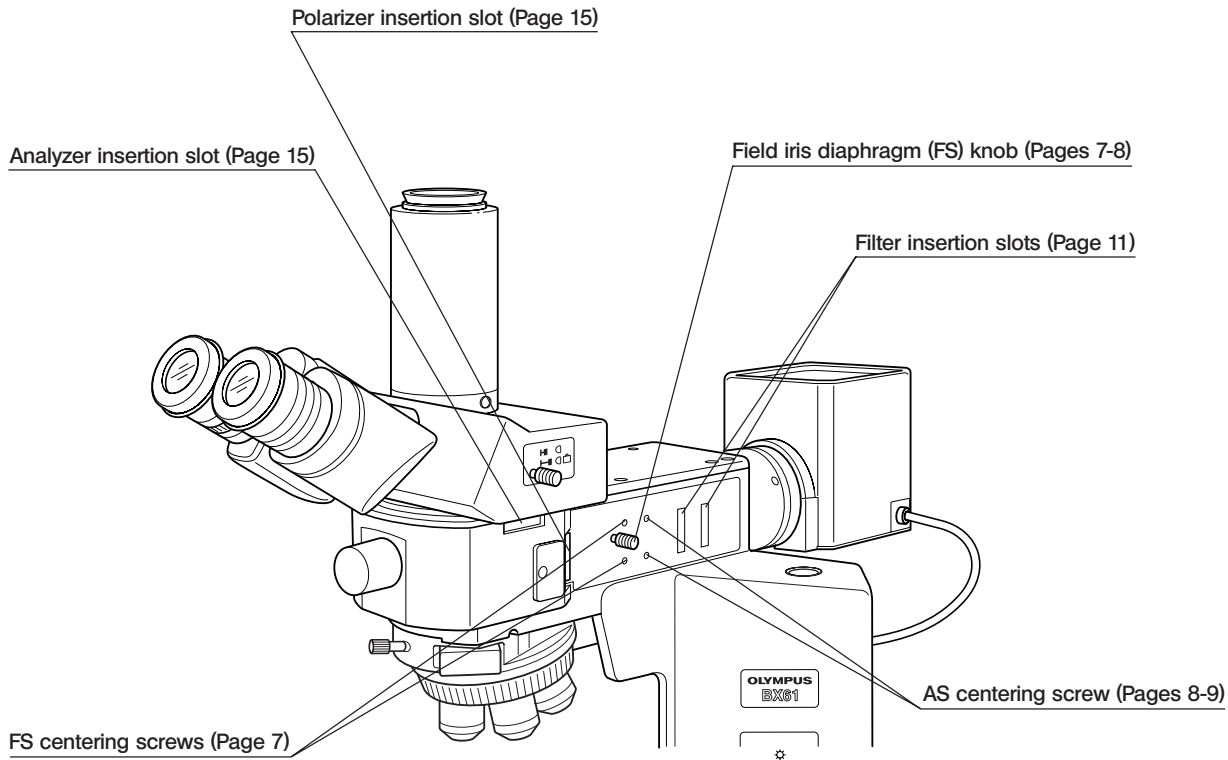

3

MOTORIZED REFLECTED LIGHT BRIGHTFIELD/DARKFIELD OBSERVATION PROCEDURE

©The following flow shows the basic operating procedure for reflected light brightfield or darkfield observation. The operating procedures for polarized light and Nomarski DC observations will be described separately in their descriptions.

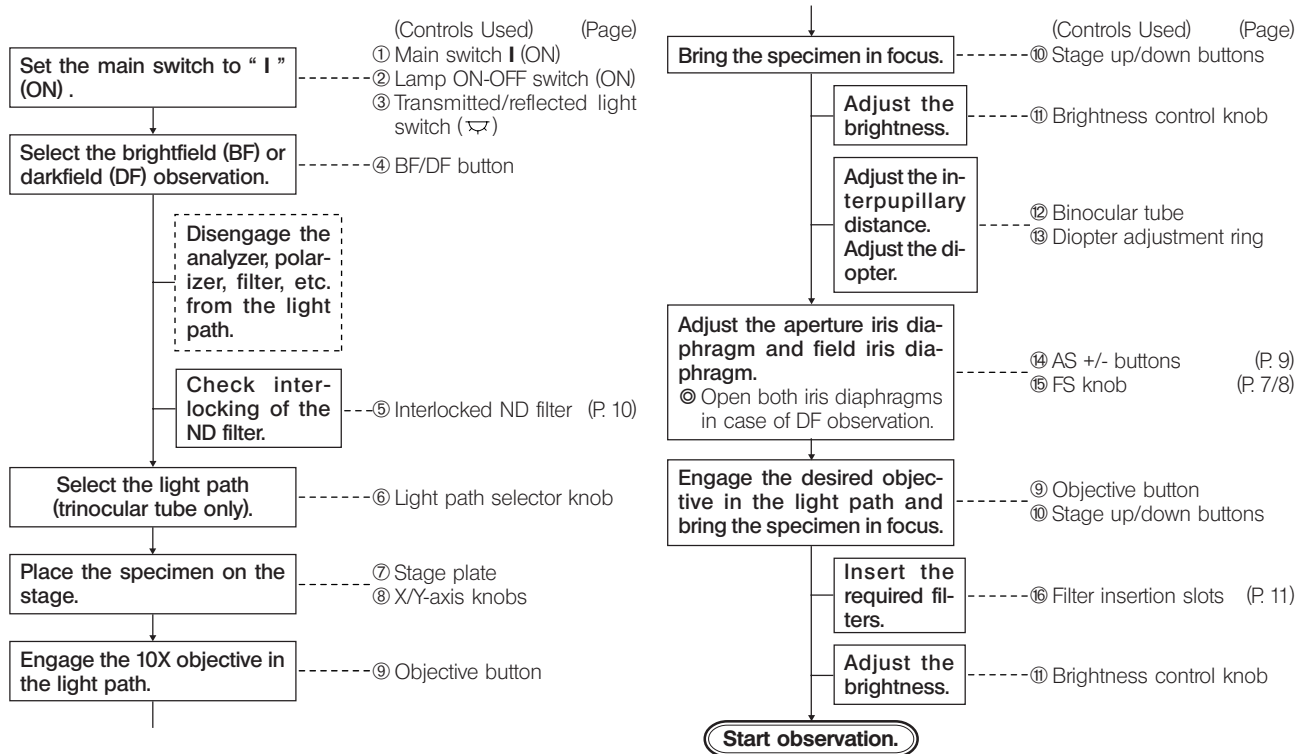

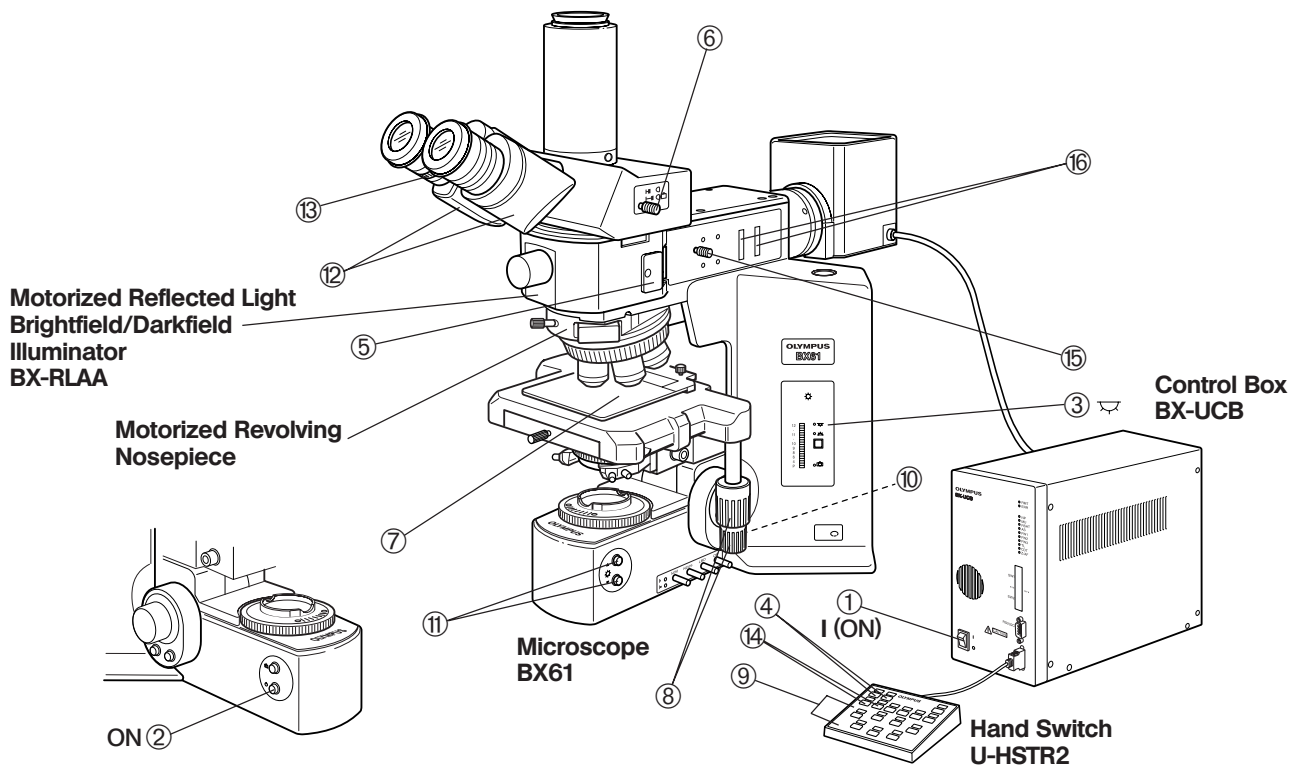

© Make a photocopy of the observation procedure pages and post it near your microscope.

4 USING THE CONTROLS OF BX-RLAA

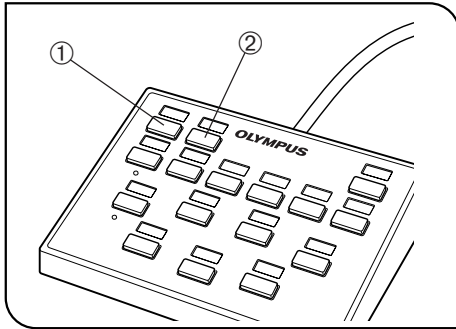

Fig. 1

1 Selecting the Observation Path

(Fig. 1)

Select the mirror for the desired observation method by pressing the BF button ① or DF button ② on the hand switch.

BF: Reflected light brightfield observation

DF: Reflected light darkfield observation

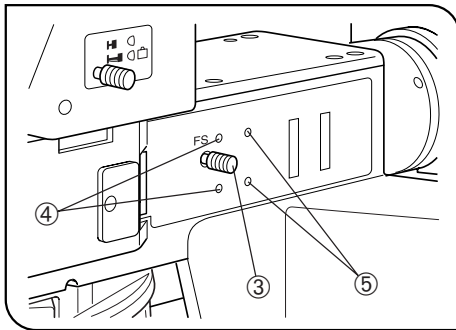

Fig. 2

2 Centering the Field Iris Diaphragm (FS)

(Figs. 1 & 2)

1. Press the BF button ① on the hand switch to select the reflected light brightfield path.
2. Engage the 10X objective, place the specimen on the stage and adjust approximate focusing.
3. Pull out the FS knob ③ on the reflected light illuminator to reduce the aperture iris diaphragm a little.
4. Rotate the two FS centering screws ④ using the Allen screwdriver to adjust so that the field iris image becomes concentric with the field of view.
5. While pushing in the FS knob ③, open the field iris diaphragm until the field iris image inscribes the field of view. If the image is found to be eccentric, adjust the field diaphragm centering again.

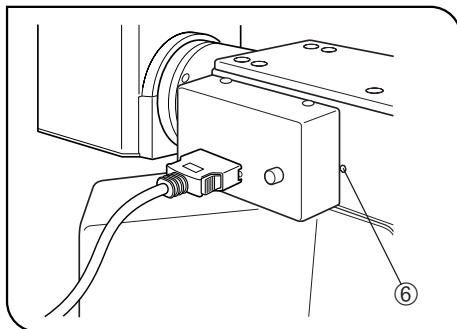
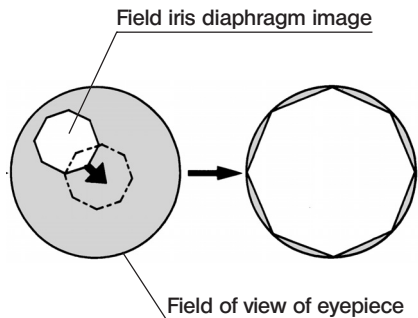

Fig. 3

- Open the field iris so that its image is almost the same size as (i.e. subtends) the field of view.

Using the Field Iris Diaphragm

- In **reflected light brightfield observation**

The field iris diaphragm adjusts the illuminated area to obtain an image with high contrast.

According to the objective in use, adjust the FS knob ③ of the reflected light illuminator until the iris image circumscribes the field of view to block unnecessary light.

- In **reflected light darkfield observation**

The field iris must be opened by pushing in the FS knob ③.

3 Centering the Aperture Iris Diaphragm (AS) (Figs. 3 & 4)

⊙ Before AS centering, unlock it by loosening the lock screw ⑥ on the left side panel of the reflected light illuminator using the 3 mm Allen wrench. After completing AS centering, be sure to lock the screw again.

- Press the BF button (① in Fig. 1) on the hand switch to select the reflected light brightfield path.
 - Engage the 10X objective and bring the specimen in approximate focus.
- ⊙ To improve the visibility of the aperture iris image, it is recommended to use a specimen with high reflectivity such as a mirror.

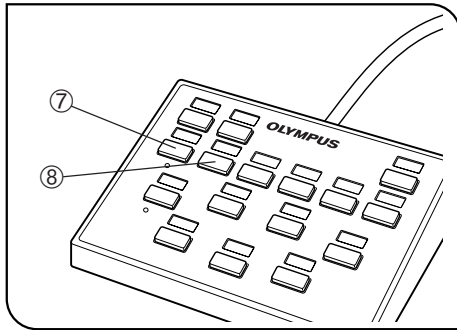
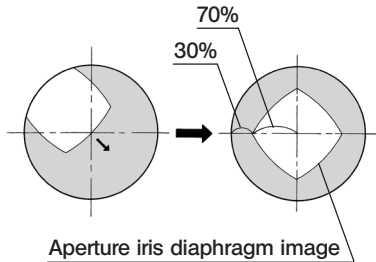

Fig. 4



3. Remove the eyepiece, look into the eyepiece sleeve and press the AS – button ⑦ on the hand switch to set the aperture at around 70%.
4. If the center of the iris diaphragm is deviated, center it by rotating the two AS centering screws (⑤ in Fig. 2) using the Allen screwdriver.

Using the Aperture Iris Diaphragm

- In **reflected light brightfield observation**, optimum observation is generally possible by setting the aperture to between 70% and 80% of the aperture number of the objective.
 - In **reflected right darkfield observation**, the aperture must be fully opened by pressing the AS + button ⑧.
- ④ With some specimens, an image with high contrast and little flare may sometimes be obtained when the aperture is slightly closed. It is therefore recommended to also try a slightly closed aperture.

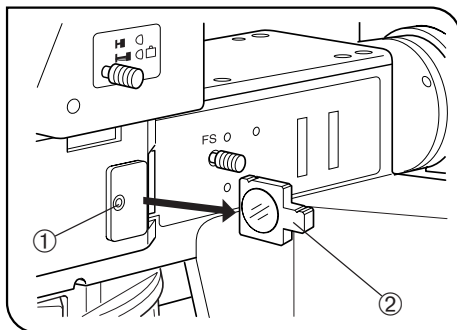

Fig. 5

4 Using the Interlocked ND Filter

(Fig. 5)

◎ The ND filter is interlocked with the brightfield (BF) light path switching and makes it possible to reduce glare when the darkfield (DF) path is switched to the brightfield (BF) path.

Removing the Interlocked ND Filter

◎ The ND filter has been interlocked at the factory. If brightness is not enough during brightfield, DIC or other observation, remove the ND filter as described below.

1. Select the DF observation path, and remove the interlocked ND filter cover by loosening the retaining screw ① screw using the Allen screwdriver.
2. Remove the ND filter frame ② which is visible after the cover removal.
3. Attach the cover to the original position.

★ **To attach the removed ND filter again, push in the frame lightly. Do not push with an excessive force. If the force is excessive, the ND filter will be disengaged from the DF path and the main switch of the BX-UCB should be set to “I” (ON) then “O” (OFF) again.**

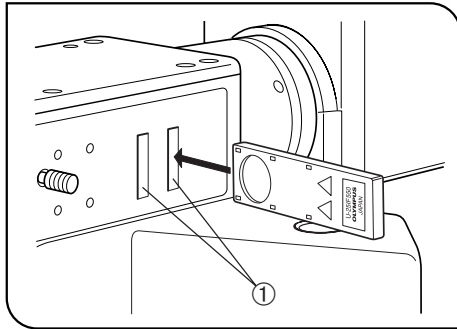

Fig. 6

5 Using the Filters

(Fig. 6)

- Ⓞ Engage the optimum filter sliders for the purpose of observation in the two filter insertion slots ① so that the filter surfaces with indication comes on the front.
The first click position is the idle position and the second click engages the filter in the light path.

Usable Filters	Applications
U-25LBD (Color temperature conversion filter)	Turns the illumination light into daylight. Used in general observations and color photography.
U-25IF550 (Green filter)	Enhanced contrast in monochrome observation. Used in monochrome photography.
U-25Y48 (Yellow filter)	Yellow filter for observation of semiconductor wafers.
U-25ND50-2 (Light intensity adjustment filter)	Adjusts the brightness of the light source. (Transmittance: 50%)
U-25ND25-2 (Light intensity adjustment filter)	Adjusts the brightness of the light source. (Transmittance: 25%)
U-25ND6-2 (Light intensity adjustment filter)	Adjusts the brightness of the light source. (Transmittance: 6%)
U-25FR (Frost filter)	Reduces irregularity in the illumination field, but also reduces the brightness.
U-25L42 (UV cut filter)	Cut ultraviolet rays. Used to prevent the polarizer from being burnt by a high-intensity light source.

5 STAGE FOR METALLURGICAL SPECIMENS

◎ To improve the ease of operation, it is recommended to use a stage for exclusive use with metallurgical specimens or replace the biological specimen holder with that for metallurgical use.

1 Placing the Specimen

◎ The maximum load capacities are as follows.

- Stage: 1.5 kg
- Stage plate
 - 500 g (U-SVRM/SVLM)
 - 1 kg (U-SIC4R2/SIC4L2)

★ If a specimen heavier than the specified weight is placed, phenomena such as deterioration of the feeling of stage movement and parts wear may occur.

With the U-MSSP or U-MSSP4 Stage Plate

Place the specimen on the stage plate ①.

◎ The specimen should be parallel and planar. Otherwise, the reflected light cannot reach the objective, rendering observation impossible.

◎ When observing very large specimens, remove the stage plate and place the specimen directly on the stage.

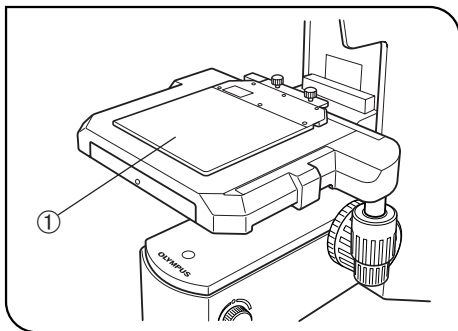

Fig. 7

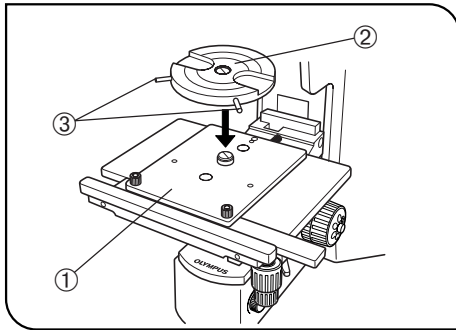

Fig. 8

[U-SIC4R2/SIC4L2 Stage Only]

Observation with the U-WHP2 Wafer Holder Plate (Fig. 8)

1. Place the BH2-WHR43 rotary wafer holder (for 3- or 4-inch) ② on the U-WHP2 wafer holder plate ①.
2. Place a 3-inch or 4-inch wafer on the BH2-WHR43 and observe the wafer. The wafer holder plate can be rotated with the knob ③.

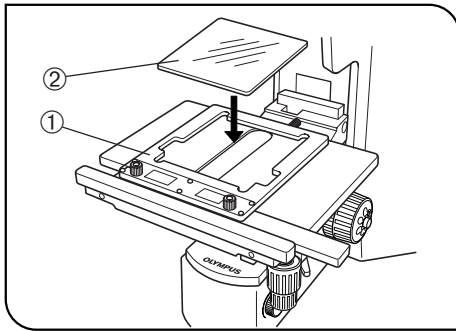

Fig. 9

[U-SIC4R2/SIC4L2 Stage Only]

Observation with the U-MSSPG Glass Holder Plate (Fig. 9)

- Ⓞ If the microscope is equipped with transmitted light illumination, transparent specimens can also be observed.
1. Place the glass plate ② gently on the glass holder plate ①.
 2. Place a specimen or transparent specimen and observe it.

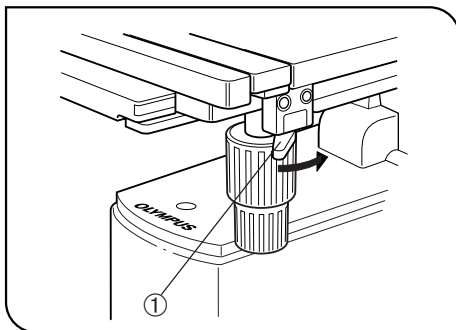

Fig. 10

2 Using the Y-Axis Movement Lock Lever (Fig. 10)

© This mechanism is provided only with the U-SIC4R2/SIC4L2 stage.

1. When the Y-axis movement lock lever ① is locked by setting the lever in the direction of the arrow, the Y-axis movement is locked, making it possible to scan only in the X-axis direction.
2. To release the lock, return the lever to the original position.

★ If the lock lever is released incompletely, the lever will be worn out, making locking impossible or causing dust.

6 OBSERVATION METHODS (Using BX-RLAA)

6-1 Reflected Light Brightfield/Darkfield Observation

See "MOTORIZED REFLECTED LIGHT BRIGHTFIELD/DARKFIELD OBSERVATION PROCEDURE" on page 5.

6-2 Reflected Light Nomarski DIC (Differential Light Contrast) Observation

- ★ The performance of polarizer may deteriorate when it has been exposed to light for a long period (about continuous 2000 hours). If this happens, replace the polarizer.
- ★ When performing sensitive color observation using the U-DICRH DIC slider, combine the U-POTP3 polarizer.
- ★ When using the high-intensity light source, be sure to use the U-25L42 filter to prevent the polarizer from being burnt.

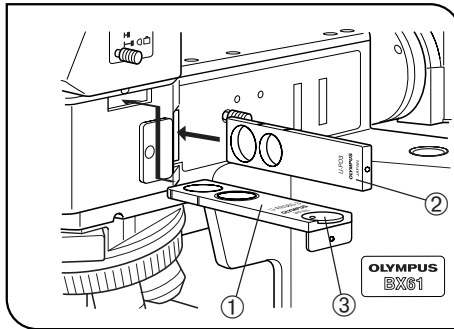

Fig. 11

1 Setting the Analyzer and Polarizer

(Fig. 11)

★ In the current step, do not engage the DIC slider in the light path.

1. Bring the specimen in approximate focusing using the 10X or 20X objective.
2. Remove the cover to enable installation of the U-AN360-3 analyzer. Then put the analyzer ① in the insertion slot.
3. Insert the U-PO or U-POTP3 polarizer ② so that the surface with indication comes on the front, and engage the polarizer in the light path.
4. Rotate the analyzer rotating dial ③ to find the position where the field of view is darkest.

◎ An approximate crossed-Nicol position can be obtained by setting the index on the dial ③ on the outer side. Fine-adjust the dial by rotating it near this position to find the position where the field of view is darkest.

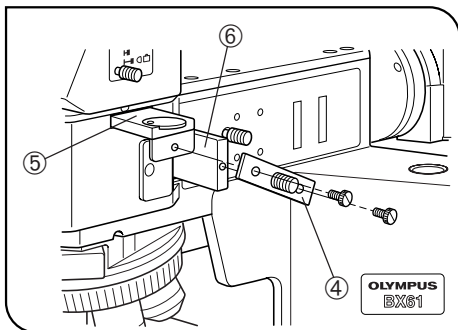

Fig. 12

Using the Joint Plate (Fig. 12)

When the U-AN360-3 analyzer ⑤ and U-PO3 or U-POTP3 polarizer ⑥ are coupled by using the joint plate ④ provided with the polarizer and tightening the clamping knobs on it, the analyzer and polarizer can be engaged or disengaged in the light path together.

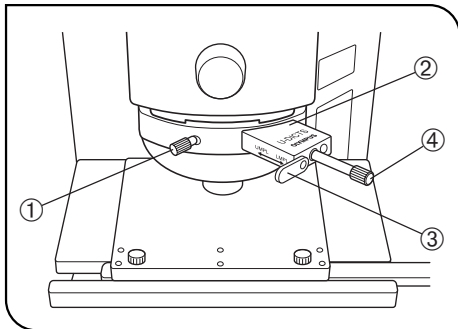

Fig. 13

2 Setting the DIC Slider (Fig. 13)

1. Loosen the mounting knob ① on the front of the DIC revolving nosepiece, insert the DIC slider ② so that the surface with indication faces up, and clamp by tightening the mounting knob.
2. With the U-DICR interference slider, set the slide lever ③ according to the objective in use.

Lever ③ position	Applicable Objectives	
Pushed in	UIS2	MPLFLN/MPLFLN-BD series MPLAPON series
	UIS	UMPlanFI/UMPlanFI-BD series MPlanApo20X, 100X MPlanApo100XBD
Pulled out	UIS2	LMPLFLN/LMPLFLN-BD series
	UIS	LMPlanFI/LMPlanFI-BD series LMPlanApo/LMPlanApo-BD series

3. With the U-DICRH or U-DICRHC slider that does not have the slide lever, the applicable objectives are as follows.

DIC Slider	Applicable Objectives	
U-DICRH	UIS2	MPLFLN/MPLFLN-BD series MPLAPON series
	UIS	UMPlanFI/UMPlanFI-BD series MPlanFI-BD series MPlanApo20X, 100X
U-DICRHC	UIS2	LMPLFLN/LMPLFLN-BD series
	UIS	LMPlanFI/LMPlanFI-BD series LMPlanApo/LMPlanApo-BD series

3 Observation Method

(Fig. 13)

1. Place the specimen on the stage and adjust the focus by moving the stage up or down.
2. Adjust the field iris diaphragm so that its image circumscribes the field of view.
3. The contrast may sometimes be enhanced by closing the aperture iris diaphragm slightly.

U-DICR**U-DICRHC**

1. Adjust the background contrast by turning the prism movement knob ④ on the DIC slider as described below. (Fig. 13)
2. When the prism movement knob on the U-DICR or U-DICRHC DIC slider is turned, the interference color in the background varies continuously from the gray sensitive color to magenta sensitive color (from -100 to 600 nm). Set the interference color which can provide best contrast with respect to the specimen.
 - Selecting a gray background color enables 3D-looking observation with high contrast thanks to the highest sensibility of the gray sensitive color.
 - Selecting a magenta sensitive color allows even small phase variation to be observed as a change in color.

U-DICRH

1. Adjust the background contrast by turning the prism movement knob ④ on the DIC slider as described below. (Fig. 13)
2. When the prism movement knob on the U-DICRH DIC slider is turned, the interference color in the background varies from -100 to 100 nm. Set the retardation which can provide best contrast.

- Selecting a gray background color enables 3D-looking observation with high contrast thanks to the highest sensibility of the gray sensitive color.
- Selecting a magenta sensitive color allows even small phase variation to be observed as a change in color.

To select the magenta sensitive color as the background color, use the U-POTP3 polarizer and insert it so that the λ indication can be seen from the front.

★ **Since the DIC observation has a high detection sensitivity, take care against contamination on the specimen surface.**

◎ The detection sensitivity is variable depending on direction so it is recommended to use a rotary stage.

4 Switching to Brightfield/Darkfield Observation (Fig. 13)

1. Loosen the mounting knob ① on the front of the DIC revolving nosepiece, gently pull out the DIC slider ② until it clicks, then clamp by tightening the mounting knob.
2. Slide the analyzer (U-AN360-3) and polarizer to disengage them from the light path.

6-3 *Reflected Light Simplified Polarized Light Observation*

©For the preparation of reflected light simplified polarized light observation, perform the operation in “1 Setting the Analyzer and Polarizer” in section 6-2, “Reflected Light Nomarski DIC Observation”.

1 Observation Method

1. Place the specimen on the stage and adjust the focus by moving the stage up or down. Now simplified polarized light observation can be started.
2. Adjust the field iris diaphragm so that its image circumscribes the field of view.
3. The contrast may sometimes be enhanced by closing the aperture iris diaphragm slightly.

7 SPECIFICATIONS

Module	Specification
Motorized Reflected Light Brightfield/Darkfield Illuminator BX-RLAA Power Source: Control Box BX-UCB Control Source: Hand Switch U-HSTR2 or PC	<ul style="list-style-type: none"> • UIS2 (UIS) (Universal Infinity System) optical system • Tube magnification 1X, super widefield (FN 26.5) compatible • Observation method switching: Motorized BF/DF switching • Aperture iris diaphragm: Motorized opening/closing (ϕ 0.4 to 11.1 mm), centering possible • Field iris diaphragm: Manual knob opening/closing, centering possible • Filter slider insertion slots: x 2 • Motorized revolving nosepiece connector provided (Connector position fixed at the factory) • Available observations: <ol style="list-style-type: none"> ① Reflected light brightfield ② Reflected light darkfield ③ Reflected light Nomarski DIC ④ Reflected light simplified polarized light • Applicable microscope: BX61
Operating environment	<ul style="list-style-type: none"> • Indoor use. • Altitude: Max. 2000 meters • Ambient temperature: 5° to 40°C (41° to 104° F) • Maximum relative humidity: 80% for temperatures up to 31°C (88°F), decreasing linearly through 70% at 34°C (93°F), 60% at 37°C (99°F), to 50% relative humidity at 40°C (104°F). • Supply voltage fluctuations; Not to exceed \pm10% of the normal voltage. • Pollution degree: 2 (in accordance with IEC60664) • Installation/Overvoltage category: II (in accordance with IEC60664)

8

OPTICAL CHARACTERISTICS «UIS2 Series»

- The UIS series objectives that are not mentioned below can also be mounted on this microscope. -

The table below shows the optical characteristics of different eyepiece and objective combinations. Objective specifications are marked on the objective (as shown in the diagram on the right).

NOTE

Refer to the latest catalogue or consult Olympus for the updated information on the eyepieces and objectives that can be combined with this unit.

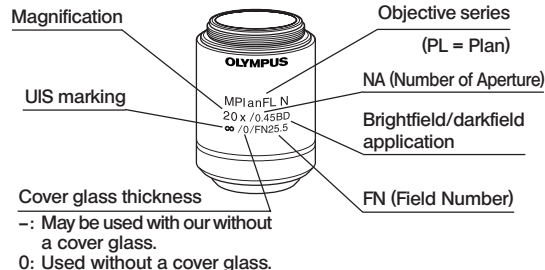

Optical characteristics		Magnification	N.A.	W.D. (mm)	Cover glass thickness (mm)	Resolution (µm)	Eyepieces						
							WHN10X (FN22)			SWH10X (FN26.5)			
							Total mag.	Depth of focus (µm)	Field of view (mm)	Total mag.	Depth of focus (µm)	Field of view (mm)	
Series	Marking												
UIS2 series	MPLN Plan Achromat (FN22)	MPlanN	5X	0.10	20.0	-	3.36	50X	98	4.4	-	-	-
			10X	0.25	10.6	-	1.34	100X	18	2.2			
			20X	0.40	1.3	0	0.84	200X	6.1	1.1			
			50X	0.75	0.38	0	0.45	500X	1.4	0.44			
			100X	0.90	0.21	0	0.37	1000X	0.73	0.22			
	MPLN-BD Brightfield/darkfield Plan Achromat (FN22)	MPlanN-BD	5X	0.10	12.0	-	3.36	50X	98	4.4	-	-	-
			10X	0.25	6.5	-	1.34	100X	18	2.2			
			20X	0.40	1.3	0	0.84	200X	6.1	1.1			
			50X	0.75	0.38	0	0.45	500X	1.4	0.44			
			100X	0.90	0.21	0	0.37	1000X	0.73	0.22			
	MPLFLN Plan Semi-Apochromat (FN26.5) *1.25X:FN22	MPlanFLN	1.25X	0.04	3.5	-	8.39	12.5X	870	176	-	-	-
			2.5X	0.08	10.7	-	4.19	25X	220	8.8	25X	220	10.6
			5X	0.15	20.0	-	2.24	50X	59	4.4	50X	59	5.3
			10X	0.30	11.0	-	1.12	100X	15	2.2	100X	15	2.65
			20X	0.45	3.1	0	0.75	200X	5.2	1.1	200X	5.2	1.33
			50X	0.80	1.0	0	0.42	500X	1.3	0.44	500X	1.3	0.53
			100X	0.90	1.0	0	0.37	1000X	0.73	0.22	1000X	0.73	0.27

Optical characteristics Series Marking			Magnification	N.A.	W.D. (mm)	Cover glass thickness (mm)	Resolution (μm)	Eyepieces					
								WHN10X (FN22)			SWH10X (FN26.5)		
								Total mag.	Depth of focus (μm)	Field of view (mm)	Total mag.	Depth of focus (μm)	Field of view (mm)
UIS2 series	MPLFLN-BD Brightfield/ darkfield Plan Semi- Achromat (FN26.5)	MPlanFLN-BD	5X	0.15	12.0	-	2.24	50X	59	4.4	50X	59	5.3
			10X	0.30	6.5	-	1.12	100X	15	2.2	100X	15	2.65
			20X	0.45	3.0	0	0.75	200X	5.2	1.1	200X	5.2	1.33
			50X	0.80	1.0	0	0.42	500X	1.3	0.44	500X	1.3	0.53
			100X	0.90	1.0	0	0.37	1000X	0.73	0.22	1000X	0.73	0.27
	MPLFLN-BDP Reflected Polarized Light Plan Semi- Achromat (FN26.5)	MPlanFLN-BDP	5X	0.15	12.0	-	2.24	50X	59	4.4	50X	59	5.3
			10X	0.25	6.5	-	1.34	100X	18	2.2	100X	18	2.65
			20X	0.40	3.0	0	0.84	200X	6.1	1.1	200X	6.1	1.33
			50X	0.75	1.0	0	0.45	500X	1.4	0.44	500X	1.4	0.53
	LMPLFLN Long-WD Plan Semi-Achromat (FN26.5)	LMPlanFLN	100X	0.90	1.0	0	0.37	1000X	0.73	0.22	1000X	0.73	0.27
			5X	0.13	22.5	-	2.58	50X	70	4.4	50X	70	5.3
			10X	0.25	21.0	-	1.34	100X	18	2.2	100X	18	2.65
			20X	0.40	12.0	0	0.84	200X	6.1	1.1	200X	6.1	1.33
	LMPLFLN-BD Brightfield/darkfield long-WD Plan Semi- Achromat (FN26.5)	LMPlanFLN-BD	50X	0.50	10.6	0	0.67	500X	2.5	0.44	500X	2.5	0.53
			100X	0.80	3.4	0	0.42	1000X	0.87	0.22	1000X	0.87	0.27
			5X	0.13	15.0	-	2.58	50X	70	4.4	50X	70	5.3
			10X	0.25	10.0	-	1.34	100X	18	2.2	100X	18	2.65
	SLMPLN Superlong-WD Plan Achromat (FN26.5)	SLMPlanN	20X	0.40	12.0	0	0.84	200X	6.1	1.1	200X	6.1	1.33
			50X	0.50	10.6	0	0.67	500X	2.5	0.44	500X	2.5	0.53
			100X	0.80	3.3	0	0.42	1000X	0.87	0.22	1000X	0.87	0.27
			20X	0.25	25.0	0	1.34	200X	11.4	1.1	200X	11.4	1.33
			50X	0.35	18.0	0	0.96	500X	4.2	0.44	500X	4.2	0.53
			100X	0.60	7.5	0	0.56	1000X	1.3	0.22	1000X	1.3	0.27

Note) When an MPLN-BD series objective is used in darkfield observation with a xenon light source, the peripheral area may be obscured with certain specimens.

Optical characteristics		Magnification	N.A.	W.D. (mm)	Cover glass thickness (mm)	Resolution (μm)	Eyepieces						
							WHN10X (FN22)			SWH10X (FN26.5)			
							Total mag.	Depth of focus (μm)	Field of view (mm)	Total mag.	Depth of focus (μm)	Field of view (mm)	
Series	Marking												
UIS2 series	MPLAPON Plan Apochromat	MPlanApoN	50X	0.95	0.35	0	0.35	500X	0.7	0.44	500X	0.7	0.53
			100X	0.95	0.35	0	0.35	1000X	0.4	0.22	1000X	0.4	0.27

Objectives for LCD Panel

Optical characteristics		Magnification	N.A.	W.D. (mm)	Cover glass thickness (mm)	Resolution (μm)	Eyepieces						
							WHN10X (FN22)			SWH10X (FN26.5)			
							Total mag.	Depth of focus (μm)	Field of view (mm)	Total mag.	Depth of focus (μm)	Field of view (mm)	
Series	Marking												
UIS2 series	LCPLFLN Long-WD Plan Semi-Apochromat (FN26.5)	LCPlanFLN*	20XLCD	0.45	7.4-8.3	0-1.2	0.75	200X	5.2	1.1	200X	5.2	1.33
			50XLCD	0.70	2.2-3	0-1.2	0.48	500X	1.6	0.44	500X	1.6	0.53
			100XLCD	0.85	0.9-1.2	0-0.7	0.39	1000X	0.79	0.22	1000X	0.79	0.27

* Equipped with the glass thickness compensation ring.

Glossary of Terms Used in the Optical Characteristics Table

- Working distance (WD) : The distance from the top of specimen and the front lens of objective.
- Number of aperture (NA) : Important figure determining the objective characteristics (resolution, focal depth and brightness).
 - Resolution Increases in proportion with the NA
 - Focal depth Decreases in proportion with the NA
 - Brightness Proportional with the square of NA (comparison under the same magnification).
- Resolution : The limit that an objective can identify the images of two points that are close to each other, expressed as the distance between the two points on the specimen.
- Depth of focus : The maximum depth of the specimen at which the entire specimen can be brought into focus simultaneously. This value increases when the aperture iris diaphragm is narrowed and decreases when the objective NA is increased.
- Field number : The diameter of the image area that can be observed through the eyepieces, expressed in mm.
- Field of view : The diameter of the area observable on the specimen, expressed in mm.

9 ASSEMBLY

©For assembly of the BX-UCB control box and U-HSTR2 hand switch, refer to their instruction manual.

★If the connector of the U-UCD8A motorized universal condenser is attached to the BX-UCB, the BX-RLAA motorized reflected light illuminator cannot work normally. Be sure to unplug the connector if it is connected.

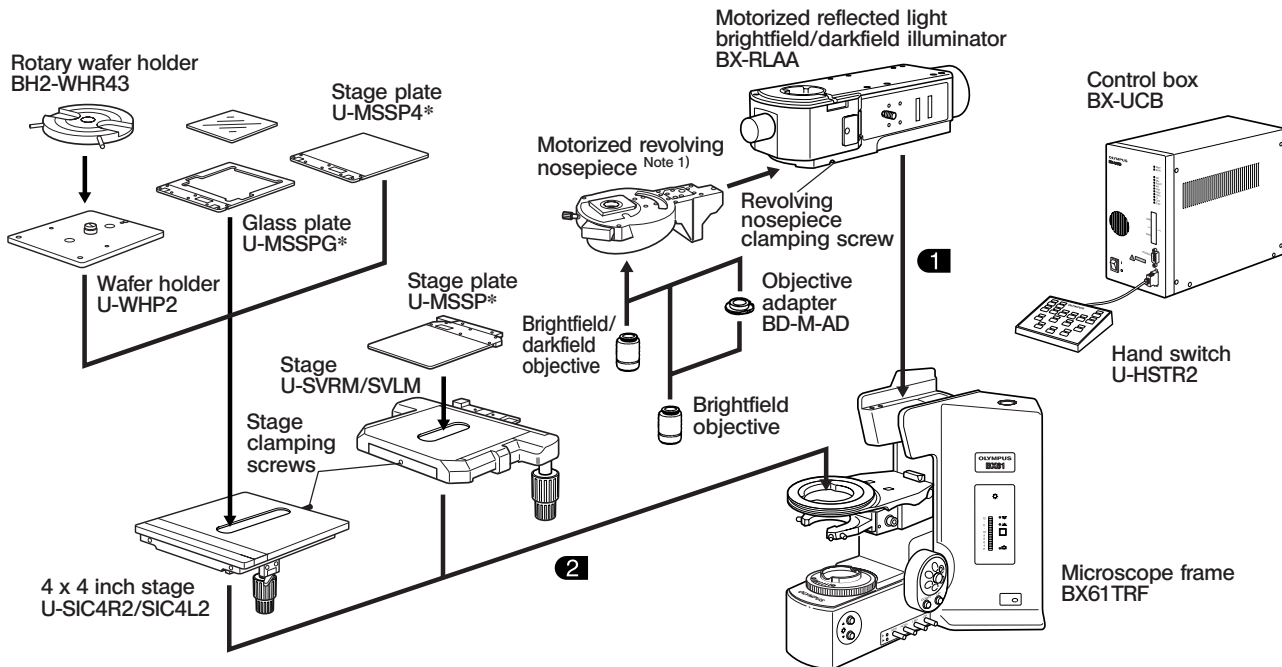

*Warp prevention pins (2 for each) are attached on the bottom sides of the U-MSSP/MSSP4 stage plate and the U-MSSPG glass plate when the system is shipped from the factory. Remove the pins before use.

Note 1) With certain motorized revolving nosepieces, the connector of the BX-RLAA illuminator should be unlocked before operation.

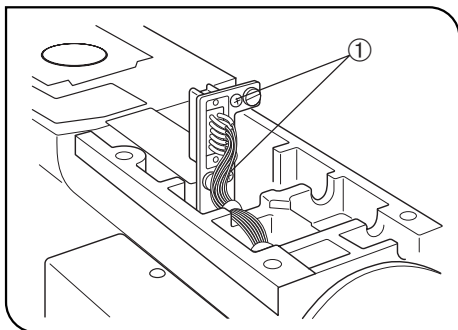

Fig. 14

Preparation for Mounting the Motorized Revolving Nosepiece (Fig. 14)

Ⓞ With certain motorized revolving nosepiece series, the connector of the BX-RLAA reflected light illuminator should be unlocked before operation.

U-D6REM/5BDREM

The connector can be connected by mounting the revolving nosepiece in the same way as manual revolving nosepiece.

For the connection of the motorized revolving nosepiece, be sure to insert the motorized revolving nosepiece all the way until it is stopped.

U-D6REMC/D6BDREMC/D5BDREMC/P5BDREMC/P5REMC

The connector is unlocked by removing the screw ① fixed at the factory using a Phillips screwdriver. Then the revolving nosepiece can be attached in the same way as above.

To lock the connector again:

Attach the motorized revolving nosepiece on the illuminator and tighten the screws ①.

In this case, the illuminator is incompatible with other motorized revolving nosepieces so it may become capable of being connected only with the combined motorized revolving nosepiece.

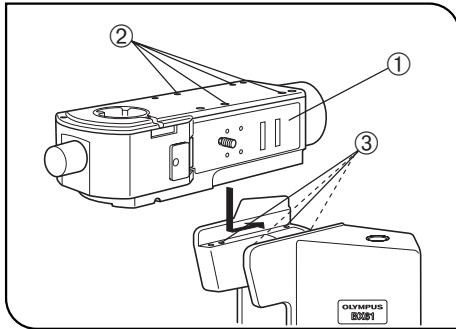



Fig. 15

1 Attaching the Illuminator

(Fig. 15)

- ⊙ Attach the illuminator using the Allen wrench () provided with it.
 - ⊙ Remove the caps of the mounting screws ② using a pair of tweezers, etc.
1. Place the illuminator ① on the mounting surface by slightly deviating the 4 mounting screws ② of the illuminator toward the front of the 4 mounting screw holes ③ on the microscope frame. For the present, it is not required to align the illuminator's mounting screws with the microscope's mounting screw holes.
 2. Apply the illuminator toward the rear of the microscope frame. The illuminator will fit in the correct position.
 3. While maintaining the correct condition by pushing the illuminator toward the rear, tighten the 4 mounting screws ② by turning it clockwise using the Allen wrench.
 4. Place the caps of mounting screws ② on the original position

2 Attaching the Stage

Tighten the stage clamping screw.

- ★ If the specimen holder of the U-SVRB-4/SVLB-4 biological stage has been replaced with the stage plate, the back side of the stage plate may be worn after long period of use because the upside of the biological stage is ceramic coated.

MEMO

MEMO

Manufactured by

EVIDENT CORPORATION

6666 Inatomi, Tatsuno-machi, Kamiina-gun, Nagano 399-0495, Japan

Distributed by

EVIDENT EUROPE GmbH

Caffamacherreihe 8-10, 20355 Hamburg, Germany

EVIDENT EUROPE GmbH UK Branch

Part 2nd Floor Part A, Endeavour House, Coopers End Road, Stansted CM24 1AL, U.K.

EVIDENT SCIENTIFIC, INC.

48 Woerd Ave Waltham, MA 02453, U.S.A.

EVIDENT AUSTRALIA PTY LTD

97 Waterloo Road, Macquarie Park, NSW 2113, Australia

Life science solutions

Service Center



[https://www.olympus-lifescience.com/
support/service/](https://www.olympus-lifescience.com/support/service/)

Official website



<https://www.olympus-lifescience.com>

Industrial solutions

Service Center



[https://www.olympus-ims.com/
service-and-support/service-centers/](https://www.olympus-ims.com/service-and-support/service-centers/)

Official website



<https://www.olympus-ims.com>