

INSTRUCTIONS

STM7

Measuring microscope

This instruction manual is for the Evident measuring microscope.

To ensure the safety, obtain optimum performance and to familiarize yourself fully with the use of this microscope, we recommend that you study this manual thoroughly before operating the microscope.

Retain this instruction manual in an easily accessible place near the work desk for future reference.

For details of products included in the configuration of this system, see page 13 and 14 of this instruction manual.

Optical Microscope and Accessory

This product is applied with the requirements of standard IEC/EN61326-1 concerning electromagnetic compatibility.

- Emission Class A
- Immunity Industrial electromagnetic environment

Emissions exceeding the level required by aforementioned standards may occur if this product is electrically connected to other equipment.

Some interference may occur if this product is used in residential environments.



In accordance with European Directive on Waste Electrical and Electronic Equipment, this symbol indicates that the product must not be disposed of as unsorted municipal waste, but should be collected separately.

Refer to your local Evident distributor in EU for return and/or collection systems available in your country.

NOTE: This product has been tested and found to comply with the limits for a Class A digital device, pursuant to Part 15 of the FCC Rules. These limits are designed to provide reasonable protection against harmful interference when the product is operated in a commercial environment. This product generates, uses, and can radiate radio frequency energy and, if not installed and used in accordance with the instruction manual, may cause harmful interference to radio communications.

Operation of this product in a residential area is likely to cause harmful interference in which case the user will be required to correct the interference at his own expense.

FCC WARNING: Changes or modifications not expressly approved by the party responsible for compliance could void the user's authority to operate the product.

For Korea only

이 기기는 업무용 환경에서 사용할 목적으로 적합성평가를 받은 기기로서 가정용 환경에서 사용하는 경우 전파간섭의 우려가 있습니다.

Contents

Introduction	1
Releasing the transport lock.....	1
Safety precautions	2
1 Nomenclature of module	13
2 Nomenclature of operating portions	15
3 Operation procedures	22
3-1 Turning Power ON	22
1 Functioning of Modules.....	22
2 X/Y/Z display.....	23
3-2 Focusing unit (Manual frame only).....	24
1 Focusing operation.....	24
2 Adjusting the coarse focusing knob tension.....	24
3-3 Hand switch (Manual frame only).....	25
1 Controlling illumination.....	25
2 Resetting counter data of X-, Y- and Z-axis.....	26
3 Outputting counter data of X-, Y- and Z-axis.....	27
4 Counting counter data of X-, Y- and Z-axis in-half.....	27
3-4 Focus controller (Motorized frame only).....	28
1 Z-axis coarse focusing.....	28
2 Z-axis fine/coarse adjustment with fine/coarse focusing knob.....	28
3 Controlling illumination.....	29
4 Resetting counter data of X-, Y- and Z-axis.....	31
5 Outputting counter data of X-, Y- and Z-axis.....	31
6 Counting counter data of X-, Y- and Z-axis in-half.....	31
7 Setting lower software limit.....	32
3-5 Observation tube.....	33
1 Interpupillary distance adjustment (MM6-ETR).....	33
2 Diopter adjustment.....	33
3 Using the eye shades.....	33
4 Replacing the eyepiece cross	34
5 Switching the light path (MM6-ETR).....	34

6	Erect image monocular observation tube (MM6-EMO).....	34
3-6	Reflected light illuminator.....	35
1	Switching the light path of brightfield/darkfield reflected light illuminator (MM6C-RLAS)....	35
2	Using the filters (MM6C-KMAS,MM6C-RLAS).....	35
3-7	Stage.....	36
1	Moving the specimen.....	36
2	Clamping the option and jig tool.....	37
3	Adjusting the parallelism of specimen.....	37
4	Replacing the stage glass.....	37
3-8	Focus navigator unit.....	38
1	Method of focus.....	38
3-9	Autofocus unit (Motorized frame only).....	39
1	Autofocusing modes.....	39
2	Focusing position adjustment.....	39
3	Measurement by manual readout in ONE SHOT mode.....	41
4	Measurement by auto readout in ONE SHOT mode.....	42
5	Measurement in TRACK mode.....	43
3-10	Foot switch.....	45
3-11	Basic software.....	45
3-12	External processing device.....	45
3-13	Printer.....	45
4	OBSERVATIONS (using MM6C-KMAS or MM6C-RLAS)	46
4-1	Reflected light brightfield observation.....	46
4-2	Reflected light DIC observation.....	46
1	Mounting the analyzer and polarizer.....	46
2	Setting the DIC slider.....	47
3	Observation procedure.....	47
4	Switching to brightfield observation.....	47

4-3 Reflected Light Simplified Polarized Light Observation.....	48
1 Observation procedure.....	48
5 MEASUREMENT	49
5-1 Preparation (setting DIP switch and rotary switch).....	49
5-2 Measurement of right-angle coordinates.....	54
5-3 Measurement of height (motorized frame only).....	54
5-4 Measurement of cylinders, round rods and screws.....	55
6 ASSEMBLY	56
6-1 Assembly Diagram.....	56
6-2 Detailed assembly procedures.....	57
6-3 Inputting setting values (maker setting mode).....	74
7 MOUNTING AND OPERATING A VIDEO SYSTEM	80
7-1 Adjusting the tilt of the camera.....	81
8 Specifications.....	83
9 Troubleshooting guide.....	90
■ Proper selection of the power supply cord.....	94



Introduction

Contents of instruction manuals

Since this microscope is expandable to a variety of systems, separate instruction manuals are prepared so that the user has to read only the manuals according to the user's own system.

Manual name	Main contents
Measuring microscope STM7 (this manual)	Operating procedures of the measuring microscope
Hand switch/Focus controller quick guide STM7-HS/STM7-MCZ	Easy operation procedures of the hand switch or the focus controller
Control box STM7-CB/CBA	Functions of the control box for manual/motorized STM7-CB or STM7-CBA
Autofocus unit STM7-AF	Functions of the autofocus

Descriptions of Z-axis manual type frame and motorized type frame

This microscope can be combined with the Z-axis motorized type frame or the manual type frame.

In this instruction manual, the Z-axis manual type frames (STM7-SF/STM7-MF/STM7-LF) are called "Manual frame" and the Z-axis motorized type frames (STM7-SFA/STM7-MFA/STM7-LFA) are called "Motorized frame".

Trademark

Microsoft, Excel, Internet Explorer, and Windows are either registered trademarks or trademarks of Microsoft Corporation in the United States and/or other countries.

Intel and Intel Core are trademarks of Intel Corporation in the U.S. and/or other countries.

Other company names or product names described in this manual are either registered trademarks or trademarks of respective companies.

Releasing the transport lock



- CAUTION** • Release the transport lock of the focusing unit and the stage after finishing unpacking.
- Never attempt to turn on the system without removing the clamping plate. Otherwise, the focusing unit and the stage may be damaged.

© When you release the transport lock, refer to page 58 for the focusing unit and page 61 for the stage.

Safety precautions

If the product is used in a manner not specified by this manual, the safety of the user may be imperiled. In addition, the product may also be damaged. Always use the equipment according to this instruction manual.

The following symbols are used in this instruction manual.

-  **CAUTION** : Indicates a potentially hazardous situation which, if not avoided, may result in minor or moderate injury.
-  **CAUTION** : Indicates a potentially hazardous situation which, if not avoided, may result in damage to the equipment or other property.
-  : Indicates commentary (for ease of operation and maintenance).

CAUTION - Installation of the device -

Install the STM7 on a rigid and levelled surface (such as a machine platen).

- Load capacity of table: STM7-SF/STM7-SFA: 200 kg; STM7-MF/STM7-MFA: 300 kg; STM7-LF/STM7-LFA: 500 kg
- Recommended table size: STM7-SF/STM7-SFA/STM7-MF/STM7-MFA: 1800(W)x750(D) mm;
STM7-LF/STM7-LFA: 1800(W)x900(D) mm

If the STM7 is not installed on a levelled surface, the stage may move spontaneously.

Basically, install the STM7 on a table with a thick top board. (Recommended top board thickness: 25 mm or more)

Do not put a mat, etc. under the microscope for safety.

Level the microscope in combination with the frame and the stage.

Always install the control box for motorized STM7-CBA Z-axis motorized type control box to allow operating the emergency stop switch.

The emergency stop switch is used to stop the motorized focusing unit in case of an emergency.

Confirm that the device is installed stably before use.

Operate the emergency stop switch before using devices, and make sure that the control box is not operated excessively.

CAUTION - Electric safety -

Always use the power cord provided by Evident.

If the proper power cord is not used, the electric safety and the EMC (Electro-Magnetic Compatibility) performance of the device can not be assured.

If no power cord is provided, please select the proper power cord by referring to the section "Proper selection of the power supply cord" at the end of this instruction manual.

Always connect the ground terminal.

Connect the ground terminal of the power cord and that of the power outlet.

Also, connect the functional ground cable of this system completely. (page 71)

If the device is not grounded, our intended electric safety and EMC performance of the device can not be assured.

Do not use the device in close proximity to the sources of strong electromagnetic radiation.

Proper operation may be interfered. The electromagnetic environment should be evaluated prior to operation of this device.

Remove the power cord in case of emergency.

In case of emergency, be sure to unplug the power cord from the power cord connector on the product or from the wall power outlet. Install the product at the location where you can reach the power cord connector or the wall power outlet at hand to remove the power cord quickly.

Be sure to turn OFF the power of the device before connecting /disconnecting cables and units.

This device is designed for use in Class A industrial environment for IEC61326-1 International Standard concerning EMC. Using it in a domestic environment may cause radio interference.

This device complies with the emission and immunity requirements described in IEC61326 series.

⚠ CAUTION - Protection for electric shock -

Do not insert any tools or metal fragments in the air vents of the device.

Doing so could cause electric shock or failure of the product.

Do not bend, pull or tie the power cord/cables in a bundle.

Otherwise they could be damaged, causing a fire or an electric shock.

Remove the power cord from the product when replacing the fuses.

To avoid electric shock hazards when replacing the fuses, turn the main switch to "O" (OFF), then remove the power cord from the product in advance.

Applicable fuses:		 T5 A H 250 V (LITTELFUSE 0215005.MXP)
-------------------	--	---

⚠ CAUTION - Protection for injury -

Do not touch around the opening of the Z-axis motorized type.

Your hands or fingers may be pinched.

⚠ CAUTION - Light from the objective lens -

Do not look directly at the light coming out from the objective lens and the reflected light from the measurement object.

Be careful about the light coming out from the objective lens, since not only visible light but also light of invisible wavelengths (such as ultraviolet and infrared) may be emitted depending on the illumination methods.

⚠ CAUTION - LED (light emitting diode) -

Do not look directly at the light from the LED unit for a long time.

The LED built in this product is basically eye-safe. However, do not look directly at the light from the LED unit for a long time, since it may cause damage to your eyes.

⚠ CAUTION - Safety symbols -

The following symbols are placed on the product.

Study the meaning of the symbols and always use the equipment in the safest possible manner.

Symbol	Meaning
⚠	Indicates a non-specific general hazard. Follow the cautions given after this symbol or in the instruction manual.
⚠	Be careful not to pinch your fingers at the stage or the stage holder.
I	Indicates that the main switch is ON.
○	Indicates that the main switch is OFF.

Caution labels

Cautions are displayed at the areas where special cautions are required when in use and operation. Be sure to follow the instructions.

Positions of caution labels	<ul style="list-style-type: none"> • Upper area of the stage X-axis knob • Upper area and lower area of the motorized frame (STM7-SFA/STM7-MFA/STM7-LFA) Z-axis guide. • Lower area of both sides of the column of the motorized frame (STM7-SFA/STM7-MFA/STM7-LFA) 	[Caution against pinching] 
-----------------------------	--	--

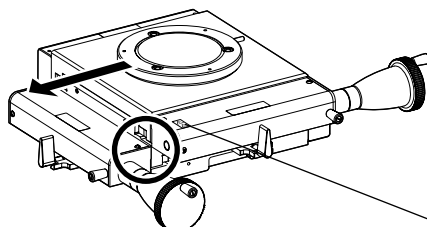

STM7-CS50/STM7-CS100

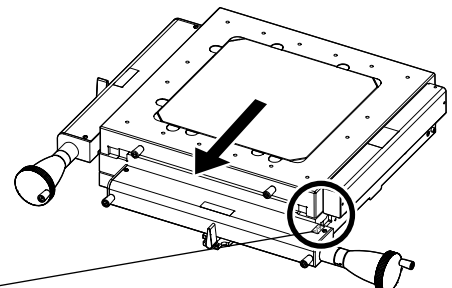

STM7-CS200/STM7-CS300

When the stage moves to in the arrow direction, your hands or fingers may be pinched.

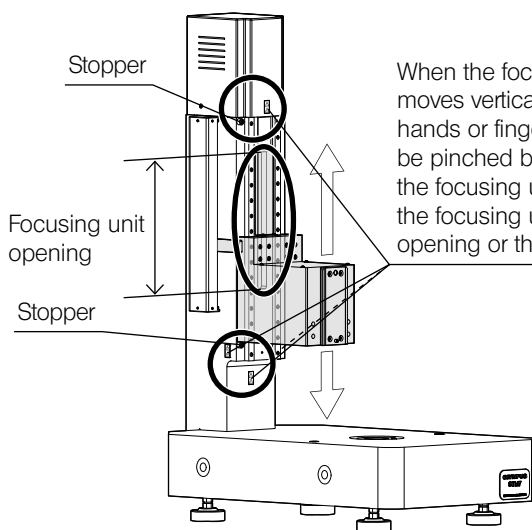

STM7-SFA/STM7-MFA

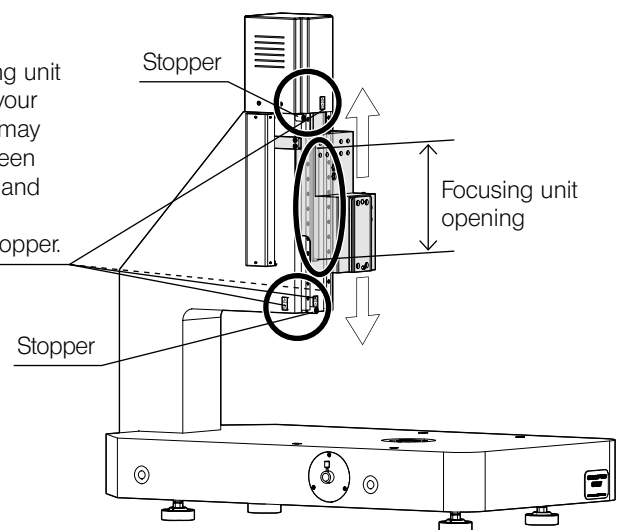

STM7-LFA

When the focusing unit moves vertically, your hands or fingers may be pinched between the focusing unit and the focusing unit opening or the stopper.

When caution labels are dirty or peeled off, contact Evident for replacement or inquiries.

Intended use

This product is designed for industrial measurements to measure the length, angle or contour of inspection objects, such as semiconductors, electronic/electric parts, precision automobile parts, resin molding, tools, etc.
Do not use this product for purposes other than described above.

Handling precautions

- CAUTION**
- This microscope is a precision instrument. Handle it with care and avoid subjecting it to a sudden or severe impact.
 - When the microscope is to be reinstalled or transported, be sure to secure the moving parts with the provided clamping devices and use the boxes in which the microscope was packed when you purchased it.
 - Never disassemble any part of the product. Otherwise, failure could be caused.
 - Do not use the system in areas where it may be subjected to direct sunlight, high temperature and/or humidity, dust or vibrations.
(For the operating environmental condition such as temperature and/or humidity, see "8 Specifications" (page 83).

Avoid using the instrument in the following places.

- (1) Near an inlet or exhaust outlet of air conditioning equipment, etc.
- (2) In a place subjected to large vibrations or change in temperature.
- (3) Near equipment producing abnormal noise (including non-Evident equipment)
- (4) In a place subjected to direct sunlight.
- (5) In a place subjected to excessive dirt or high temperature and humidity.
- (6) Near flammable substance (gasoline, lacquer thinner, alcohol, etc.)

- If you don't have any choice but to use the system in a place where temperature fluctuates significantly or where temperature and humidity are high, apply rust preventive oil on unpainted parts of the stage mount for rust may occur on that parts.
- Do not to block the air vents of the control box, the power supply unit and microscope frame, keep a space of 10 cm or more between the right/left/back sides and the surrounding objects.

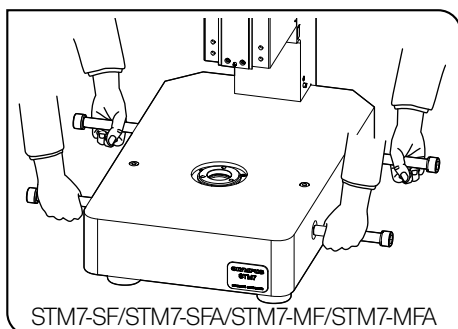

1. Each module is very heavy. Be sure to carry it by the following number of transport persons.
 - ◎ Number of transport persons per module: 1 or more persons (STM7-CS50, STM7-CS100); 2 or more persons (STM7-SF, STM7-SFA, STM7-MF, STM7-MFA, STM7-CS200); 4 or more persons (STM7-LF, STM7-LFA, STM7-CS300)
2. As a center of gravity is at the rear of the frame, the rear transport stick is heavier. Carry it carefully.
3. Carry the frame STM7-SF/STM7-SFA/STM7-MF/STM7-MFA using the transport sticks.

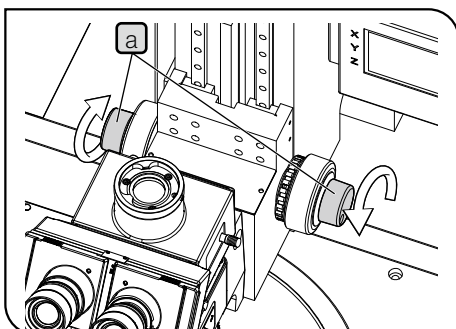
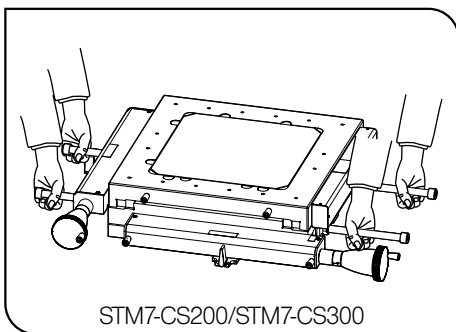
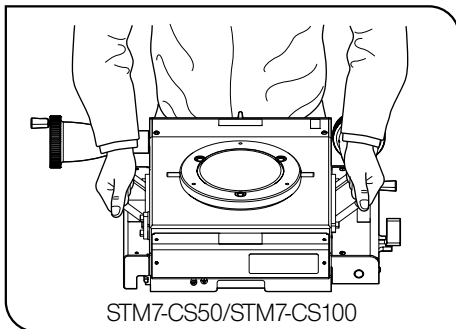
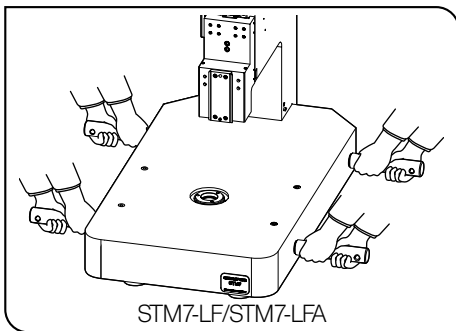

◎ Weight of each unit: 51.8 kg (STM7-SF), 53.8 kg (STM7-SFA), 77.1 kg (STM7-MF), 78.6 kg (STM7-MFA)

◎ Weight applied on one transport stick:

	Front transport stick of the frame	Back transport stick of the frame
STM7-SF	Approx. 1 kg	Approx. 25 kg
STM7-SFA	Approx. 1 kg	Approx. 26 kg
STM7-MF	Approx. 10.1 kg	Approx. 28.4 kg
STM7-MFA	Approx. 10.3 kg	Approx. 29 kg

4. Carry the frame STM7-LF/STM7-LFA using the transport sticks with both hands.

◎ Weight of each unit: 150.5 kg (STM7-LF), 152 kg (STM7-LFA)

◎ Weight applied on one transport stick:

	Front transport stick of the frame	Back transport stick of the frame
STM7-LF	Approx. 33.6 kg	Approx. 41.6 kg
STM7-LFA	Approx. 34 kg	Approx. 42 kg

CAUTION • To prevent malfunction, hold the stage only by the transport rod or the transport sticks.

• Be sure to detach the stage, observation tube, reflected light arm and digital indicator before carrying the frame. If you hold parts other than the frame, the product may be damaged.

5. Carry the stage STM7-CS50/STM7-CS100 using the transport rods with both hands.

◎ Weight of each unit: 18.1 kg (STM7-CS50), 17.7 kg (STM7-CS100)

◎ Weight applied on one transport rod: Approx. 9 kg (STM7-CS50), Approx. 8.9 kg (STM7-CS100)

6. Carry the stage STM7-CS200/STM7-CS300 using the transport sticks.

◎ Weight of each unit: 59.8 kg (STM7-CS200), 111.3 kg (STM7-CS300)

◎ Weight applied on one transport stick: Approx. 15 kg (STM7-CS200), Approx. 27.8 kg (STM7-CS300)

7. Be sure to check the equipment before use.

Particularly, prior to using the stage, check the stage by moving it slowly making one reciprocation back and forth and from side to side over the entire movable area.

Doing so will spread the grease at the guide area over the entire stage to keep the stage operations in a good condition for a long time.

8. Do not touch the connector pins of modules with your hands directly.

The modules may be damaged by static.

9. To perform the measurement as accurately as possible, warm up the equipment for about one hour (Z-axis manual type) or about two hours (Z-axis motorized type) after turning ON the powers of all units until starting the measurement.

10. With the Z-axis motorized type model, be sure to set the lower software limit in order to prevent collision between the objective and measuring object (page 32).

11. With the Z-axis manual type model, do not rotate fine focusing knobs by holding both right and left fine focusing knobs **a** as shown in the left picture. Otherwise, the fine focusing knob may come off. If it comes off, contact Evident.

12. Do not operate the clutch lever of the stage while it is moving (page 36). Otherwise, accuracy deterioration or damage may result.
13. To maintain accuracy, it is recommended that the microscope undergoes the Evident periodic inspection service (accuracy inspection, calibration, functional check, etc.) once a year. It is recommended that the microscope also undergoes this service when the microscope has been reinstalled at a different location. (Note that this service is subject to charge.)
14. In case of emergency, unplug the power cord to stop supplying electricity.
Install the microscope at a location where you can reach the power cord connector (rear of the control box) or the outlet at hand to disconnect the power cord.
15. The basic software (STM7-BSW) can also be used with the measuring microscope STM6 (with some restrictions).
16. The hardware of STM6 is not compatible with the hardware of STM7. If modules other than modules described in this instruction manual are connected to the microscope, the system may be damaged.

Emergency stop switch

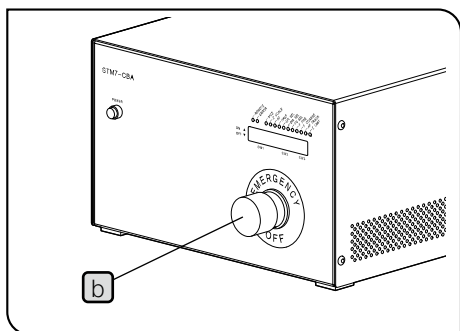

1. The emergency stop switch **b** on the control box for motorized STM7-CBA forces the Z-axis movement to stop. (motorized frame only)
In case of emergency, press the emergency stop switch.
2. To release the switch, rotate the emergency stop switch in the resetting direction (clockwise), and then rotate the fine/coarse focusing knob of the focus controller STM7-MCZ to move the focusing unit to the safe position.
Then, set the main switch of the control box for motorized to "OFF" (OFF), and set the main switch of the control box for motorized to "ON" (ON) again.
When the main switch is set to "ON" (ON), five short beeps indicating an error are generated. (When using the digital indicator STM7-DI, the display shows "013F1507". To cancel this error, operate either the FOCUS buttons ▲▼ or the fine/coarse focusing knob of the focus controller to move the Z-axis by 50 μm or more and set the main switch to "OFF" (OFF) and then to "ON" (ON).
3. If the emergency stop switch is pressed during the origin search, you cannot move the focusing unit even though the emergency stop switch is rotated to the resetting direction.
To cancel this, while the emergency stop switch is rotated to the resetting direction, set the main switch of the control box for motorized to "OFF" (OFF) and then set the main switch to "ON" (ON) again. When the error sound (five short beeps) is heard (If you are using the digital indicator STM7-DI, "013F1507" is displayed on the display area.), cancel the error according to the procedures in 2.

Height Measurement

1. To measure the height with higher accuracy, use an objective with high magnification. (50x or higher)

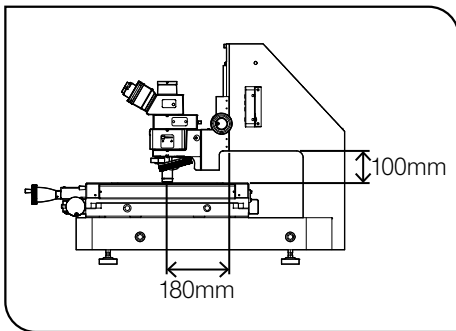

2. When measuring the height using the autofocus unit, the focusing unit rises by AF operation. Therefore, the focusing unit may stop rising because the focusing unit reaches the upper limit of its movable area.
3. When using the MM6-OB10X, the objective may collide with the stage before the focusing unit reaches the lower limit of the Z-axis movable area. Therefore, operate it with careful attention.
4. When using the objective with a working distance less than 5 mm in combination with the rotatable stage, the objective may collide with the stage before the focusing unit reaches the upper limit of the Z-axis movable area. Therefore, set the lower software limit and operate it carefully.
5. When using the rotatable stages STM7-RS100/STM7-RS200/STM7-RS300, the Z measurement range will be narrower by the amount of the rotatable stage height. (30 mm)
6. When using the large frame STM7-LF/STM7-LFA, a specimen whose height is 100 mm or less can be placed at the position backward from the light axis by 180 mm or more.

Stage

1. The Y-axis knob of the 50x50 mm stage STM7-CS50 or the 100x100 mm stage STM7-CS100 comes out below the stage-mounting surface.
When placing the stage on the table, etc., avoid the Y-axis knob from contacting the table surface.
2. When you purchase a new stage or replace/repair the stage, input the setting values suitable for the stage again (page 74).
3. When you move the stage by releasing the clutch, hold the movement knob. (Do not apply the excess load to the X- or Y-axis knob.)

Adapter to mount measuring objectives

1. While MM6-OB1X is attached, do not attach/detach the adapter to mount measuring objectives to/from the microscope.
2. Do not attach the BD type of the UIS2 metallurgical objective to the adapter to mount measuring objectives.

Measurement objective

1. When the MM6-OB1X objective is used in reflected light illumination, spot-like flare may be observed on the center of measuring objects with low reflectance.

Hand switch

1. The hand switch is a module dedicated to the control box for manual STM7-CB. You cannot use this hand switch with the control box for motorized STM7-CBA.

Focus controller

1. The focus controller is a module dedicated to the control box for motorized STM7-CBA. You cannot use this focus controller with the control box for manual STM7-CB.
2. Do not rotate the fine/coarse focusing knobs on both sides in the reverse direction. They may be damaged.

3. When the coarse focusing knob is rotated, the fine focusing knob is rotated together with it. Do not stop rotating the fine focusing knob or rotate it in the reverse direction. Errors may be caused.

Controller

1. The controller data may become unexpectedly corrupted, so make frequent backups of your data.
2. Evident shall have no liability for any damage (including compensation for the corrupted controller data) from the use or misuse of this product.
3. Microsoft® Windows® has been installed on the controller of this system. Backup and keep the system data in a safe place (Evident does not provide support for backing up your system data). For more information about the controller and Microsoft® Windows®, refer to their corresponding manuals.
4. When themes other than standards are set on the Windows® desktop, the software window may not be displayed or printed properly.
5. The operations of the controller other than the controllers of which operations were confirmed are not ensured. For the controllers of which operations were confirmed, contact Evident.
6. If this system is used with connecting to the network, the data import may fail or the system could not be operated properly due to the automatic update of the operating system, etc. Disable the automatic update of the operating system, etc. before use. If you update the operating system, etc. confirm the condition of this system in advance.
7. If a virus search, sleep or the screen saver is activated while the system is operating, data import could fail and the system operation could become unstable. Disable an automatic virus search, sleep and the screen saver (these functions have been disabled when the basic software is installed).
8. The system does not support to change the location of the controller. (Use the operating system with the factory default language: Japanese or English.)

Basic software/MIA, EFI option software

- ☉ Refer to the instruction manual provided with the basic software/MIA, EFI option software.

Excel transfer tool

1. The Excel transfer tool and the basic software can be installed to the same controller, but they cannot be used at the same time.
2. The Excel transfer tool cannot be used with STM6.

Focus navigator unit

1. The focus navigator unit cannot be used together with the autofocus unit STM7-AF.
2. The objectives compatible with this unit are the 10X to 50X objectives.

3. Focusing is possible on specimens with reflectance of glass to mirror. However, it is difficult for the reticle to be able to be seen with the specimens with very irregular surface (surface of a plastic mold, etc.)
4. The brightness of the reticles both top and bottom might be varied. However, there is not a problem in case of use.
5. The reticle might shift from center of the eyepiece. However, there is no problem in case of use.
6. According to the combination of the light source, there is a difference in the light of the reticle. However, there is no problem in case of use.
7. Contact lens wearer have the possibility to influence the focusing repeatability. The naked eye is recommended.
8. Depending on the specimen, the reticle may be visible even in an out-of-focus position. So be careful.
9. When this unit is installed, it may affect the observations as described below.
 - When this unit is combined, the periphery of the observation field of view may become dark. If this bothers you, replace the cross-frame part of the eyepiece with that provided with this unit (page 34).
 - Because the observation luminous energies decreases with this unit, the reflected light DIC observation cannot be used.

Rotatable stage

1. Do not attach the rotatable stage on the stage by reversing front and back, right and left, and up and down.
2. Use the fine focusing knob (lower right area of the stage top surface) to rotate the rotatable stage. Do not rotate the rotatable stage with your hands.
3. Do not rotate the fine focusing knob when the rotatable area is fixed.
4. During carrying the rotatable stage, tighten the rotation clamp knob (lower left area on the stage top surface) to secure the rotatable area.
5. When carrying the rotatable stage, hold it by putting your hand on the groove on the side surface of the base of the rotatable stage. Do not hold any other parts.

Camera

1. Use the USB cable provided with the digital camera.
2. STM7-CU: Do not connect to ports other than the USB 2.0 port complied with ENCI (Enhanced Host Controller Interface) standard of the controller. Otherwise, the operations are not ensured.
3. If the digital camera is used in a high temperature environment, the noise on the image will be increased.
4. Using the camera will increase the load on the controller. The longer the camera exposure time is, the slower the frame rate and the application operations become.
(When using the microscope digital camera, refer to the instruction manual provided with DP22/DP23/DP27/DP28.)

5. The frame rate (reference) is shown in the table below when the microscope digital camera DP23-CU/DP28-CU and the basic software STM7-BSW are combined.

Camera	Resolution	Frame rate (reference)[fps]
DP23-CU	3088 x 2076	25
DP28-CU	4104 x 2174	15

Autofocus unit

- ☉ Refer to the instruction manual provided with the autofocus unit.

Control box

- ☉ Refer to the instruction manual provided with the control box.

Repair and movement of the system

1. The assembly and setup are performed by the Evident dealer. Do not repair or move the microscope by yourself. If you want to move the microscope, consult an Evident sales office. If repairing or moving the microscope by you should cause the microscope to malfunction or be damaged, Evident shall not be liable for the consequence. Even if the consequence occurs during the warranty period, the service may have to be chargeable.
2. Do not carry the microscope without the dedicated transport tools or packaging materials. Otherwise, the accuracy is not ensured.
 - Be sure to carry the microscope carefully only by those who understand the transportation cautions (described in the instruction manual).
 - Those who install the microscope must read the descriptions in the instruction manual and understand the installation procedures.
3. When transporting the STM7, be sure to use the dedicated transporting tools and packing materials. Consult your local Evident representative for details.
4. When transporting, be sure to use the Z-axis transport lock and clamps/screws. Even though the clutch of the stage is fixed, if the stage is tilted significantly, the stage will be moved, which is very dangerous.
5. Relocating the microscope overseas by you without notifying Evident in advance will not allow you to enjoy the service in the country where the microscope was relocated.
6. If you relocate the microscope overseas, note the following matters:
 - The power cords must be replaced with ones that can be used in your destination.
 - Confirm that the device is conformed to the laws and regulations of the relocation destination.
 - Some countries and regions have not established the Evident service system. Contact Evident for details.
 - Not all the countries and regions with the Evident service system provide their after-sales services under the same conditions as those in your country.

Certificate of Accuracy

1. Do not lose Certificate of Accuracy. The setting values of factory default values (accuracy assurance) are described in Certificate of Accuracy.

Maintenance and storage

1. Do not leave stains or fingerprints on the lenses. If they get dirty, blow away dust with a commercially available blower and gently wipe the lens or filter with a piece of cleaning paper (or clean gauze).

For cleaning fingerprints and oil stains, slightly moisten a piece of cleaning paper with commercially available absolute alcohol and wipe them off with it.



CAUTION

Since the absolute alcohol is highly flammable, it must be handled carefully. Be sure to keep it away from open flames or potential sources of electrical sparks – for example, electrical equipment that is being switched on or off, which could cause ignition of a fire. Also, remember to always use absolute alcohol only in a well-ventilated room.

2. Do not use organic solvents, which cause painted and plastic parts to deteriorate. Do not use organic solvents to clean device components other than the glass components. To clean them, use a lint-free, soft cloth slightly moistened with a diluted neutral detergent.
3. When cleaning the base unit of the frame, use the cleaner dedicated to the stone surface plate.
4. After use, return the stage to the center position and lock the clutch to maintain the stage accuracy. And do not place a heavy object on the stage.
5. After using the system, set the main switch to "●" (OFF), wait for the control box and power supply unit to cool down sufficiently, and keep it covered with a dust cover during storage.
Recommended cover (Option): COVER-022
6. After using the system, return the stage to the center position and fix the clutch levers. Do not place a heavy object on the stage.
7. Avoid using or storing the equipment under direct sunlight, high temperature (over 40 °C), high humidity, excessive dust or vibrations.
8. Do not bend extremely, pull or step on the cables. Also take special care in its distribution.
9. Never oil the XYZ guide **a**.
10. Before disposing of this product, be sure to follow the regulations and rules of your local government.

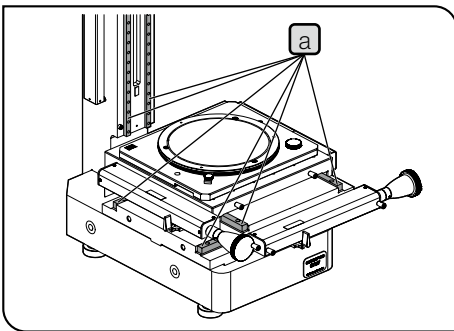

1 Nomenclature of module

- ◎ The modules shown below are only the basic modules. As there are other modules which can be combined with the microscope but are not shown below, please also refer to the latest Evident brochures or your dealer. For information on the modules marked with “*”, refer to their instruction manuals.

Manual frame
STM7-SF/STM7-MF/STM7-LF

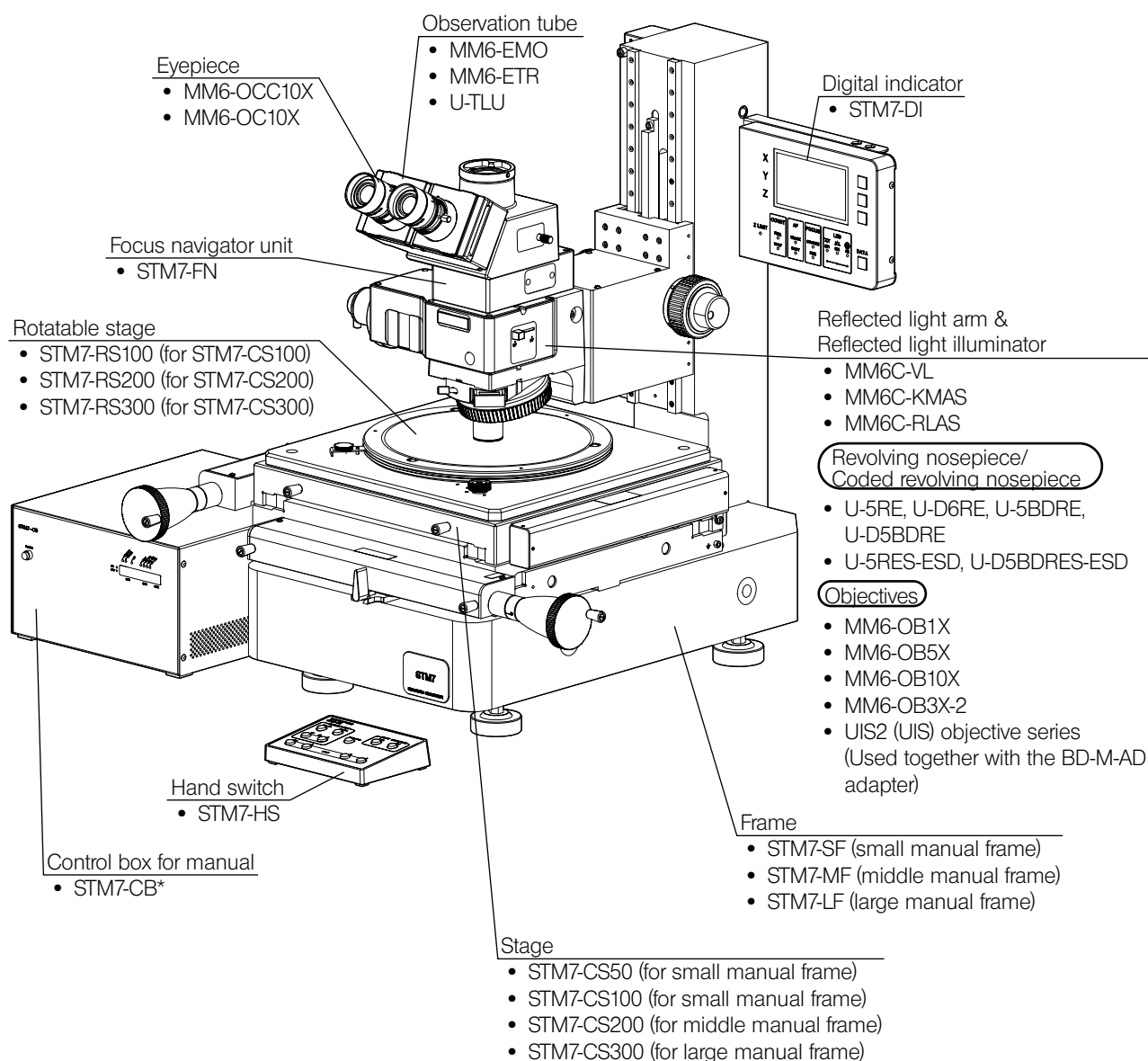

STM7-SF, STM7-MF and STM7-LF are categorized as optical microscope, other products are categorized as optical microscope accessory.

Motorized frame
STM7-SFA/STM7-MFA/STM7-LFA

- ⊙ The modules except those described here are same as the manual frame.
For information on the modules marked with “*”, refer to their instruction manuals.

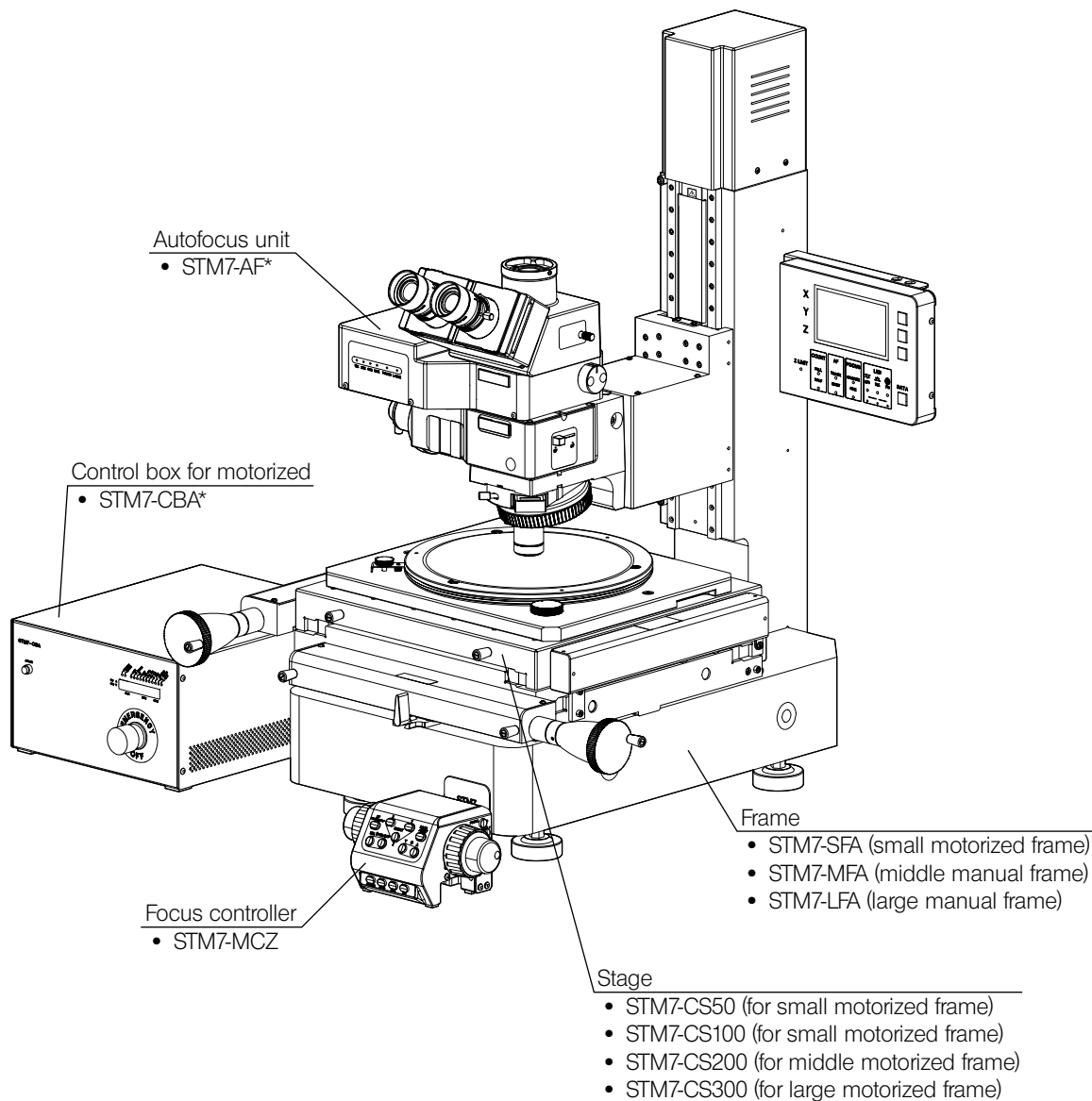

- ⊙ Either the focus navigator unit STM7-FN or the autofocus unit STM7-AF can be combined with the motorized frame.

Option

- Foot switch STM7-FS
- Digital camera STM7-CU
- Eyepoint adjuster U-EPA2

STM7-SFA, STM7-MFA and STM7-LFA are categorized as optical microscope, other products are categorized as optical microscope accessory.

2 Nomenclature of operating portions

Manual frame
STM7-SF/STM7-MF/STM7-LF

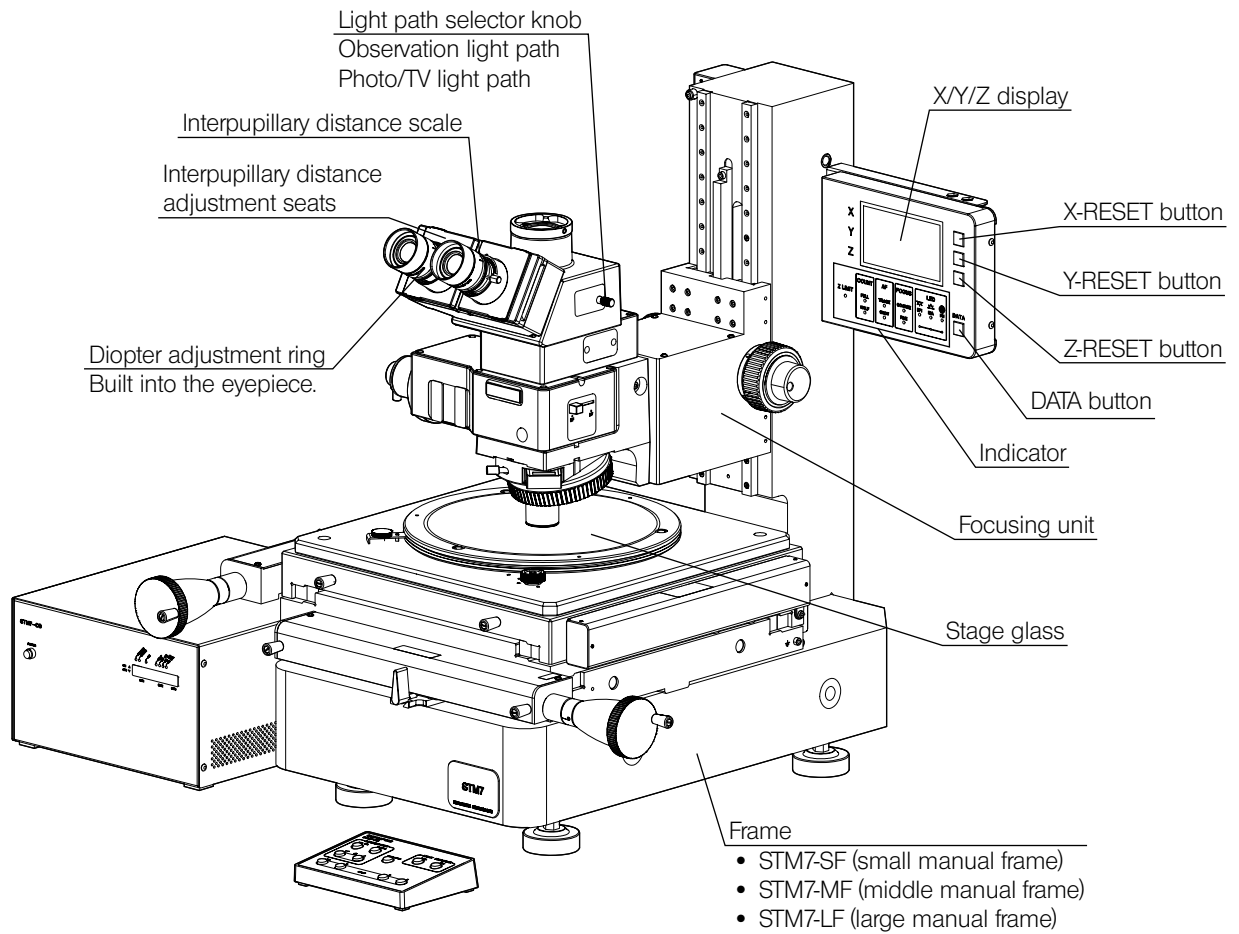

Motorized frame
 STM7-SFA/STM7-MFA/STM7-LFA

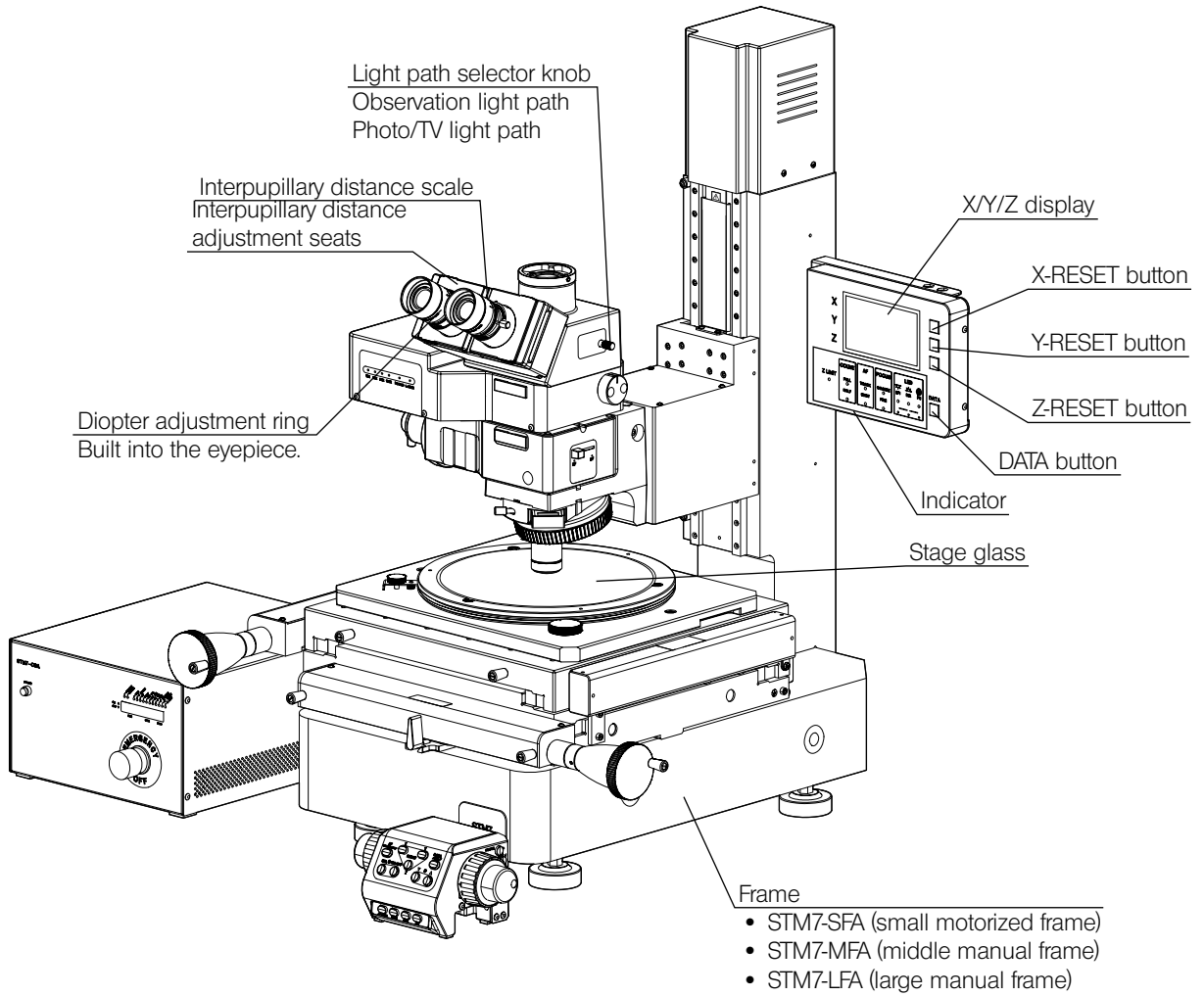

Stage
STM7-CS50/STM7-CS100/
STM7-CS200/STM7-CS300

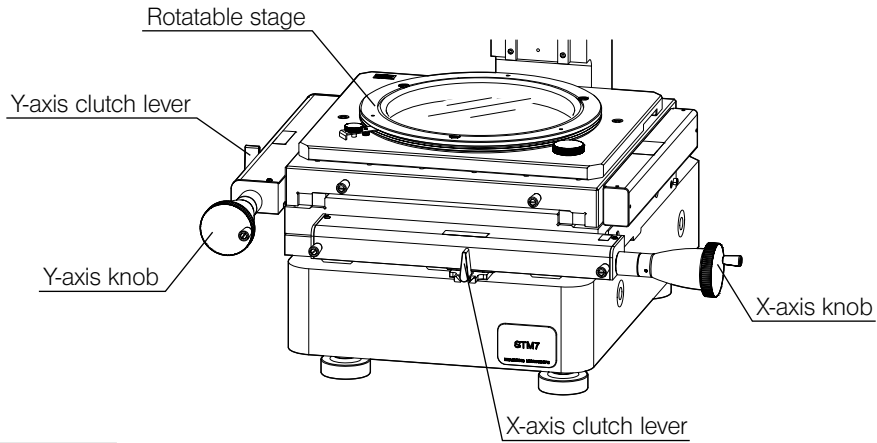

Control box
STM7-CB/STM7-CBA

⊙ The names of operating portions of the control box for motorized STM7-CBA are illustrated below. The names of the operating portions of the control box for manual STM7-CB are same.

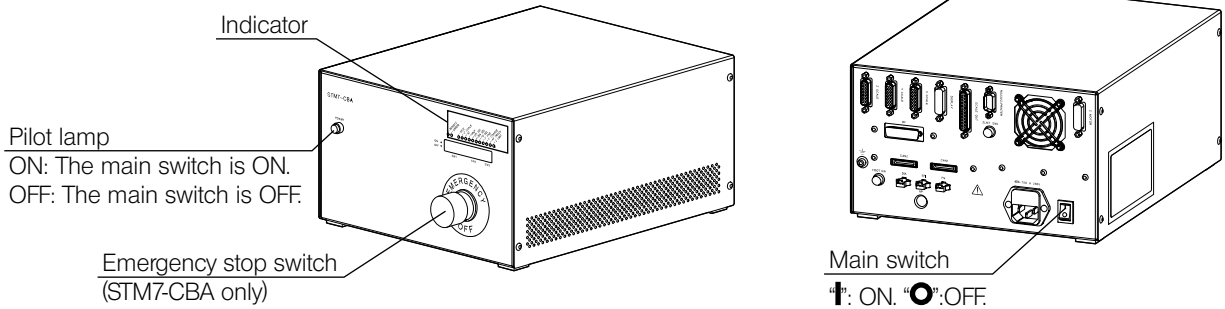

Hand switch
STM7-HS

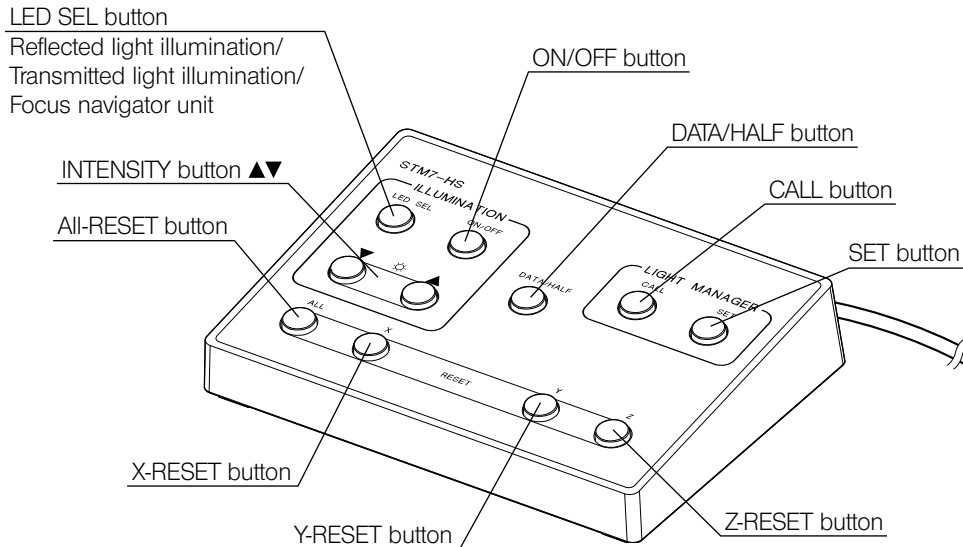

Focus controller
STM7-MCZ

* This does not work unless the autofocus unit STM7-AF is connected.

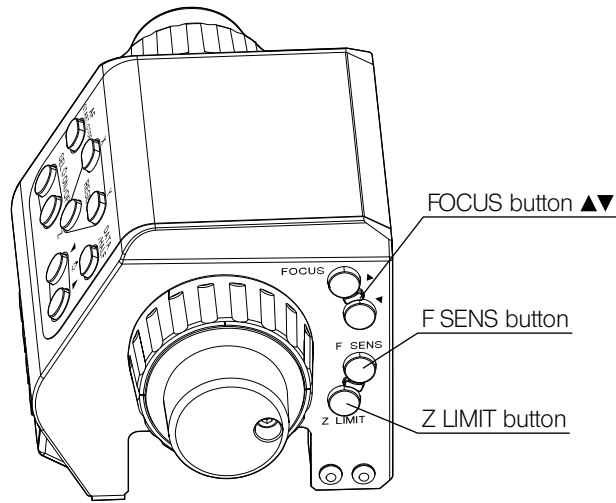
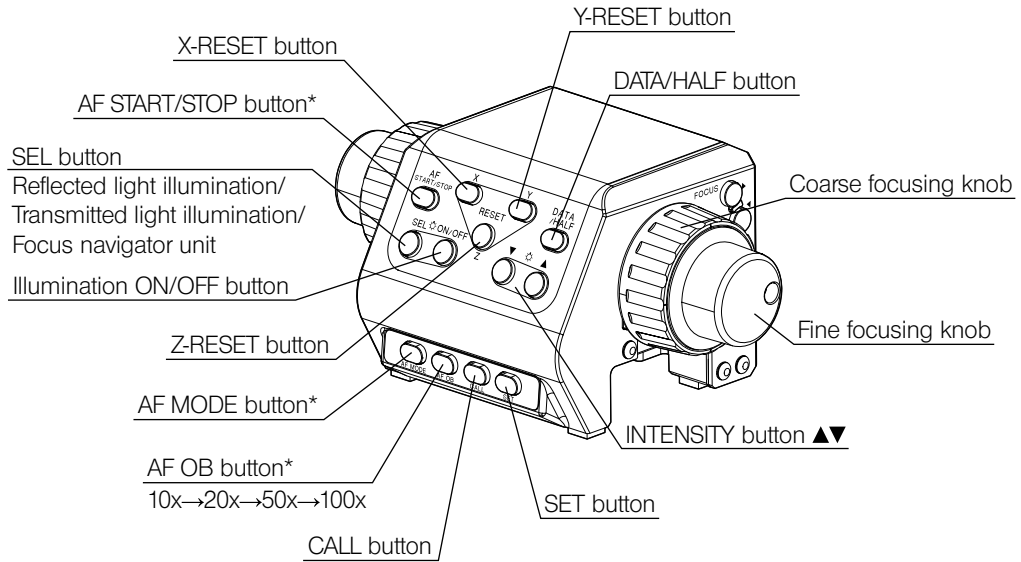

Brightfield reflected light arm
MM6C-VL

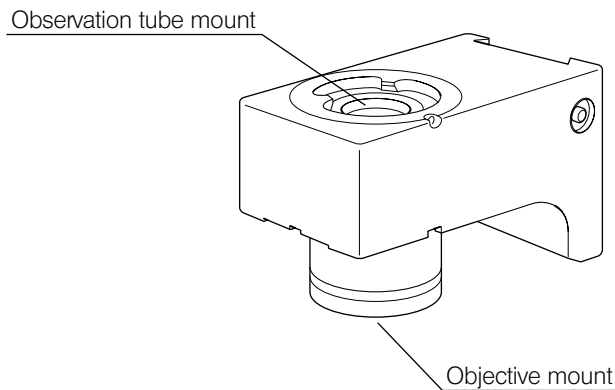

Brightfield reflected light illuminator
MM6C-KMAS

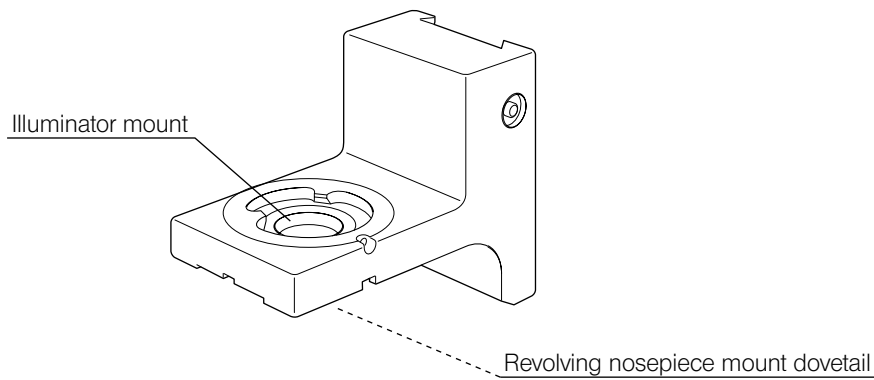
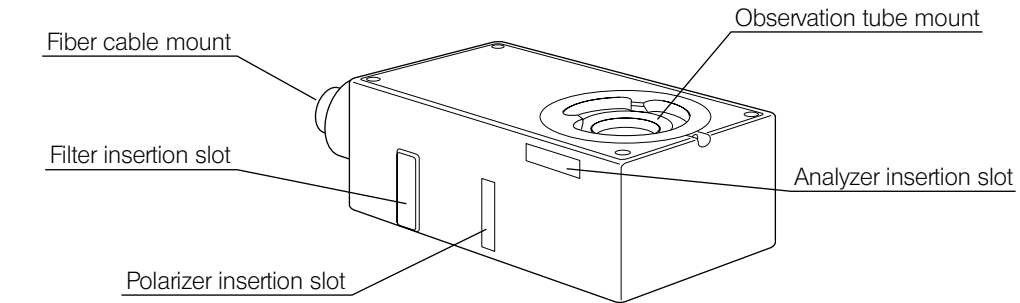

Brightfield/Darkfield reflected light illuminator
MM6C-RLAS

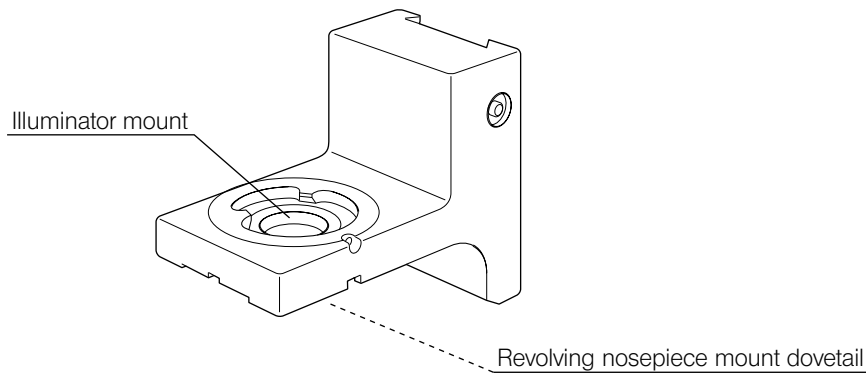
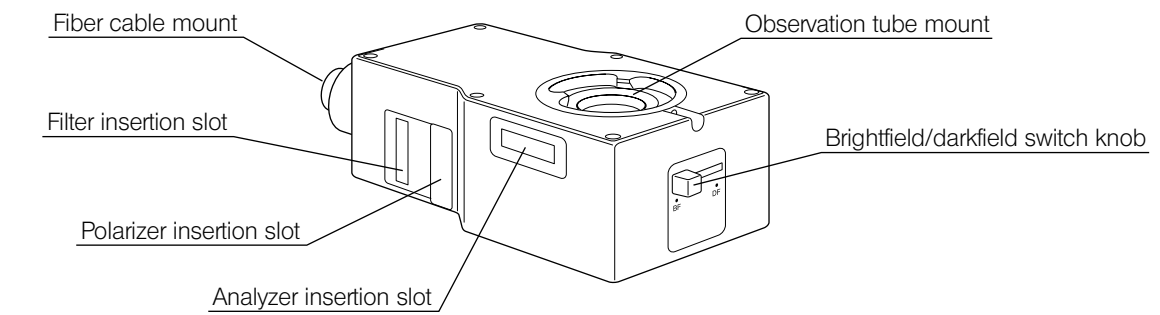

Power supply unit
MM6-ILPS-2

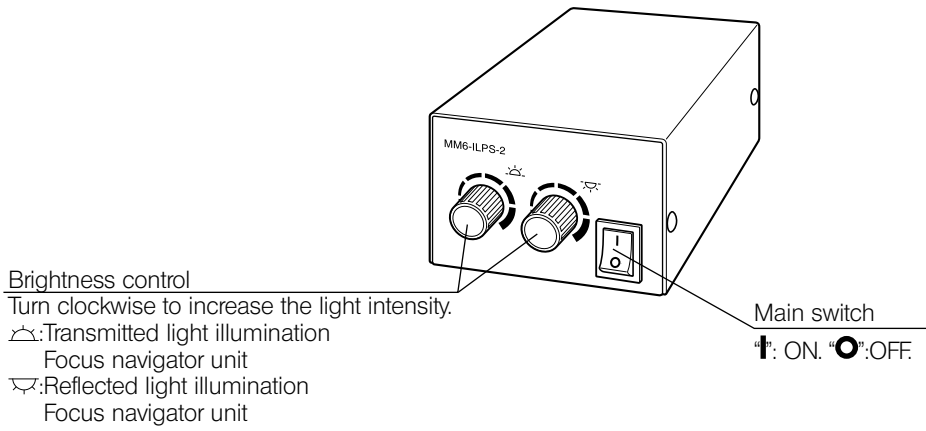

Focus navigator unit
STM7-FN

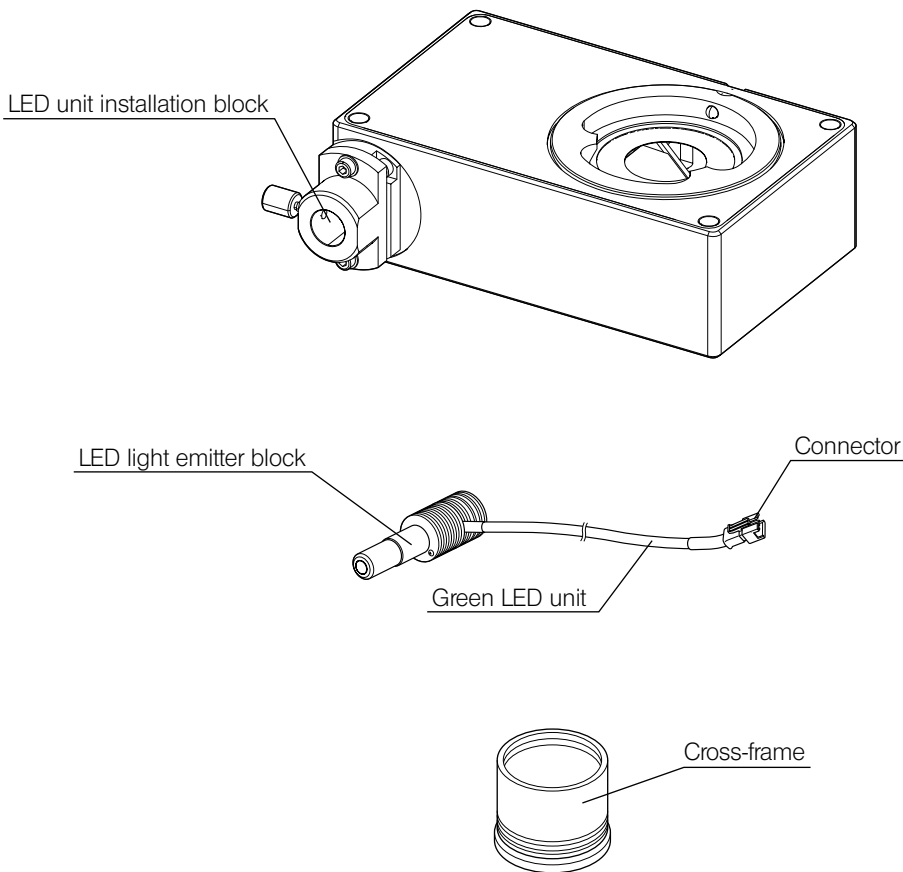

Autofocus unit
STM7-AF

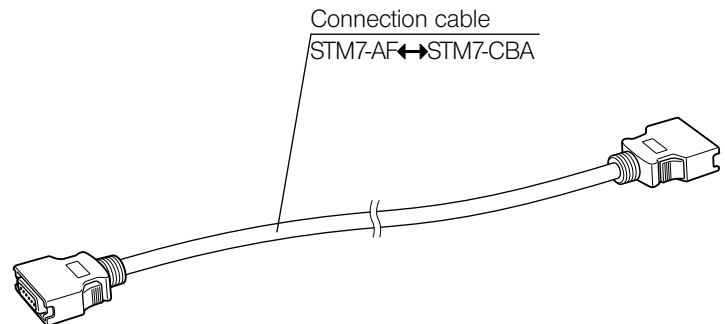
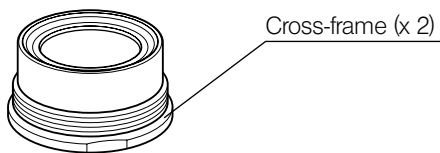
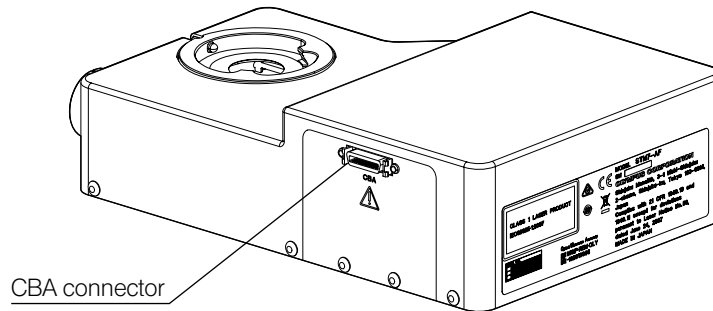
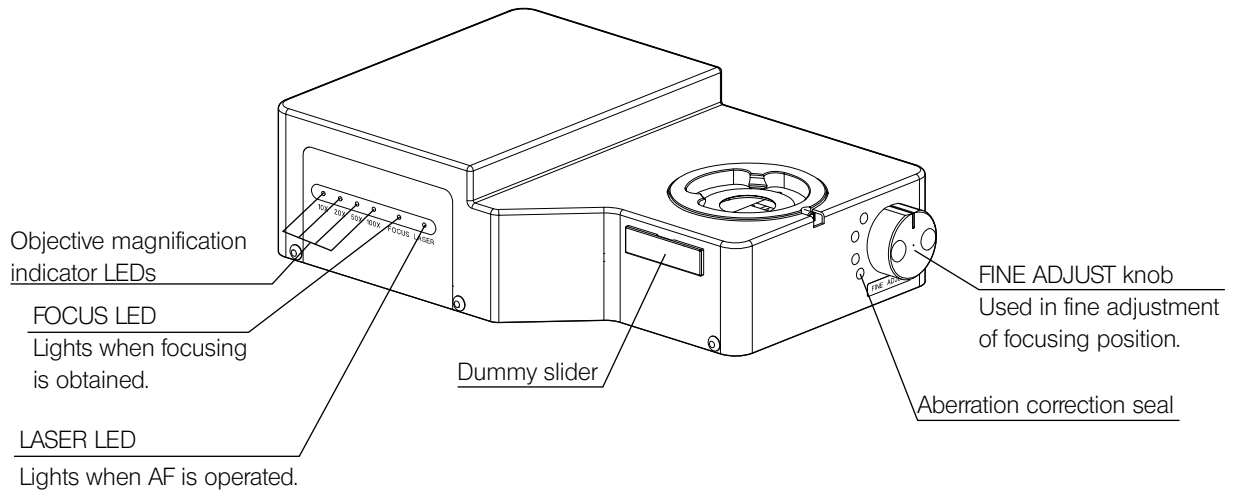

3 Operation procedures

© The operation procedures are illustrated in combination with the middle manual frame as a reference. Unless otherwise specified, the same applies to other combinations.

3-1 Turning Power ON

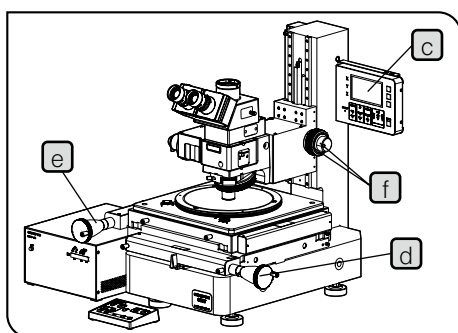
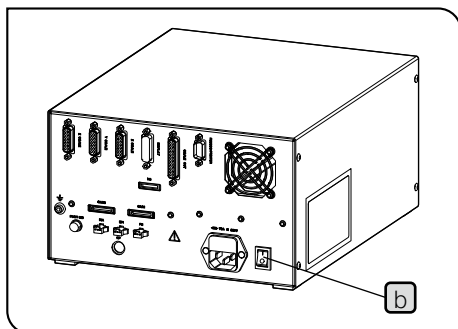
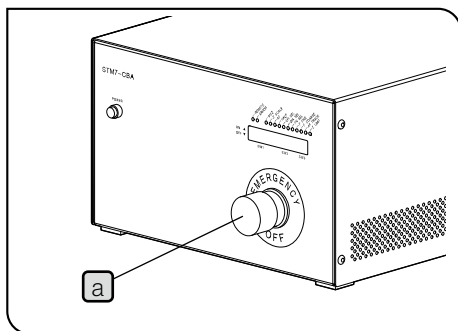

1 Functioning of Modules

CAUTION Confirm followings before turning ON the power.

- Ensure that the connection cables and the power cords of the control box and power supply unit are connected properly.
- When the origin search is set to ON, if the power of the control box for motorized STM7-CBA is turned ON, be careful the focusing unit moves upward. (Motorized frame only) For the origin search setting, refer to page 51.
- Rotate the emergency stop switch **a** on the control box for motorized STM7-CBA in the resetting direction (clockwise) to ensure that the switch is not set to ON. (Motorized frame only) If the emergency stop switch is ON, refer to page 7 and restore it.

1 Set the main switch **b** on the rear of the control box STM7-CB/STM7-CBA to **I** (ON). (Only when using the control box.)

2 Set the main switches of the modules you are using to **I** (ON). (For details, refer to the instruction manual provided with each module.)

3 Confirm that the LED illuminator is turned ON by using the light intensity control function of the hand switch STM7-HS or the focus controller STM7-MCZ.

For details, refer to "3-3 Hand switch (Manual frame only)" (page 25) or "3-4 Focus controller (Motorized frame only)" (page 28).

4 The display **c** on the digital indicator should be illuminated now. Rotate the X-axis knob **d**, the Y-axis knob **e**, the fine/coarse focusing knob **f** or the fine/coarse focusing knob of the focus controller STM7-MCZ to make sure that the display on the digital indicator shows counting.

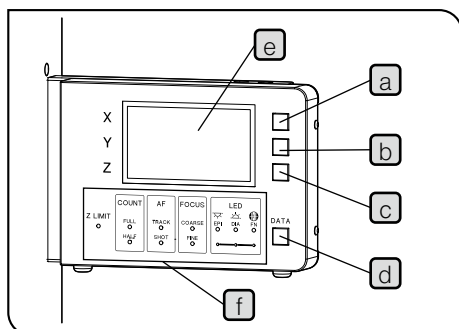

2 X/Y/Z display

Digital indicator STM7-DI

- a** X-RESET button: Resets the X-axis counter.
- b** Y-RESET button: Resets the Y-axis counter.
- c** Z-RESET button: Resets the Z-axis counter.
- d** DATA button: When this button is pressed, the count data being shown in the display **e** is output to the controller, data processing device or printer which is connected to the RS-232C connector.
- f** Indicator: Confirms whether or not the lower software limit is set, whether or not the counter data is displayed in-half, AF mode (motorized frame only), movement distance of the fine/coarse focusing knob (motorized frame only), illumination ON/OFF and the illumination to be controlled.

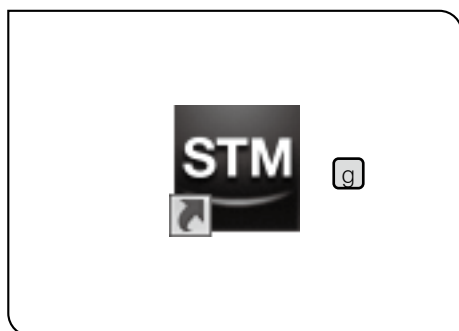

Excel transfer tool

When this software is installed to the controller, the counter data can be confirmed by the controller.

This software can be started by double-clicking the [Excel Transfer Tool] icon **g** on the desktop.

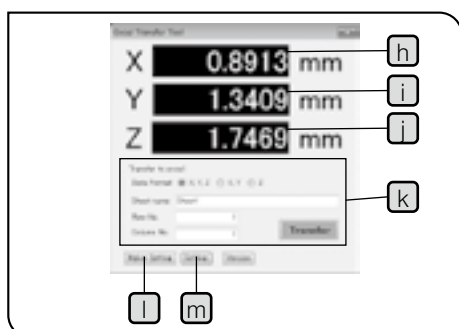

- h** X-axis counter
- i** Y-axis counter
- j** Z-axis counter
- k** Transfer to Excel : Transfers the counter data of X-, Y- and Z-axis to Microsoft® Office Excel®.
- l** Maker setting mode : Sets the microscope.
(Ask Evident to set the microscope.)
- m** Setting : Sets the Excel transfer tool.

© For details, refer to Help of Excel transfer tool.

3-2 Focusing unit (Manual frame only)

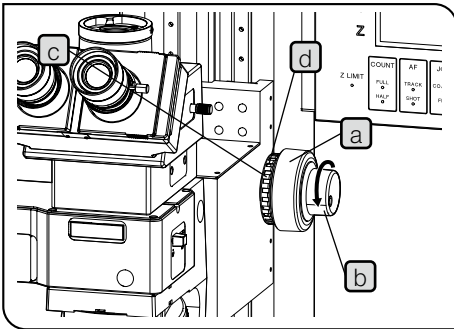

1 Focusing operation

The focusing unit is designed to be lowered (approaching the objective with the specimen) when the coarse focusing knob **a** or fine focusing knob **b** is turned in the direction of the arrow.

2 Adjusting the coarse focusing knob tension

The tension of the coarse focusing knob is adjustable. Turn the rotation tension adjustment ring **c** in the direction of the arrow to decrease the knob's tension and in the opposite direction to increase it.

- ⊙ If the focusing unit lowers by its own weight or the focus obtained with the fine focusing knob **b** is lost soon, the tension is set too loose. In this case, turn the rotation tension adjustment ring **c** clockwise (opposite direction of the arrow) to increase the tension.
- ⊙ If it is difficult to rotate the rotation tension adjustment ring, insert the Allen screwdriver provided with the frame into the hole **d** (either one of 4 holes) of the adjustment ring and rotate the rotation tension adjustment ring.

CAUTION Do not use any tool other than the Allen screwdriver provided with the frame. Otherwise, the failure may be caused.

3-3 Hand switch (Manual frame only)

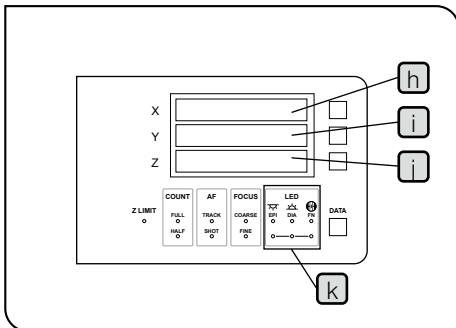
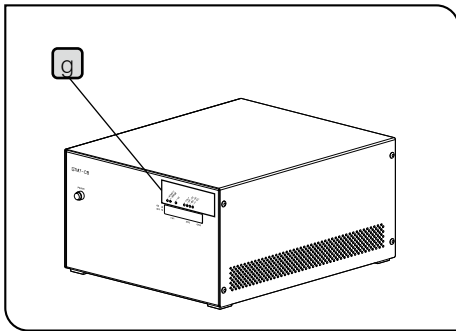
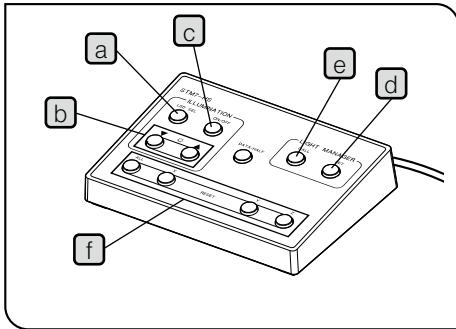

1 Controlling illumination

Selecting illumination

Press the LED SEL button **a** to select the illumination you want to control. (Reflected light illumination/transmitted light illumination/focus navigator unit)

- ⊙ The illumination selected can be confirmed with the indicator **g** of the control box for manual STM7-CB or the display X **h** of the digital indicator STM7-DI or the LED **k**.

	Reflected light illumination: selected	Transmitted light illumination: selected	Focus navigator unit: selected
STM7-CB (Always displayed)			
Display X of STM7-DI (Displayed for a specified time)			
LED of STM7-DI (Always displayed)			

Controlling light intensity

Press the INTENSITY button **b** to control the illumination intensity.

- ▲: Brighter
- ▼: Darker

- ⊙ If the INTENSITY button is pressed, the light intensity value is displayed on the display Z **i** for a specified time.
- ⊙ If the INTENSITY button is kept pressed, the light intensity control interval is increased.

Illumination ON/OFF

Press the ON/OFF button **c** to turn ON/OFF the selected illumination.

- ⊙ The illumination ON/OFF status can be confirmed with the display Y **i** of the digital indicator STM7-DI or the LED **k**.

	Reflected light illumination: ON	Transmitted light illumination: ON	Focus navigator unit: ON
Display Y of STM7-DI (Displayed for a specified time)			
LED of STM7-DI (Always displayed)			

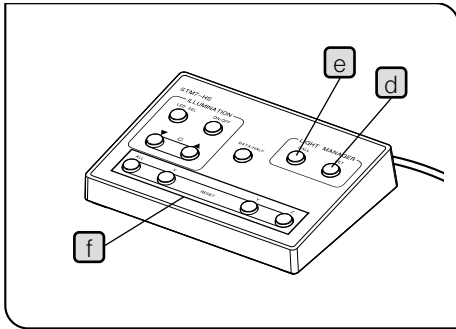

Memorizing light intensity value

Keep pressing the SET button **d** until the buzzer beeps and memorize the current light intensity value of each illumination to the microscope. (Reflected light illumination/transmitted light illumination/focus navigator unit)

- Ⓢ When using the manual revolving nosepiece, the light intensity values of one set (reflected light illumination/transmitted light illumination/focus navigator unit) can be memorized. When using the coded revolving nosepiece, the light intensity values of up to five sets can be memorized according to the number of holes.

Loading light intensity value

Press the CALL button **e** to load the light intensity value in which each illumination is memorized.

2 Resetting counter data of X-, Y- and Z-axis

Among RESET buttons **f**, press the ALL-RESET button to reset all counter data of X-, Y- and Z-axis to zero.

Press the X-RESET, Y-RESET or Z-RESET button to reset the counter data of X-, Y- and Z-axis.

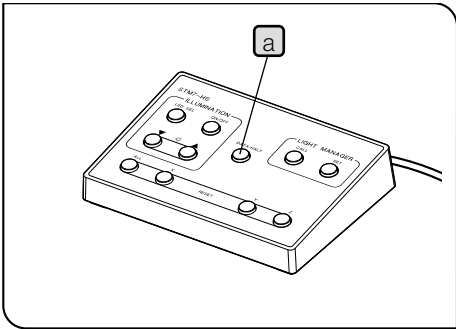

3 Outputting counter data of X-, Y- and Z-axis

Press the DATA/HALF button **a** to output the data to the controller, the data processing device or the printer connected to the RS-232C connector.

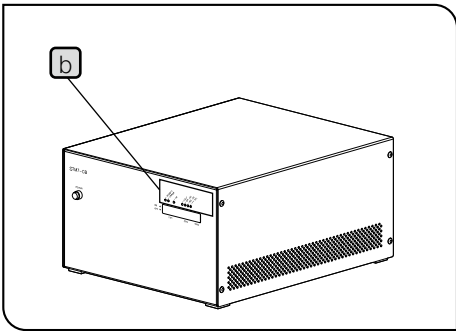

4 Counting counter data of X-, Y- and Z-axis in-half

When keeping the DATA/HALF button **a** pressed for 3 seconds or longer, the counter data of the X-, Y- and Z-axis will be displayed in half of the actual movement values. (The value displayed when the button is pressed is held in memory)

When keeping the DATA/HALF button pressed further again, the count-in-half function is turned OFF. (The value displayed at this time is also held in memory)

☉ The ON/OFF of the count-in-half function can be confirmed with the indicator **b** of the control box for manual STM7-CB or the display X **c** of the digital indicator STM7-DI or the COUNT **d**

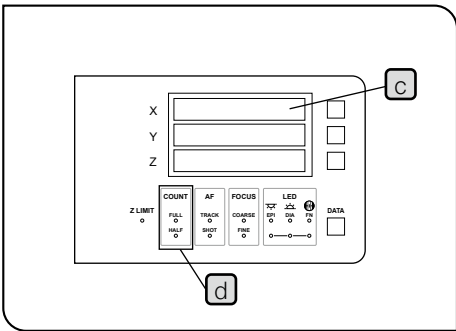

	Count-in-half function: ON	Count-in-half function: OFF
STM7-CB (Always displayed)		
Display X of STM7-DI (Displayed for a specified time)		
COUNT of STM7-DI (Always displayed)		

3-4 Focus controller (Motorized frame only)

© For AF operations with the autofocus unit STM7-AF, see "3-9 Autofocus unit (Motorized frame only)"(page 39).

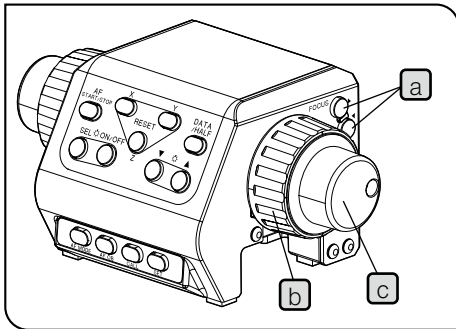

1 Z-axis coarse focusing

The coarse focusing in the Z-axis direction is available with the FOCUS buttons **a**. Holding a button continuously increases the movement speed (up to 8 mm/sec).

CAUTION When moving the Z-axis, do not touch around the focusing unit. Your hands or fingers may be pinched between the focusing unit and the focusing unit opening or the stopper.

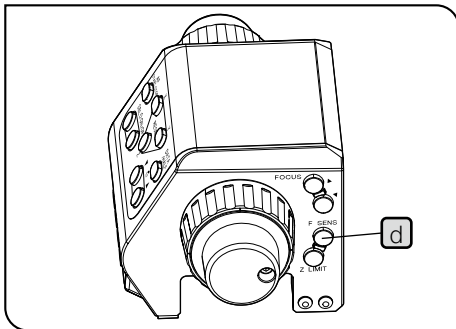

2 Z-axis fine/coarse adjustment with fine/coarse focusing knob

© When rotating the coarse focusing knob **b** or the fine focusing knob **c** for one turn, the movement distance in the Z direction can be selected.

Movement distance adjustment

The movement distance of the coarse focusing knob **b** and the fine focusing knob **c** are changed every time the F SENS button **d** is pressed.

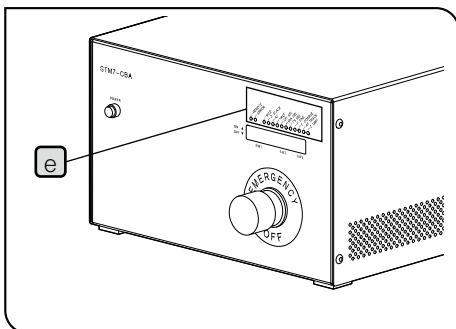

The movement distance can be confirmed by the indicator **e** of the control box for motorized STM7-CBA or the FOCUS **f** of the digital indicator STM7-DI.

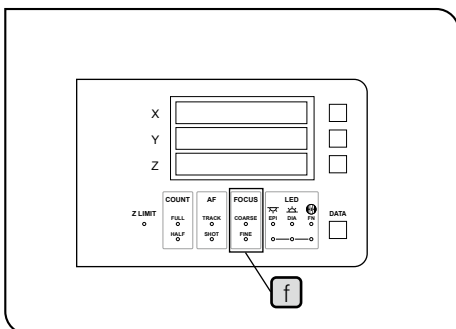

	Movement distance: Small		Movement distance: Large	
	Coarse focusing knob	Fine focusing knob	Coarse focusing knob	Fine focusing knob
Reference movement distance * (guide for per turn)	400 μm	50 μm	800 μm	100 μm
STM7-CBA				
FOCUS of STM7-DI				

* "Reference movement distance" is a reference value. Particularly, if the coarse focusing knob is rotated rapidly, the movement distance may be less than the reference movement distance.

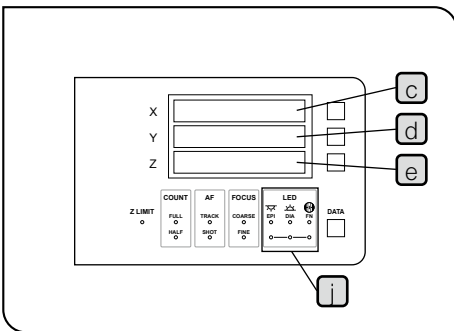
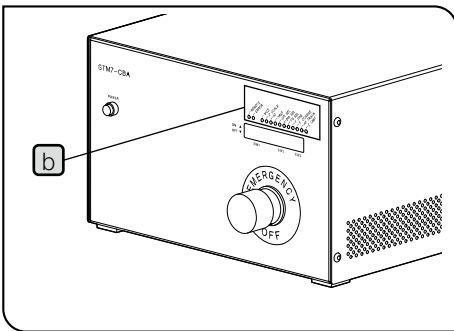
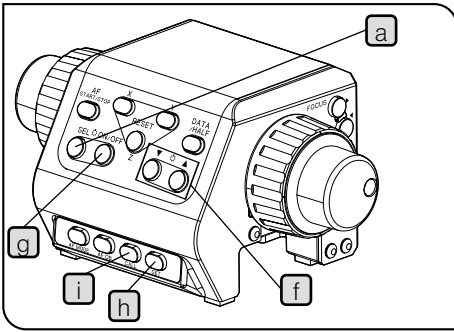

3 Controlling illumination

Selecting illumination

Press the SEL button **a** to select the illumination you want to control. (Reflected light illumination/transmitted light illumination/focus navigator unit)

- ☉ The illumination selected can be confirmed by the indicator **b** of the control box for motorized STM7-CBA or the display X **c** of the digital indicator STM7-DI or the LED **i**.

	Reflected light illumination: selected	Transmitted light illumination: selected	Focus navigator unit: selected
STM7-CBA (Always displayed)			
Display X of STM7-DI (Displayed for a specified time)			
LED of STM7-DI (Always displayed)			

Controlling light intensity

Press the INTENSITY button **f** to control the illumination intensity.

- ▲: Brighter
- ▼: Darker

- ☉ If the INTENSITY button is pressed, the light intensity value is displayed on the display Z **e** for a specified time.
- ☉ If the INTENSITY button is kept pressed, the light intensity control interval is increased.

Illumination ON/OFF

Press the ON/OFF button **g** to turn ON/OFF the selected illumination.

- ☉ The illumination ON/OFF status can be confirmed with the display Y **d** of the digital indicator STM7-DI or the LED **i**.

	Reflected light illumination: ON	Transmitted light illumination: ON	Focus navigator unit: ON
Display Y of STM7-DI (Displayed for a specified time)			
LED of STM7-DI (Always displayed)			

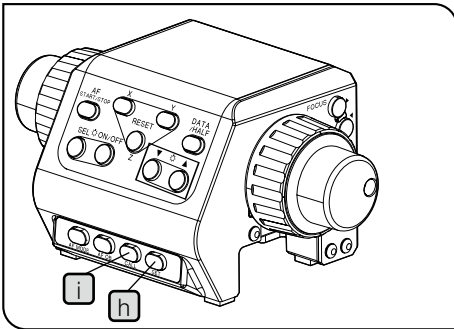

Memorizing light intensity value

Keep pressing the SET button **h** until the buzzer beeps and memorize the current light intensity value of each illumination to the microscope. (Reflected light illumination/transmitted light illumination/focus navigator unit)

- ⊙ When using the manual revolving nosepiece, the light intensity values of one set (reflected light illumination/transmitted light illumination/focus navigator unit) can be memorized. When using the coded revolving nosepiece, the light intensity values of up to five sets can be memorized according to the number of holes.

Loading light intensity value

Press the CALL button **i** to load the light intensity value in which each illumination is memorized.

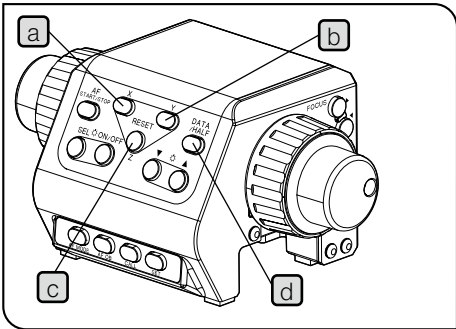

4 Resetting counter data of X-, Y- and Z-axis

Press the X-RESET **a**, Y-RESET **b** or Z-RESET **c** button to reset the counter data of X-, Y- and Z-axis.

5 Outputting counter data of X-, Y- and Z-axis

Press the DATA/HALF button **d** to output the data to the controller, the data processing device or the printer connected to the RS-232C connector.

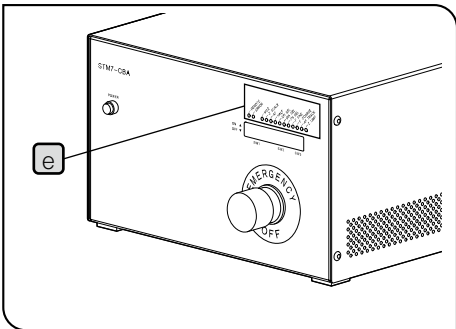

6 Counting counter data of X-, Y- and Z-axis in-half

When keeping the DATA/HALF button **d** pressed for 3 seconds or longer, the counter data of the X-, Y- and Z-axis is displayed in 1/2 value of the actual movement distance. (The value displayed when the button is pressed is held in memory)

When keeping the DATA/HALF button pressed further again, the count-in-half function is turned OFF. (The value displayed at this time is also held in memory)

- ⊙ The ON/OFF of the count-in-half function can be confirmed by the indicator **e** of the control box for motorized STM7-CBA or the display X **f** of the digital indicator STM7-DI or the COUNT **g**.

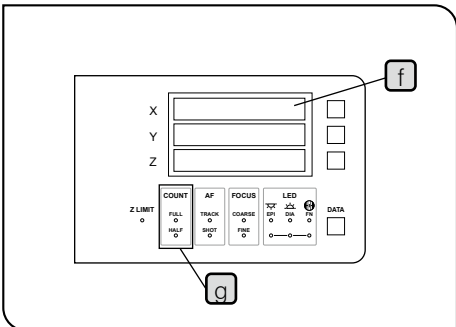

	Count-in-half function: ON	Count-in-half function: OFF
STM7-CBA (Always displayed)		
Display X of STM7-DI (Displayed for a specified time)	X	X
COUNT of STM7-DI (Always displayed)	Z LIMIT <input type="radio"/> COUNT <input type="radio"/> FULL <input type="radio"/> TRACK <input type="radio"/> COARSE <input type="radio"/> HALF <input checked="" type="radio"/> SHOT <input type="radio"/> FINE <input type="radio"/>	Z LIMIT <input type="radio"/> COUNT <input type="radio"/> FULL <input type="radio"/> TRACK <input type="radio"/> COARSE <input type="radio"/> HALF <input type="radio"/> SHOT <input type="radio"/> FINE <input type="radio"/>

7 Setting lower software limit

CAUTION In order to prevent collision between the objective and measuring object, be sure to set the lower software limit before using the microscope.

⊙ The current Z position can be set as the lower software limit.

This setting makes it possible to:

- avoid collision between an objective and specimen by preventing the Z position from being moved below the set limit by FOCUS ▼ button **a**, fine/coarse focusing knob **b** or autofocusing operation.
- produce three short beeps as the confirmation tone when the Z reaches the lower software limit.

Setting procedure

- 1 Lower the objective to the desired lower software limit position.
- 2 Keep pressing the Z LIMIT button **c** until the buzzer beeps. The [Z LIMIT] indicator **d** on the front of the control box for motorized STM7-CBA is turned ON.
- 3 To cancel the lower software limit, keep pressing the Z LIMIT button **c** again until the buzzer beeps.

⊙ The status whether the lower software limit is set or cancelled can be confirmed with the Z LIMIT **e** of the digital indicator STM7-DI.

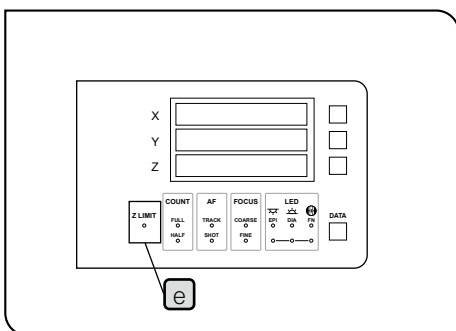
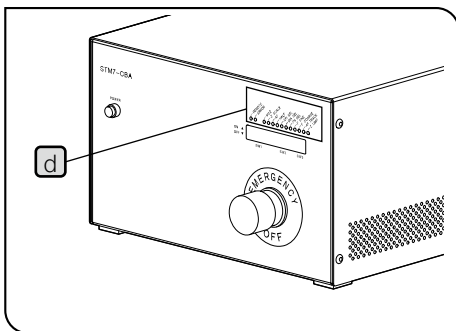
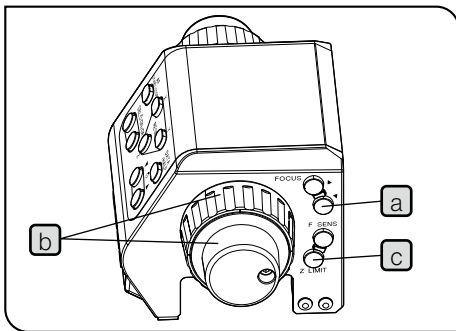

	Lower software limit: set			Lower software limit: cancelled				
Z LIMIT of STM7-DI (Always displayed)	Z LIMIT ●	COUNT FULL ○ HALF ○	AF TRACK ○ SHOT ○	FOCUS COARSE ○ FINE ○	Z LIMIT ○	COUNT FULL ○ HALF ○	AF TRACK ○ SHOT ○	FOCUS COARSE ○ FINE ○

⊙ If the origin search is set to ON, the lower software limit setting is kept even though the main switch of the control box for motorized is set to "●" (OFF) when the main switch is ON next time. For the origin search setting, refer to page 51.

3-5 Observation tube

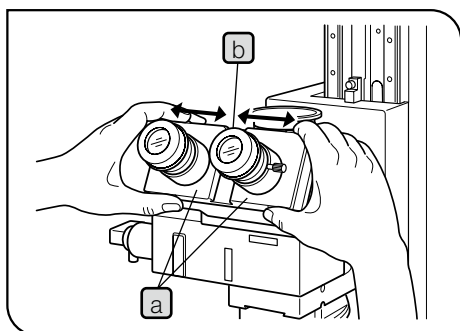

1 Interpupillary distance adjustment (MM6-ETR)

Look into the eyepiece sleeves and slide the interpupillary distance adjustment seats **a** so that the visual fields of the two eyes coincide.

- ⊙ By memorizing the user's own interpupillary distance shown by the interpupillary distance scale **b** on the center, optimum interpupillary distance can be set by referring to this scale from the next time.

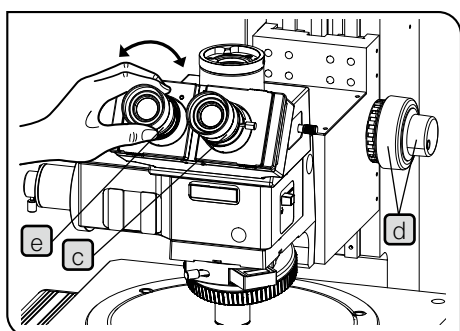

2 Diopter adjustment

- 1 Look into the right eyepiece sleeve with the right eye and adjust the diopter adjustment ring **c** on the upper part of the eyepiece so that the cross hairs are sharp.
- 2 Rotate the fine/coarse focusing knob **d** of the focusing unit or the fine/coarse focusing knob **f** of the focus controller STM7-MCZ to bring the specimen on the stage into focus.

For details of the focus controller STM7-MCZ, see "3-4 Focus controller (Motorized frame only)" (page 28).

- 3 Look into the left eyepiece sleeve with the left eye and bring the specimen in focus by rotating only the diopter adjustment ring **e** on the upper part of the eyepiece. (In case of binocular system)

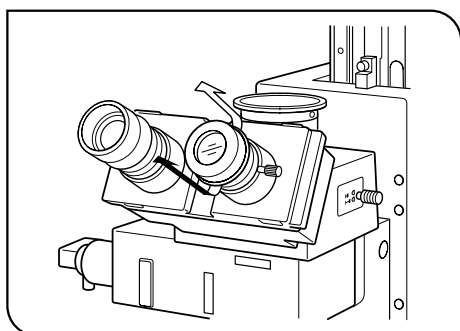
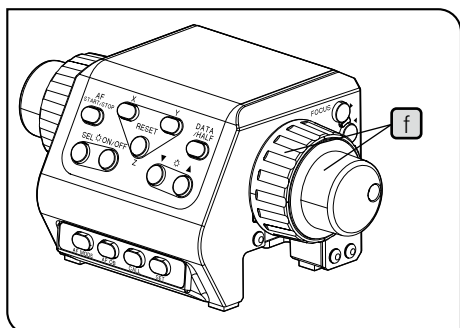

3 Using the eye shades

- ⊙ Try not to let the room's illumination directly enter the eyepieces for easier viewing.

Observation Using Eyeglasses

Fold the eye shades to prevent damage due to contact between the eyeglasses and eyepiece lenses.

Observation Without Using Eyeglasses

Extend the eye shades in the direction of the arrows to facilitate observation by preventing penetration of incident light through the space between the eyes and eyepiece lenses.

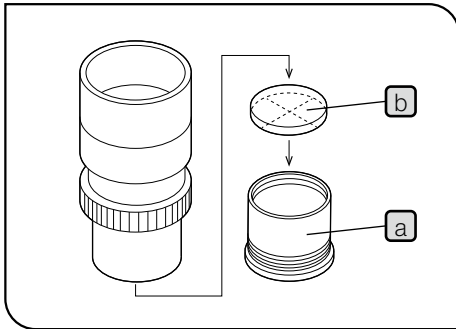

4 Replacing the eyepiece cross

The cross on each eyepiece sleeve can be replaced except with the MM6-OCC10X.

The size other than the cross should be diameter of 24 mm and thickness of 1.5 mm.

To attach a new cross, remove the cross-frame **b** and drop in the cross **a** so that the side with indications faces downwards.

Attach the cross-frame **b** again before observation.

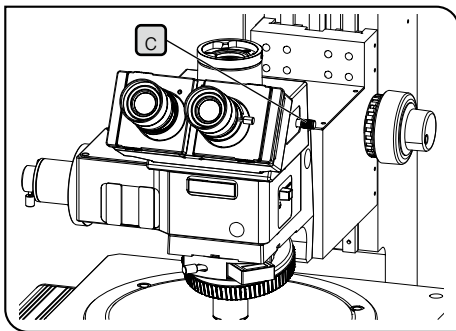

5 Switching the light path (MM6-ETR)

Slide the light path selector knob **c** to select the desired light path.

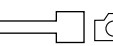
Indication	Lever Position	Light Ratio	Purpose
	Pushed in	100% observation	Observation
	Pulled out	100% TV/photo	TV observation, photomicrography

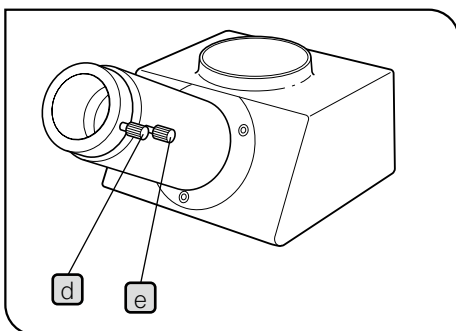

6 Erect image monocular observation tube (MM6-EMO)

The MM6-EMO is designed for monocular observation of erect images.

The upper clamping screw **d** is used to clamp the eyepiece and the lower clamping screw **e** is used to clamp the eyepiece adapter.

3-6 Reflected light illuminator

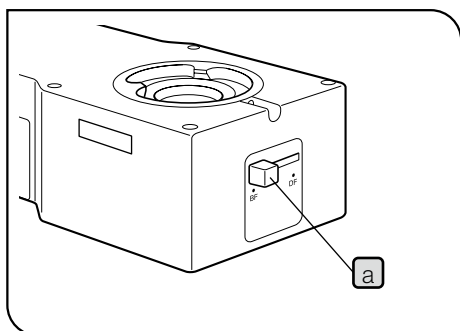

1 Switching the light path of brightfield/darkfield reflected light illuminator (MM6C-RLAS)

Set the brightfield/darkfield switch knob **a** for the desired observation method.

Slide the brightfield/darkfield switch knob correctly into a stopper position.

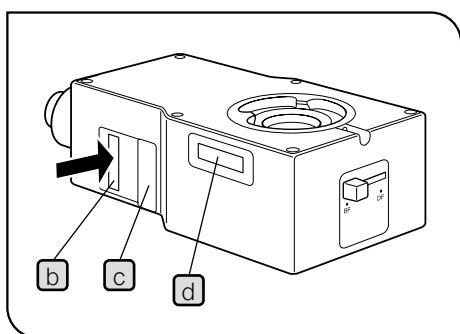

2 Using the filters (MM6C-KMAS,MM6C-RLAS)

Through the filter insertion slot **b**, insert and engage the filter slider set for the desired observation purpose in the light path.

Be sure to insert from the arrow side shown in the figure on the left.

The first click engages the idle position of the slider and the second click engages the filter in the light path.

CAUTION • Since dust or dirt attached to the filter may be visible in the field of view, clean the filter before each use.

• Do not insert the filter sliders listed below into the polarizer **c** and analyzer **d** slots.

Filter used	Purpose
U-25ND25 (Light adjustment filter)	Adjustment of the light source intensity. (Transmittance 25%)
U-25ND6 (Light adjustment filter)	Adjustment of the light source intensity. (Transmittance 6%)

3-7 Stage

1 Moving the specimen

- ◎ The specimen can be moved with the X-, Y-axis knob or freely according to the position of the clutch levers.

CAUTION When observing a light specimen, perform the clutch operation especially carefully to avoid deviation of the specimen position. It is recommended securing the specimen.

Free Movement

If you tilt the X-axis and Y-axis clutch levers **a** **b** either to the right or left direction, the clutches are released and the stage can be moved freely. .

Hold the knob **c** to move the stage.

In case of STM7-CS50, the Y-axis knob is on the left side of the stage.

CAUTION • Do not hold the right side area where a caution label **d** is attached.

- If the frame is not centered, the stage may move spontaneously. In this case, center the frame.

Movement Using X- and Y-axis Knobs

Rotating up the X-axis and Y-axis clutch levers **a** **b** for a half turn slowly will fix the clutches. And the stage can be moved by using the X- and Y-axis knobs **e** **f**.

- ◎ If a clutch cannot be engaged, try engaging the clutch again or turn the feed knob slightly and retry.

CAUTION • Do not operate the clutch levers while the stage is moving. Otherwise, accuracy degradation or damage may result.

- Do not touch any part except the stage knob **c**, X-axis or Y-axis knob **e** **f**.
- After use, return the stage to the center position and lock the clutch to maintain the stage accuracy. And do not place a heavy object on the stage.
- An extremely flat or highly polished specimen may adhere to the stage glass, and forcibly pulling up such a specimen may cause the stage glass to detach. To prevent this, remove the adhered specimen by sliding it laterally.
- If the stage is moved finely or reciprocated repeatedly by operating the X-axis and Y-axis knobs **e** **f**, the slippage may be caused on the stage guide and the stage may not move. If the stage does not move, release the clutch and hold the knob **c** to move the stage.

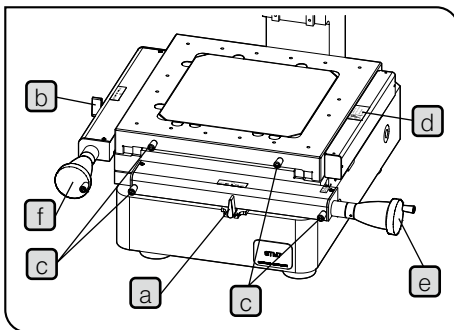

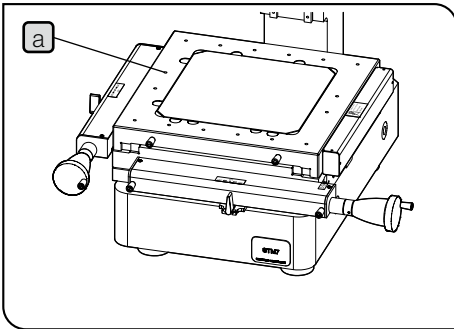

2 Clamping the option and jig tool

The rotatable stage and jig tool can be attached using the tap **a**.
(M4 threading, depth max. 7 mm)

- ⊙ Flatness of the mounting surface of the jig attached to the stage should be 40 μm or less.
If the flatness of the mounting surface of the jig is bad, the stage may be damaged.
- ⊙ Be sure to prevent the jig from touching the glass surface.
The glass surface is protruded from the stage surface. If the jig is attached to the stage while touching the glass surface, the glass may be broken or the stage may be distorted and damaged.

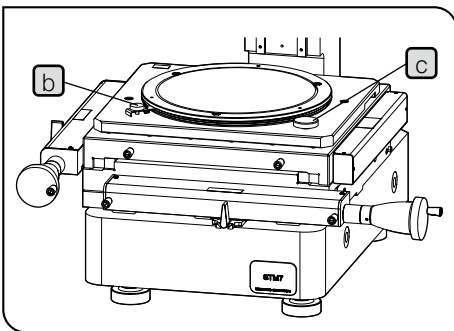

3 Adjusting the parallelism of specimen

STM7-CS50/STM7-RS100/STM7-RS200/STM7-RS300

Rotate the rotation clamp knob **b** in the counterclockwise direction to cancel the fixing of the rotatable stage. Then, rotate the fine focusing knob **c** with fingers to adjust the parallelism of the measurement object.

When the parallelism of measurement objects is adjusted, rotate the rotation clamp knob **b** in the clockwise direction to fix the rotatable stage.

STM7-CS50

Adjust the parallelism of the measurement objects by holding the fine focusing knob **d**.

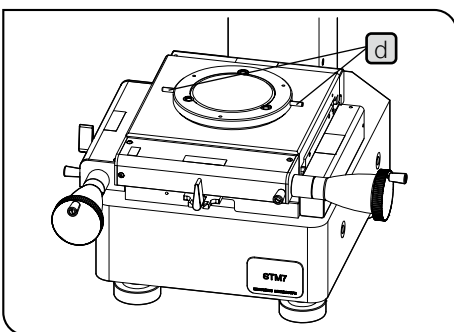

4 Replacing the stage glass

When the stage glass is dimmed, scratched or cracked after long hours of use, the stage glass should be replaced.

CAUTION • Ask Evident to replace the stage glass.

- The stage glass has been adjusted to ensure flatness. Therefore, height adjustment is required after replacement of the stage glass.

3-8 Focus navigator unit

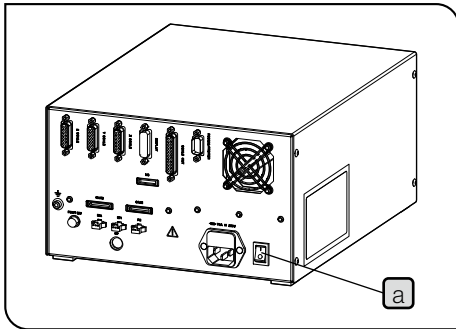

1 Method of focus

- 1 Set the main switch **a** on the rear of the control box STM7-CB/STM7-CBA to **I** (ON). (Only when using the control box.)
- 2 Set the main switches of the modules you are using to **I** (ON). (For details, refer to the instruction manual provided with each module.)
- 3 Adjusts interpupillary distance of the observation tube and the diopter of eyepiece. (see page 33)

⊙ The interpupillary and the diopter influence focusing repeatability. Adjust surely.

- 4 Adjust the brightness of the reticle by using the light intensity control function of the hand switch STM7-HS, the focus controller STM7-MCZ or the power supply unit.

For details, refer to "3-3 Hand switch (Manual frame only)" (page 25), "3-4 Focus controller (Motorized frame only)" (page 28) or the instruction manual provided with the power supply unit.

⊙ Make the brightness of the reticle slightly darker to prevent your eyes from getting tired.

- 5 Move the focusing unit to search the focusing position. (See page 24 for manual frame and page 28 for motorized frame.) In the focus position, the top and the bottom of the reticle fits.

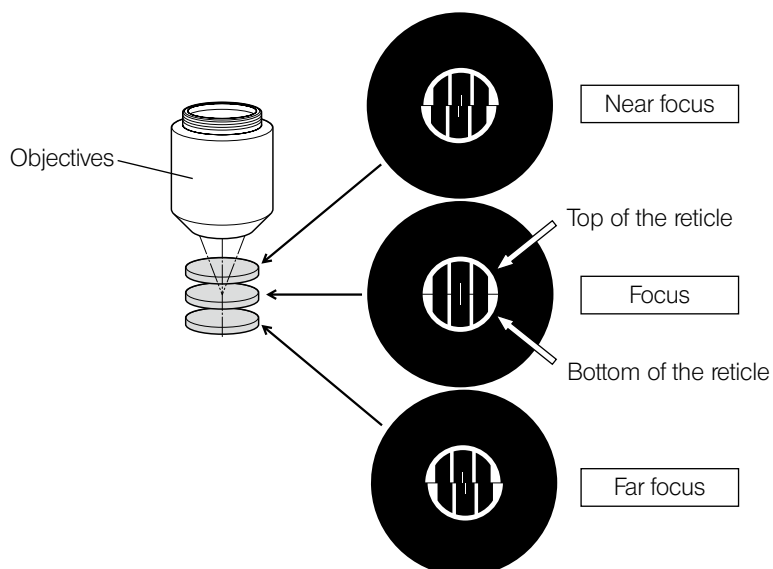

3-9 Autofocus unit (Motorized frame only)

1 Autofocusing modes

The AF unit provides the following two operation modes.

1) ONE SHOT mode

When autofocusing is activated at the position where you want to detect focusing, focusing is detected only once at that position.

2) TRACK mode

The focusing unit is tracked automatically so that the measurement target is kept in focus even when it is moved.

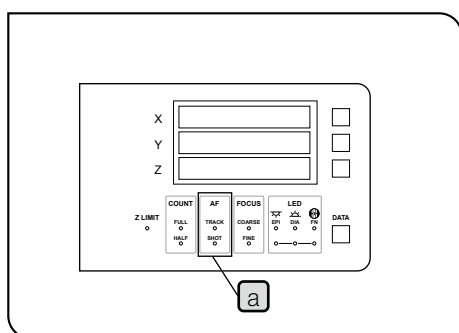

☉ The AF operation mode can be confirmed with the AF **a** of the digital indicator STM7-DI.

	ONE SHOT mode			TRACK mode				
AF of STM7-DI (Always displayed)	Z LIMIT ○	COUNT FULL ○ HALF ○	AF TRACK ○ SHOT ●	FOCUS COARSE ○ FINE ○	Z LIMIT ○	COUNT FULL ○ HALF ○	AF TRACK ● SHOT ○	FOCUS COARSE ○ FINE ○

2 Focusing position adjustment

☉ Adjust the focusing position every time after switching the objective.

1 Set the main switch **b** on the rear of the control box for motorized STM7-CBA to **↑** (ON).

The [AF] indicator **c** on the front of the control box for motorized is turned ON.

2 Set the main switches of the modules you are using to **↑** (ON).
(For details, refer to the instruction manual provided with each module.)

3 Adjust the diopter of the eyepiece. (see page 33)

4 Approximately focus on an apparently flat specimen (such as a mirror or the glass surface of stage). (see page 28)

5 Press the AF MODE button **d** on the focus controller STM7-MCZ. (LASER LED **e** on the front of the autofocus unit is turned ON and SHOT of the digital indicator STM7-DI blinks to be in the AF standby status.)

6 Press the AF OB button **f** on the focus controller.
Every time the AF OB button is pressed, the lighting status of the objective magnification display LED **g** on the front of the autofocus unit is changed.

Keep pressing the AF OB button until the objective magnification display LED which adjusts the focusing position is turned ON.

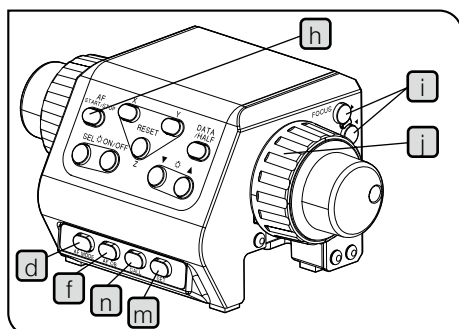
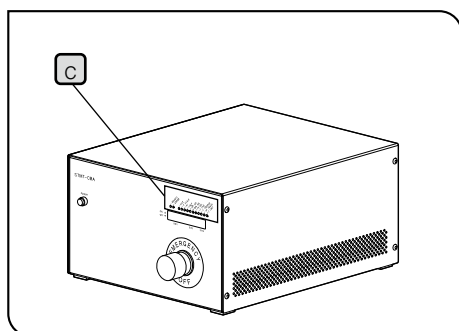
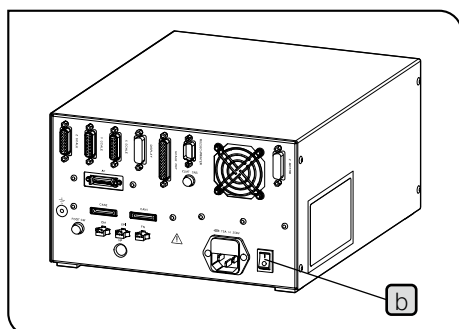

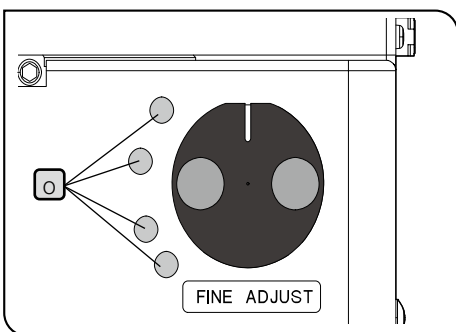
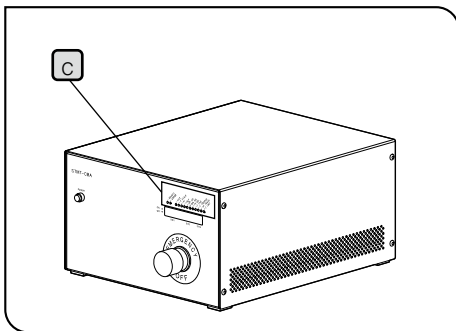
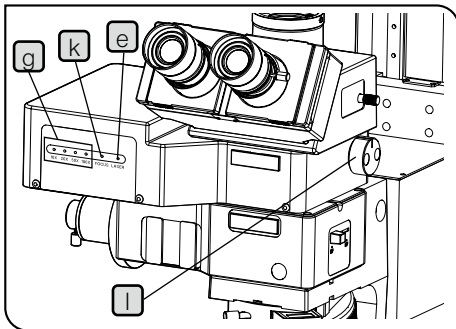
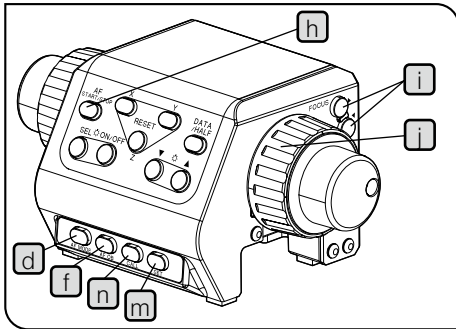

7 Press the AF MODE button **d** on the focus controller. (The [AF TRACK] indicator **c** on the front of the control box for motorized is turned ON and TRACK of the digital indicator blinks to be in the TRACK mode.)

8 Press the AF START/STOP button **h** on the focus controller. (TRACK of the digital indicator is turned ON to execute AF in the TRACK mode.)

When the focusing position is detected, the AF tracks the concave/convex of the specimen.
(FOCUS LED **k** on the front of the autofocus unit is turned ON)

When the focusing position cannot be detected, three short beeps indicating an error are generated and FOCUS LED **k** on the front of the autofocus unit blinks. Operate the FOCUS button **i** of the focus controller or the coarse focusing knob **i** to move the focusing unit closer to the focusing position. Then, the focusing position will be detected automatically and it tracks at the focusing position.

CAUTION Be careful not to allow the objective to collide with measurement objects.

9 Rotate the FINE ADJUST knob **l** of the autofocus unit to adjust so that the specimen becomes clearly visible.

10 Attach the aberration correction seal provided with the autofocus unit at the adjusted knob position **o**.

- With 10X objective: yellow
- With 20X objective: green
- With 50X objective: blue
- With 100X objective: white

11 Now the focusing position adjustment is possible.

Perform the following operation to stop autofocusing.

- 1) Press the AF START/STOP button **h** on the focus controller. (TRACK of the digital indicator blinks to stop the AF operations in TRACK mode. And the system is in the standby mode again.)
- 2) Press the AF MODE button **d** on the focus controller. (The [AF TRACK] indicator **c** on the front of the control box for motorized, TRACK of the digital indicator, Laser LED **e** and FOCUS LED **k** on the front of the autofocus unit are all turned OFF)

Memorizing objective magnification

Keep pressing the SET button **m** until the buzzer beeps to memorize the objective magnification in the microscope.

- ⊙ When using the coded revolving nosepiece, up to five objective magnifications can be memorized.
- ⊙ The current light intensity values of each illumination are also memorized.

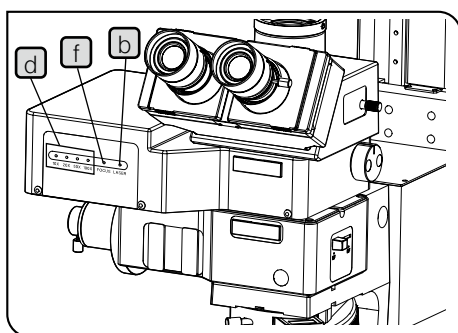
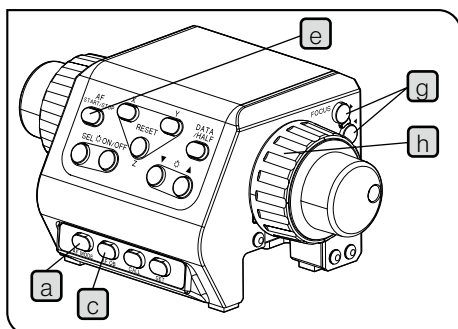

3 Measurement by manual readout in ONE SHOT mode

⊙ To perform this operation, the setting to transmit the counter data automatically must be OFF when setting the DIP switch. For details, refer to "5-1 Preparation (setting DIP switch and rotary switch)" (page 49).

- 1 Press the AF MODE button **a** on the focus controller STM7-MCZ. (LASER LED **b** on the front of the autofocus unit is turned ON and SHOT of the digital indicator STM7-DI blinks to be in the AF standby status.)
- 2 Turn ON the objective magnification display LED **d** on the front of the autofocus unit you want to use by using the AF OB button **c** of the focus controller. Then, engage the objective displayed into the light path.
- 3 Approximately focus on the specimen (page 28) and bring the point at which you want to detect focusing to the center of crosslines of the eyepiece (page 36).
- 4 Press the AF START/STOP button **e** on the focus controller. (SHOT of the digital indicator is turned ON.)

When the focusing position is detected, one short beep indicating the completion is generated.

(FOCUS LED **f** on the front of the autofocus unit is turned ON and SHOT of the digital indicator blinks.)

When the focusing position cannot be detected, three short beeps indicating an error are generated and FOCUS LED **f** on the front of the autofocus unit blinks and SHOT of the digital indicator is turned ON. When moving the focusing unit closer to the focusing position by the FOCUS button **g** of the focus controller or the coarse focusing knob **h**, AF is executed again automatically.

- 5 The Z-axis height and level difference at the focusing position can be read out from the Z-axis counter indication on the digital indicator.
- 6 Finish AF.
When the focus position is detected, press the AF MODE button **a** of the focus controller twice.
When the focus position is not detected, press the AF START/STOP button **e** of the focus controller once and press the AF MODE button **a** twice. (LASER LED **b** and FOCUS LED **f** on the front of the autofocus unit and SHOT of the digital indicator are turned OFF)

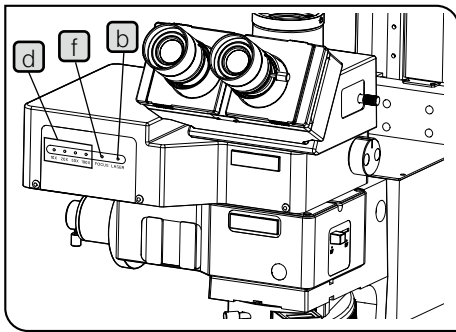
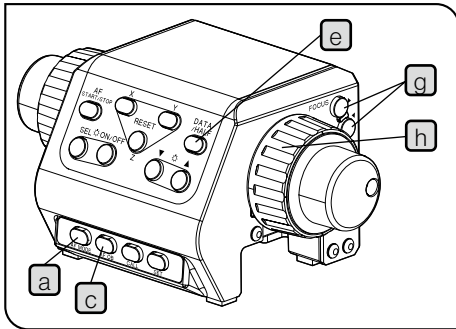

4 Measurement by auto readout in ONE SHOT mode

⊙ To perform this operation, the setting to transmit the counter data automatically must be ON when setting the DIP switch. For details, refer to "5-1 Preparation (setting DIP switch and rotary switch)" (page 49).

- 1 Press the AF MODE button **a** on the focus controller STM7-MCZ. (LASER LED **b** on the front of the autofocus unit is turned ON and SHOT of the digital indicator STM7-DI blinks to be in the AF standby status.)
- 2 Turn ON the objective magnification display LED **d** on the front of the autofocus unit you want to use by using the AF OB button **c** of the focus controller. Then, engage the objective displayed into the light path.
- 3 Approximately focus on the specimen (page 28) and bring the point at which you want to detect focusing to the center of crosslines of the eyepiece (page 36).
- 4 Press the DATA/HALF button **e** on the focus controller. (SHOT of the digital indicator is turned ON.)

When the focusing position is detected, a short beep indicating completion is generated and the coordinates are output to the external computing device. (FOCUS LED **f** on the front of the autofocus unit is turned ON and SHOT of the digital indicator blinks.)

When the focusing position cannot be detected, three short beeps indicating an error are generated. FOCUS LED **f** on the front of the autofocus unit blinks and SHOT of the digital indicator is turned ON. When moving the focusing unit closer to the focusing position by rotating the FOCUS button **g** of the focus controller or the coarse focusing knob **h**, AF is executed again automatically and the coordinates are outputted.

⊙ When using a foot switch, AF and auto readout can be executed by pressing the foot switch in place of the DATA/HALF button **e**.

⊙ AF and auto readout can be executed by pressing the DATA/HALF button of the digital indicator.

- 5 To exit AF, press the AF MODE button **a** on the focus controller twice. (LASER LED **b** and FOCUS LED **f** on the front of the autofocus unit and SHOT of the digital indicator are turned OFF.)

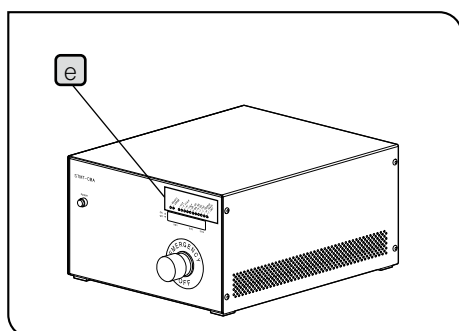
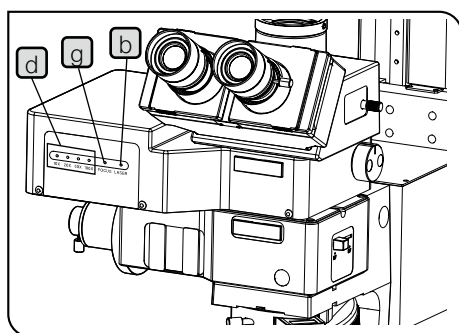
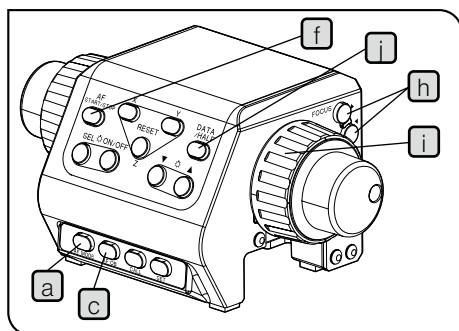

5 Measurement in TRACK mode

- 1 Approximately focus on the specimen (page 28)
- 2 Press the AF MODE button **a** on the focus controller STM7-MCZ. (LASER LED **b** on the front of the autofocus unit is turned ON and SHOT of the digital indicator STM7-DI blinks to be in the AF standby status.)
- 3 Turn ON the objective magnification display LED **d** on the front of the autofocus unit you want to use by using the AF OB button **c** of the focus controller. Then, engage the objective displayed into the light path.
- 4 Press the AF MODE button **a** on the focus controller. (The [AF TRACK] indicator **e** on the front of the control box for motorized is turned ON and TRACK of the digital indicator blinks to be in the TRACK mode.)
- 5 Bring the point at which you want to detect focusing to the center of crosslines of the eyepiece (page 36).
- 6 Press the AF START/STOP button **f** on the focus controller. (TRACK of the digital indicator is turned ON to execute AF in the TRACK mode.)

When the focusing position is detected, short beeps indicating the beginning of tracking are generated and tracking at the focusing position starts. (FOCUS LED **g** on the front of the autofocus unit is turned ON.)

When the focusing position cannot be detected, three short beeps indicating an error are generated and FOCUS LED **g** on the front of the autofocus unit blinks.

When moving the focusing unit closer to the focusing position by rotating the FOCUS button **h** of the focus controller or the coarse focusing knob **i**, the focusing position is detected automatically and it tracks at the focusing position after the one short beep indicating the start of tracking is generated.

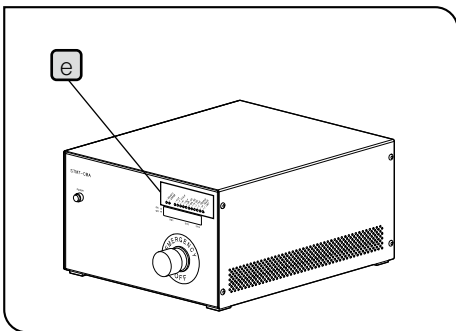
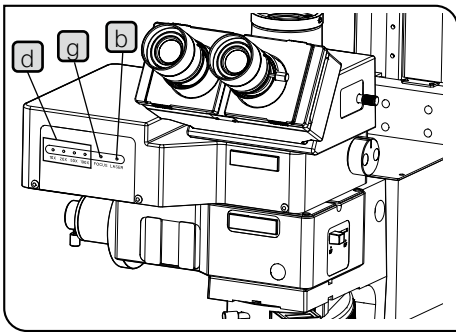
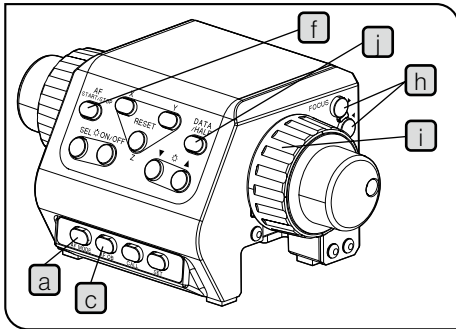

- 7** When the unit tracks at the focusing position of a specimen with steep or big level differences, the unit sometimes misses the focusing position and becomes no longer capable of tracking. (FOCUS LED **d** on the front of the autofocus unit blinks.) Should this be the case, press the AF START/STOP button **f** on the focusing controller twice to resume the search operation.

When the focusing position is detected, one short beep indicating the beginning of tracking is generated and tracking at the focusing position starts.

(FOCUS LED **d** on the front of the autofocus unit is turned ON.)

When the focusing position cannot be detected, three short beeps indicating an error are generated and FOCUS LED **d** on the front of the autofocus unit blinks.

When moving the focusing unit closer to the focusing position by rotating the FOCUS button **h** of the focus controller or the coarse focusing knob **i**, the focusing position is detected automatically and it tracks at the focusing position after the one short beep indicating the start of tracking is generated.

- 8** When you press the DATA/HALF button **j** on the focusing controller during tracking at the focusing position, the coordinates at that time are output to the external computing device.
- 9** To stop tracking at the focusing position, press the AF START/STOP button **f** on the focusing controller. (TRACK of the digital indicator blinks.)
- 10** To exit AF, press the AF MODE button **a** on the focus controller. (LASER LED **b** and FOCUS LED **d** on the front of the autofocus unit, the [AF TRACK] indicator **e** on the front of the control box for motorized and TRACK of the digital indicator are turned OFF.)

⊙ Autofocusing selection cannot be changed during operation in TRACK mode.

Press the AF START/STOP button **f** to stop operation in TRACK mode before changing the autofocusing selection.

Trackable level difference (Reference value using mirror sample)	With 10X objective: ±500 μm
	With 20X objective: ±150 μm
	With 50X objective: ±20 μm
	With 100X objective: ±5 μm

3-10 Foot switch

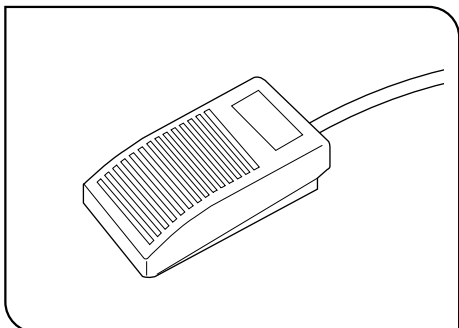

- © When the foot switch is connected to FOOT SW connector of the control box STM7-CB/STM7-CBA, the counter data can be transmitted to the controller or the printer, etc. by pressing the foot switch.

3-11 Basic software

- © With the basic software STM7-BSW, various measurements can be performed and measurement results can be saved. For details, refer to the instruction manuals provided with Basic software / MIAEFI option software.

3-12 External processing device

- © The external processing device can be connected using the DSUB25Pin female cable. Contact Evident for details.

3-13 Printer

- © The printer can be connected using the RS-232C interface (DSUB9Pin male) of STM7. Contact Evident for details.

4 OBSERVATIONS (using MM6C-KMAS or MM6C-RLAS)

4-1 Reflected light brightfield observation

⊙ No description is given on the brightfield reflected light arm MM6C-VL because only the brightfield observation is in question in this section.

4-2 Reflected light DIC observation

CAUTION • Replace the polarizer after about 2000 hours of continuous use because its performance degrades after it has been subjected to light for a long period.

• When transmitted light observation is to be performed, first remove the polarizer from the light path. Otherwise, flare may occur in the field of view.

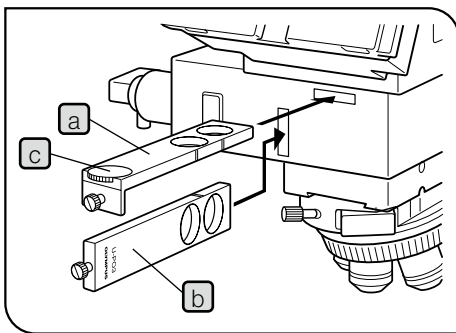

1 Mounting the analyzer and polarizer

CAUTION At this stage, do not engage the DIC slider in the light path yet.

1 Approximately focus on the specimen using the 10X or 20X objective.

2 Remove the dummy slider from the analyzer insertion slot.

⊙ When using the autofocus unit STM7-AF, remove the dummy slider from the analyzer insertion slot **(d)** of the autofocus unit.

3 Hold the analyzer U-AN360-3 **(a)** with the name plate facing up, then mount the analyzer into the analyzer insertion slot.

CAUTION When using the U-AN, take care not to push it in past the click position. Otherwise, the U-AN may get stuck in the back and be incapable of being removed.

⊙ When using the autofocus unit STM7-AF, insert the analyzer to the analyzer insertion slot **(d)** of the autofocus unit.

4 Mount the polarizer U-PO3 **(b)** by inserting it into the light path of the reflected light arm MM6C-KMAS or MM6C-RLAS so that the surface with indications faces right.

5 Place a specimen with high reflectance, such as a mirror, on the stage and approximately focus on it.

6 While looking through the eyepieces, rotate the analyzer rotation dial **(c)** so that the light is darkest.

⊙ The cross-Nicol position is obtained when the index on the dial **(c)** comes on the outside position. Rotate the dial around that position so that the light looks darkest.

Using the Connecting Plate

When the analyzer U-AN360-3 **(f)** and polarizer U-PO3 **(g)** are combined using the connection plate **(e)** provided with the polarizer (when the MM6C-KMAS is in use, or provided with the MM6C-RLAS when this is in use) and clamped with the clamping knob as shown in the figure on the left, they can be engaged in or disengaged from the light path together.

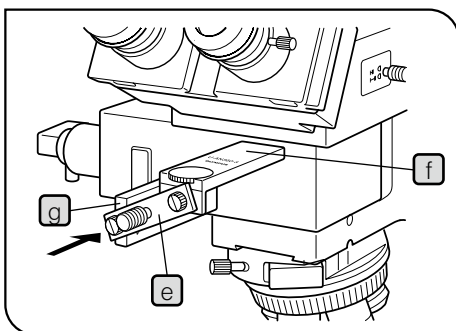
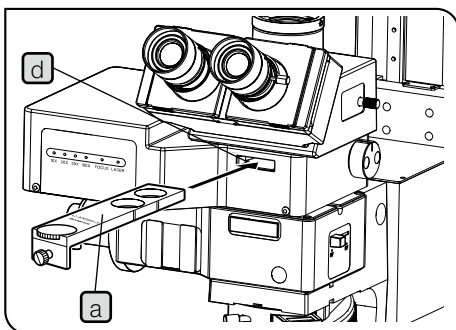

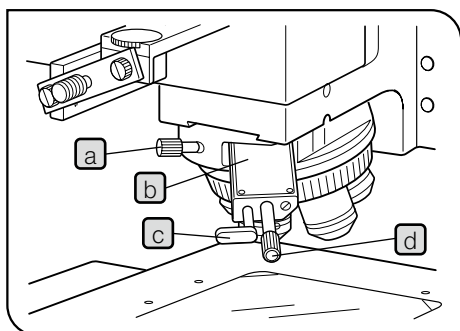

2 Setting the DIC slider

- 1 Loosen the clamping knob **a** on the front of the DIC revolving nosepiece, remove the dummy, insert the DIC slider **b** so that the surface with indications faces upward, and tighten the clamping knob.
- 2 If MPLFLN/UMPlanFI series objectives are in use, push in the switch lever **c**. If LMPLFLN/LMPLanFI series objectives are in use, pull out the switch lever.

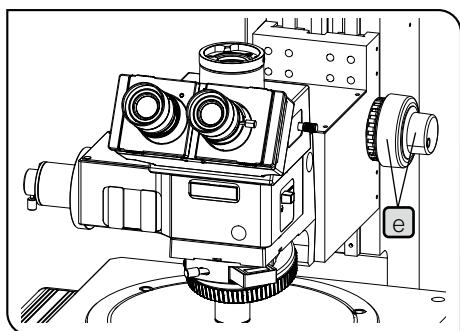

3 Observation procedure

Place the specimen on the stage, and rotate the fine/coarse focusing knob **e** of the focusing unit or the fine/coarse focusing knob **f** of the focus controller STM7-MCZ to bring the specimen on the stage into focus.

For details of the focus controller STM7-MCZ, see "3-4 Focus controller (Motorized frame only)" (page 28).

U-DICR

- 1 Rotate the prism movement knob **d** of the DIC slider **b** within the range from -100 to 600 nm to adjust the background color contrast.
- 2 Rotating the prism movement knob **d** on the DIC slider **b** varies the background interference color continuously from gray sensitive color to magenta sensitive color (-100 to 600 nm). Set the interference color providing highest contrast for the specimen in use.

⊙ When the background color is set to the gray color, observation with excellent contrast and three-dimensionality can be performed due to the highest-speed gray sensitive color.

⊙ When the background color is set to the magenta sensitive color, even very small change in phase can be observed as change in color.

⊙ When using the autofocus unit STM7-AF, the focusing may not be available within the adjustment range (where the interference color is near orange.) of certain DIC prisms.

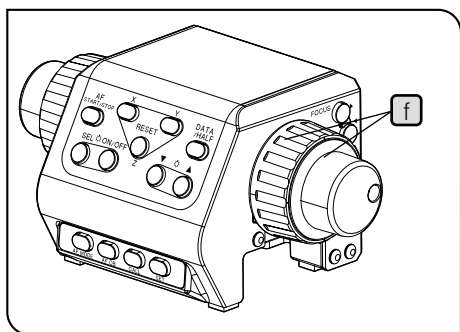

4 Switching to brightfield observation

- 1 Loosen the clamping knob **a** on the front of the DIC revolving nose, pull out gently the DIC slider **b** until it clicks, then tighten the clamping knob **a**.
- 2 Slide out the analyzer U-AN360-3 and the polarizer to disengage them from the light path.

4-3 Reflected Light Simplified Polarized Light Observation

- ⊙ For the preparation of reflected light simplified polarized light observation, perform the operation in "1 Mounting the analyzer and polarizer" in section "4-2 Reflected light DIC observation" on page 46.

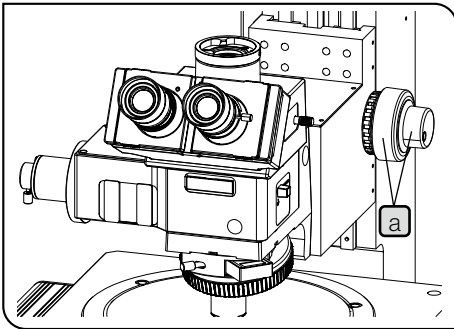

1 Observation procedure

- ⊙ Place the specimen on the stage, and rotate the fine/coarse focusing knob **a** of the focusing unit or the fine/coarse focusing knob **b** of the focus controller STM7-MCZ to bring the specimen on the stage into focus.

Now the microscope is ready for simplified polarized light observation.

- ⊙ For details of the focus controller STM7-MCZ, see "3-4 Focus controller (Motorized frame only)" (page 28).

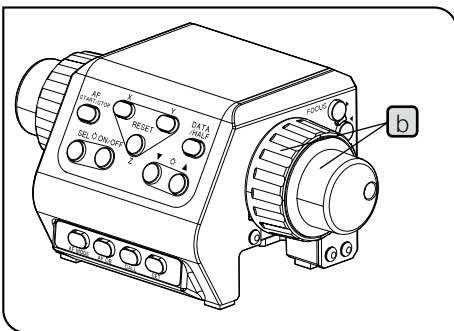

5 MEASUREMENT

5-1 Preparation (setting DIP switch and rotary switch)

◎ Following settings are available by the DIP switch of the control box STM7-CB/STM7-CBA.

- 1) Unit ($\mu\text{m}/\text{mm}/\text{inch}/\text{mil}$)
- 2) Minimum digit
- 3) Buzzer
- 4) Restoration of light intensity value at startup
- 5) Enable/disable of LED control for focus navigator unit
- 6) Whether or not to transmit the counter data
- 7) Enable/disable of interlock between coded revolving nosepiece and illumination
- 8) Output of counter data when using the autofocus unit
- 9) Origin search at startup
- 10) Microscope information display time
- 11) Axis to transmit the counter data

◎ Be sure to set the DIP switch when the main switch of the control box is "●" (OFF).

When the main switch is set to "↑" (ON), the setting of the DIP switch is loaded to the microscope.

CAUTION • Be careful not to touch the internal circuit boards when setting the DIP switches. If a circuit board is contacted, it may be destroyed by the static electricity.

• Since a human body is charged with a small amount of static electricity, it should be discharged from your body before proceeding to setting. The static electricity in your body can be discharged by simply touching any metallic object.

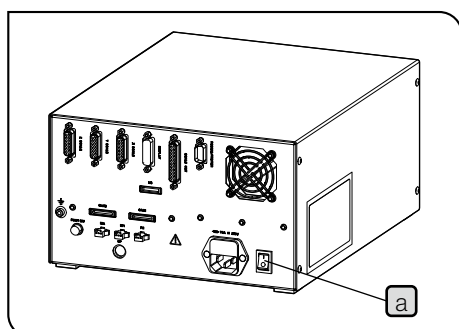

- 1** Set the main switch **a** on the rear of the control box STM7-CB/STM7-CBA to "●" (OFF).

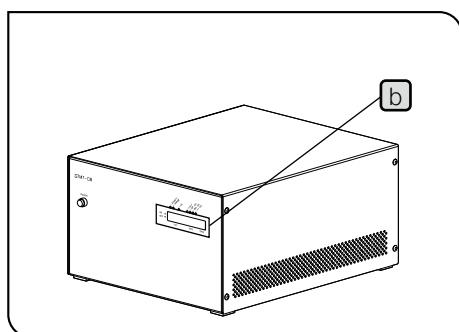

- 2** Take off the seal **b** on the front of the control box.

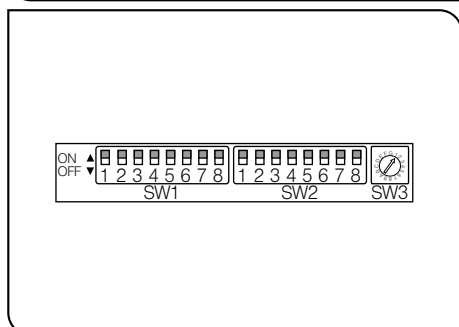

- 3** Set the DIP switches by using a flat-blade screwdriver.

Unit (μm /mm/inch/mil)

Set the units of the counter data.

Setting items	(1)		(2)		Example
	DIP switch	DIP switch setting	DIP switch	DIP switch setting	
mm	SW1-1	OFF	SW1-2	OFF	101.6000
μm				ON	101600.0
inch	SW1-1	ON	SW1-2	OFF	4.00000
mil				ON	4000.00

Minimum digit display

Set whether or not to display the minimum digit.

Setting items	DIP switch	DIP switch setting	Example
The minimum digit is displayed.	SW1-3	OFF	101.6000
The minimum digit is not displayed.		ON	101.600

Buzzer

Set whether or not to beep the buzzer to notify the error or the microscope status.

Setting items	DIP switch	DIP switch setting
The buzzer is beeped.	SW1-4	OFF
The buzzer is not beeped.		ON

Restoration of light intensity value and objective magnification at startup

Set whether or not to load the last light intensity value memorized to the microscope with the hand switch STM7-HS or the focus controller STM7-MCZ when you start the microscope.

Setting items	DIP switch	DIP switch setting
The light intensity value is not loaded. (The initial value of the factory default is loaded.)	SW1-5	OFF
The light intensity value is loaded		ON

Enable/disable of focus navigator unit

When selecting the illumination you want to control by using the hand switch STM7-HS or the focus controller STM7-MCZ, set whether or not to allow the focus navigator unit STM7-FN selectable.

Setting items	DIP switch	DIP switch setting
The control of the focus navigator unit LED is disabled.	SW1-6	OFF
The control of the focus navigator unit LED is enabled.		ON

Whether or not to transmit the counter data

Set whether or not to transmit the counter data to other external processing devices when detecting the connection between the digital indicator STM7-DI and the microscope.

Setting items	DIP switch	DIP switch setting
When the digital indicator is connected, the counter data is not transmitted to other external processing devices. When the digital indicator is not connected, the counter data is transmitted to other external processing devices.	SW1-7	OFF
The counter data is transmitted to other external processing devices.*1		ON

*1 Regardless of the connection with the digital indicator STM7-DI.

Enable/disable of interlock between coded revolving nosepiece and illumination

Set whether or not to interlock the illumination ON/OFF status and the light intensity values with the switching of the coded revolving nosepiece.

Setting items	DIP switch	DIP switch setting
Not interlocked	SW1-8	OFF
Interlocked		ON

Output of counter data when LASER LED of the autofocus unit is turned ON



When using the autofocus unit STM7-AF and the LASER LED is turned ON, set functions when the DATA/HALF button of the focus controller STM7-MCZ is pressed.

Setting items	DIP switch	DIP switch setting
The counter data is outputted.	SW2-1	OFF
After AF is performed successfully, the counter data is outputted.*2		ON



*2 If the autofocus is not performed successfully, the counter data is not outputted.

Origin search at startup



Set whether or not to search the origin when you start the microscope.

Setting items	DIP switch	DIP switch setting
Main switch  (ON): The origin is not searched.*3	SW2-2	OFF
Main switch  (ON): The origin is searched.*4		ON

*3 Even though the lower software limit is set during operation, the setting value of the lower software limit is not saved if the main switch is set to "○" (OFF).

*4 When the lower software limit is set, the setting value is saved and even though the main switch is set to "○" (OFF), the setting value is kept. While the lower software limit is set, if the main switch is set to "○" (OFF) and set to  (ON) again, the lower software limit setting is ON automatically after the origin is searched. While the lower software limit setting is cancelled, if the main switch is set to "○" (OFF), the lower software limit will not be set when the main switch is set to  (ON) again.

◎ The origin search refers to the operation of moving the Z-axis to the upper limit within the Z-axis movable area.

◎ When the origin search is set, the Z-axis moves up to the upper limit within the Z-axis movable area immediately after the main switch is set to  (ON). Make sure that the cables are not caught in anything before setting the main switch to  (ON).

◎ When the origin search execution is set, the origin search is also executed after termination of the user Setup mode.

◎ When RS-232C communication equipment is connected, please start RS-232C communication equipment after STM7 ends the origin search.

Time to display the information of the microscope

When operating each button of the hand switch STM7-HS or the focus controller STM7-MCZ, set the display time of the current microscope setting information on the digital indicator STM7-DI.

Setting items	(1)		(2)	
	DIP switch	DIP switch setting	DIP switch	DIP switch setting
The microscope setting information is displayed for two seconds.	SW2-4	OFF	SW2-5	OFF
The microscope setting information is displayed for three seconds.		ON		OFF
The microscope setting information is displayed for four seconds.		OFF		ON
The microscope setting information is displayed for one second.		ON		ON

⊙ The microscope setting information indicates followings.

Illumination to be controlled, ON/OFF of illumination, light intensity value and counter data in 1/2 value

Axis to transmit the counter data

Set the axis to transmit the counter data to the controller or the printer.

Setting items	Rotary switch	Rotary Switch setting
NA	SW3	0
The counter data of X-, Y- and Z-axis is transmitted.		1
The counter data of X- and Y- axis is transmitted.		2
The counter data of Z-axis is transmitted.		3
NA		4 to 9 and A to F

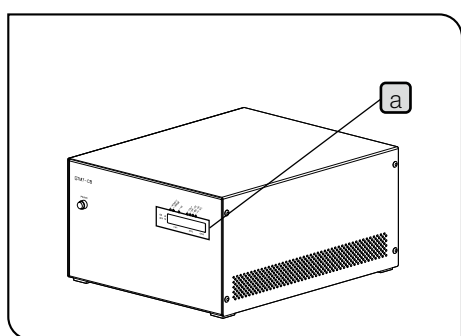

4 Paste the seal **a** on the front of the control box STM7-CB/STM7-CBA.

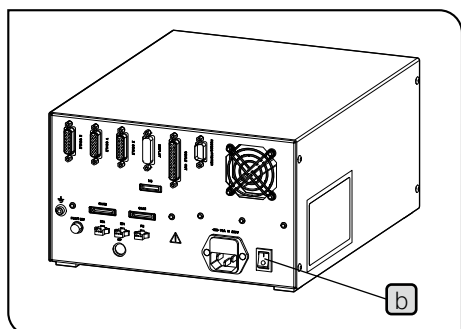

5 Set the main switch **b** on the rear of the control box to **↑** (ON).

⊙ When the main switch of the control box is set to **↑** (ON), the setting of the DIP switch is loaded to the microscope.

How to Use the Illumination Modes

Select the illumination mode ideal for the specimen.

- 1** Transmitted light illumination
The contour of a specimen can be observed as a silhouette.
- 2** Reflected light illumination
Permits observation of the surface of a specimen, especially in the case of a nontransparent specimen.
- 3** Simultaneous use of transmitted and reflected light permits concurrent observation of the contour and surface of the specimen.

Illumination brightness adjustment

Adjust the transmitted/reflected light illuminations to the intensity level that suits the observer.

Focusing

Make a precise focus adjustment on the microscope.

As focusing is a key to accurate measurement and a cause for all errors. Perform focusing properly in the following procedures.

- 1** Make interpupillary distance adjustment and diopter adjustment (page 33).
- 2** Bring the specimen in focus by moving the reflected light arm up and down with the coarse focusing knob on the focusing unit of the microscope or the FOCUS buttons on the focus controller STM7-MCZ. Adjust focusing more precisely using the fine focusing knob on the focusing unit of the microscope or using the fine/coarse focusing knob on the focus controller.
- 3** To ensure the focusing which has been adjusted visually in the above, check for the presence of parallax. While looking through the eyepiece sleeves, move the eyes forward/backward and toward the left and right. Assuming that the cross hairs are stationary, if the image moves in the same direction as the eye movement, bring the objective closer to the specimen. If the image moves in the direction opposite to the eye movement, raise the objective away from the specimen.

© When using the autofocus unit STM7-AF, see "3-9 Autofocus unit (Motorized frame only)" (page 39).

5-2 Measurement of right-angle coordinates

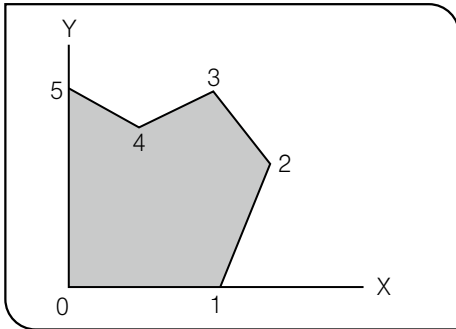

◎ The operability can be improved by using the rotatable stage STM7-RS100/STM7-RS200/STM7-RS300.

- 1 Place the specimen on the center of the stage glass.
- 2 Determine the origin, X-axis and Y-axis of the specimen, and align the direction of stage travel with the axes. For instance, when measuring a thin plate part as shown in figure on the left, set line $\overline{01}$ to the X-axis and line $\overline{05}$ to the Y-axis.

- 3 Move the stage so that the specimen is positioned directly below the objective, then bring the specimen in focus as outlined in **Focusing** on previous page.

Align line 01 with the horizontal cross hair line by alternating specimen rotation (or rotary stage operation) and specimen feeding, then align line 05 with the vertical cross hair line by feeding the specimen. If the specimen tends to be moved by the movement of the stage, fix the specimen with oil clay, etc. At this position, origin 0 of the specimen should be aligned with the intersection of the eyepiece cross hairs, and the counter coordinate readings should be X_0 and Y_0 . Now press the X-RESET and Y-RESET buttons.

- 4 Next, align the intersection of the cross hairs with points 1, 2 and 3 by moving the stage, and read values $X_1, Y_1, X_2, Y_2, \dots$. The difference between these readings and values X_0 and Y_0 indicates the right-angle coordinates of the specimen contour in relation to origin 0.

5-3 Measurement of height (motorized frame only)

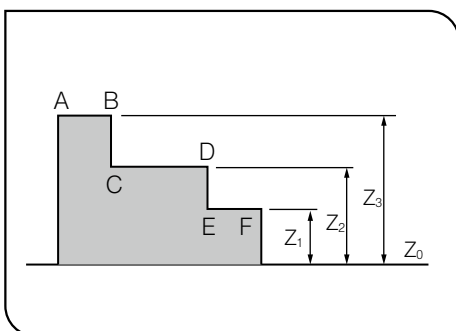

- 1 Place the specimen on the table glass. If right-angle coordinates are to be measured in addition to height, place the specimen as outlined in section 5-2 above.

- 2 Use a **20X or higher-power** objective.

- 3 Bring point Z_0 (on the stage glass surface) into focus. Then press the Z-RESET button.

CAUTION When focusing on the glass surface, be careful not to let the objective hit the specimen or the stage glass.

- 4 Raise the reflected light illumination arm by using the fine/coarse focusing knob of the focusing unit of the frame or the FOCUS button of the focus controller STM7-MCZ. Bring plane E-F into focus and read the counter indication. This reading becomes the value of Z_1 .

- 5 Bring planes C-D then A-B into focus, and take the readings of Z_2, Z_3, \dots, Z_n . The differences between these values and the value of Z_0 indicate the heights of the respective points.

5-4 Measurement of cylinders, round rods and screws

To measure a cylinder, round rod or screw, place the item to be measured directly on the stage glass or use an optional V-shaped support.

Measuring a Cylinder or Round Rod

- 1** For measurement, align the axis of the measured item with either direction of the table travel (normally, X-axis). Obtain the length from the selected direction, and obtain the diameter from the reading on the other direction.
- 2** When securing the measured item on the table, place the item as near as possible to the table center so that the generatrix is approximately parallel to either table travel direction, then bring the item into focus.
- 3** Align the horizontal eyepiece cross hair with the image of the generatrix by rotating the measured item (or the rotatable stage) and adjusting the Y-axis knob.
- 4** Move the table to the left and right until the image of the generatrix and the horizontal cross hair are perfectly parallel.
- 5** Conduct the same procedure for the other generatrix.
- 6** Adjust the Y-axis knob and read the respective values when the two contour lines align with the horizontal cross hair in the eyepiece. The diameter is determined by the difference between the two readings.
- 7** To measure the length, align the axis of the measured item with the horizontal cross hair in the eyepiece, and adjust the X-axis knob.

Measuring a Screw

The outer diameter and groove diameter of a screw can be measured with the same procedure as above.

6 ASSEMBLY

6-1 Assembly Diagram

The diagram below shows the sequence of assembly of the various modules.

The numbers indicate the order of assembly. The modules shown in the following diagram are merely the basic ones. For the modules which are not shown in the diagram, please consult your Evident representative or the latest brochures.

CAUTION • The assembly and adjustments are performed by the Evident dealer. As other tools than those provided with instrument are necessary, the dealer should prepare them.

- In the following conditions, attach the anti vibration plates STM7-VI (option) to the microscope.
 - When installing the microscope in an area with frequent vibration.
 - When installing the microscope on a table with a thin top board. (Basically, prepare a table with a thick top board.)
- When assembling the microscope, make sure that all parts are free of dust and dirt, and avoid scratching any parts or touching glass surfaces. Also be sure to release the transport lock of the focusing unit and stage by removing the screws before use (see page 58 or 61).

⊙ All assembly operations are possible by using the 3 mm Allen screwdriver () and 4 mm Allen wrench () provided with the frame, control box or stage.

⊙ After the assembly is completed, input the setting values of the microscope. (page 74)

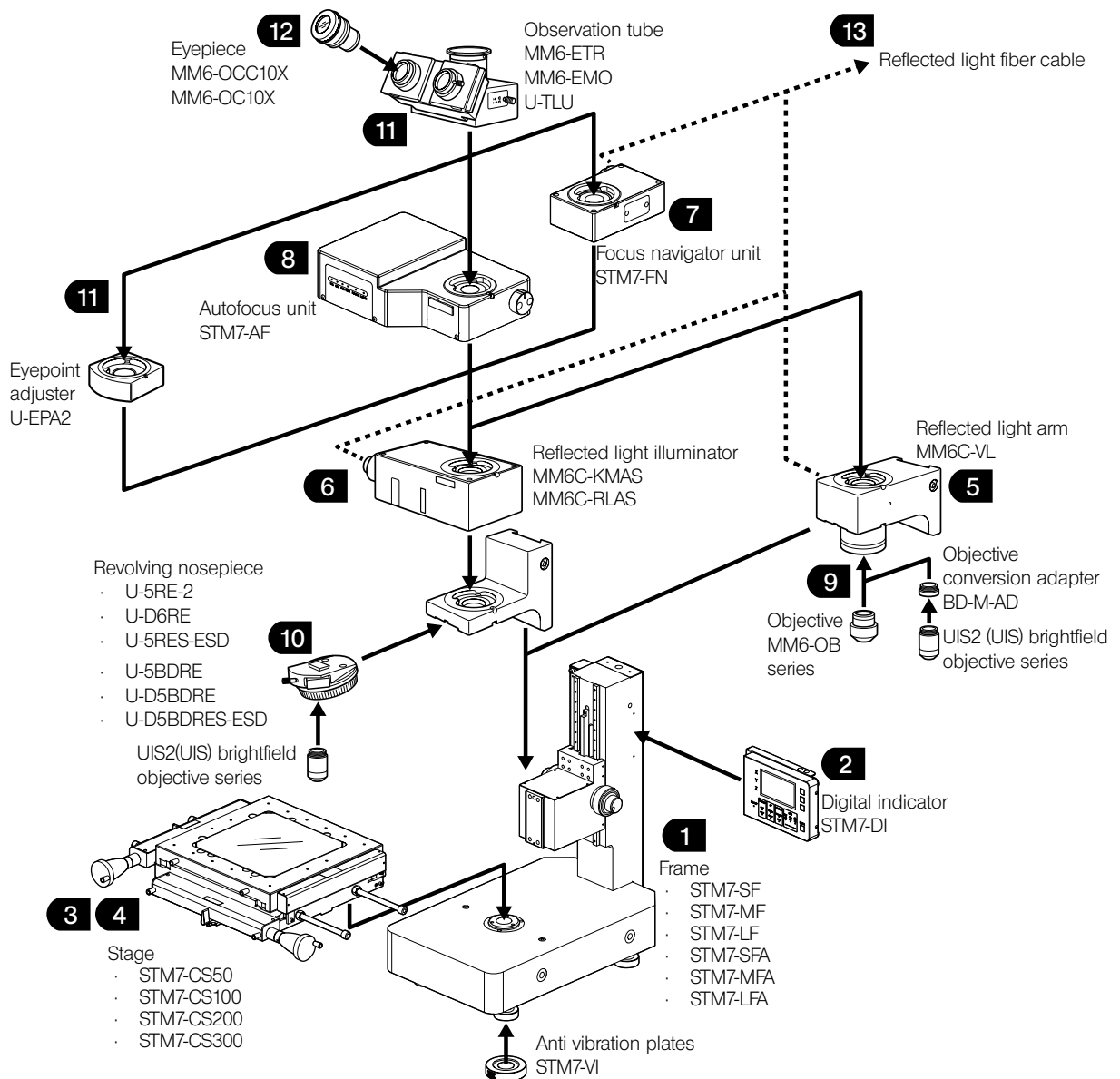

6-2 Detailed assembly procedures

- CAUTION** • Before assembling the microscope, set the main switch of the control box STM7-CB/STM7-CBA to "O" (OFF) and unplug the power cord.
- The frame and the stage are very heavy. Pay a careful attention when carrying them. For the number of transport persons, refer to page 5.

⊙ Unless otherwise specified, the same procedures apply to STM7-SF/STM7-SFA/STM7-MF/STM7-MFA/STM7-LF/STM7-LFA.

1 Frame installation

- CAUTION** • Keep the transport sticks and clamps/screws for Z-axis transport lock in a safe place. They will be used for next transportation.
- Place the frame on a stable horizontal surface.
 - Secure the space (1 m) around the table for workers. If there is no sufficient space, the frame cannot be installed.

⊙ If there is no sufficient space around the table, you can use a movable desk instead.

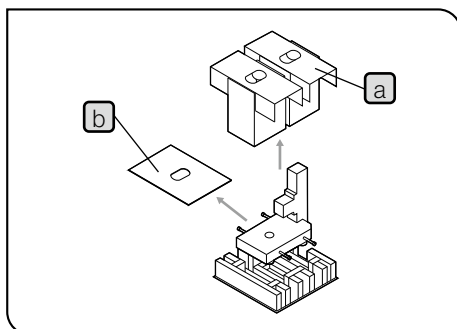

- 1** Take out the sleeve **a** and the protecting sheet **b** from the package box.

- 2** Hold the transport sticks **b** (4 pcs.) to raise the frame and place it on the installation table.
(Frame weight: 51.8 kg (STM7-SF), 53.8 kg (STM7-SFA), 77.1 kg (STM7-MF), 78.6 kg (STM7-MFA), 150.5 kg (STM7-LF), 152 kg (STM7-LFA))

- CAUTION** • Do not hold any part other than the transport sticks. The microscope frame may be damaged.

⊙ If the installation table is dented by the legs of the frame due to the thin top board, or if the microscope is influenced by vibration significantly, place the anti vibration plates STM7-VI (option) under the legs of the frame.

⊙ Be sure to place the legs of the frame in the center of the anti vibration plates.

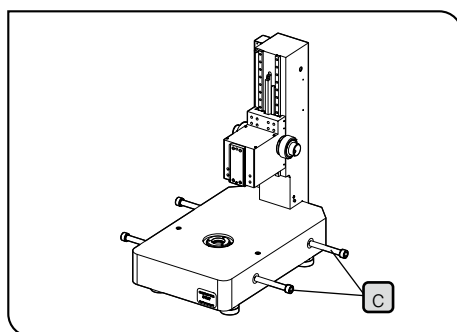

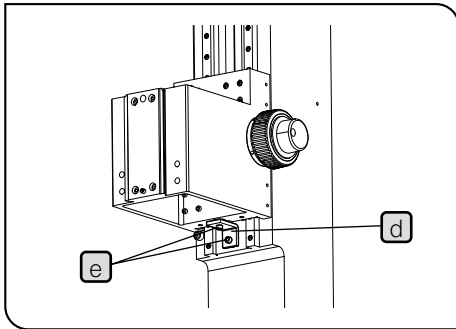

- 3** Loosen the screws **d** (2 pcs.) of the Z-axis transport lock **c** using the Allen wrench provided with the frame, and remove the Z-axis transport lock **c**.

CAUTION When removing the screw, be careful not to drop the screw inside the frame.

- 4** Attach the screws **d** to the frame again.
5 Rotate the transport sticks **b** (4 pcs.) to remove them from the frame.

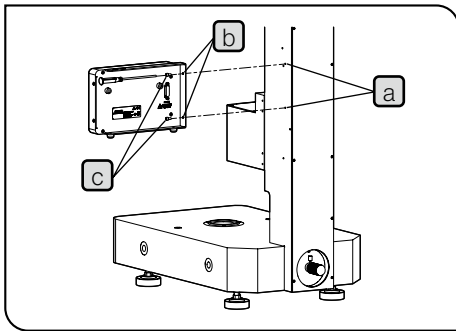

2 Mounting the digital indicator

- 1** Fit the screw holes **a** (2 pcs.) on the right of the column with the screw holes **b** of the digital indicator STM7-DI, and secure the clamping screws **b** (2 pcs.) provided with the digital indicator by using the Allen screwdriver provided with the frame.

CAUTION Hold the digital indicator until it is secured on the column.

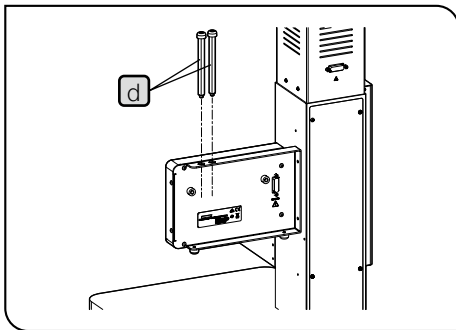

- ⊙ If the digital indicator is attached to the microscope, store the shafts **d** (2 pcs.) provided with the digital indicator on the rear of the digital indicator.
- ⊙ Rotate the rubber area of the shaft to tighten the screw of the rubber area. Then, store the shafts.

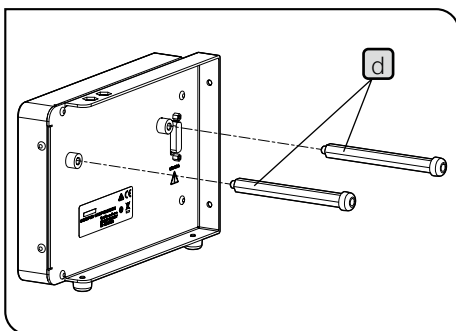

- ⊙ When using the digital indicator on the table, screw the shafts **d** (2 pcs.) provided with the digital indicator into the rear cover of the digital indicator securely.
- ⊙ If the digital indicator is shaky on the table, rotate the rubber area of the shaft to adjust the shaft length.

3 Mounting the stage

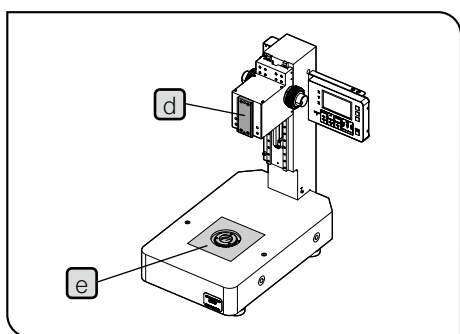
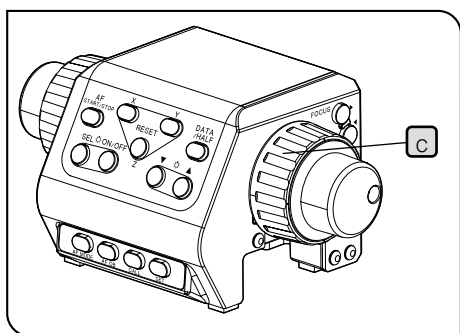
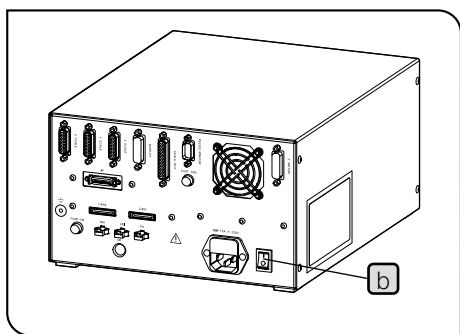
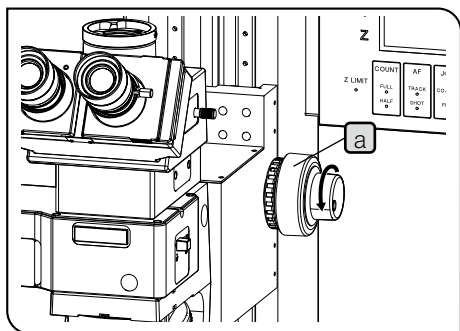

CAUTION • Keep transport rods, transport sticks, and clamps/screws for stage transport lock in a safe place. They will be used for next transportation.

• Sudden or severe impact may exert an adverse effect upon the precision of the microscope. Handle the stage with care and avoid subjecting it to sudden or severe impact.

⊙ When using the manual frame, rotate the coarse focusing knob **a** to raise the focusing unit as much as possible before installing the stage.

⊙ When using the motorized frame, refer to "15 Connecting cable and cords" (page 69) and connect cables and cords. Then, set the main switch **b** of the control box for motorized STM7-CBA to **I**(ON) and rotate the coarse focusing knob **c** of the focusing controller STM7-MCZ to raise the focusing unit as much as possible.

CAUTION When the focusing unit is raised, set the main switch of the control box for motorized to **O**(OFF). Unplug the power cord from the outlet and install the stage.

1 Clean the stage mounting surface of the frame.
For cleaning procedures, see "Maintenance and storage" (page 12).

CAUTION • Dust on the stage may hinder the product performance to be manifested fully.

• Remove the anti-rust sheet **d** and the protective film **e** of the frame.

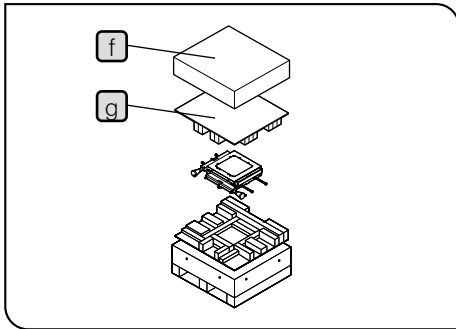

2 In case of STM7-CS200 or STM7-CS300, take out the inner box **(f)** from the packaging box.

3 Take out the protecting sheet **(g)** from the packaging box.

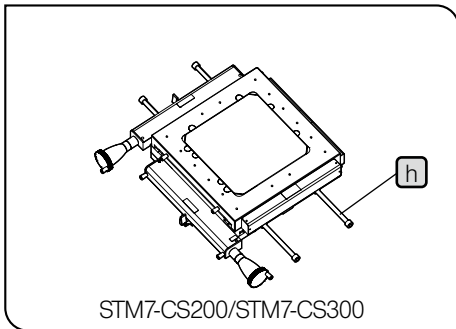

4 In case of STM7-CS200 or STM7-CS300, take out the stage by holding the transport sticks **(h)** (4 positions).

In case of STM7-CS50 or STM7-CS100, take out the stage by holding the transport rods **(i)** (2 positions).

(Stage weight: 18.1 kg (STM7-CS50), 17.7 kg (STM7-CS100), 59.8 kg (STM7-CS200), 111.3 kg (STM7-CS300))

CAUTION • Do not hold any part other than transport rods or transport sticks. The stage may be damaged.

• Remove the anti-rust sheets on the top surface and the bottom surface of the stage.

5 Place only the half of the stage on the installation table and wipe the attaching surface clean.

CAUTION In STM7-CS50 or STM7-CS100, the Y-axis knob is protruded below from the stage mounting surface. Be careful not to allow the Y-axis to touch the installation table.

6 Place the attaching surface wiped on the stage attaching surface of the frame. Wipe the other half of the attaching surface clean.

CAUTION While wiping the stage, one or more installation workers must support the stage by holding the transport rods or the transport sticks.

7 Place the stage gently on the frame by aligning the mounting surfaces.

© While looking from the stage glass, fit the center of the stage with the center of the window lens for transmitted light illumination of the frame.

CAUTION When placing the stage, be careful not to make the stage collide with the glass surface of the frame.

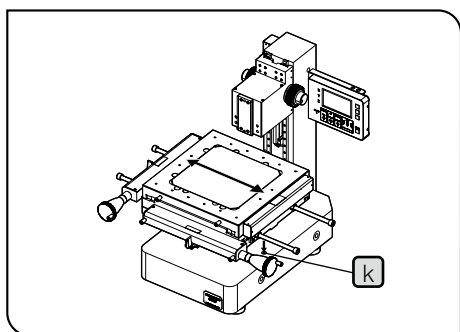
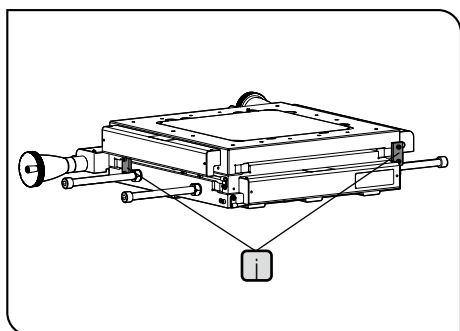

8 Loosen the clamping screws of the stage transport locks **(i)** (2 positions) with the Allen wrench provided with the frame, and remove the locks.

⊙ In case of STM7-CS50 or STM7-CS100, the stage transport locks are attached to the lower front area and the right side of the stage.

⊙ In case of STM7-CS200 or STM7-CS300, the stage transport locks are attached to the rear side and the right side of the stage.

9 Move the X- and Y-axes of the stage, insert the clamping screws **(k)** provided with the stage into the mount holes on the stage base, and clamp the screw using the Allen screwdriver provided with the stage.

A number of clamping screws for STM7-CS50, STM7-CS100 or STM7-CS300 is 4 pieces and 2 pieces for STM7-CS200 respectively.

CAUTION • Hold the transport sticks or transport rods when aligning the screw positions (for malfunction may occur if any other part of the stage is subjected to strong force).

• Be careful not to drop the clamping screws when inserting them.

10 In case of STM7-CS200 or STM7-CS300, remove the transport sticks **(h)** (4 positions) by rotating.

In case of STM7-CS50 or STM7-CS100, remove the transport rods **(i)** (2 positions) from the stage with the Allen wrench provided with the stage.

STM7-RS100/STM7-RS200/STM7-RS300

When the rotatable stage is placed on the stage, the specimen on it can be rotated so the parallelism can be adjusted easily.

CAUTION • Remove any oil, dirt and stain from the bottom surface of the rotatable stage.

• When placing the rotatable stage, be careful not to hit the glass on the stage.

• When carrying the rotatable stage, hold it by putting your hand on the groove on the side surface of the base of the rotatable stage. Do not hold any other parts.

1 Place the rotatable stage **(a)** gently on the center of the table **(b)**.

⊙ Align the X/Y directions of the rotatable stage **(a)** precisely with those of the stage **(b)**. The attaching holes and the attaching screw holes should coincide now.

2 Using the Allen wrench (small) provided with the frame, firmly tighten the 2 clamping screws **(c)** provided with the rotatable stage.

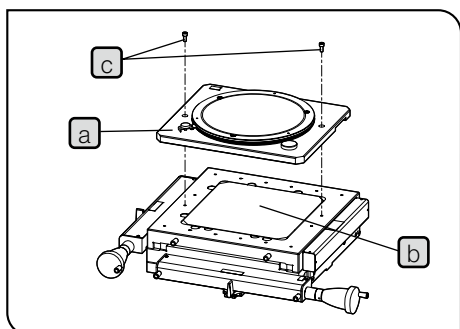

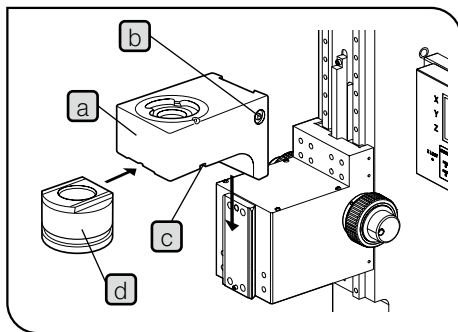
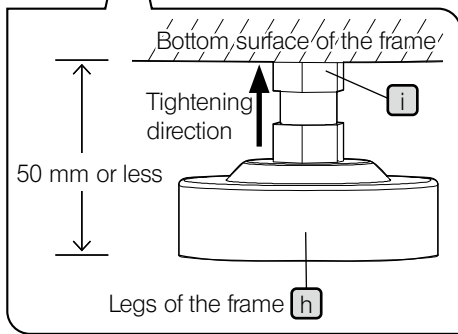
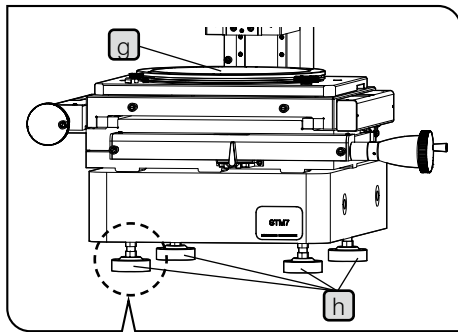

4 Leveling the stage

- 1 Place the level provided by the sales office on the stage glass **q**.
- 2 Adjust the legs **h** (2 each on front and back) of the frame to level front/back/right/left by using the spanner.

When the X-axis or Y-axis clutch is released with the stage position as a center position, make sure that the stage does not move spontaneously in either X or Y direction.

Ⓞ When the microscope is assembled after completing the setup of the camera, etc., perform the leveling again.

CAUTION • Adjust the legs **h** of the frame within the range of 50 mm or less from the bottom surface of the frame. If adjusting the legs exceeding this range, the microscope may be overturned.

- When adjusting the legs of the frame, loosen the fixing nuts **i** shown at the upper area in the picture on the left.
- After the legs are adjusted, be sure to tighten the fixing nuts **i** shown at the upper area in the picture on the left completely until it touches the bottom surface of the frame.

5 Mounting the brightfield reflected light arm (MM6C-VL)

- 1 Fully loosen the clamp **b** (stud) of the reflected light arm **a** using the Allen screwdriver provided with the frame.
- 2 Fit the reflected light arm **a** into the mount dovetail on the frame all the way until it is stopped. Take care that the reflected light arm is not tilted.
- 3 Tighten the clamp **b** (stud) of the reflected light arm **a** using the Allen screwdriver provided with the frame.
- 4 Fully loosen the objective seat mount screw **c** on the right of the reflected light arm **a** using the Allen screwdriver provided with the frame.
- 5 Fit the mount dovetail of the objective seat **d** into the objective seat mount on the reflected light arm **a** all the way until it is stopped.
- 6 Tighten the objective seat mount screw **c** using the Allen screwdriver provided with the microscope frame.

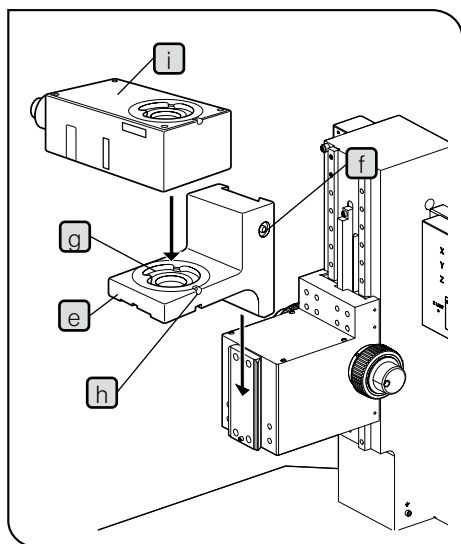

6 Mounting the reflected light illuminator (MM6C-KMAS, MM6C-RLAS)

- 1 Fully loosen the clamp **f** (stud) of the reflected light arm **e** using the Allen screwdriver provided with the frame.
- 2 Fit the reflected light arm **e** into the mount dovetail on the frame all the way until it is stopped. Take care that the reflected light arm is not tilted.
- 3 Tighten the clamp **f** (stud) of the reflected light arm **e** using the Allen screwdriver provided with the frame.
- 4 Fully loosen the clamping screw **h** of the round dovetail **g** (female) on the reflected light arm **e**.
- 5 Fit the round dovetail on the reflected light illuminator **i** into the round dovetail **g** of the reflected light arm **e** so that the reflected light illuminator faces toward the left (i.e. the fiber cable mount comes on the left).
- 6 Tighten the clamping screw **h** of the reflected light arm **e** using the Allen screwdriver provided with the frame.

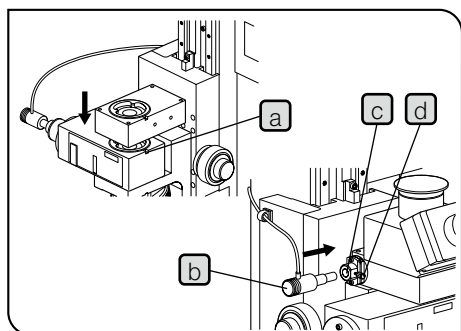

7 Mounting the focus navigator unit

- 1 Fully loosen the observation tube clamping screw **a** using the Allen screwdriver provided with the frame, attach the circular mount dovetail on the bottom of the focus navigator unit, and then tighten the clamping screw again.
- 2 Insert the green LED unit (MM6-ILG) **b** into the LED unit installation block **c** of the frame and clamp it with the clamping knob **d**.

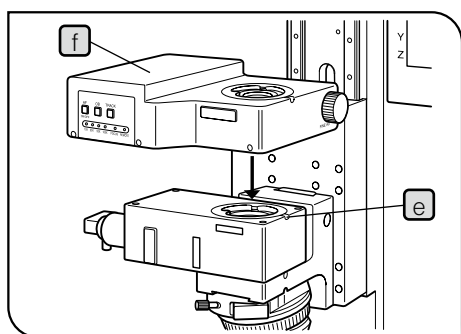

8 Mounting the autofocus unit

⊙ The autofocus unit can be mounted only on the motorized frame.

- 1 Fully loosen the observation tube clamping screw **e** using the Allen screwdriver provided with the frame, attach the circular mount dovetail on the bottom of the autofocus unit **f**, and then tighten the clamping screw again.

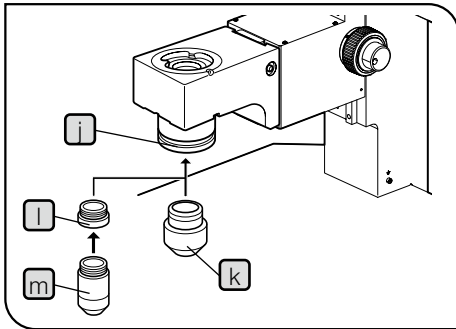

9 Mounting the objective (MM6C-VL)

- ⊙ When using the reflected light arm MM6C-VL, only one objective can be attached because the reflected light arm does not use a revolving nosepiece.

MM6-OB series objective

Mount the desired MM6-OB series objective **k** into the objective mount **i** by screwing in firmly.

UIS2 (UIS) brightfield series objective

Screw in the objective conversion adapter BD-M-AD **l** into the objective mount **i**, then mount the desired UIS2 (UIS) brightfield objective **m** on the BD-M-AD by screwing in firmly.

CAUTION • The UIS2 (UIS) brightfield/darkfield objective cannot be used because this results in flare.

- Do not attach the objective to the objective lens mount that has been removed from the reflected light arm, or do not attach the removed objective lens mount, with the objective mounted, back to the reflected light arm.

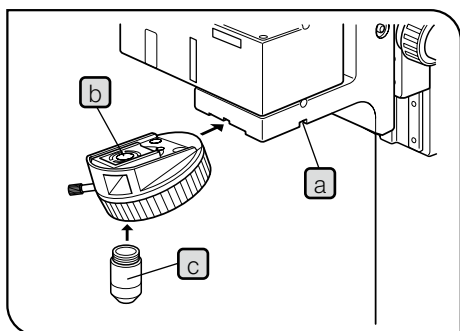

10 Mounting the revolving nosepiece/objectives (MM6C-KMAS, MM6C-RLAS)

- 1 Loosen the revolving nosepiece clamping screw **a** on the reflected light arm using the Allen screwdriver provided with the microscope frame.
- 2 Fit the mount dovetail **b** of the revolving nosepiece gently into the revolving nosepiece attaching area on the reflected light arm and push in all the way until it is stopped.
- 3 Tighten the revolving nosepiece clamping screw **a** using the Allen screwdriver provided with the microscope frame, and mount the desired UIS2 (UIS) objectives **c** by screwing in firmly.

⊙ It is recommended to mount objectives in order from low-magnification to high-magnification objectives. In this way, it will be easy to change the magnification later.

When using the coded revolving nosepiece

⊙ Before mounting the nosepiece, remove the reflected light arm from the microscope frame. (see page 62)

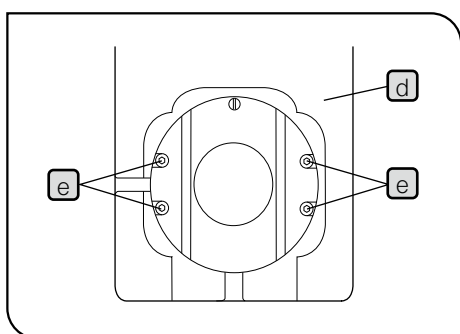

- 1 Loosen and remove the screws **e** (4 pcs.) of the revolving nosepiece mount on the reflected light arm **d** using the Allen screwdriver provided with the microscope frame.
- 2 Turn the revolving nosepiece mount **f** 90 degrees.
- 3 Fix the revolving nosepiece mount by tightening the screws **e** (4 pcs.) using the Allen screwdriver.
- 4 After mounting the reflected light arm **d** on the microscope frame, fit the coded revolving nose into the mount from left side.
- 5 Mount the desired UIS2 (UIS) objectives by screwing in firmly.

When using the measurement objective

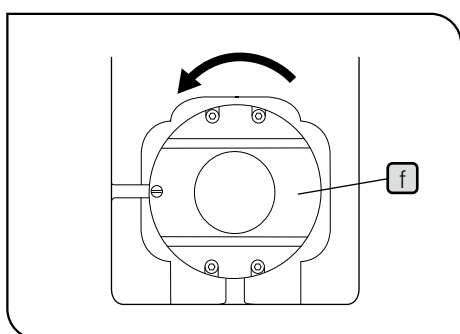

- 1 Loosen the clamping screws **g** of the reflected light arm sufficiently using the Allen screwdriver provided with the frame.
- 2 Insert the dovetails of the adapter to mount measuring objectives STM7-MMOBAD **h** into the objective attaching area of the reflected light illuminator arm from the front. And push it until it touches the end.
- 3 Tighten the clamping screws **g** of the reflected light arm securely using the Allen screwdriver provided with the frame.
- 4 Screw the objective securely into the objective **i** attaching area.

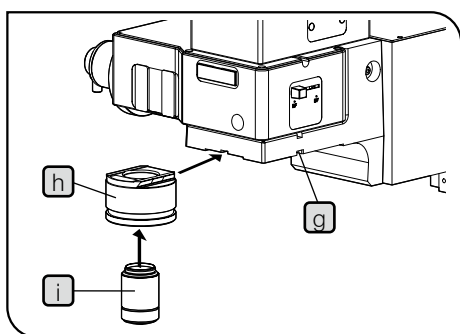

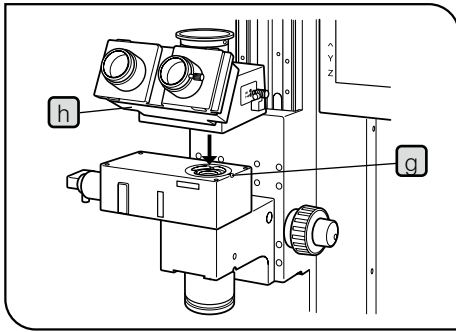

11

Mounting the Observation Tube (MM6-EMO, MM6-ETR, U-TLU)

- 1 Fully loosen the tube clamping screw **g** using the Allen screwdriver provided with the microscope frame.
 - ⊙ When using the autofocus unit STM7-AF, fully loosen the tube clamping screw of the autofocus unit using the Allen screwdriver provided with the microscope frame.
- 2 Fit the round dovetail at the bottom of the observation tube **h** into the mount on the reflected light arm.
 - ⊙ When using U-TLU, make the positioning reticle facing the front.
- 3 Tighten the tube clamping screw using the Allen screwdriver provided with the frame.

When using the eyepoint adjuster

- ⊙ Only for the large frame STM7-LF/STM7-LFA, the eye point adjuster U-EPA2 can be attached to the microscope up to 2 levels in the same way as other intermediate tubes.

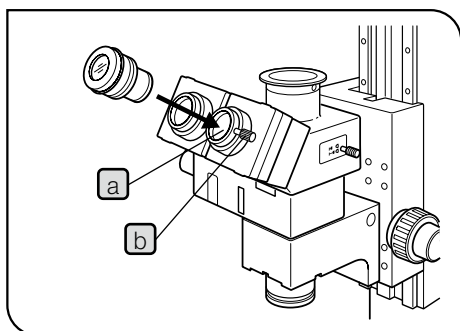

12 Mounting the eyepiece

CAUTION • The MM6-OCC10X eyepiece with cross hairs should always be attached to the right microscope sleeve (in case of a binocular tube).

• Use the MM6-OCC10X eyepiece for the erect image monocular observation tube MM6-EMO.

- 1** Loosen the clamping knob **b** of the right eyepiece sleeve using the tool provided with the frame and insert the MM6-OCC10X carefully into the sleeve **a**.
- 2** When the cross hairs and the stage travel in the XY direction are adjusted, tighten the clamping knob **b** using the tool provided with the frame.
 - ⊙ If you want to use a clamping knob without tab, tighten the clamping knob provided with MM6-ETR/MM6-EMO using the dedicated Allen screwdriver.

CAUTION Do not tighten the clamping knob too firmly.

- 3** Insert the MM6-OC10X into the left eyepiece sleeve.

CAUTION At this stage, clamp the eyepiece sleeves temporarily and lightly. When the microscope is assembled after completing the setup of the light source, etc., perform the following adjustments.

Adjusting the cross hairs and X- and Y-travel direction of stage

Place a test bar or a straight edge on the table approximately parallel with the table travel direction, then adjust the positioning so that the intersection of the eyepiece cross hairs comes on the straight line of the test bar.

Next, rotate the eyepiece on the parallel straight line to align the cross hairs, and tighten the clamping knob.

- ⊙ When the AF unit is combined with the MM6C-KMAS or MM6C-RLAS, the periphery of the observation field of view may become dark. If this bothers you, replace the cross-frame part of the eyepiece with that provided with the autofocus unit.

CAUTION The MM6-OCC10X incorporates a focusing plate. Take care not to leave dirt or stains on the focusing plate when replacing the crossframe. Also, when detaching and attaching the cross-frame unit, stand the eyepiece so that the focusing plate does not drop.

Replacing the cross-frame

- 1** Remove the cross-frame **c** built into the MM6-OC10X or MM6-OCC10X eyepiece by rotating the cross-frame.
- 2** Attach the cross-frame provided with the autofocus unit to the eyepiece.
 - ⊙ With the MM6-OCC10X, drop the focusing plate **d** into the cross-frame so that the focusing plate's indication surface faces down, and then screw the cross-frame onto the eyepiece.

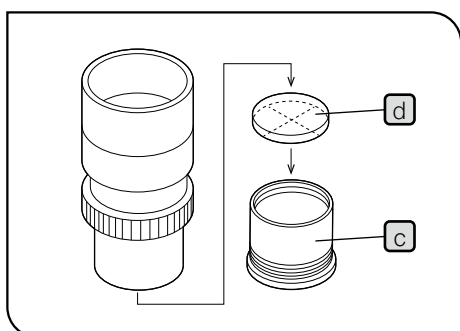

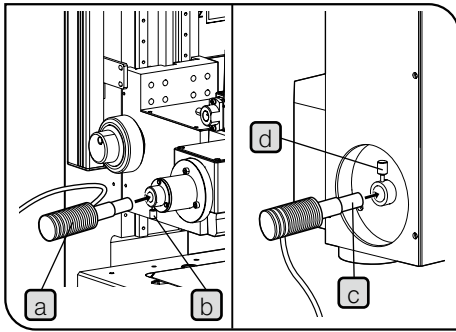

STM7-SF/STM7-SFA/STM7-MF/STM7-MFA

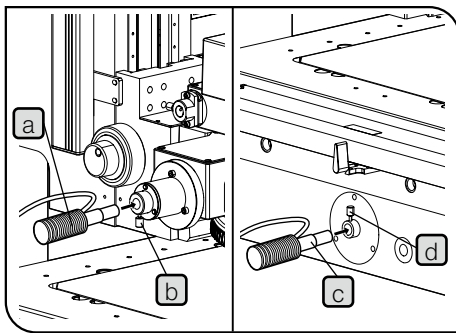

STM7-LF/STM7-LFA

13 Connecting the LED light to the output end (MM6-ILW, MM6-ILG)

CAUTION Cables and cords are vulnerable when bent or twisted. Never subject them to excessive force.

- 1 Insert the white LED unit (MM6-ILW) **a** into the port on the reflected light unit and clamp with the clamping knob **b**.
- 2 Insert the green LED unit (MM6-ILG) into the frame.

STM7-SF/STM7-SFA/STM7-MF/STM7-MFA

Insert the green LED unit (MM6-ILG) **c** into the lower part on the rear of the frame, and clamp with the clamping knob **d**.

STM7-LF/STM7-LFA

Insert the green LED unit (MM6-ILG) **c** into the lower part on the left side of the frame, and clamp with the clamping knob **d**.

14 Mounting the digital camera

CAUTION • The camera head and camera adapter are precision modules. Be careful not to drop them during attaching or detaching.
• Keep the dust cap in a safe place. It will be used for next transportation.

◎ The following procedure deals with the case using the U-TV1XC C-mount camera adapter.

- 1 Rotate the dust cap **e** of the camera to remove.
- 2 Screw in the U-TV1XC C-mount camera adapter **f** into the extension ring **g** at the bottom of the camera head.
- 3 Attach the C-mount camera adapter to the camera port of the microscope.

CAUTION Attach the camera adapter to the camera port so that the connector **h** of the digital camera comes to the right side.

◎ If the camera is attached in a wrong direction, the direction of the image observed through the eyepiece does not match with the direction of the image through the camera. After the camera is installed, compare the image observed through the eyepiece to the live image acquired by the camera, and rotate the camera adapter to match these images. For details, refer to "7-1 Adjusting the tilt of the camera" (page 81).

CAUTION When removing the camera from the camera adapter, be careful not to allow the extension ring **g** removed from the camera.

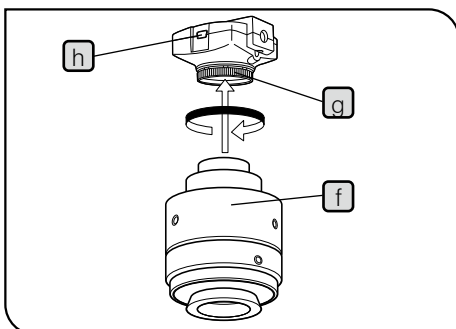
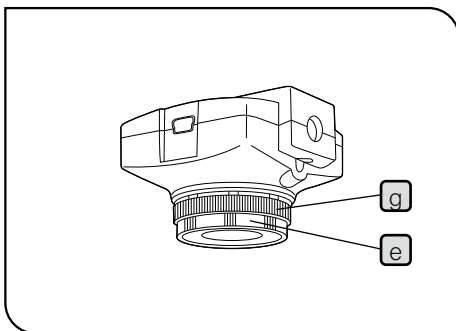

15 Connecting cable and cords

- CAUTION**
- Cables and cords are vulnerable when bent or twisted. Never subject them to excessive force.
 - Make sure that the main switches of the power supply devices are set to “○” (OFF) before connecting the power cord.
 - Always use the power cords or functional ground cables provided by Evident. If no power cord is provided, please select the proper power cord by referring to the section “Proper selection of the power supply cord” at the end of this instruction manual.
 - If the cable is equipped with the mounting screw, be sure to tighten the mounting screw before using the system. If you use the cable without tightening the mounting screw, the malfunction or the failure is caused by the connection failure of cables.

- ◎ The assembly procedures are illustrated in combination with the middle motorized frame as a reference. Unless otherwise specified, the same applies to other combinations.
- ◎ If there are connection alternatives, connect to the connector of the module you will use.
- ◎ For connections of positions with * mark, contact Evident for details.

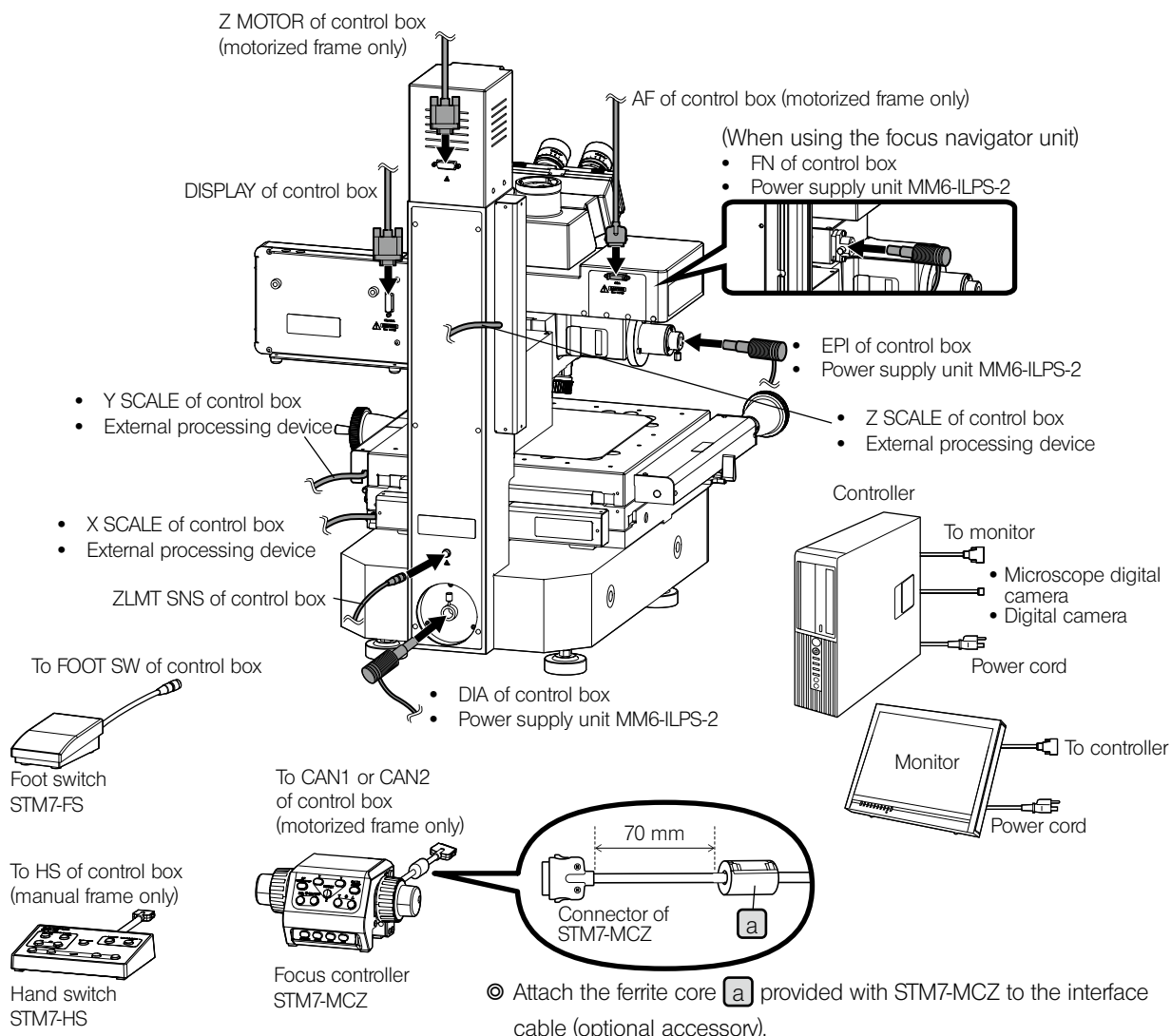

External processing device (DSUB25Pin Female)*

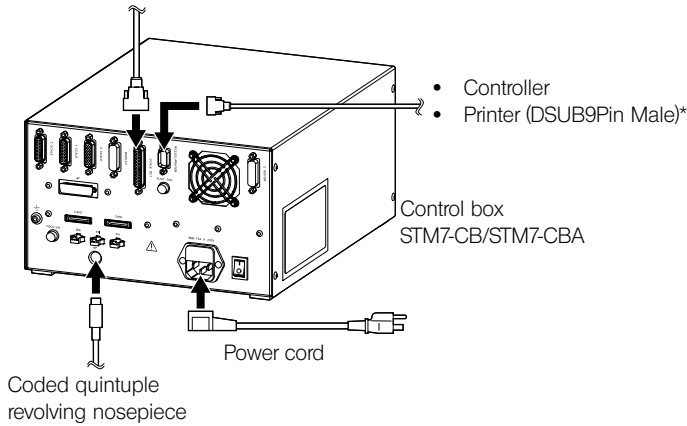

- ⊙ If no instruction is specified to the connector, the cables from the frame, stage or other modules are connected.
- ⊙ For connections of positions with * mark, contact Evident for details.

- CAUTION**
- When connecting DISPLAY of the control box with the digital indicator, check the pin positions of the connector of the cable for digital indicator.
 - When connecting Z-MOTOR of the control box with the motorized frame, check the pin positions of the connector of the cable for motorized frame.

⊙ Since the length or the shape of cables is similar, distinguish them by the pin positions of the connector.

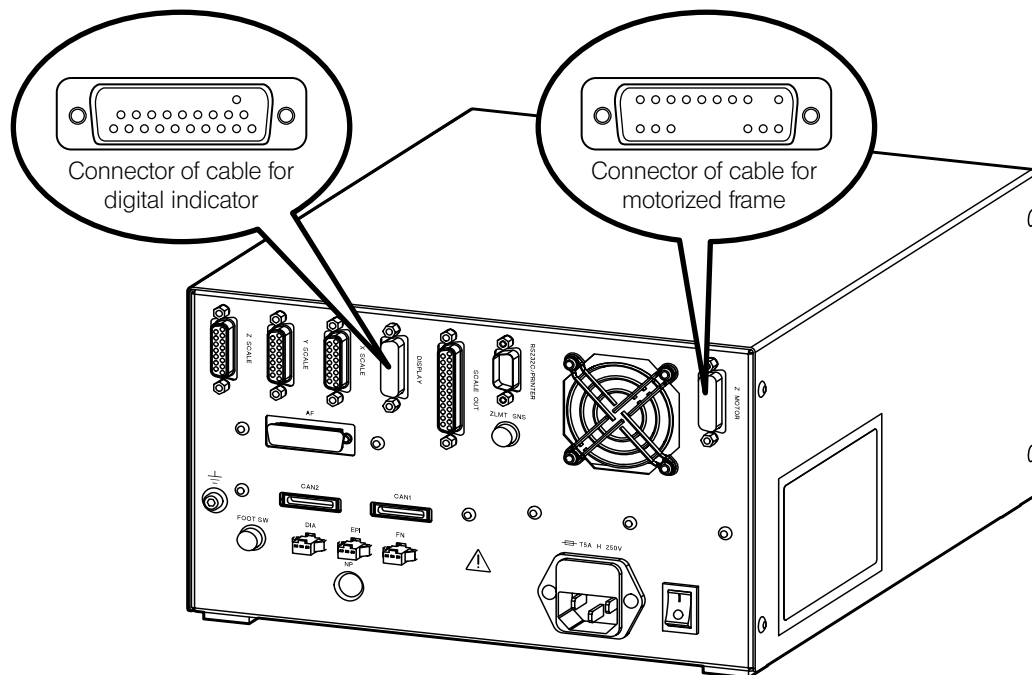

CAUTION For product safety, connect the round-shape terminals of the functional ground cables to the \perp mark area between the stage and the frame and between the frame and the control box, and tighten the screws with the Allen screwdriver provided with the microscope frame.
 (In case of STM7-CS50 or STM7-CS100, the connection destination of the functional ground cable is at the rear of the stage.)

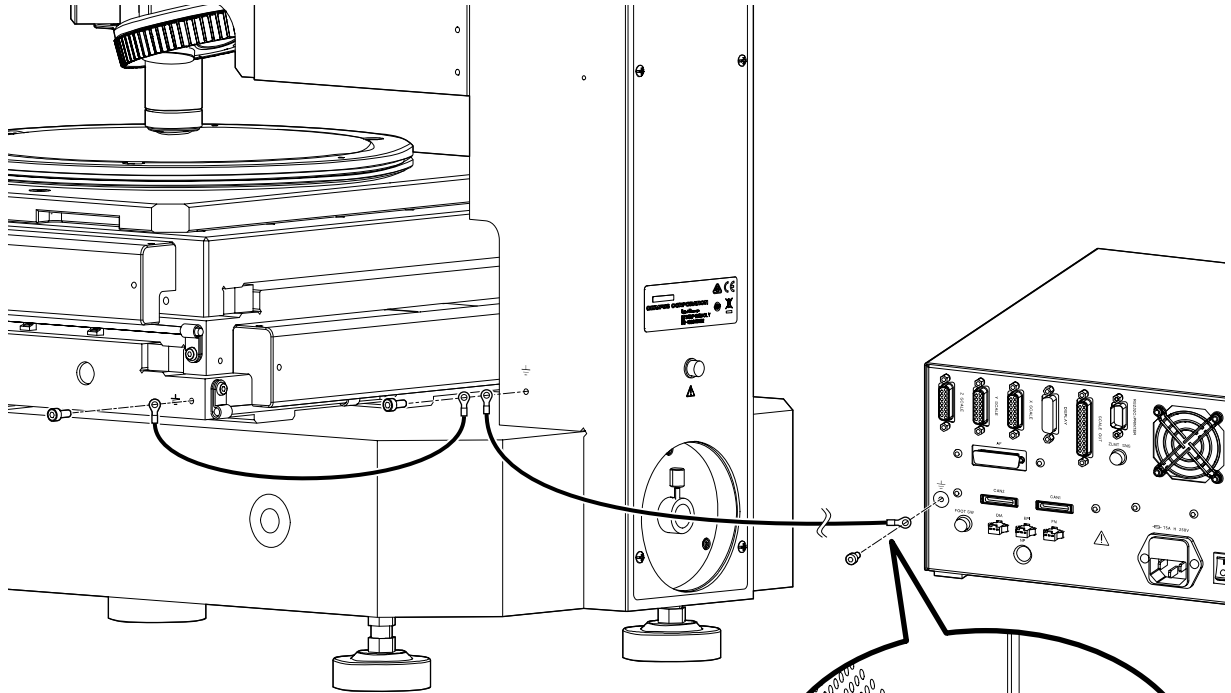

CAUTION Bend the functional ground cables so that the excess force is not applied to the foot of the round shape terminal or the bonding area of the round shape terminal and also they do not collide with other cables or cords.

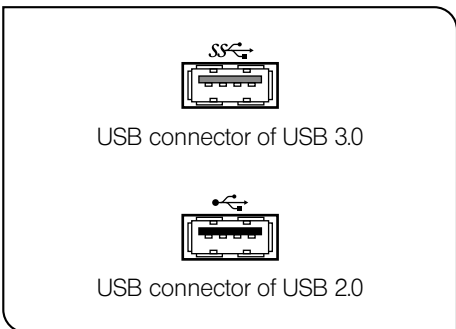
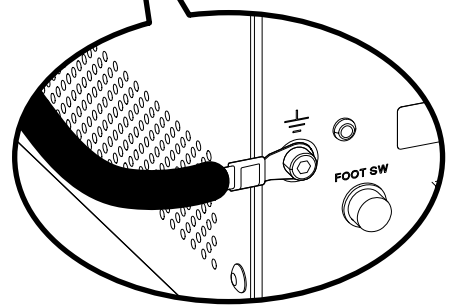

CAUTION When connecting interface cables of the microscope digital camera DP22/DP23/DP27/DP28 to the controller, connect them to the connector of USB 3.0/USB3.1.

When connecting USB cables of digital camera STM7-CU to the controller, connect them to the connector of USB 2.0.

If they are connected incorrectly, the camera does not work.

© For the connector of USB 3.0, the terminal may be blue or it is printed as "SS" depending on controllers.

16 Cable distributions

CAUTION Bundle the cables loosely giving plenty of length so that they won't be stretched when operable parts move. Particularly, do not bundle the cables connected to the stage or the focusing unit with tension in all movement ranges.

- ⊙ The cable distribution is illustrated in combination with the large motorized frame as a reference. Unless otherwise specified, the same applies to other combinations.
- ⊙ Attach the cable holder to the position illustrated in the picture and distribute the cables.

Front view of microscope
(when combined with DP22/DP23/DP27/DP28)

Fit the cables in the cable holder **a**, giving the cable a certain slack so that it does not hinder the vertical movement of the Z-axis.

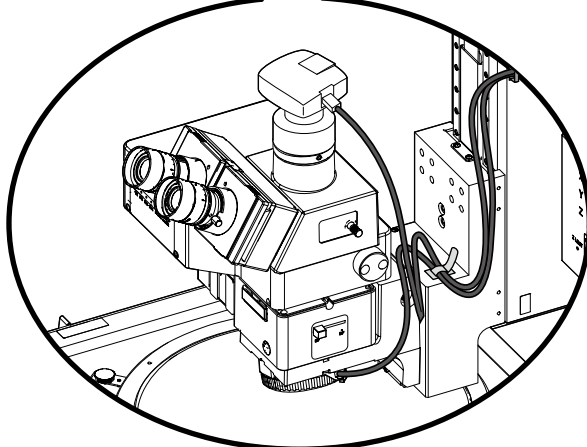
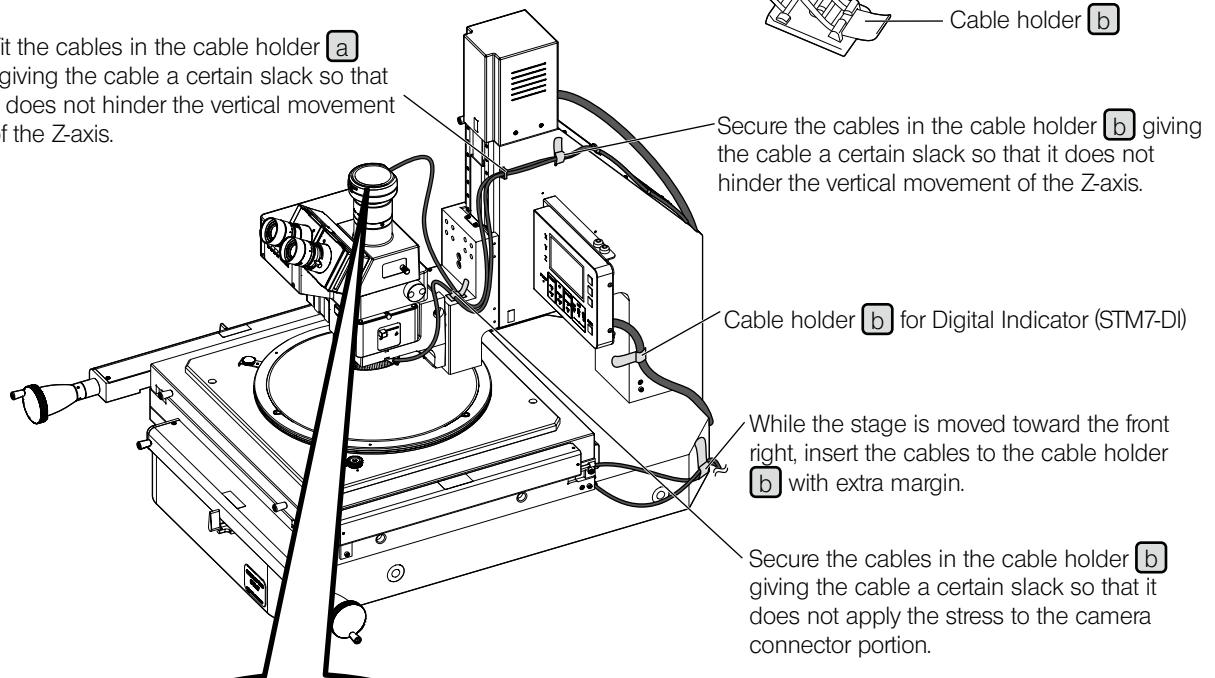
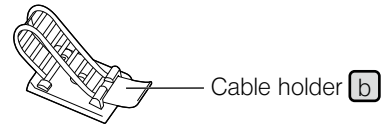
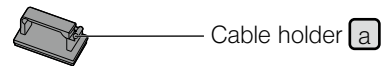

Front view of microscope (when combined with STM7-CU)

- ⊙ Explanations other than the camera connector position are same as the case when combined with DP22/DP23/DP27/DP28.

Camera connector position

DP22/DP23/DP27/DP28: Back side

STM7-CU: Right side

Back view of microscope

Fit the cables of the autofocus unit (STM7-AF), the focus navigator unit (STM7-FN) and/or the white LED unit (MM6-ILW) in the cable holder **a**, giving the cable a certain slack so that it does not hinder the vertical movement of the Z-axis.

Fit the Z-scale cable in the cable holder **b**, giving the cable a certain slack so that it does not hinder the vertical movement of the Z-axis.

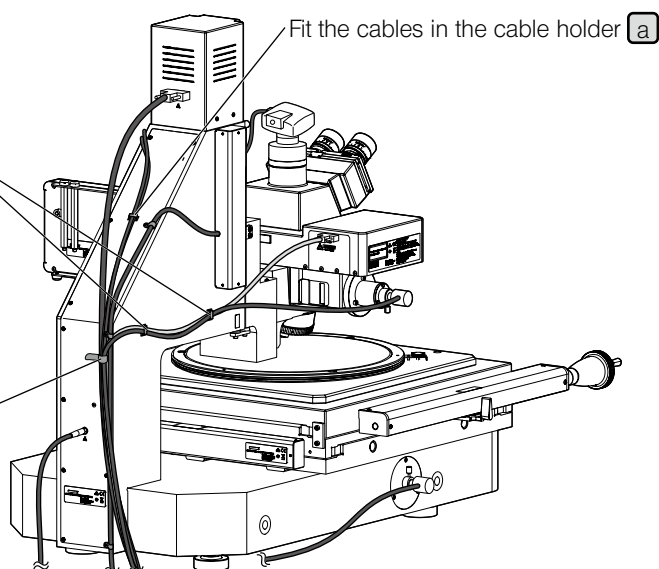

- ⊙ The cable holder and the magic tape are provided with the frame.
- ⊙ Bundle the cables with the magic tape at last.
- ⊙ When all assemblies are completed, make sure the counting status of X-,Y- and Z-axis, unit of the counter display, operations of X- and Y-axis knobs, Z-axis driving, operations of the hand switch STM7-HS or the focus controller STM7-MCZ, etc.

17 Replacing fuses

CAUTION • Before replacing the fuses, set the main switch of the control box STM7-CB/STM7-CBA whose fuse will be replaced to “O” (OFF) and unplug the power cord.

• Always use the specified fuses. Using other fuses than specified may result in fire hazard.

- 1** The fuse holders **b** are located near the power cord connector on the rear of the control box **a**. They can be removed by using a flat-blade screwdriver.

Always replace both of the 2 fuses with new fuses.

Applicable fuses: |  T5 A H 250 V (LITTELFUSE 0215005.MXP)

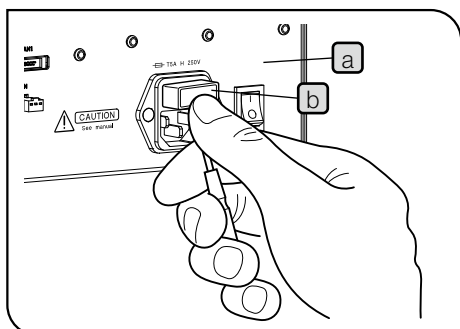

6-3 Inputting setting values (maker setting mode)

CAUTION • Setting values must be inputted by Evident. Do not change the setting values by yourselves.

• Values of "Standard value" and "Measured value" described in Certificate of Accuracy are setting values assured when shipping the product. If the setting values are not inputted or the values different from those described in Certificate of Accuracy are set, the accuracy is not assured even in the accuracy assurance environments. For accuracy assurance environments, refer to page 89.

Ⓢ When the microscope is assembled, input the setting values. If the setting values are not inputted, an error sound beeps (three short beeps) when the main switch of the control box STM7-CB/STM7-CBA is set to **I**(ON). (If you are using the control box for motorized STM7-CBA and also the origin search setting is ON, the error sound beeps when the origin search is finished.)

Ⓢ To input the setting values, the values of X-, Y- and Z-axis described in Certificate of Accuracy provided with the frame or the stage are required. Prepare Certificate of Accuracy at hand.

CAUTION • Do not change the items not related to settings. If you change the factory default settings, the system may not count or the motorized frame may not be driven in Z direction, etc. However, this is not a failure of the microscope.

If you change the settings by mistake, start the maker setting mode to set the correct settings, save the setting values and exit.

Ⓢ When you are not using the digital indicator STM7-DI, the maker setting mode can be started with the Excel transfer tool downloaded from the Evident website. For details, refer to the Help of the Excel transfer tool.

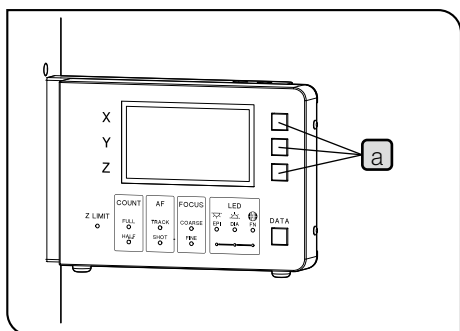

- 1** While pressing the X-, Y- and Z-RESET buttons **a** of the digital indicator at the same time, set the main switch **b** of the control box STM7-CB/ STM7-CBA to **↑** (ON).

Keep pressing the X-, Y- and Z-RESET buttons, and wait for approx. 3 seconds. The microscope starts in the maker setting mode.

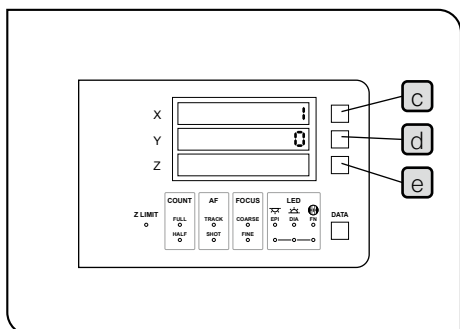
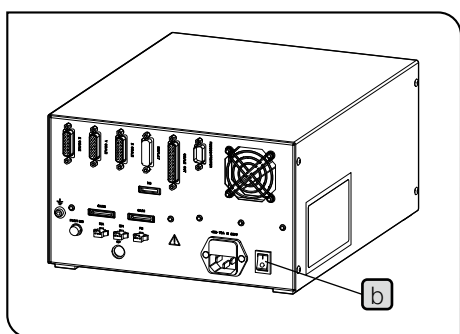

2 Setting the X-axis counting direction

While display X shows "1", press the Y-RESET button **d** or the Z-RESET button **e** to set the X-axis counting direction in the display Y.

☉ For setting values, see "2 Setting Function List" (page 79).

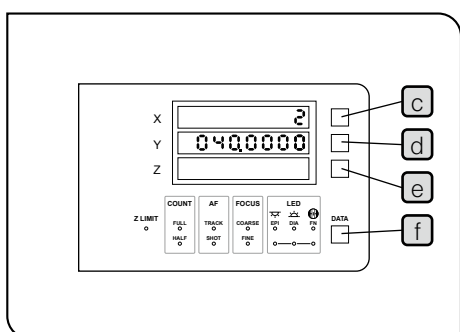

3 Inputting the standard value of X-axis

1. Press the X-RESET button **c** to show "2" in the display X.
2. Press the DATA button **f** to change the digit you want to edit in the display Y.
3. Press the Y-RESET button **d** or the Z-RESET button **e** to set the display Y to "Standard value" of "X-axis" described in Certificate of Accuracy (provided with the stage).

☉ The unit of values in the display Y is mm.

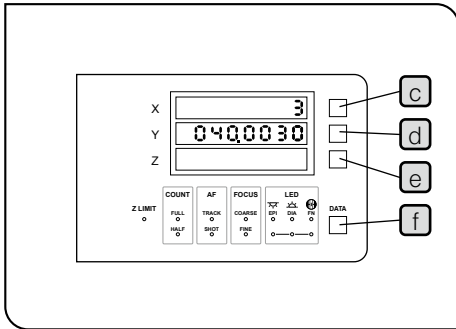

4 Inputting the measured value of X-axis

1. Press the X-RESET button **c** to show "3" in the display X.
2. Press the DATA button **f** to change the digit you want to edit in the display Y.
3. Press the Y-RESET button **d** or the Z-RESET button **e** to set the display Y to "Measured value" of "X-axis" described in Certificate of Accuracy (provided with the stage).

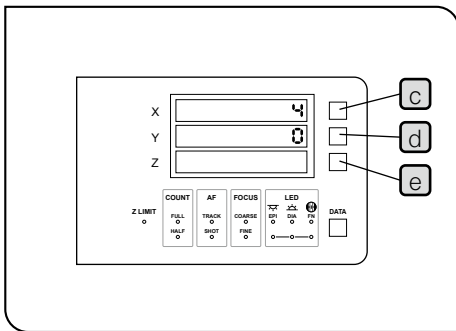

5 Setting the Y-axis counting direction

1. Press the X-RESET button **c** to show "4" in the display X.
2. Press the Y-RESET button **d** or the Z-RESET button **e** to set the Y-axis counting direction in the display Y.

© For setting values, see "2 Setting Function List" (page 79).

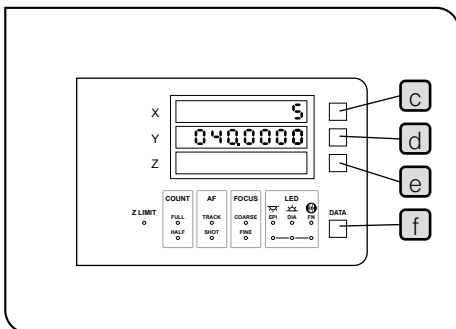

6 Inputting the standard value of Y-axis

1. Press the X-RESET button **c** to show "5" in the display X.
2. Press the DATA button **f** to change the digit you want to edit in the display Y.
3. Press the Y-RESET button **d** or the Z-RESET button **e** to set the display Y to "Standard value" of "Y-axis" described in Certificate of Accuracy (provided with the stage).

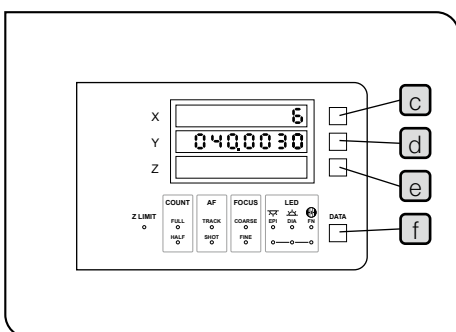

7 Inputting the measured value of Y-axis

1. Press the X-RESET button **c** to show "6" in the display X.
2. Press the DATA button **f** to change the digit you want to edit in the display Y.
3. Press the Y-RESET button **d** or the Z-RESET button **e** to set the display Y to "Measured value" of "Y-axis" described in Certificate of Accuracy (provided with the stage).

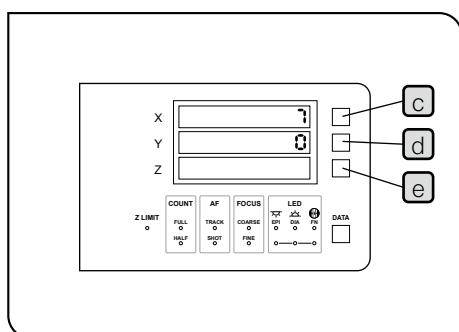

8 Setting the Z-axis counting direction

1. Press the X-RESET button **c** to show "7" in the display X.
2. Press the Y-RESET button **d** or the Z-RESET button **e** to set the Z-axis counting direction in the display Y.

© For setting values, see "2 Setting Function List" (page 79).

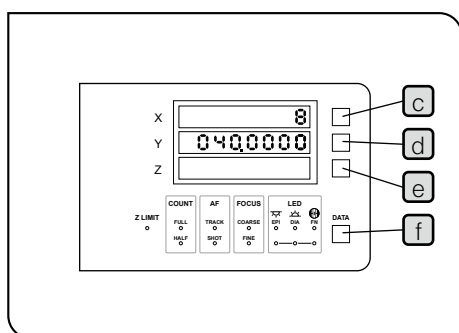

9 Inputting the standard value of Z-axis

1. Press the X-RESET button **c** to show "8" in the display X.
2. Press the DATA button **f** to change the digit you want to edit in the display Y.
3. Press the Y-RESET button **d** or the Z-RESET button **e** to set the display Y to "Standard value" of "Z-axis" described in Certificate of Accuracy (provided with the frame).

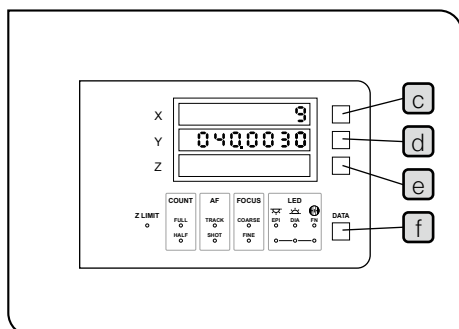

10 Inputting the measured value of Z-axis

1. Press the X-RESET button **c** to show "9" in the display X.
2. Press the DATA button **f** to change the digit you want to edit in the display Y.
3. Press the Y-RESET button **d** or the Z-RESET button **e** to set the display Y to "Measured value" of "Z-axis" described in Certificate of Accuracy (provided with the frame).

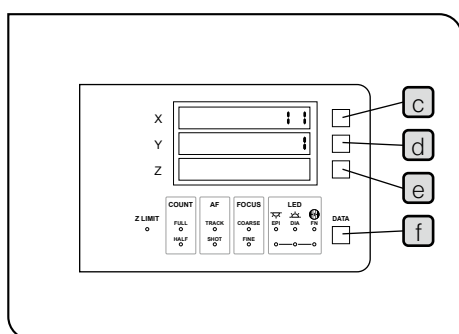

11 Saving setting values

1. Press the X-RESET button **c** to show "11" in the display X.
2. Press the Y-RESET button **d** or the Z-RESET button **e** to show "1" in the display Y.
3. Press the DATA button **f**.

CAUTION • Without this procedure, the inputted values are not saved in the microscope. Be sure to execute this procedure.

• If any one of setting values **3**, **4**, **6**, **7**, **9** or **10** (values shown in display Y) is 000.0000, the setting values cannot be saved. An error sound (three short beeps) beeps. Confirm the setting values again.

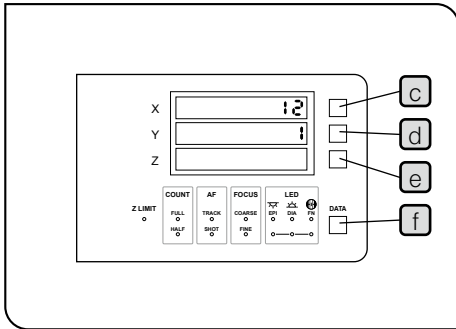

12 Closing the maker setting mode

1. Press the X-RESET button **c** to show "12" in the display X.
2. Press the Y-RESET button **d** or the Z-RESET button **e** to show "1" in the display Y.
3. Press the DATA button **f**.

The maker setting mode is closed and the microscope can be used in the normal status.

CAUTION Without this procedure, the inputted values are not saved in the microscope. Be sure to execute this procedure.

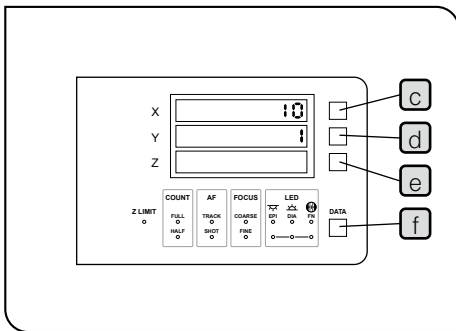

☉ To load the setting values saved in the microscope, perform following procedures.

1. Press the X-RESET button **c** to show "10" in the display X.
2. Press the Y-RESET button **d** or the Z-RESET button **e** to show "1" in the display Y.
3. Press the DATA button **f**.

The setting values are loaded. The setting value is displayed in display Y each time you switch display X.

1 Maker setting mode

Setting values in the maker setting mode must be inputted by Evident.

Do not change the setting values by yourselves.

The work to solve the problems caused by changing the setting values are for compensation.

2 Setting Function List

Setting Items Display X	Setting Items	Setting Values Display Y	Setting Values	Remark
1	X-axis counting direction	0*	Move the stage to left: Positive	Do not change unless necessary. (It is not necessary to set at delivery.)
		1	Move the stage to right: Positive	
2	Standard value of X-axis	000.0001* to 999.9999 mm	Value described in Certificate of Accuracy	
3	Measured value of X-axis	000.0001* to 999.9999 mm	Value described in Certificate of Accuracy	
4	Y-axis counting direction	0*	Move the stage to front: Positive	Do not change unless necessary. (It is not necessary to set at delivery.)
		1	Move the stage to back: Positive	
5	Standard value of Y-axis	000.0001* to 999.9999 mm	Value described in Certificate of Accuracy	
6	Measured value of Y-axis	000.0001* to 999.9999 mm	Value described in Certificate of Accuracy	
7	Z-axis counting direction	0*	Move the focusing unit up: Positive	Do not change unless necessary. (It is not necessary to set at delivery.)
		1	Move the focusing unit down: Positive	
8	Standard value of Z-axis	000.0001* to 999.9999 mm	Value described in Certificate of Accuracy	
9	Measured value of Z-axis	000.0001* to 999.9999 mm	Value described in Certificate of Accuracy	
10	Loading setting values	0	No	
		1	Yes	
11	Saving setting values	0	No	At delivery, after inputting the setting values, be sure to select [1: Save] and exit.
		1	Yes	
12	Exit	0	No	
		1	Yes	

* Initial value

7 MOUNTING AND OPERATING A VIDEO SYSTEM

This microscope can accommodate various types of cameras via the adapters as shown below.

For details, refer to the instructions of the video system to be used.

- ⊙ Use the trinocular observation tube (MM6-ETR) in combination with a video system.
- ⊙ For the digital camera STM7-CU, attach the camera adapter to the microscope so that the connector comes to the right side.
- ⊙ For the microscope digital camera DP22/DP23/DP27/DP28, attach the camera adapter to the microscope so that the connector comes to the rear side.

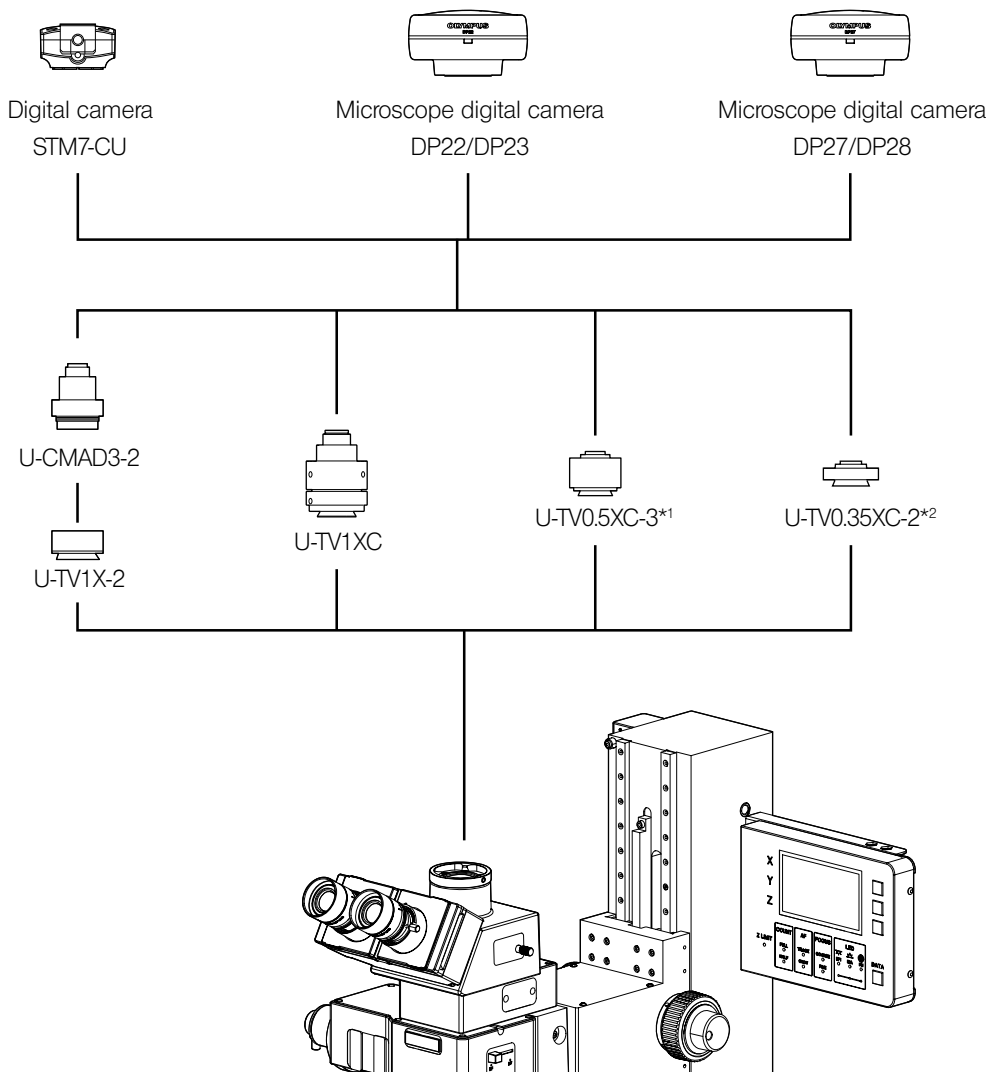

*1 The U-TV0.5XC-3 cannot be used in combination with the microscope digital camera DP28.

*2 The U-TV0.35XC-2 cannot be used in combination with the microscope digital camera DP22/DP23/DP27/DP28.

7-1 Adjusting the tilt of the camera

When the microscope digital camera is attached to the camera adapter, the tilt must be adjusted.

- ⊙ For adjustment, use the measurement objects (metal scales or screwdriver, etc.) which can cover the stage movable range (X-axis) in line.

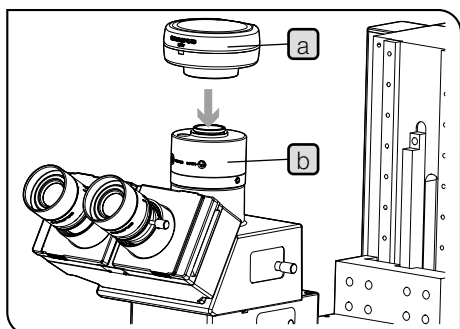

- 1** Attach the digital camera **a** to the camera adapter **b** so that it faces to front.

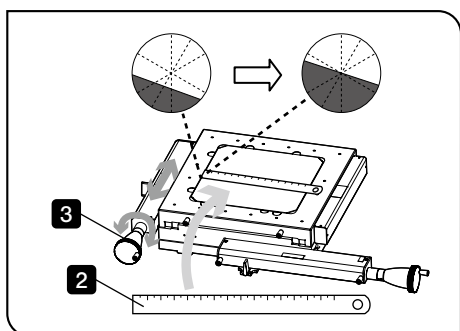

- 2** Place the measurement object on the stage so that it is parallel to the X-axis.

- 3** Look into the eyepiece with cross hairs with the right eye and move the stage so that the left end of the measurement object enters the field of view. Then, adjust the Y-axis so that the edge of the measurement object comes to the center of the cross line.

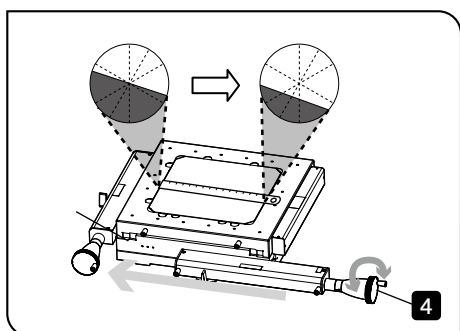

- 4** Move the X-axis to the opposite end.

- ⊙ Since the stage and measurement object are not parallel to each other to some extent, the observed image shifts from the center position as shown in the left picture.

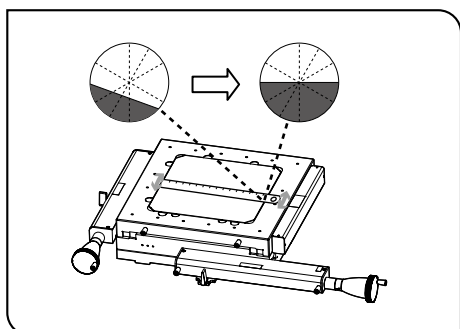

- 5** Change the angle of the measurement object so that the edge of the measurement object comes to the center of the cross line.

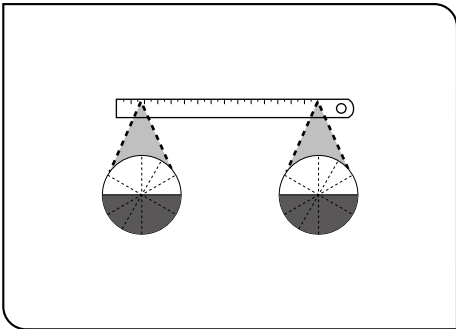

- 6** Move the X-axis to right and left ends.
- 7** Repeat from **3** to **6** until the edge of the measurement object always comes to the center of the cross line.

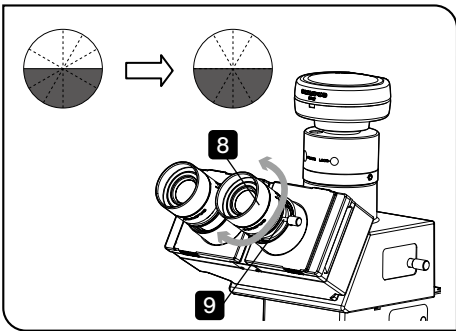

- 8** Rotate the eyepiece sleeve along the edge of the objective.
- 9** Tighten the clamping knob with the tool provided with the frame to fix the eyepiece with cross hairs.

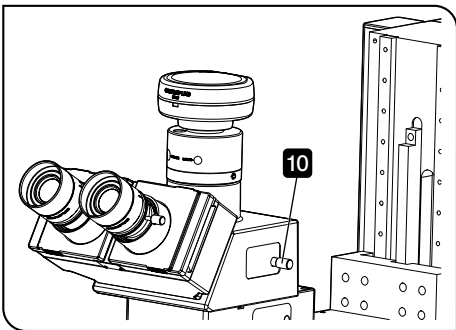

- 10** Slide the light path selector knob to move to the pulled out position. The light path is 100% TV/Photo.

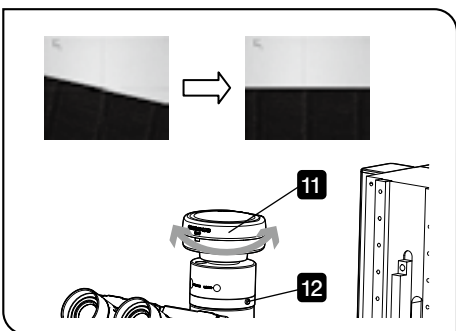

- 11** While observing the live image on the monitor, rotate the camera so that the cross line fits the edge.
- 12** Fix the camera adapter by tightening the clamping screw with the Allen screwdriver provided with the frame.

8 Specifications

■ Frame

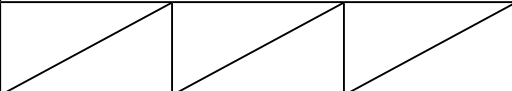
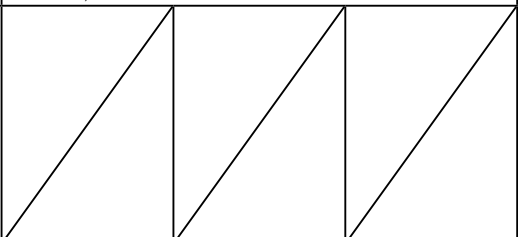
Item	Specifications					
	STM7-SF (Small manual frame)	STM7-MF (Middle manual frame)	STM7-LF (Large manual frame)	STM7-SFA (Small motorized frame)	STM7-MFA (Middle motorized frame)	STM7-LFA (Large motorized frame)
Vertical movement range	175 mm	175 mm	145 mm	175 mm	175 mm	145 mm
Maximum measurable height	120 mm (with measurement objective) ^{*1} , 175 mm (with metallurgical objective) ^{*1}		90 mm (with measurement objective) ^{*2} , 145 mm (with metallurgical objective) ^{*2}	120 mm (with measurement objective) ^{*1} , 175 mm (with metallurgical objective) ^{*1}		90 mm (with measurement objective) ^{*2} , 145 mm (with metallurgical objective) ^{*2}
Z-axis measurement range						
Z-axis measurement resolution	0.1 μm					
Z-axis load weight	10.6 kg (Camera, U-TV1XC, STM7-FN, MM6-ETR, MM6C-RLAS, revolving nosepiece, 5 objectives, filter)			12.8 kg (Camera, U-TV1XC, STM7-AF, MM6-ETR, MM6C-RLAS, revolving nosepiece, 5 objectives)		
	Maximum loading weight			15 kg ^{*3}		
Z-axis drive method	Manual coaxial fine/coarse focusing knobs Reference movement distance per turn of fine focusing knob: 0.2 mm Reference movement distance per turn of coarse focusing knob: 36.7 mm			Motorized		
Hand switch	The operations are available at hand by using 11 buttons, e.g. LED SEL buttons, counter data reset buttons, etc.					
Focus controller						
Focus controller	<ul style="list-style-type: none"> The operations are available at hand by using 17 buttons, e.g. FOCUS button, AF START/STOP button, etc and fine/coarse focusing knob. Coarse movement speed : 8 mm/sec. (max) Movement distance (guide for per turn) of fine/coarse focusing knob can be selected from 4 values: 800 μm, 400 μm, 100 μm, 50 μm 					
Transmitted light illumination	<ul style="list-style-type: none"> Light guide : Green LED for transmitted light illumination Dominant wavelength: Max:550 nm, Min:520 nm Dimensions: $\varnothing 24 \times 81.7$ mm (cable length 1500 mm) Weight: 80 g Average life: Approx. 30000 hours (Ambient temperature 20 °C, light intensity level 50%) 					
Rating	STM7-CB/STM7-CBA: Refer to the instruction manual provided with the control box STM7-CB/STM7-CBA. MM6-ILPS-2: Refer to the instruction manual provided with the power supply unit MM6-ILPS-2.					
Applicable fuses	T5A(H)250V (LITTELFUSE 0215005.MXP)					
Dimensions (between center positions of axes of stage)	427(W)x547(D) x651(H) mm (When combined with STM7-CS100)	606(W)x727(D) x651(H) mm (When combined with STM7-CS200)	805(W)x1025(D) x684(H) mm (When combined with STM7-CS300)	427(W)x547(D) x811(H) mm (When combined with STM7-CS100)	606(W)x727(D) x811(H) mm (When combined with STM7-CS200)	805(W)x1025(D) x844(H) mm (When combined with STM7-CS300)
Frame weight	51.8 kg	77.1 kg	150.5 kg	53.8 kg	78.6 kg	152 kg
Control box weight	Approx. 4.9 kg (STM7-CB) / Approx. 5.4 kg (STM7-CBA)					

*1 When STM7-SF/STM7-SFA is combined with STM7-CS50, subtract 15mm.

*2 The height of the specimen which can be placed at the position more than ± 180 mm farther from the center of measurement (light axis) in the X- or Y-axis direction is 100 mm or less.

*3 If you want to load those other than the standard combinations, contact Evident.

■ Stage

Item	Specifications			
	STM7-CS50	STM7-CS100	STM7-CS200	STM7-CS300
Stage top size	ø140 mm	210x210 mm	360x360 mm	510x510 mm
Stage glass size	ø100 mm	144x144 mm	249x249 mm	349x349 mm
Measuring range	X50mm, Y50 mm	X100 mm, Y100 mm	X200 mm, Y200 mm	X300 mm, Y300 mm
Rotation mechanism	360 °			
Measurement accuracy (L: measuring length)	(3+L/50) μm	(3+2L/100) μm	(3+4L/200) μm	(3+6L/300) μm
Accuracy assurance weight	5 kg	6 kg	10 kg	15 kg
Dimensions (between center positions of axes)	427(W)x377(D)x101.5(H) mm	427(W)x377(D)x87(H) mm	606(W)x522(D)x108(H) mm	805(W)x755(D)x108(H) mm
Weight	18.1 kg	17.7 kg	59.8 kg	111.3 kg

CAUTION • Avoid subjecting the stage to excessively unbalanced load although the applied weight is within the accuracy assurance weight for it may impair the accuracy.

- Do not place the object heavier than the weight described in Certificate of Accuracy on the stage. The product may be damaged.

◎ For the mounting position and size of a tap to clamp a jig on the table, consult your dealer.

■ Rotatable stage

Item	Specifications		
	STM7-RS100	STM7-RS200	STM7-RS300
Attachable stage	STM7-CS100	STM7-CS200	STM7-CS300
Rotation range	360 °		
Stage top size	ø130	ø230	ø330
Metal surface size	ø165 mm	ø270 mm	ø370 mm
Accuracy assurance weight	2 kg	5 kg	7 kg
Dimensions	210(W)x210(D)x30(H) mm	350(W)x300(D)x30(H) mm	440(W)x440(D)x30(H) mm
Weight	2.2 kg	4.4 kg	7.3 kg

■ Reflected Light Arm/Reflected Light Illuminator

Item	Specifications		
	MM6C-VL	MM6C-KMAS	MM6C-RLAS
Optical system	UIS2 (UIS) optics (infinity connection)		
Observation methods	<ul style="list-style-type: none"> Reflected light brightfield 	<ul style="list-style-type: none"> Reflected light brightfield Reflected light DIC Reflected light simplified polarized light 	<ul style="list-style-type: none"> Reflected light brightfield Reflected light DIC Reflected light simplified polarized light
Light source	<ul style="list-style-type: none"> Light guide: White LED for reflected light illumination Color temperature: Max:8000K, Min:5000K Dimensions: $\varnothing 24 \times 81.7$ mm (cable length 1500 mm) Weight: 80 g Average life: Approx. 30000 hours (Ambient temperature 20 °C, light intensity level 50%) 		
Revolving nosepiece		U-5RE-2, U-D6RE, U-5RES-ESD	U-5BDRE, U-D5BDRE, U-D5BDRES-ESD
Applicable objectives	<ul style="list-style-type: none"> MM6-OB series UIS2 (UIS) brightfield metallurgical objectives (used in combination with adapter BD-M-AD) 	<ul style="list-style-type: none"> UIS2 (UIS) brightfield metallurgical objectives Measurement objectives (used in combination with adapter to mount measuring objectives STM7-MMOBAD) 	<ul style="list-style-type: none"> UIS2 (UIS) brightfield metallurgical objectives Measurement objectives (used in combination with adapter to mount measuring objectives STM7-MMOBAD)
Dimensions	119(W) \times 148(D) \times 95(H) mm	241(W) \times 148(D) \times 128.5(H) mm	261(W) \times 158(D) \times 128.5(H) mm
Weight	Approx. 2.6 kg	Approx. 2.6 kg	Approx. 3.1 kg

■ Observation tube

Item	Specifications		
	MM6-EMO	MM6-ETR	U-TLU
Image orientation	Erect image		
Eyepiece tilting angle	Fixed at 30°		
Interpupillary distance adjustment range	56 to 76 mm		
Light path selection	2 options, binocular 100% or photo 100%		
Applicable objectives	<ul style="list-style-type: none"> MM6-OCC10X (with cross hairs & helicoids, power 10X, field number 22) 	<ul style="list-style-type: none"> MM6-OCC10X (with cross hairs & helicoids, power 10X, field number 22) MM6-OC10X (with helicoids, power 10X, field number 22) 	
Dimensions	120(W) \times 188(D) \times 112(H) mm	160(W) \times 143(D) \times 104(H) mm	$\varnothing 60 \times 64$ mm
Weight	1.5 kg	3 kg	0.35 kg

■ Objectives (MM6-OB Series)

Item	Specifications			
	MM6-OB1X	MM6-OB3X-2	MM6-OB5X	MM6-OB10X
Magnification	1X	3X	5X	10X
Working distance (mm)	59.6	76.8	65.4	50.5
Actual field (mm)	22.0	7.3	4.4	2.2
Number of aperture	0.03	0.09	0.13	0.2
Total magnification error	$\pm 0.4\%$			

■ Digital indicator STM7-DI

Item		Specifications
Number of axes		3-axis (X,Y,Z)
Unit		μm/mm/inch/mil
Minimum resolution		0.1 μm
Show/Hide minimum digit		0.1 μm(0.01 mil)/1 μm(0.1 mil)
Display range		±999.9999 mm, ±39.37007 inch
Button functions		Reset counter data of X;Y- and Z-axis Output counter data of X;Y- and Z-axis
Indicator	Z LIMIT	ON: The lower software limit of the focus area is set. OFF: The lower software limit of the focus area is not set.
	COUNT	FULL ON: The counter data of X, Y and Z axes is displayed normally. HALF ON: The counter data of X, Y and Z axes is displayed by 1/2 against the actual movement.
	AF	TRACK blinks: The autofocusing is being stopped in Track mode. TRACK ON: The autofocusing is being operated in Track mode. SHOT blinks: The autofocusing is being stopped in ONE SHOT mode. SHOT ON: The autofocusing is being operated in ONE SHOT mode.
	FOCUS	COARSE ON: The movement distance of the fine/coarse focusing knob of the focus controller STM7-MCZ is large. FINE ON: The movement distance of the fine/coarse focusing knob of the focus controller STM7-MCZ is small.
	EPI (green)	ON: The reflected light illumination is turned ON. OFF: The reflected light illumination is turned OFF.
	EPI (orange)	ON: The reflected light illumination can be controlled. OFF: The reflected light illumination cannot be controlled.
	DIA (green)	ON: The transmitted light illumination is turned ON. OFF: The transmitted light illumination is turned OFF.
	DIA (orange)	ON: The transmitted light illumination can be controlled. OFF: The transmitted light illumination cannot be controlled.
	FN (green)	ON: The illumination for the focus navigator unit is turned ON. OFF: The illumination for the focus navigator unit is turned OFF.
	FN (orange)	ON: The illumination for the focus navigator unit can be controlled. OFF: The illumination for the focus navigator unit cannot be controlled.
Dimensions		226(W)x154(H)x50(D) mm
Weight		1.5 kg

■ Hand switch STM7-HS

Item		Specifications
Button functions		Illumination control Reset counter data of X;Y- and Z-axis Output counter data of X;Y- and Z-axis Memorize/load light intensity value and objective magnification Counting of counter data in-half
Dimensions		147(W)x32(H)x109(D) mm
Weight		0.3 kg

■ Focus controller STM7-MCZ

Item	Specifications
Button functions	Illumination control Reset counter data of X;-Y- and Z-axis Output counter data of X;-Y- and Z-axis Lower software limit setting Autofocus unit STM7-AF control Memorize/load light intensity value and objective magnification Sensitivity of fine/coarse focusing knob Counting of counter data in-half
Focusing unit	FOCUS buttons Fine focusing knob Coarse focusing knob
Dimensions	203(W)x97(H)x110.5(D) mm
Weight	1.9 kg

■ Foot switch STM7-FS

Item	Specifications
Button functions	Output counter data of X;-Y- and Z-axis
Dimensions	115(W)x36(H)x66(D) mm
Weight	0.3 kg

■ Basic software STM7-BSW

Refer to the instruction manuals provided with Basic software / MIA, EFI option software.

■ Digital camera STM7-CU

Item	Specifications	
System	C-mount CCD camera unit	
Image pickup device	Size	1/2-inch CMOS
	Effective pixels	2048x1536 pixels
	Scanning method	Progressive scanning
	Recording area	6.554(H)x4.915(V) mm, diagonal length 8.19 mm
	Resolution	3.1M pixels
Camera mount	C-mount	
Exposure control	Free run mode, trigger mode	
Exposure time	Free run mode: 0.057*2 sec to 1744*3 sec Trigger mode: 0.057*2 sec to 750*3 sec	
Image display speed (Frame rate)	11.2 frames/sec. (maximum)	
Input/output connectors	I/F: USB2.0	
Dimensions	44(W)x30.8(D)x48.6(H) mm	
Weight	41 g	

■ Microscope digital camera DP22/DP23/DP27/DP28

Refer to the instruction manual provided with the microscope digital camera DP22/DP23/DP27/DP28.

■ Adapter to mount measuring objective STM7-MMOBAD

Item	Specifications
Dimensions	ø60x40(H) mm
Weight	0.7 kg

■ Anti vibration plates STM7-VI

Item	Specifications
Dimensions	ø90x24(H) mm
Weight	3.7 kg

■ Focus navigator unit STM7-FN

Item	Specifications
1. Main unit	
Detection method	Adjusts the line of projected the reticle
Applicable objective	LMPLFLN10X-50X LMPLFLN-BD10X-50X MPLFLN10X/MPLFLN-BD10X MPLN10X/MPLN-BD10X LMPLFL10X-50X LMPLFL10X-50XBD UMPLFL10XBD2 MPL10X/MPL10XBD MM6-OB10X
Focusing repeatability	10X: 3.5 μm 20X: 1 μm 50X: 0.7 μm ◎ The experimental value by the mirror sample
Applicable observation methods	Reflected light brightfield observation, Reflected light darkfield observation
Dimensions	105.5(W)x137.5(D)x51(H) mm
Weight	Approx. 1 kg
2. Green LED unit	
LED color	Green
Dominant wavelength	Max: 550nm Min: 520nm
Dimensions	ø24x83 mm Cable length: 1500 mm
Weight	80 g
Average life	Approx. 30000 hours (Ambient temperature 20°C, light intensity level 50%)

■ Control box STM7-CB/STM7-CBA

Refer to the instruction manual provided with the control box STM7-CB/STM7-CBA.

■ Autofocus unit STM7-AF

Refer to the instruction manual provided with the autofocus unit STM7-AF.

■ Power supply unit MM6-ILPS-2



Refer to the instruction manual provided with the power supply unit MM6-ILPS-2.

■ Operating environment

Ambient temperature/ humidity	<table border="0"> <tr> <td>Accuracy guarantee</td> <td>Temperature: 20 °C±1 °C</td> <td>Humidity: 65%±20%</td> </tr> <tr> <td>Operation guarantee</td> <td>Temperature: 10 °C to 35 °C</td> <td>Humidity: 30% to 85%</td> </tr> <tr> <td>Standby condition</td> <td>Temperature: 0 °C to 40 °C</td> <td>Humidity: 20% to 85%</td> </tr> <tr> <td>Storage condition</td> <td>Temperature: -10 °C to 60 °C</td> <td>Humidity: 10% to 90%</td> </tr> </table>	Accuracy guarantee	Temperature: 20 °C±1 °C	Humidity: 65%±20%	Operation guarantee	Temperature: 10 °C to 35 °C	Humidity: 30% to 85%	Standby condition	Temperature: 0 °C to 40 °C	Humidity: 20% to 85%	Storage condition	Temperature: -10 °C to 60 °C	Humidity: 10% to 90%
Accuracy guarantee	Temperature: 20 °C±1 °C	Humidity: 65%±20%											
Operation guarantee	Temperature: 10 °C to 35 °C	Humidity: 30% to 85%											
Standby condition	Temperature: 0 °C to 40 °C	Humidity: 20% to 85%											
Storage condition	Temperature: -10 °C to 60 °C	Humidity: 10% to 90%											
Conditions for safety standards	<ul style="list-style-type: none"> • Indoor use. • Altitude: Max. 2,000 meters • Ambient temperature: 5 to 40 °C (41 to 104 °F) • Maximum relative humidity: 80% for temperatures up to 31 °C (88 °F) (without condensation) In case of over 31 °C (88 °F), the relative humidity is decreased linearly through 70% at 34 °C (93 °F), 60% at 37 °C (99 °F), and to 50% at 40 °C (104 °F). • Supply voltage fluctuations: Not to exceed ±10% of the normal voltage. • Pollution degree: 2 (in accordance with IEC60664-1) • Installation/Overtoltage category: II (in accordance with IEC60664-1) 												

9 Troubleshooting guide

Under certain conditions, performance of the microscope may be adversely affected by factors other than defects. If problems occur, please review the following list and take remedial action as needed. If you cannot solve the problem after checking the entire list, please contact Evident for assistance.

Problem	Cause	Remedy	Page
1. Optical system			
a) The illumination does not light.	The main switch of the control box is not set to ON.	Set the main switch to  (ON).	22
	The LED is blown.	Replace the LED.	-
	Connectors are not connected firmly.	Connect them properly.	69
	The fuses in the control box are blown.	Replace the fuses.	73
	The power supply unit MM6-ILPS-2 is damaged.	Ask Evident.	-
b) The illumination lights but the field is dark or hardly visible.	The light path selector knob of the trinocular tube is set to the  position.	Set it to the  position.	34
c) The field is cut or uniformly dark.	The light path selector knob of the trinocular tube is set to an intermediate position.	Set it correctly.	34
	The revolving nosepiece is not attached correctly.	Push in all the way into the mount dovetail and clamp firmly.	65
	The revolving nosepiece is not set to a click position.	Set to a click position.	-
	The filter is stopped at an intermediate position.	Set it properly.	35
d) Dirt or dust is observed in the field of view	Dust or dirt on the top surface of the stage glass.	Clean them thoroughly.	12
	Dust or dirt on the specimen.		
	Dust or dirt on the objective tip.		
	Dust or dirt on the eyepiece.		
	Dust or dirt on the filter slider, polarizer or slider.		
e) Image is poor. · Image is not sharp. · Contrast is poor. · Details are not clearly visible.	The specified objective and eyepiece are not used.	Use the specified objective and eyepiece.	64,67
	The revolving nosepiece is not attached properly.	Push in all the way into the mount dovetail and clamp firmly.	65
	The objective is not engaged properly in a light path.	Set the revolving nosepiece to a click position.	-
	The objective tip is dirty.	Clean them thoroughly.	12
	The stage glass is dirty.		
	The specimen is dirty.		
	The eyepiece is dirty.		
	Dust or dirt on the filter slider, polarizer or slider.		
f) Half the image is blurred or the image looks flowing.	The revolving nosepiece is not attached properly.	Push in all the way into the mount dovetail and clamp firmly	65
	The objective is not engaged properly in a light path.	Set the revolving nosepiece to a click position.	-
	The specimen is tilted.	Correct the specimen tilting to make it horizontal.	-

Problem	Cause	Remedy	Page
2. Control box			
a) The illumination turns on and off spontaneously.	Connectors are not connected firmly.	Connect them properly.	69
b) The illumination often blows.	The LED is not as specified.	Use the specified LED.	
c) The brightness cannot be changed even though the brightness is changed with the hand switch, the focus controller or the power supply unit.	The LED is not installed.	Attach a LED.	
	The LED is blown.	Replace the LED.	
	The control box connector is unplugged.	Connect it properly.	69
3. Fine/coarse focusing knob (Manual frame only)			
a) The Z-axis counter data varies little by little. (Image is blurred)	The focusing unit is lowering by its own weight.	Adjust the coarse focusing knob rotation tension to prevent spontaneous lowering.	24
4. Hand switch/Focus controller			
a) The buttons do not work.	Connection cables are unplugged.	Connect the connectors properly.	69
5. Focus controller			
a) The AF START/STOP, AF MODE and AF OB buttons do not work.	The AF unit is not connected.	The AF START/STOP, AF MODE and AF OB buttons are invalid unless the AF unit is connected.	-
	The connection cable is unplugged.	Connect it properly.	69
b) Focusing stops before correct focusing is obtained.	The setting position of the lower software limit is wrong.	Set it correctly again.	32
c) The objective collides with the specimen even though the lower software limit is set.	The setting position of the lower software limit is wrong.	Set it correctly again.	32
d) The action of the fine/coarse focusing knob is too large or small.	The fine/coarse focusing setting is wrong.	Set the Z-axis movement amount to facilitate operation.	28
e) The Z-axis will not move when the button is pressed.	The emergency stop switch on the control box for motorized is pressed.	Rotate the emergency stop switch in the resetting direction (clockwise), and then rotate the fine/coarse focusing knob of the focus controller STM7-MCZ to move the focusing unit to the safe position. Then, set the main switch of the control box for motorized to "●" (OFF), and set the main switch of the control box for motorized to "↑" (ON) again. When the error sound (five short beeps) is heard, move the focusing unit by 50 μm or more and set the main switch of the control box for motorized to "●" (OFF). Then, set the main switch to "↑" (ON) to cancel the error.	22
6. Observation Tube			
a) The visual fields of the two eyes do not meet, causing eye fatigue.	The interpupillary distance is not adjusted correctly.	Adjust it correctly.	33
	The diopter between the two eyes is not adjusted correctly.	Adjust it correctly.	33

Problem	Cause	Remedy	Page
7. Stage			
a) The observation image moves too much when the stage is touched with hand.	A stage clutch lever is released.	Set both clutches securely.	36
	The modules (stage, etc.) are loosened.	Secure the modules firmly.	-
	The microscope is used in an environment with frequent vibration.	Install the microscope in an environment with less vibration.	-
	The microscope is installed on a table with a thin top board.	Install the microscope on a table with a thick top board.	-
b) The X- and/or Y-feed knobs run idle.	A clutch lever is released.	Set the clutches securely.	36
	A clutch is set to an intermediate position.	Release the clutches and retry setting them securely.	36
c) The stage moves spontaneously when a clutch is released.	The horizontality of the base is not adjusted.	The horizontality of the base is not adjusted.	62
		Adjust the horizontality of the desk where the frame is installed.	-
d) The specimen is moved when a knob is turned quickly.	The specimen is moved at the stage movement speed	Fix the specimen.	-
8. Display (Digital indicator, Basic software and Excel transfer tool)			
a) The display shows nothing.	The main switch of the control box is not set to ON.	Set the main switch to ⬆ (ON).	22
	The fuses in the control box are blown.	Replace the fuses.	73
	Cables are not connected completely.	Connect them properly.	69
b) The Excel transfer tool does not start.	Cables are not connected completely.	Connect them properly.	69
	The COM port is used for other functions.	Check the settings of the COM port again.	-
c) The measured values are too different from what is expected.	The "µm/mm/inch/mil" setting is erroneous.	Set it properly.	49
d) The values cannot be transferred to the controller.	Microsoft® Office is not started.	Start Microsoft® Office.	-
	Using an incompatible Microsoft® Office version.	For compatibility, refer to the instruction manuals provided with Basic software / MIA,EFI option software.	
e) Only the X- and Y-axis values are output to the external processing devices.	The data output is set to the X-/Y-axes only.	Set it properly.	49
f) Display shows "013F0500".	The setting value is not inputted.	Input the setting value.	74
g) Display shows "013F1503".	The hand switch STM7-HS is not connected to the control box for manual STM7-CB.	Connect the cable.	69
h) Display shows "013F1504".	The focus controller STM7-MCZ is not connected to the control box for motorized STM7-CBA.	Connect the cable.	69
i) Display shows "013F1505".	The Z-scale cable is disconnected.	Connect the cable.	69
j) Display shows "013F1506".	The emergency stop switch is pressed.	Reset the emergency stop switch.	22
k) Display shows "013F1507".	Since the emergency stop switch was pressed before exiting last time, the confirmation of operations when the microscope starts is interrupted.	Operate either the FOCUS button ▲▼ of the focus controller, the AF START/STOP button or the fine/coarse focusing knob.	22

Problem	Cause	Remedy	Page
l) Display shows "013F1511".	The X scale cable is disconnected or the abnormality is detected in the scale.	Connect the X-scale cable properly and press the X-RESET button to cancel the error. The counter data displayed after the error is canceled is not a correct value. Perform the measurement again. If you cannot solve the problem, contact Evident for assistance.	69
m) Display shows "013F1521".	The Y scale cable is disconnected or the abnormality is detected in the scale.	Connect the Y-scale cable properly and press the Y-RESET button to cancel the error. The counter data displayed after the error is canceled is not a correct value. Perform the measurement again. If you cannot solve the problem, contact Evident for assistance.	69
n) Display shows "013F1531".	The Z scale cable is disconnected or the abnormality is detected in the scale.	Connect the Z-scale cable properly and press the Z-RESET button to cancel the error. The counter data displayed after the error is canceled is not a correct value. Perform the measurement again. If you cannot solve the problem, contact Evident for assistance.	69
o) Display shows "013F0600".	The printer is in error. (out of paper, the cover is open, etc.)	Clear the printer's error status.	-
9. Autofocus unit			
a) Autofocusing cannot be obtained. (Desired point cannot be focused.)	Specimen has low reflectance (3% or less).	Focus on the specimen manually.	28
	Specimen is not suitable for AF. <ul style="list-style-type: none"> Irregular specimen surface Thin, transparent structure 	Focus on the specimen manually. Or perform autofocusing on a less irregular surface.	28,39
	Objective other than specified is in use.	Use objectives specified as autofocusing compatible. (Refer to the instruction manual provided with the autofocus unit.)	-
	Dirt or stain on specimen.	Remove dirt, stain, etc.	12
b) Though autofocusing has been completed normally, specimen is not focused when looked at visually.	Autofocusing position adjustment is erroneous.	Adjust focusing position.	39
c) Autofocusing cannot be switched START/STOP.	The connection cable may be unplugged.	Check that the cable is connected properly.	69

■ Proper selection of the power supply cord

If no power supply cord is provided, please select the proper power supply cord for the equipment by referring to “Specifications” and “Certified Cord” below:

Caution : In case you use a non-approved power supply cord for Evident products, Evident can no longer warrant the electrical safety of the equipment.

Specifications

Voltage rating	125 V AC (for 100-120 V AC area) or, 250 V AC (for 220-240 V AC area)
Current rating	6 A minimum
Temperature rating	60 °C minimum
Length	3.05 m maximum
Fittings configuration	Grounding type attachment plug cap. Opposite terminates in molded-on IEC configuration appliance coupling.

Table 1 Certified cord

A power supply cord should be certified by one of the agencies listed in Table 1 , or comprised of cordage marked with an agency marking per Table 1 or marked per Table 2. The fittings are to be marked with at least one of the agencies listed in Table 1. In case you are unable to buy locally the power supply cord which is approved by one of the agencies mentioned in Table 1, please use replacements approved by any other equivalent and authorized agencies in your country.



















Country	Agency	Certification mark	Country	Agency	Certification mark
Argentina	IRAM		Italy	IMQ	
Australia	SAA		Japan	JET	
Austria	ÖVE		Netherlands	KEMA	
Belgium	CEBEC		Norway	NEMKO	
Canada	CSA		Spain	AEE	
Denmark	DEMKO		Sweden	SEMKO	
Finland	FEI		Switzerland	SEV	
France	UTE		United Kingdom	ASTA BSI	
Germany	VDE		USA	UL	
Ireland	NSAI				

Table 2 HAR flexible cord

Approval organizations and cordage harmonization marking methods

Approval organization	Printed or embossed harmonization marking (May be located on jacket or insulation of internal wiring)		Alternative marking utilizing black-red-yellow thread (Length of color section in mm)		
			Black	Red	Yellow
Comite Electrotechnique Belge (CEBEC)	CEBEC	⟨HAR⟩	10	30	10
Verband Deutscher Elektrotechniker (VDE) e.V. Prüfstelle	⟨VDE⟩	⟨HAR⟩	30	10	10
Union Technique de l'Electricite' (UTE)	USE	⟨HAR⟩	30	10	30
Instituto Italiano del Marchio di Qualita' (IMQ)	IEMMEQU	⟨HAR⟩	10	30	50
British Approvals Service for Electric Cables (BASEC)	BASEC	⟨HAR⟩	10	10	30
N.V. KEMA	KEMA-KEUR	⟨HAR⟩	10	30	30
SEMKO AB Svenska Elektriska Materielkontrollanstalter	SEMKO	⟨HAR⟩	10	10	50
Österreichischer Verband für Elektrotechnik (ÖVE)	⟨ÖVE⟩	⟨HAR⟩	30	10	50
Danmarks Elektriske Materialkontroll (DEMKO)	⟨DEMKO⟩	⟨HAR⟩	30	10	30
National Standards Authority of Ireland (NSAI)	⟨NSAI⟩	⟨HAR⟩	30	30	50
Norges Elektriske Materielkontroll (NEMKO)	NEMKO	⟨HAR⟩	10	10	70
Asociacion Electrotecnica Y Electronica Espanola (AEE)	⟨UNED⟩	⟨HAR⟩	30	10	70
Hellenic Organization for Standardization (ELOT)	ELOT	⟨HAR⟩	30	30	70
Instituto Portages da Qualidade (IPQ)	np	⟨HAR⟩	10	10	90
Schweizerischer Elektro Technischer Verein (SEV)	SEV	⟨HAR⟩	10	30	90
Elektriska Inspektoratet	SETI	⟨HAR⟩	10	30	90

Underwriters Laboratories Inc. (UL)
Canadian Standards Association (CSA)

SV, SVT, SJ or SJT, 3 X 18AWG
SV, SVT, SJ or SJT, 3 X 18AWG

Manufactured by

Evident Corporation

6666 Inatomi, Tatsuno-machi, Kamiina-gun, Nagano 399-0495, Japan

Distributed by

Evident Europe GmbH

Caffamacherreihe 8-10, 20355 Hamburg, Germany

Evident Europe GmbH – UK Branch

Part 2nd Floor Part A, Endeavour House, Coopers End Road, Stansted CM24 1AL, UK

Evident Scientific, Inc.

48 Woerd Ave, Waltham, MA 02453, USA

Evident Scientific Singapore PTE. LTD.

#04-04/05, 25 Ubi Rd 4, UBIX Singapore 408621

Evident Australia PTY LTD

Level 4, 97 Waterloo Road Macquarie Park NSW 2113, Australia

Life science solutions

Service Center



<https://www.olympus-lifescience.com/support/service/>

Official website



<https://www.olympus-lifescience.com>

Industrial solutions

Service Center



<https://www.olympus-ims.com/service-and-support/service-centers/>

Official website



<https://www.olympus-ims.com>