

Optical Measuring Instrument

USPM-RUIII series
USPM3-100、USPM3-200
Hardware Operation Manual

OLYMPUS®

Before you get started

Thank you for purchasing Olympus Lens Spectral Reflectivity Measurement USPM3-100/USPM3-200. Before you start using it, please be sure to read this operation manual carefully, and then, store it in a readily accessible safe place, so that it can be referred to at any time you need it. Our warranty card is attached to the back of the manual. Complete the required entries, and then store the card in a safe place.

PREFACE

- How to carry
For how to carry this product, refer to 2.2 How to carry and install the product.
- How to clean
For how to clean this product, refer to 2.3 How to clean.
- Usage environment
Use this product in an environment that conforms to the specification.
For the specification of usage environments, refer to 9. SPECIFICATIONS.
- About the lamp house
Though heavily dependent on the usage conditions (ambient temperature and humidity, supply voltage, period of lighting, etc.), the useful life of the lighting device (lamp house) * assumes either short one of for approximately three years (In the case of the use of approximately eight hours a day) or approximately 15,000 hours .
*The above statement does not guarantee freedom from failures or repair at no charge during the service life.
* Depending on the usage conditions, there is a possibility of aging degradation in a shorter period.
Inspect the lamp house according to **Appendix: Checklist for inspection of the lighting device (lamp house)** until the lamp house reaches the end of its useful life. Should any unexpected incident occur (e.g., smoke) during use, turn off the power immediately and contact the sales representative where you purchased the unit or our sales department. Regular inspection is recommended, in order to achieve safe use and reduce downtime.
- About the personal computer (hereinafter "computer")
We (Olympus) will take no responsibility for any and all damage arising out of the use or malfunction of the unit, including, but not limited to, any damage to the data stored in your personal computer(s). Please make a backup copy of your computer system and keep it in a safe place. (Olympus does not provide any backup support.)

We assure the quality of the unit when it is shipped from our factory. No malfunction or disability due to any change in the environment settings of the computer by you (e.g., any change in the BIOS) or installation of any other applications are covered by the quality assurance of Olympus.

When there is only a small amount of free space in the computer's hard disk drive this may make the data processing take longer or even cause errors. Delete unneeded data files regularly. For how to delete data files, refer to the operating system manual.

NEVER delete or rename any folders already included on the hard disk drive of the computer in the configuration at the set up. Otherwise, the software may become no longer usable.

SAFETY PRECAUTIONS

About safety

If this product is used in a way that is not described in this document, safety is not guaranteed, in addition to the risk of failure. Always adhere to the instructions given here.

Description of Symbols and Terms Used in This Instruction Manual

The following symbols and terms are introduced in connection with possibly hazardous operations and practices according to the importance of the involved hazards. Pay utmost attention to these symbols and terms to ensure the safe use of the device.



Failure to follow the instructions associated with this symbol could cause an accident, such as fire, electric shock, etc., which could result in serious injury to the user or death.



Failure to follow the instructions associated with this symbol could result in an accident, such as electric shock which could cause injury to the eyes or body of the user, or result in damage to the

■ Symbols denoting prohibition (prohibited actions)



Prohibited



Disassembly
prohibited

■ Symbols denoting obligation (mandatory actions)



Mandatory



Unplugged



Grounded

■ Symbols denoting caution



Caution



Caution against
ignition





Caution against
electric shock

Symbols relating to safety

Lens Spectral Reflectivity Measurement USPM3-100/USPM3-200 contains the following symbols.

Handle the product safely, keeping in mind the significance of these marks.

Symbols	Description
	Avoid touching the surface since it is hot. There is a risk of burns.
	Indicates an unspecified, common danger. Follow the instruction in the operation manual or that shown with the mark.
	An inter-switching push button turns on/off the main switch.

Symbols on the package

The package has the following symbols:



Indicates this side up.



Indicates that the box should be protected from rain.



Indicates that the items inside are fragile and that the package should be handled with care.



Indicates the compatibility with China RoHS.



If the following cautions are not observed, there may be a possibility of fire, electric shock, etc., which could result in serious injury to the user or death.



Prohibited

- Do not install the device in a location that is frequently exposed to dust, moisture, oily fumes, or steam.

If the device is installed in any of aforementioned environments, fire or electric shock hazards may result. To install the device, avoid a location exposed to direct sunlight, location at an unusually high temperature, such as near a space heater, heating unit, etc., or at a very low temperature, or a location with high humidity, heavy dirt or dust.



Prohibited

- Do not introduce water or a foreign object into the device.

Introducing water or a foreign object into the device will result in a fire or electric shock hazard. If water or a foreign object is found to have been accidentally introduced into the device, immediately switch off the device. Unplug the power cord. Then contact the vendor from whom the device was purchased.



Disassembly
prohibited

- Do not modify or disassemble the part.

Unauthorized disassembling or modifying of the system might cause fire, electric shock, or injury. If any abnormality occurs as a result of unauthorized modification of the system, such as the failure of the piezo element, inactivation of the computer display, inactivation of the computer, blown fuse, development of unusual odor and sounds, etc., power off the system instantly. Remove the power cord from the wall outlet. Contact our sales department for repair. Troubleshooting by an unauthorized person, which is very dangerous, is strictly prohibited.



Prohibited

- Do not block the ventilation hole for heat radiation of the light source!

The light source (U-LH100L-3) becomes very hot while the lamp is on. Be careful not to block the ventilation hole for heat radiation. If the lamp is turned on with the ventilation hole blocked, it may lead to fire.



Mandatory

- Set up the main body 10cm or more apart from walls!

The light source (U-LH100L-3) becomes very hot while the lamp is on. Set it up with the main body and the wall 10cm or more apart. It may lead to fire.



Prohibited

- Do not touch on the light source. Moreover, do not put the thing.
The light source (U-LH100L-3) becomes very hot while the lamp is on. Do not touch on the light source. Moreover, do not put the thing. It may lead to the burn and a fire.



Prohibited

- Do not cover with the vinyl cover etc. until the light source gets cold.
The light source (U-LH100L-3) becomes very hot while the lamp is on. Do not cover with the vinyl cover etc. until the light source gets cold. It may lead to a fire.



Prohibited

- Do not handle the device with wet hands.
If the user handles the device with wet hands, or plugs or unplugs the power cord using wet hands, severe electric shock could result.



Mandatory

- Operate the device with the specified power!
Input voltage of the Control Box is configured to 100–120 V or 220–240 V, depending on the shipment destination. There is a nameplate indicating the voltage setting on the back surface. Use this product within the voltage range. Otherwise there is a risk of damage or fire. Make sure to contact our service department when you move it into a place having a different voltage range.



Grounded

- Ground the unit securely!
Connect the earth terminal of a three-terminal outlet to the ground for safety. Imperfect grounding may cause electric shocks. Without grounding, the intended electrical safety is not achieved.



Mandatory

- Always use the supplied cables.
Always use supplied cables. Using any cables other than those supplied may cause malfunctions due to internal and/or external noise.



Mandatory

■ Always use the supplied power cord.

Employing any other cables than those supplied may cause failures due to internal and/or external noises.

The supplied cables are not usable with any other devices.

When no power cord is attached to the product, refer to the “Precautions for proper use of the power cord” to choose a proper power code for the unit.



Caution

■ Replacement of fuses

Before replacing a fuse, turn off the power and unplug the power cord so as to avoid electric shocks.

Rating of the fuse: 250 V AC, 3.15 A

Type of the fuse: Time lag , High breaking capacity type

Size of the fuse: $\varnothing 5.2 \text{ mm} \times 20 \text{ mm}$



Caution

■ Replacement of the lamp

Use the specified lamp for replacement. Otherwise there is a risk of damage or fire.

Compatible lamp: 12 V 100 W (7023 from PHILIPS)



CAUTION

Failure to conform to the following cautions may cause injury or physical damage to peripheral devices.



Prohibited

■ Do not install the device in an unstable location.

If the device is installed on an unstable platform, an inclined floor, or a floor lacking sufficient rigidity, the device could fall or collapse, which might cause bodily injury to the user or others in the area. Prior to installation, thoroughly check the rigidity and flatness of the place where the device is to be installed.



Prohibited

■ Do not change the lamp outright after turning it off!

To change the lamp because it was burnt out, or for any other reason, wait till after it has cooled down enough, because it is very hot immediately after switched off.



Caution

- Exert good caution in focusing!
When bringing the reflection sample surface into focus, use good caution not to allow the objective to inadvertently hit the sample surface.



Prohibited

- Measure the sample at a normal temperature
If the sample temperature is higher than normal, the sample may transform or give damaged to the stage..



Caution

- FCC Warning
If the user changes or modifies a device without first receiving permission from the entity responsible for ensuring the device complies with FCC rules, the user forfeits the right to operate the device.

Position of the warning label



Caution

■ Warning labels

The lamp house, which becomes hot, has a warning label (back of the unit). Make sure to adhere to the instructions. If the label is missing, or it gets dirty or starts to peel, contact your supplier for a replacement.



Warning label

Indicates precautions about replacement of lamps.

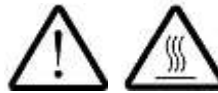

Caution

Confirm that a lamp turns off the light!

Please confirm that a lamp turns off the light by all means before excluding a lamp house

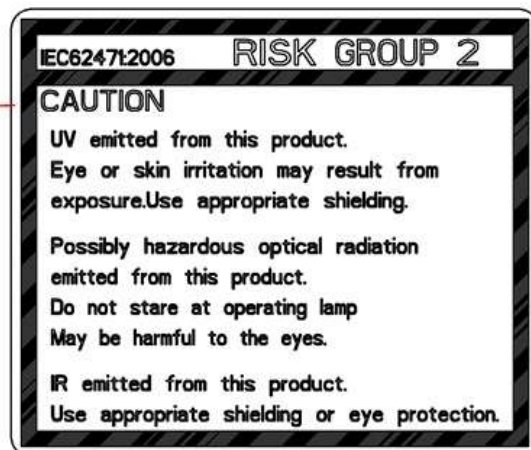
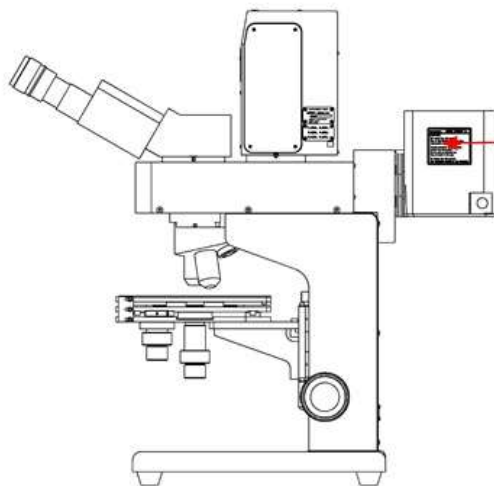

This product corresponds to RISK GROUP2 in a UV range (200-400nm) and a blue light range (300-700nm) based on IEC62471-2.

In addition, this product corresponds to RISK GROUP1 in the IR range (780-3000nm).

TABLE OF CONTENTS

1. PURPOSES AND FEATURES	11
2. CARRYING AND INSTALLATION	12
3. NAMES AND FUNCTIONS OF COMPONENT PARTS	15
4. ASSEMBLING AND CABLING	22
5. MEASURING METHOD.....	25
6. PRINCIPLE OF MEASUREMENT	28
7. REPLACEMENT OF FUSES.....	29
8. REPLACEMENT OF LAMP	30
9. SPECIFICATIONS	31
10. LAWS AND REGULATIONS	33
11. QUALITY ASSURANCE (WARRANTY SHEET).....	35
APPENDIX	37

○ Precautions for proper use of the power cord

1. PURPOSES AND FEATURES



The product is intended to measure spectral characteristics, including reflectance. Do not use for any other purpose.

1.1 Intended uses of this product

Lens Spectral Reflectivity Measurement USPM3-100/USPM3-200 is intended to measure the reflectance of a coated plane. Through easy operations, the reflectance of a subject is calculated in comparison to that of the reference sample.

1.2 Features

This device has the following useful features:

- Short measurement time
Use of high-speed spectrometry based on a flat field grating and line sensor enables the measurement to be finished within a short time.
- Cutout of rear surface reflection noise
The device employs zonal illumination to cut out rear surface reflection noise. Therefore, it allows to accurately measure the reflectance of the front surface only, without the need for antireflection treatment on the rear surface or any other countermeasure.
- Reflectance measurement of minute area
The objective forms a spot of approximately 60 [μm] (when the 10x objective is employed) on the surface under measurement. This allows to measure also lens curvatures and coating unevenness.
- Flexible comparison measurement
Since the reflectances of different comparison measurement masters can be set up as reference values, the device can be applied to comparison measurements with flexibility.

2. CARRYING AND INSTALLATION



Input voltage is configured to 100–120 V or 220–240 V, depending on the shipment destination. There is a label indicating the voltage setting on the back surface. Use this product within the voltage range. Otherwise there is a risk of damage or fire. Make sure to contact our service department when you move it into a place having a different voltage range.

2.1. Conditions of installation

- (1) Avoid any place that is exposed to direct sunlight, extremely hot (near a heater or a thermal appliance) or cold, or any humid, dirty or dusty place.
- (2) Install it on a flat, stable and solid bench.
- (3) Avoid any place exposed to frequent vibration.
- (4) Before moving the product to a location having different voltage, it is necessary to change the voltage configuration of the product. Contact our service department for assistance.

2.2. How to carry and install the product

Keep the following cautions in mind when installing the product:



Always firmly hold the base when carrying or installing the product. Otherwise there is a risk of failure.

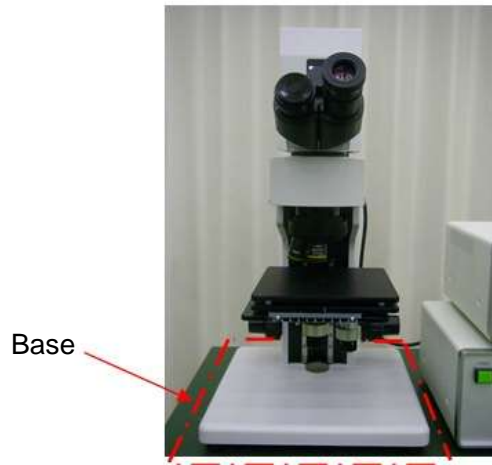

Always use two or more persons to unpack, install or carry the device, which weighs about 20 kg. Handling the device alone may cause injury.



Do not allow any impact to occur to the device when unpacking or installing it. Damage to optical parts or undesired effects to the sample adjustment feature of the product may result, causing failure or incorrectness.



Avoid installing the product in an unstable place or any place with strong vibrations. There is a risk of the unit overturning or falling, or injury. Take the usage conditions into consideration when installing it.



Do not place equipment so that it is difficult to pull out power supply cord from rear side receptacle of Control Box and Light Source Power Supply

- (1) Remove the main unit, cables and accessories from the shipping box.
- (2) Check whether all of the items listed in [Packaged Items] are in place.
- (3) Remove the packing materials and check whether there is any visible damage to the contents.
- (4) Set up the main unit, the control box, the light source power supply and computer into a place that satisfies the installation conditions.

2.3. How to clean

- (1) Use a commercial air blaster to blow dust off the lens and then wipe it softly with a sheet of lens cleaning tissue (or washed gauze).

Wipe off any fingerprints or oils with a sheet of lens cleaning tissue dampened with a little absolute alcohol.



Absolute alcohol is highly flammable. Never place the device near an open flame when using absolute alcohol, and do not handle any electrical device switches that may cause ignition. In addition, make sure there is sufficient ventilation in the room. Before conducting maintenance on the lamp house, wait until it is cool enough to

- (2) Avoid using any organic solvents in the cleaning of any parts other than the lens. Wipe off heavy dirt, if any, with a soft cloth slightly dampened with diluted neutral detergent.

3. NAMES AND FUNCTIONS OF COMPONENT PARTS

3.1. Names of Component Parts

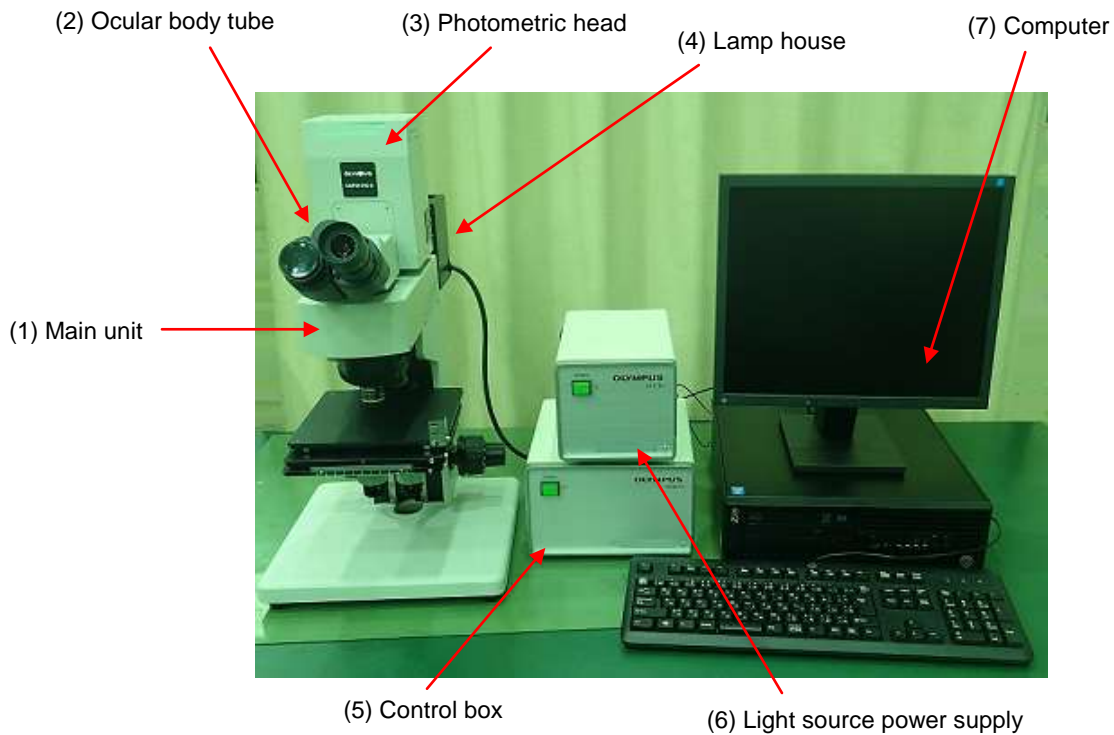

Figure 1-1. The complete system

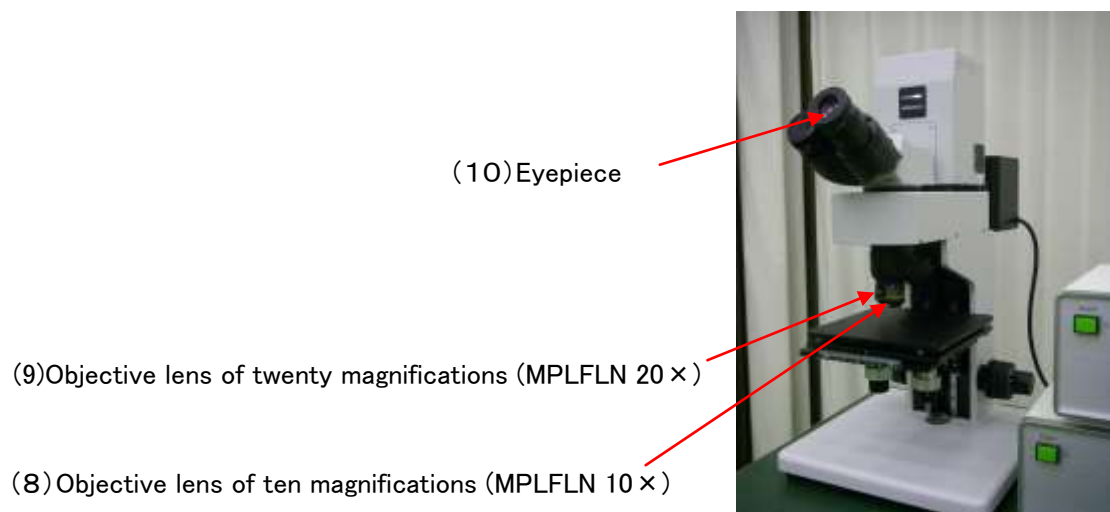

Figure 1-2. Optical component

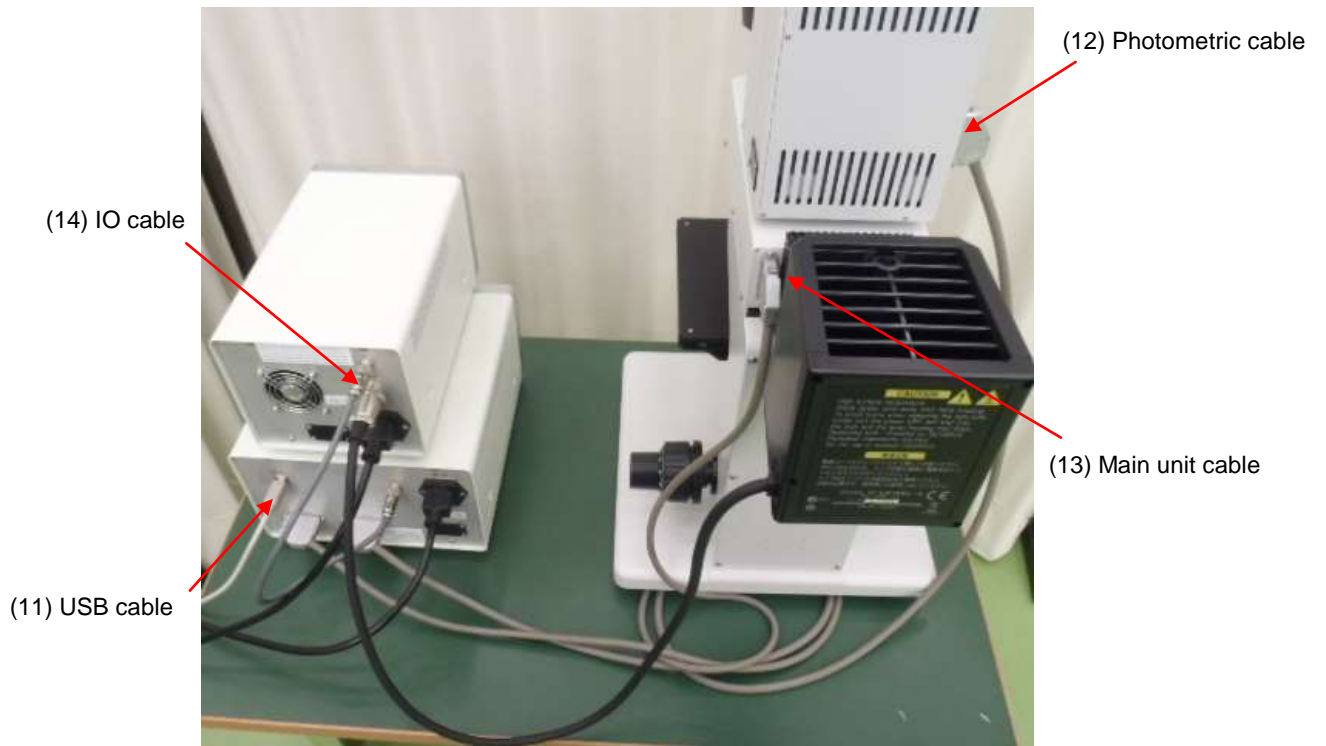

Figure 1-3. Cables supplied

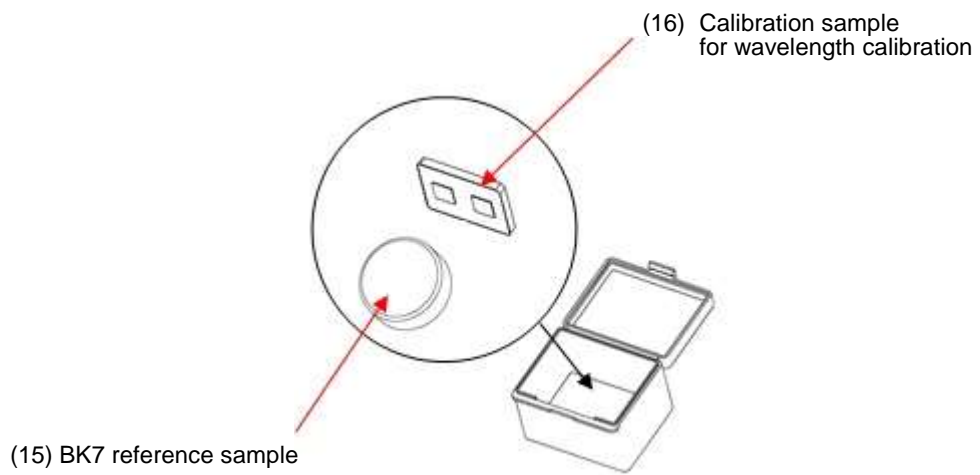

Figure 1-4. Samples supplied

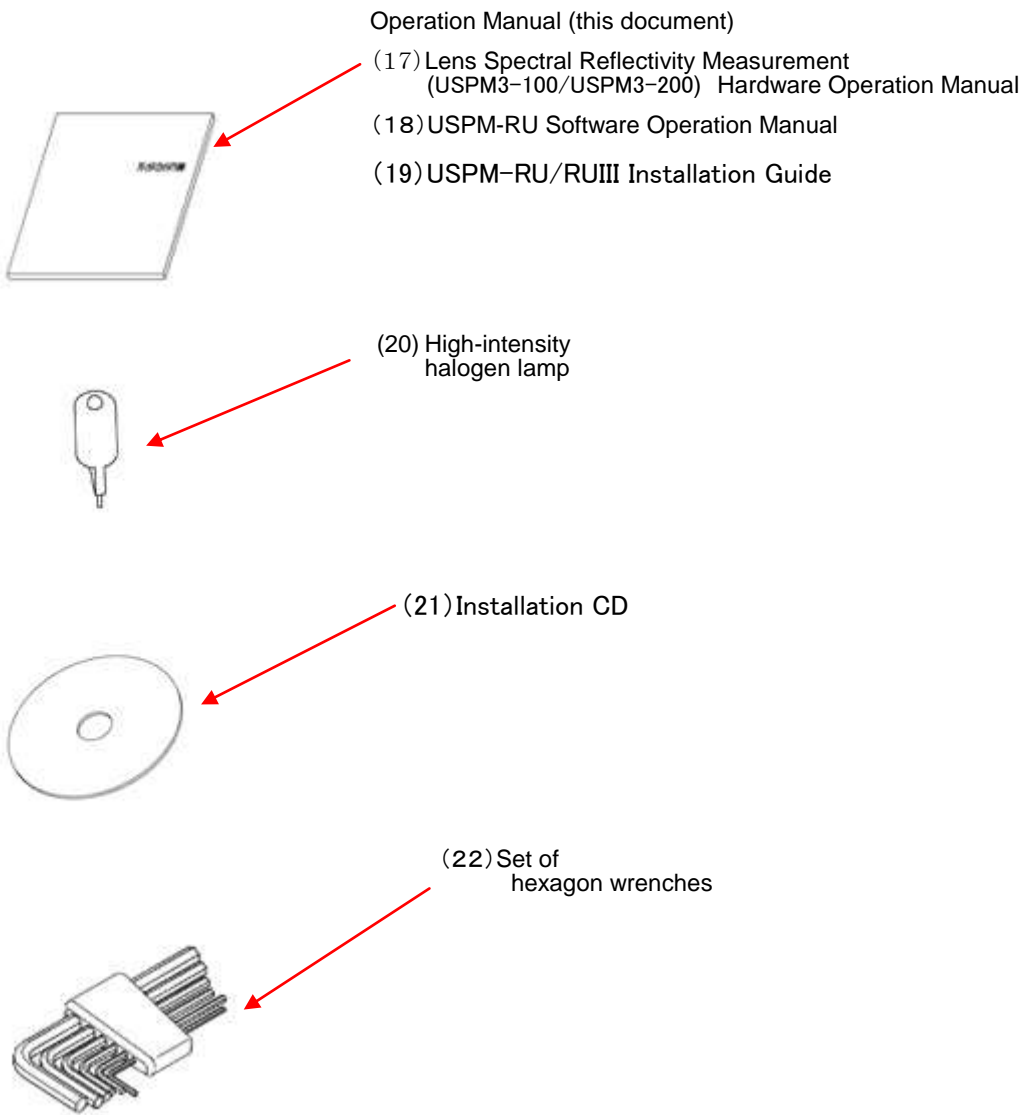

Figure 1-5. Accessories in box

3.2. Features of each component

The device

- (1) Main unit
Contains the spectrometric optical system.
- (2) The ocular body tube (U-BI30-2)
Used for observing the reflected light from the subject.
- (3) Photometric head (USPM-380)
Receives and conducts spectrometry of light from the subject.
- (4) Lamp house (U-LH100L-3)
Accommodates a halogen lamp.
- (5) Control box (UCB-01)
Captures data from the photometric head and transmits it to the computer.
- (6) Light source power supply (ULP-01)
Supplies the lamp house with 12 V (DC 12 V output ---) power.
- (7) Computer
Processes the data sent from the control box and displays the measurement results.

Optical components

- (8) Objective lens of ten magnifications (MPLFLN 10×)
Irradiates the subject with convergent light. This lens allows you to measure a spot of about 60 μm .
- (9) Objective lens of twenty magnifications (MPLFLN 20×)
Irradiates the subject with convergent light. This lens allows you to measure a spot of about 30 μm .
- (10) Eyepiece (MICRO SWH 10×)
Combines with the ocular body tube to observe light reflected from the subject.

Cables

- (11) USB cable
Connects the control box with the computer.
- (12) Photometric cable
Connects the control box with the photometric head.
- (13) Main unit cable
Connects the control box with the main unit.
- (14) IO cable
Connects the control box with the light source power supply.

Samples

- (15) BK7 reference sample (reference)
Used for setting the reference values.
- (16) Calibration sample for wavelength calibration (CALIB sample)
Used for checking and calibrating the wavelength direction.

Accessories

- (17) Lens Spectral Reflectivity Measurement (USPM3-100/USPM3-200) Hardware Operation Manual
The manual describes how to install the product, conduct measurements with it, and perform maintenance. Consult this manual when operating the product.
- (18) USPM-RU Software Operation Manual
The software manual: Consult this manual when using the software.
- (19) USPM-RU/RUIII Installation Guide
The manual describes how to install the software. Consult this manual when reinstalling the software.
- (20) High-intensity halogen lamp (with ten spares)
Spare halogen lamps.
- (21) Software CD
Installation CD. Use to reinstall the software.
- (22) Set of hexagon wrenches (1.5 mm/2 mm/2.5 mm/3 mm/4 mm/5 mm)
Use these tools to install the photometric head onto the main unit.

3.3. Expendable parts

- High-intensity halogen lamps (7023 from PHILIPS, Average life: 50H*)
 - * Average life is the time when half of the test samples are burned out.
In short, the time at which the survival rate reaches 50%.

3.4. Names of the parts of the control box (UCB-01)

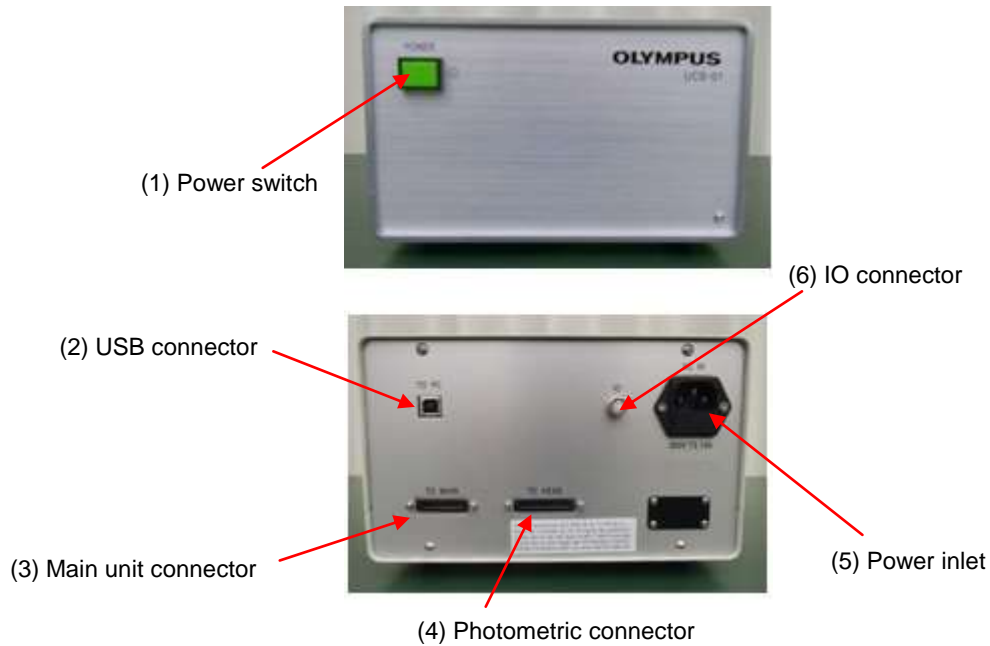

Figure 2. Control box

3.5. Features of the control box (UCB-01)

- (1) Power switch
Turns the control box power on/off.
- (2) USB connector
Terminal to send and receive the control signals. Connected with the computer via the USB cable.
- (3) Main unit connector
Terminal to supply power for sending/receiving control signals and the controller functions. Connected with the main unit via the main unit cable (DC 12V output ---).
- (4) Photometric connector
Terminal to supply power for sending/receiving control signals and the controller functions. Connected with the photometric head via the photometric cable (DC 12V output ---).
- (5) Power inlet
Supplies AC power to the control box via the power cord. This inlet also contains a fuse. For details on replacing fuses, refer to **7. REPLACEMENT OF FUSES.**
- (6) IO connector
Terminal to receive and send the control signals. Connected with the light source power supply via the IO cable.

3.6. Names of items on light source power supply (ULP-01)



Figure 3. Light source power supply

3.7. Features of light source power supply (ULP-01)

- (1) Power switch
Turns the control box power on/off.
- (2) IO connector
Terminal to receive and send the control signals. Connected with the control box via the IO cable.
- (3) Lamp connector
Connected with the lamp house via the built-in lamp cable.
(DC 12V output ---)
- (4) Power inlet
Supplies AC power to the control box via the power cord. This inlet also contains a fuse. For how to replace a fuse, refer to **7. REPLACEMENT OF FUSES.**

4. ASSEMBLING AND CABLING



Input voltage is configured to 100–120 V or 220–240 V, depending on the shipment destination. There is a label indicating the voltage setting on the back surface. Use this product within the voltage range. Otherwise, there is a risk of damage or fire. Make sure to contact our service department when you move it into a place having a different voltage range.

Assemble the unit and layout the wiring as shown in (Fig. 4):

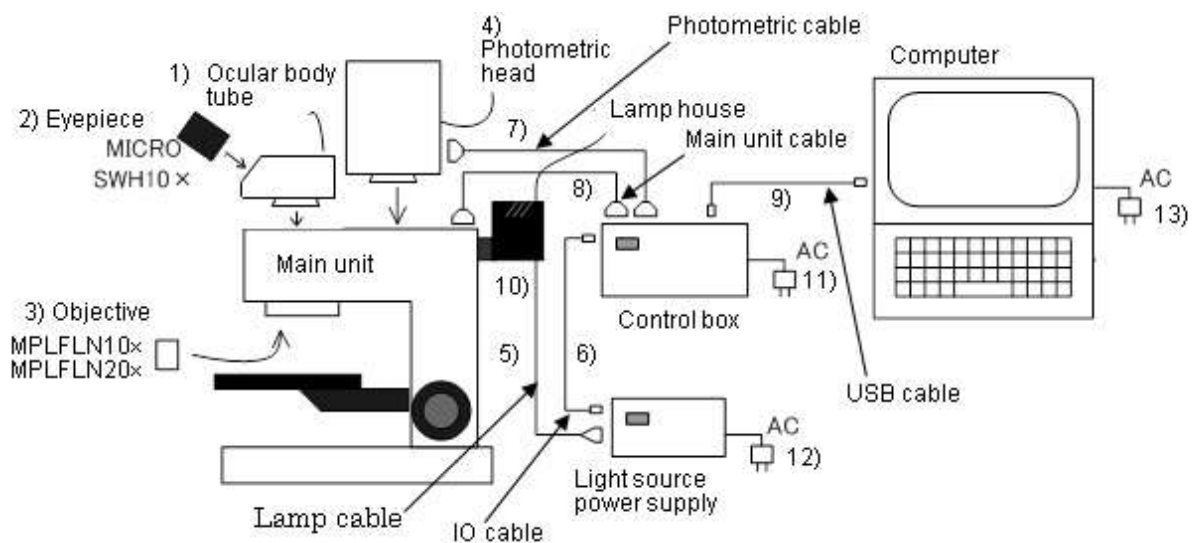
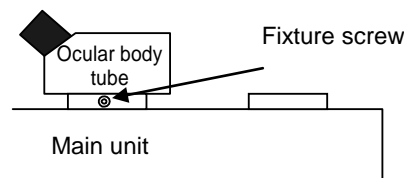

Figure 4. Assembling and Cabling Diagram

- 1) Install the ocular body tube into the main unit. Fix it with a lateral screw.
Size of the fixture screw: M5
Hexagon wrench: 2.5 mm



- 2) Insert the eyepiece (MICRO SWH10x) into the tube at the right of the ocular body tube.
- 3) Insert objective lenses (MPLFLN10x and MPLFLN20x) into the revolving nosepiece of the main unit. In a measurement, you can rotate the revolving nosepiece to place the lens you want to use into the near side.

-
- 4) Install the photometric head into the main unit. Fix it with a lateral screw.
Size of the fixture screw: M5
Hexagon wrench: 2.5 mm

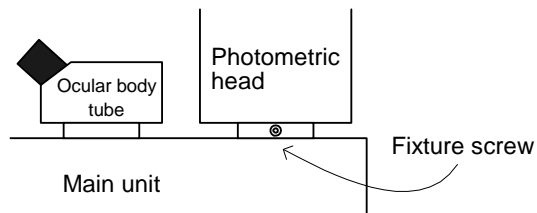

- 5) Connect the lamp cable on the lamp house to the light source power supply.
6) Connect the IO cable to the light source power supply and the control box.
7) Connect the photometric cable to the photometric head and the control box.
Connect the photometric cable in the orientation shown in Fig. 5.



Figure 5. Orientation of the photometric cable

-
- 8) Connect the main unit cable to the main unit and the control box.
Connect the main unit cable in the orientation shown in Fig. 6.

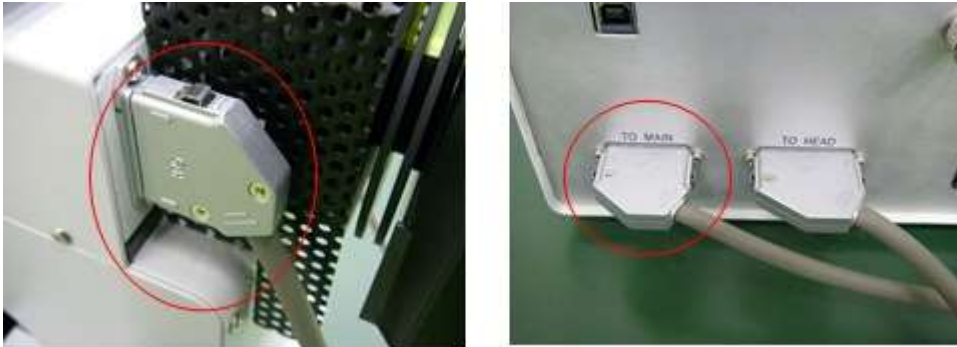

Figure 6. Orientation of the main unit cable

- 9) Connect the USB cable to the computer and the control box.
- 10) Install the lamp into the lamp house.
For how to install a lamp, refer to **8. REPLACEMENT OF LAMP.**
- 11) Connect the control box to the power supply.
- 12) Connect the power supply to the light source power supply.
- 13) Connect the computer to the power supply.

5. MEASURING METHOD



When the computer is misbehaving or any failure is found in the measurement data, plug off and reinsert USB cable and then reboot the software.

If you still have such troubles after rebooting the software, please turn off the Control Power Supply Box and then reboot the computer.

Even if you still have such trouble after rebooting the computer, please contact to us.

- (1) Turn on the power to the control box (UCB-01).
- (2) Turn on the power to the light source power supply (ULP-01).
- (3) Turn on the power to the personal computer.
* For details, refer to "USPM-RU Software Operation Manual."
- (4) Double-click the USPM icon on the computer desktop to start the program.
*If the control box power is off or the USB cable is not connected, the communication error message "**The communication encountered a device error**" is displayed. At this time, click **[OK]** to open the menu window, and choose **[File (F)]-[Quit program (X)]** in the File menu to quit the program.
The message "Save the setting?" is displayed. Click **[NO (N)]**.
As you return to the desktop, turn on the control box, and double-click the USPM icon again to launch the program.
- (5) After turning on the power to the component parts, give them 15 minutes of warming-up.
- (6) Press the **Back Ground** button on the measurement screen to conduct background measurement.
- (7) Look into the eyepiece, and adjust the diopter to bring the cross wire into focus. For this diopter adjustment, turn the helicoid of the scale (-5 to +5) of the eyepiece.

(8) Place the reference sample on the stage, and bring over the objective close to the stage. While looking into eyepiece A, move the stage away gradually to a point where the ring image (Image B) is focused into a pinhole image (Image A). When the focus has been adjusted properly, the profile of a bright pinhole image will come into sight clearly.



Image B



Image A

-
- (9) When the reference sample is in true focus, press the **Reference** button to measure its reflectance.
- (10) Press the **Measure 1** to **Measure 10** buttons with the reference sample maintained in focus, and the results of reflectance measurement of the object under measurement will be indicated.

* For details on the measurement, refer to the "USPM-RU Software Operation Manual."

6. PRINCIPLE OF MEASUREMENT

Figure 7 represents an optical diagram of the USPM3-100/USPM3-200.

In the diagram, the luminous flux that has irradiated the zonal mask turns into a parallel luminous flux as it passes through the collimator lens, and is reflected from the half mirror to go through the objective. It finally is converged into a spot of approximately 60 [μm] (when the 10x objective is used) on the sample surface.

Next, the light reflected from this sample surface comes back to the objective, and is divided into a part of luminous flux that goes through the half mirror, and another part that is returned by the half mirror and then directed to the collimator lens. The part passing through the half mirror can be observed through the eyepiece after it has passed the image-forming lens. The part of luminous flux directed to the collimator lens goes through the half mirror and is converged onto the field diaphragm FS2.

Here, the FS2 serves to prevent flare. And, the image on that end face is spectrally divided by the flat field grading and reflected from the mirror, thus allowing the spectral energy to be measured.

By the way, when the half mirror is arranged between the image-forming lens and the collimator lens, focusing of the objective onto the sample surface can be attained through the eyepiece.

Meanwhile, the eyepiece shutter in front of the eyepiece is designed to close automatically in each of the background measurement, reference measurement and sample measurement, which is meant to eliminate external light from the eyepiece during photometry.

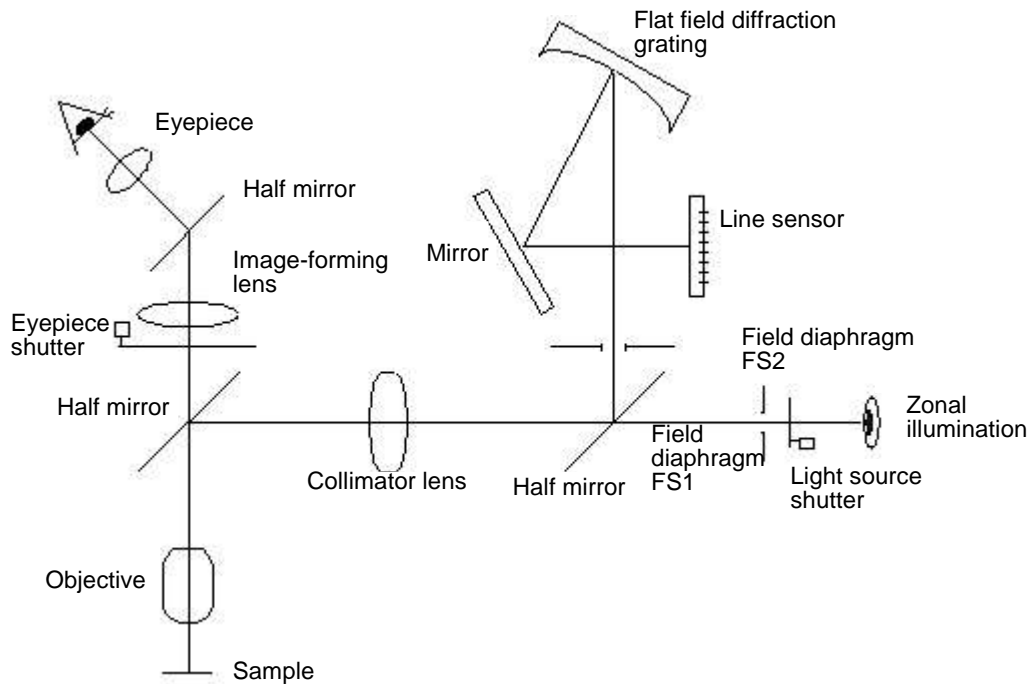

Figure 7. Optical System

7. REPLACEMENT OF FUSES

The fuse is located in a tray at the lower part of the power cord connector on the light source and control box power supplies. Determine which power supply's fuse needs to be replaced.



Unplugged

Always turn off the power and unplug the power cord before removing or installing a fuse.

Rating of fuses: 250 V AC, 3.15 A

Type of fuses: Time lag , High breaking capacity type

Size of fuses: $\phi 5.2 \text{ mm} \times 20 \text{ mm}$

Example: FIH,250V,3.15A (Made by Nippon Seisen Co.,Ltd.)

* Compatible parts available

(1) Replacement of the fuse in the light source power supply



1) Pull out the fuse tray located at the lower part of the power cord connector with a flat screwdriver on the notch.



2) Draw the tray out, pick out the fuse on the tray, insert a new fuse, and push the tray back in with your finger.

(2) Replacement of the fuse in the control box



The fuse is located in a tray at the lower part of the power cord connector. The method is similar to that for the light source box.

8. REPLACEMENT OF LAMP



To avoid electric shock and burns, always turn off the power switch, unplug the cord, and wait until the lamp is cool to the touch for replacement.



Avoid touching the halogen lamp with your finger or smudging it with dirt. Doing so can blacken or damage the bulb.



The lamp house needs inspection. Conduct regular inspections according to **Appendix: Checklist for inspection of the lighting device (lamp house)**.

- (1) Turn off the light source power supply, and unplug the power cord.
- (2) First check to make sure that the lamp is cool enough, then loosen the screw on the top of the lamp house, and remove the cover.

Size of the fixture screw: M4

Hexagon wrench: 5 mm

- (3) Pull out the lamp, with the internal lever pressed down.
- (4) Pull out the lamp, and remove it from the lamp-holder.
- (5) Install a new lamp, making sure that it is not loose.

※Though heavily dependent on the usage conditions (the ambient temperature and humidity, supply voltage, the period of lighting, etc.), the useful life of the lighting device (lamp house) is estimated to be three (3) years or 15,000 hours, whichever is shorter, assuming everyday use of about eight (8) hours. The life of the lamp assumes 50H.

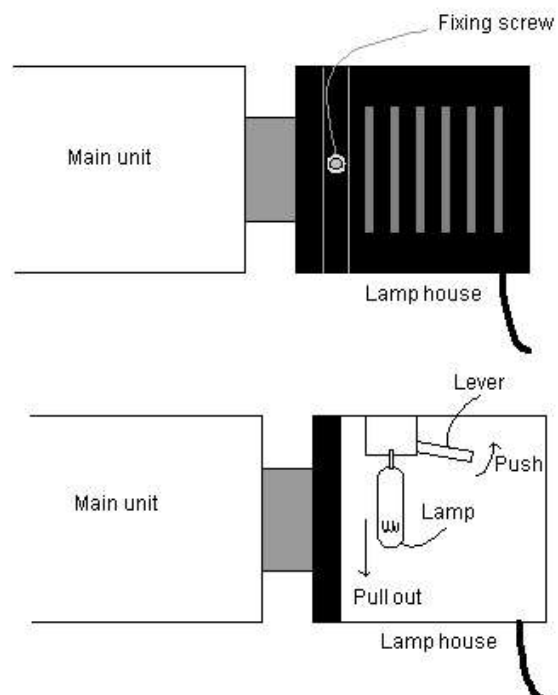
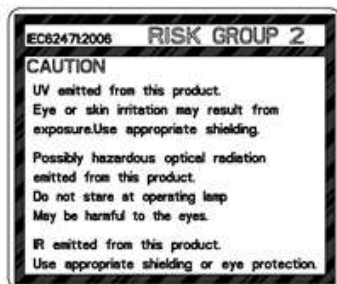

9. SPECIFICATIONS

Item	Specification
Spot diameter	Approx. 60 μm (When the 10x objective is used) Approx. 30 μm (When the 20x objective is used)
Lamp	Halogen lamp: 12 V 100 W (7023 from PHILIPS)
Stage	Size: 180×180mm Withstand load: 1 kg Operating range: (X) 80mm, (Y) 85mm, (Z) 85mm Maximum allowable temperature of stage surface is 180°C
Wavelength range	380 nm-780 nm (440 nm-840 nm on customization)
WD	MPLFLN10x: 11.0 mm MPLFLN20x: 3.1 mm
Weight	Main unit: Approx. 19.8 kg (PC and printer excluded) Light source power supply: Approx. 2.9 kg Controller: Approx. 7.5 kg
Dimensions of device	Main unit: 300(W)×550(D)×570(H)mm Light source power supply: 150(W)×250(D)×140(H)mm Control box: Approx. 220(W)×250(D)×140(H)mm
Specifications of power source	Light source power supply: 100–240 V AC, 50/60 Hz, 180 VA Control box: 100–120 V/200–240 V AC, 50/60 Hz, 85 VA (100–120 V or 220–240 V: setup when shipped)
Fuses	Light source power supply / Control box: Rating of fuses: 250 V AC, 3.15 A Type of fuses: Time lag , High breaking capacity type Size of fuses: ϕ 5.2 mm × 20 mm Shipped with: FIH,250V,3.15A (Made by Nippon Seisen Co.,Ltd.) * Compatible parts available

<p>Computer and monitor</p>	<p>-Computer CPU: Intel CPU 2.0 GHz or better, PC/AT compatible Chipset: Made by Intel Corporation (recommendation) Memory: 4 GB or greater HDD: more than 40 GB Supported OS: Windows® 10 Professional (64-bit version) Optical drive: A drive that can read a CD-ROM (external types can also be used.) Interface: USB 2.0 × 3 ports or greater EMC: Class B</p> <p>-Monitor Resolution: 1024 × 768 or greater EMC: Class B</p>
<p>Usage environment</p>	<p>Indoor use Altitude: Up to 2,000 m Temperature: 10°C-30°C (no sudden changes) Humidity: 15%-85% (non-condensing) Voltage fluctuation: ±10% Contamination: 2 (in accordance with IEC60664-1) Installation Category: II (in accordance with IEC60664-1)</p>

10. LAWS AND REGULATIONS

10.1. About FCC

NOTE: This equipment has been tested and found to comply with the limits for a Class A digital device, pursuant to Part 15 of the FCC Rules. These limits are designed to provide reasonable protection against harmful interference when the equipment is operated in a commercial environment. This equipment generates, uses, and can radiate radio frequency energy and, if not installed and used in accordance with the instruction manual, may cause harmful interference to radio communications.

Operation of this equipment in a residential area is likely to cause harmful interference in which case the user will be required to correct the interference at his own expense.

FCC WARNING: Changes or modifications not expressly approved by the party responsible for compliance could void the user's authority to operate the equipment.

10.2. About KC (For Korean Customers)

A급 기기 (업무용 방송통신기자재)

이 기기는 업무용(A급) 전자파적합기기로서 판매자 또는 사용자는 이 점을 주의하시기 바라며, 가정외의 지역에서 사용하는 것을 목적으로 합니다.

10.3. About disposal

Follow the state and local regulations and ordinances when disposing of the product.

10.4. Chinese RoHS Directive



This mark indicates the environmental protection use period applicable to electronic information products sold in China in accordance with the “Management Methods for Controlling Pollution by Electronic Information Products” of February 28, 2006 and the “Requirements Concerning Pollution Control Markings for Electronic Information Products.”

(Caution)

During the environmental protection use period harmful substances will not be emitted when used under proper conditions. However, it does not guarantee functional performance of the product during the said period.

10.5. Energy consumption

To reduce energy consumption, turn off this Product when it is not in use. The computer consumes standby electricity even in the power-off state. Energy consumption is reduced when the power cord is unplugged when it is not in use.

Standby electricity and power consumption of computers is different between models.

Confirm the ratings in your computer’s documents. (FYI: A typical computer consumes about 1 W of standby electricity and about 25 W of active power, while active power often increases to 50 W depending on the peripherals and applications in use.)

11. QUALITY ASSURANCE (WARRANTY SHEET)

*****WARRANTY CARD*****			
(Product name)	Lens Spectral Reflectivity Measurement		
(Model)	USPM3-100/USPM3-200		
<u>Customer Identification</u>			
Name:	_____		
Address:	_____		
Phone number:	_____		
(Warranty period)	One year from the acceptance inspection date		
(Acceptable inspection date)	year	month	day

(Warranty provisions)

Through this Warranty Card, Olympus Corporation commits itself to repair the product, free of charge, subject to the provisions set forth herein.

(Provisions for charge-free repair)

- (1) If a malfunction occurs due to a manufacturing defect within the validity of the warranty period while the product is used properly in accordance with the instruction manual and the caution labels on the main unit, Olympus Corporation will repair the product free of charge.
- (2) This warranty does not apply in the event that the product fails to operate normally due to other factors (e.g., peripheral devices, environment in which the product is installed, etc.).
- (3) Even within the validity of the warranty period, the product will be repaired at the user's charge in the following cases:
 - Malfunction or damage arising from inadequate way of use.
 - Malfunction or damage arising from natural disasters (lightning, flooding, etc.) or other unforeseen accidents.
 - When the cause of the malfunction resides in device other than this

product.

- Malfunction or damage of a part repaired, adjusted, or improved by any persons other than Olympus Corporation's service personnel, and a malfunction or damage arising from that part.
- Product whose machine number has intentionally been altered or removed.
- Consumables and articles similar to those.

(4) For details on how to have defects repaired in Japan or overseas, contact the support division listed in the attachment.

* The warranty card guarantees any free-of-charge repair under the terms and conditions specified in this document. The warranty is not intended to restrict the rights of the customer. Even after the warranty period, the service department at Olympus will gladly welcome any questions. Contact the support division listed in the attachment.

- Although we try to ensure the accuracy of the contents of the document, however, should there be any mistakes or omissions, or if you have any questions, please contact the service division listed in the attachment.
- Notwithstanding the foregoing, we cannot be held responsible for any influence caused by using the measurement results of this product.

APPENDIX

○ Principle of calculating spectral reflectance

How to calculate spectral reflectance with the product is described below.

The product measures the strength of spectral reflectance of the reference, whose reflectance is known ($I_{reference}(\lambda)$) and that of the sample to be measured, whose reflectance is unknown ($I_{sample}(\lambda)$). Based on the two spectral reflectance values, use the following formula to calculate the reflectance of the sample under measurement. Therefore, the measurement value output from the product is not an absolute value but a relative value against the reference sample.

$$R_{(\lambda)} = \frac{I_{sample(\lambda)} - I_{background(\lambda)}}{I_{reference(\lambda)} - I_{background(\lambda)}} \cdot R_{theory(\lambda)}$$

$R_{(\lambda)}$: Measured value of the spectral reflectance of the sample

$I_{sample(\lambda)}$: Strength of spectral reflectance of the measured sample

$I_{reference(\lambda)}$: Strength of spectral reflectance of the reference

$I_{background(\lambda)}$: Strength of background

$R_{theory(\lambda)}$: Theoretical value of the spectral reflectance of the reference

○ Precautions for safe use of the lighting device (lamp house)

- Though heavily dependent on the usage conditions (ambient temperature and humidity, supply voltage, period of lighting, etc.), the useful life of the lighting device (lamp house) * assumes either short one of for approximately three years (In the case of the use of approximately eight hours a day) or approximately 15,000 hours .

*The above statement does not guarantee freedom from failures or repair at no charge during the service life.

* Depending on the usage conditions, there is a possibility of aging degradation in a shorter period.

Inspect the lamp house according to **Appendix: Checklist for inspection of the lighting device (lamp house)** until the lamp house reaches the end of its useful life.

Should any unexpected incident occur (e.g., smoke) during use, turn off the power immediately and contact the sales representative where you purchased the unit or our sales department. Regular inspection is recommended, in order to achieve safe use and reduce downtime.

Checklist for inspection of the lighting device (lamp house)

- Read the manuals carefully before performing lamp house inspections.
- Inspections on a regular basis (at least once every half year and at the time of lamp replacement) is recommended in order to ensure safe use.
- Inspect the items in the list, and mark an X next to each passed item and a circle next to each item having some problem.
- If there are any circled items in the latest inspection, **stop using** the unit and ask the agent to inspect the unit or to replace it with a new lighting device.
- If you discover a failure in any items not on the list or a failure in any other components of our product, other than the lighting device, **stop using** the unit and ask your supplier to inspect the unit.
- Repairs, replacement and inspections out of warranty are available for a fee. Contact your supplier with any questions you may have.

Inspection checklist	Result (date of inspection)			
	/	/	/	/
1. Eight years have elapsed since purchase, or the total time of lamp use has exceeded 20,000 hours.				
2. Sometimes lamp does not illuminate even when you turn on the main switch (except for discharge-type lamps ^{*1}).				
3. The light blinks if you move the lamp cable or the body itself.				
4. The lamp cable or another part is abnormally hot.				
5. There is an odor like something is burning when in use.				
6. Light flickers even after the lamp is replaced (except for discharge-type lamps ^{*1}).				
7. A deformation, unsteadiness or loose part is discovered when installing the lighting device (e.g., a cover is too tight to open).				
8. The color of any terminal or the lamp socket is drastically changed. Or, the color is different between the left one and the right one (except for discharge-type lamps ^{*1}).				
9. There is change of color, deformation or cracks in the appearance of the device.				
10. There is melting, cracks, deformation or solidification in the lamp cable or wiring.				
11. Frequency of repair is higher than before for the same type of other units brought into service around the same time.				

* Make a copy of the list if you find some of the check result fields have already been used.

*1 Discharge-type lamps: mercury lamps, xenon lamps, and metal halide lamps

○ Precautions for proper use of the power cord

When no power cord is attached to the product, refer to the "Specification" and "Certification codes" below to choose a proper power code for the unit.



We do not guarantee the electrical safety of the product, if an incorrect power cord is connected to the product.

Specification

Rated Voltage	125 V AC (100–120 V AC), 250 V AC (220–240 V AC)
Rated Current	6 A minimum
Rated Temperature	60°C minimum
Length	3.05 m maximum
Components	Grounded inlet plug, with the opposite end formed in compliance with IEC

Table 1. Certification codes

The power cord must be certified by any one of the certification organizations in Table 1, or be associated with any one of the certification marks shown in Table 1 and/or Table 2. The connector must be associated with any one of the certification marks in Table 1. If no cords certified by any of the certification organizations in Table 1 are available in the country where you use the product, use a substitute certified by the certification body of the country or any similar organization.

Country	Certification organization	Certification mark	Country	Certification organization	Certification mark
Argentina	SAA		Italy	IMQ	
Australia	SAA		Japan	JET, JQA, TUV, UL-APEX/MITI	
Austria	ÖVE		Netherlands	KEMA	
Belgium	CEBEC		Norway	NEMKO	
Canada	CSA		Spain	AEE	
Denmark	DEMKO		Sweden	SEMKO	
Finland	FEI		Switzerland	SEV	
France	UTE		UK	ASTA, BSI	
Germany	VDE		USA	UL	
Ireland	NSAI				

Table 2. HAR flexible codes
 Certification organizations and code labels

Certification organization	Labels (Probably marked on the cover or insulating part in the internal wiring)		Replacement symbol with black-red-yellow line Length (mm)		
			Black	Red	Yellow
Comite Electrotechnique Belge (CEBEC)	CEVEC	<HAR>	10	30	10
Verband Deutscher Elektrotechniker (VDE) e.V.Prüfstelle	<VDE>	<HAR>	30	10	10
Union Technique de d'Electricite' (UTE)	USE	<HAR>	30	30	10
Instituto Italiano del Marcio di Qualita' (IMQ)	IEMMEQU	<HAR>	10	30	50
British Approvals Service for Electric Cables (BASEC)	BASEC	<HAR>	10	10	30
N.V. KEMA	KEMA-KUER	<HAR>	10	30	30
SEMKO AB Svenska Elektriska Materielkontrollanstalter	SEMKO	<HAR>	10	10	50
Österreichischer Verband für Elektrotechnik (ÖVK)	<ÖVK>	<HAR>	30	10	50
Danmarks Elektriske Materielkontrol (DEMKO)	<DEMKO>	<HAR>	30	10	30
National Standards Authority of Ireland (NSAI)	<NSAI>	<HAR>	30	30	50
Norges Elektriske Materielkontroll (NEMKO)	NEMKO	<HAR>	10	10	70
Asociacion Electrotecnica Y Electronica Espanola (AEE)	<UNDE>	<HAR>	30	10	70
Hellenic Organization for Standardization (ELOT)	ELOT	<HAR>	30	30	70
Instituto Portugues da Qualidade (IPQ)	np	<HAR>	10	10	90
Schweizerischer Elektro Technischer Verein (SEV)	SEV	<HAR>	10	30	90
Elektriska Inspektoratet	SETI	<HAR>	10	30	90

Underwriters Laboratories Inc. (UL)
 Canadian Standards Association (CSA)

SV, SVT, SJ or SJT, 3 X 18AWG
 SV, SVT, SJ or SJT, 3 X 18AWG

Printed in Japan © 2011 Olympus Corporation. All rights reserved.

Unless otherwise stated in this document, no content in whole or in part may be copied or distributed without permission.

Company names and product names described in this document are trademarks or registered trademarks of their respective owners.

USPM-RU Ver3.21.004

Software Operation Manual

OLYMPUS®

PREFACE

Before you get started

Thank you for purchasing Olympus USPM-RU Ver.3.21. Before you start using it, please be sure to read this operation manual carefully, and then, store it in a readily accessible safe place, so that it can be referred to at any time you need it.

Description of Symbols and Terms Used in This Instruction Manual

The following symbols and terms are introduced in the description of this manual.



Failure to follow the instructions associated with this symbol could result in malfunction.

Contents

PREFACE	1
1. General	3
2. Tutorial (Measuring Procedure)	4
3. Main Window	10
4. Menu List	15
5. Details of [File] Menu	17
6. Details of [Display] Menu	20
7. Details of [Standard] Menu	27
8. Details of [Analyze] Menu	31
9. Details of [System] Menu	42
10. [Help] Menu	47
11. About the Calibration Method for Wavelength Direction ..	48
12. File Configuration	51
13. About the Alarm and Error Indications	59
14. Precautions	63
15. USPM Setup Procedure	64
16. Contact Address	67
17. SOFTWARE LICENSE AGREEMENT	68

1. General

USPM-RU Ver.3.21 is a control software for a spectral reflectivity measurement system with measurement wavelengths ranging from 380nm to 780nm (or, 440nm to 840nm). Since it stores the measuring conditions for different types of measurement objects (i.e., samples), user-set optimum conditions can be set up again instantaneously when the stored file is called up. Moreover, the dispersion data possessed by the reference can be selected from fixed values and dispersion equations, thereby allowing the user to select an arbitrary reference reflective object.

2. Tutorial (Measuring Procedure)

2.1. Hardware starting procedure



Failure to follow the procedure may result in abnormal operation. In such a case, turn of the power again. Then start up the program according to the following procedure.

- (1) Turn on the power of the control box.
- (2) Turn on the light source power.
- (3) Turn on the printer power.
- (4) Turn on the personal computer.

2.2. Hardware shutdown procedure

Always close the USPM software and shutdown Windows before turning off the power to the other devices (in any order).

2.3. Launching procedure for USPM-RU Ver.3.21

- (1) After turning on the personal computer, check to make sure that Windows is started and that the icon screen is displayed.
- (2) Double-click the USPM-RU (or USPM-RU440) icon on the desktop, or select USPM-RU (or USPM-RU440) from the Windows Start menu. The program will be launched, causing the Main Window to open.

Note: If, in the above operation, the control box has the power switched off, a communication error will be displayed. If that is the case, click **[OK]**, and when the menu screen opens, select **[File (F)] - [Quit (X)]** from the File menu to close the program briefly.

As the message "Save changes to the configuration file?" will be displayed, select **[No]**. When you are returned to the icon screen, turn on the power of the control box, and then click the USPM icon again.

2.4. Closing procedure for USPM-RU Ver.3.21

- (1) Click **[File (F)]** and select **[Quit (X)]**. The message "Save changes to the configuration file?" will be displayed. Select and click **[Yes]**, **[No]**, or **[Cancel]**. You will be returned to the icon screen through which the program was started before.
- (2) Click the **[Start]** button to exit Windows.

The Main Window of USPM-RU Ver. 3.21 shows various buttons. These buttons enable you to measure spectral reflectance. To find the spectral reflectance of a sample, i.e., object under measurement, conduct measurement by using the procedure described below.

2.5. Focusing method

- (1) How to find lens vertex (lens center)

Place the lens under measurement on the stage, and adjust the Z-stage, so that the vertex is situated roughly in the position of WD (Operating distance = Distance from the tip of the objective, 10mm in the case of ULMLPL10X). In this condition, look into the right-hand eyepiece, and you will see two donuts of light (if the two light donuts are not observed, adjust the XY-stages a little. Notice, however, that no more than one light donut will be observed if the lens under measurement is thicker than WD.)

Then, adjust the XY-stages, so that the two light donuts will be overlapped concentrically one on the other, as illustrated in Figure 2. If only one light donut is observed, adjust the XY-stages in such a manner that its center is aligned to that of the reticle of the eyepiece.

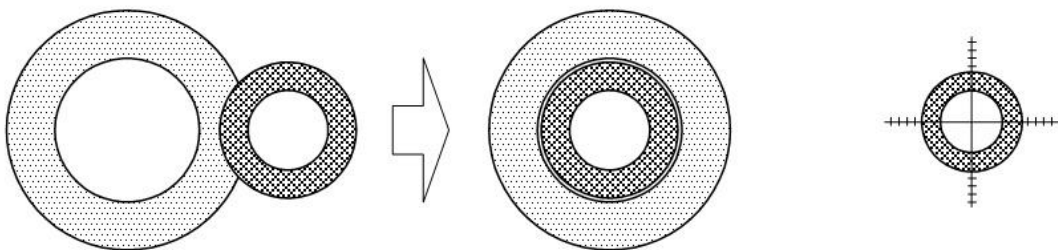

Align the centers.

Figure 1

Figure 2

Figure 3

(2) How to find the front spot (How to discriminate between the front spot and the back surface spot.)

- 1) When the light donuts are laid one over the other concentrically, lower the Z-stage gradually while looking into the right-hand eyepiece, with the lens under measurement brought close to the objective. Then, the back surface will come into focus in the position shown in Figure 4, forming a spot.
- 2) Then, as the Z-stage is gradually lowered by the thickness of the lens under measurement, the front surface will now come into focus in the position shown in Figure 5, and a spot, formed.

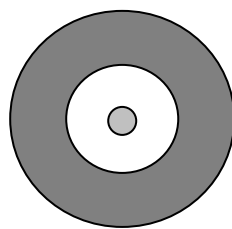
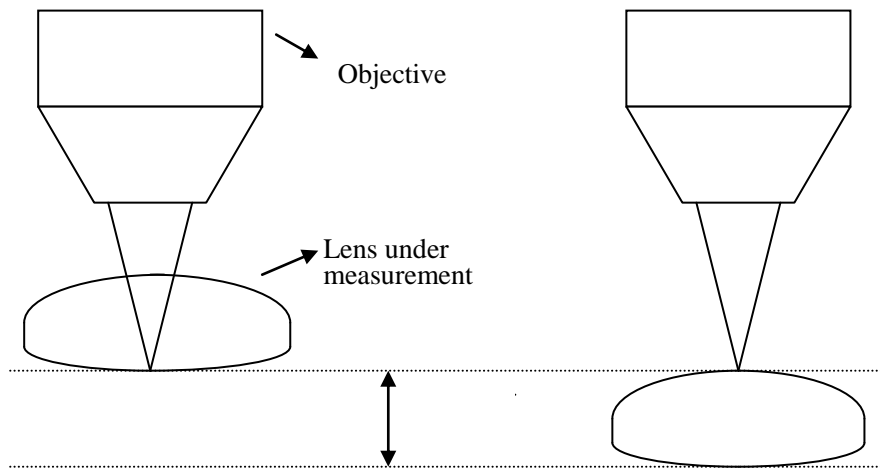

Figure 4

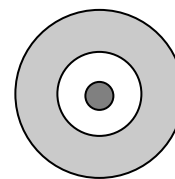

Figure 5

2.6. Measuring procedure

- (1) Perform warming-up for some 15 minutes after turning on the halogen lamp. Place the reference (BK7) supplied in the same package on the stage, and bring the reflection spot into focus while looking into the right-hand eyepiece.
- (2) Click the **[Background]** button.
- (3) Click the **[Reference]** button.
- (4) Replace the reference with the sample, and bring the reflection spot into focus.
- (5) Click any of the **[Measure1]** to **[Measure10]** buttons.
- (6) The measurement result will be displayed on the Main Screen.

Note: If, in this condition, the message "Light intensity is too high" appears, click the menu **[Display]**, check **[Light graph]**, and click the **[Monitor]** button.

Set (shorten) the sampling time in the sampling setup window of the **[System Setup]** menu, so that the maximum value of the measured data comes into the neighborhood of 4000 on the ordinate scale. Once the appropriate sampling time is set up, click **[Display]** to check the reflectance graph, and restore the reflectance graph. Load the reference again on the stage, and measure it by using the procedure of the **[Background]** and **[Reference]** buttons. Then, replace the reference with the sample, and click any of the **[Measure1]** to **[Measure10]** buttons.

Set the sampling time in such a manner that the quantity of light of the reference or sample, whichever has a higher reflectance, will fully extend over the dynamic range (neighborhood of 4000 when raw data is displayed).

2.7. Selection of measurement data

- **[☉]** button

The radio button located to the left of the Measure button is a data selection button. It indicates whether or not data is currently selected.

2.8. Deletion of measured data

- **[Data Clear]** button

Clears the data currently selected.

- **[All Clear]** button

Clears all the measured data.

2.9. To find the reflectance for each wavelength

When any of the [**<<**][**<**][**>**][**>>**] buttons on the cursor panel at the lower right is pressed, the cursor moves over the graph of spectral reflectance data, and the wavelength [nm] and [Reflectance [%]] of the position where the cursor is located are indicated. [See "3.4 Cursor panel" in Section 3.]

2.10. How to find the chromaticity coordinates (440nm - 840nm excluded)

Simultaneously with the measurement of spectral reflectance data, USPM-RU Ver.3.21 calculates the corresponding chromaticity coordinates on the chromaticity diagram panel, shows the numeric values of the coordinates, and indicates the position on the chromaticity diagram with the cursor. Moreover, the software displays the hue angle, chroma, mean reflectance, and luminous reflectance. The field and the type of light source currently selected are also indicated on the chromaticity diagram panel. [See "3.2 Chromaticity diagram panel" in Section 3.]

2.11. How to calculate color difference (440nm - 840nm excluded)

Click **[Color difference]** of the **[Analyze]** menu.

Select any two data points in the color difference measurement window, and click the **[Calculation]** button. Then, the result will be displayed. [See "8.4 [Color difference measurement] menu" in Section 8.]

2.12. How to save spectral reflectance data

Click **[File]** at the top of the Main Window, and select **[Save as]**. The test info window will

appear. Enter any desired test No., measuring position, measurer's name, coating device No., and measurement date, and then click the **[OK]** button. Next, the **[Save File As]** window will be displayed. Select the target directory, key in the file name, and click **[Save]**. This operation will save the measured spectral reflectance data on the disk.

2.13. How to display saved spectral reflectance data

Click **[File]** at the top of the window, and select **[Open]**. The **[Open File]** window will appear. Select the target directory and file name, and click **[Open]**.

This operation will allow the spectral reflectance data saved on the disk to be loaded to the computer, and the measurement results will be displayed.

2.14. How to output measurement results to a printer

Selecting **[File][Print]** causes the **[Print]** window to open. Click **[Print]**, and the measurement results will be output to the printer. [See "5.8 [Print] menu" in Section 5.]

3. Main Window

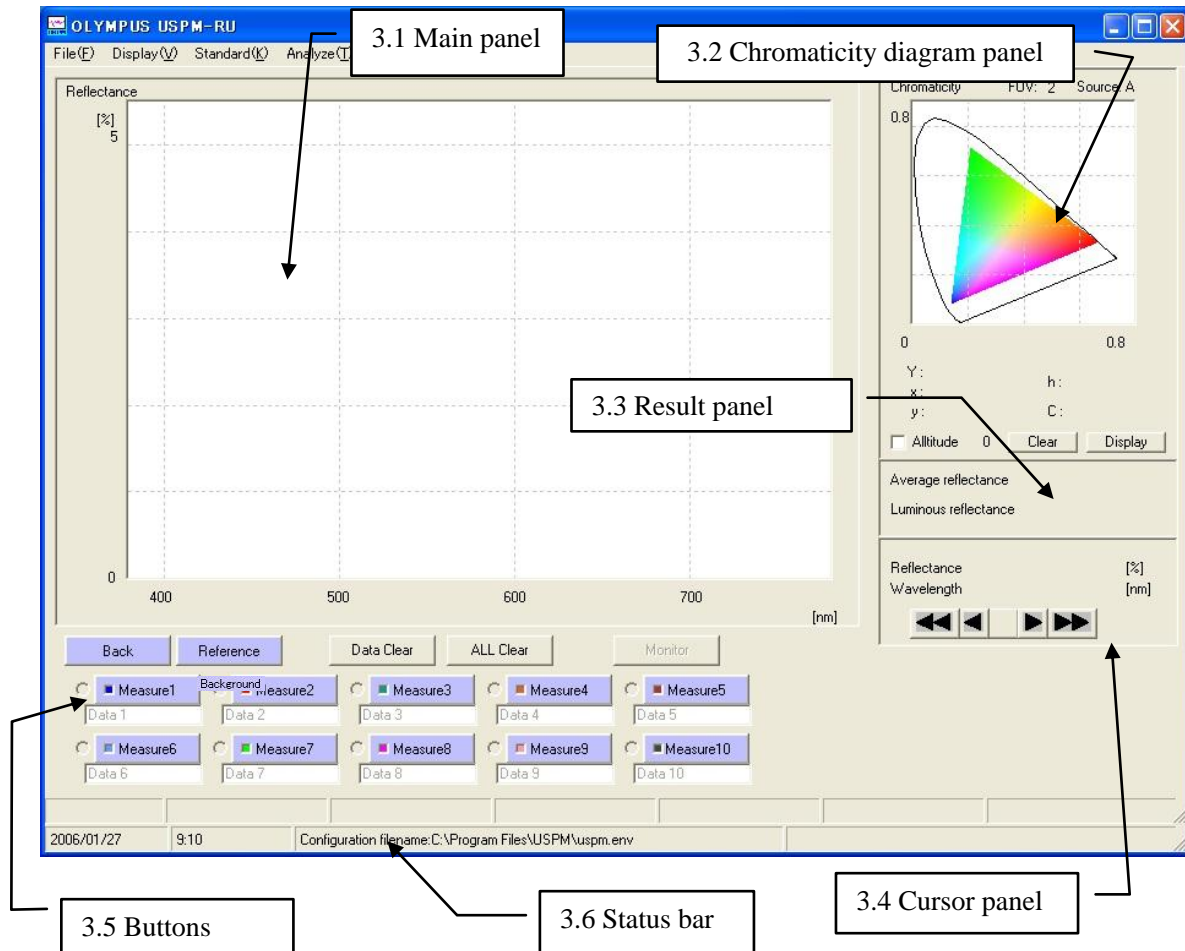

3.1. Main panel

After measurement, this panel displays any of the following measured data, according to the settings made through the **[Display]** menu:

- Spectral reflectance graph
- Spectral reflectance data text
- Refractive index graph
- Quantity of light graph data
- Quantity of light text data
- Chromaticity diagram (440nm - 840nm excluded)
- $1/\lambda$ indication

3.2. Chromaticity diagram panel (440nm - 840nm excluded)

This panel shows the color information of measurement results at all times. The chromaticity diagram panel is displayed according to the settings of the **[Chromaticity diagram]** tab of **[Display][Graph setting]**. The fields (2°, 10°) and light sources (A, B, C, D65) currently specified are indicated at the top of the chromaticity diagram.

As for the coordinates of measurement data, the point and its coordinates (Y, x, y) or (L, a, b) are indicated on the chromaticity diagram. Moreover, the hue angle h° and chroma C^* are shown at the same time.

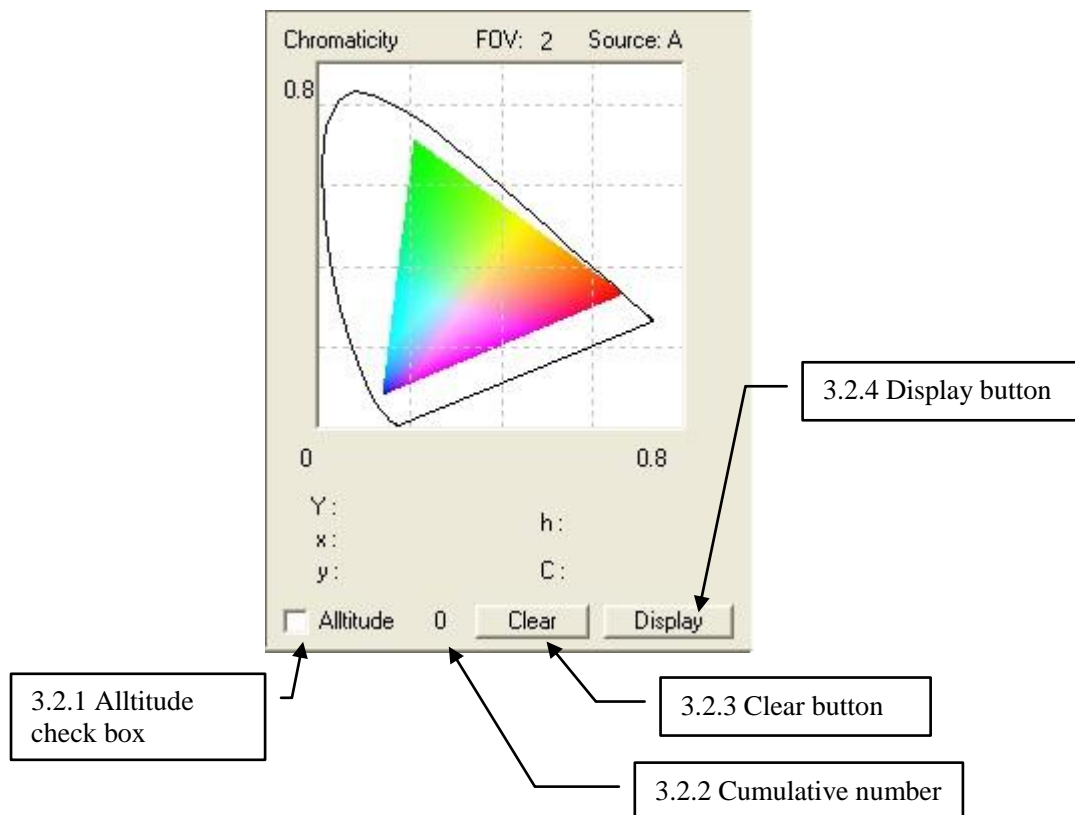

3.2.1. Allitude check box

When this box is checked, the measured chromaticity diagrams are automatically accumulated.

3.2.2. Cumulative number

Indicates the number of accumulated data points. The upper limit of the data count is 100.

3.2.3. Clear button

Deletes accumulated data starting from the newest one.

3.2.4. Display button

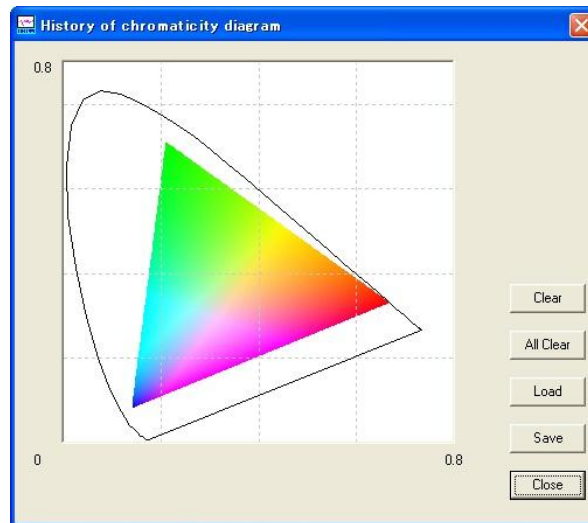

This button displays the accumulated chromaticity diagram data.

This chromaticity diagram window has [Clear], [All Clear], [Save], [Load], and [Close] buttons.

[Clear] button : Deletes data sequentially starting from the newest one.

[All Clear] button : Deletes all the chromaticity diagram data.

[Save] button : Saves cumulative chromaticity diagrams under the different names assigned.

[Load] button : Loads and displays a cumulative chromaticity diagram file.

[Close] button : Closes the window.

3.3. Result panel

This panel is for indicating the mean reflectance and luminous reflectance of measurement results. The result panel shows the values of mean reflectance R_m and luminous reflectance R_v after measurement. It indicates the data selected with the radio buttons.

3.4. Cursor panel

This panel is for cursor-related operations and indications.

Pressing the [←], [←], [→] and [→] buttons on the cursor panel moves the cursor over the graph of the panel. When reflectance is displayed on the panel, wavelength [nm] and reflectance [%] of the

position where the cursor is located are indicated. When refractive index is displayed on the panel, wavelength [nm] and refractive index [n] of the cursor position are indicated. When the quantity of light is displayed on the panel, wavelength [nm] and the value of the quantity of light are indicated. When reflectance text or the chromaticity diagram is displayed on the panel, the cursor panel remains inactive.

[<] and **[>]** move the cursor in steps of one [nm], while **[<<]** and **[>>]** actuate the cursor in steps of 10 [nm]. When the button in the center of the cursor button is pressed, the jump window will appear. Enter the wavelength of the jumping destination and press the **[OK]** button. A jump will take place to the specified wavelength. When multiple data are displayed, a jump will take place to the data selected with the radio button.

*) The cursor can be moved with "SHIFT" + "<" or ">", or "Ctrl" + "<" or ">" in the same way as with **[<<]**, **[<]**, **[>]**, and **[>>]**.

3.5. Buttons

- **[Background]** : Executes background measurement.
Similarly, pressing the "F11" key executes background measurement.
- **[Reference]** : Executes reference measurement.
Similarly, pressing the "F12" key executes reference measurement.
- **[Measure1] to [Measure10]** : Executes sample measurement.
Similarly, pressing the "F1" to "F10" keys executes sample measurement.
The data line is displayed in the color shown on the button.
- **[Data name input box]** : Measured data can be assigned any name entering in the input box located below the Measure button. (The name assigned here is treated as a test No.)
- **[Monitor]** : This button is active only when Quantity of Light Graph and Quantity of Light Text are selected in the [Display] menu. It shows a quantity of light graph.
- **[☉]** : The radio buttons located on the left of the **[Measure]** buttons are for selecting data. They indicate whether the data is currently selected or not.
- **[Data Clear]** : Clears the measured data currently selected with a radio button.
- **[All Clear]** : Clears all the measured data.

3.6. Status bar

The status bar indicates the following items:

- Date : Indicates the current date of the personal computer.
- Time : Indicates the current time of the personal computer.
- Standard judgment result : When standards are specified, this item indicates whether the measured data meets those standards or not.
- Configuration file name : Indicates the current configuration file name.

4. Menu List

4.1. [File] menu

- **[Open]:** Opens a measured data file and loads it to the computer.
- **[Save as]:** Saves measured data to a file named arbitrarily.
- **[Open config file]:** Opens an configuration file and loads it to the computer.
- **[Replace configuration file]:** Saves an configuration file under the current file name.
- **[Save as]:** Saves an configuration file under an arbitrary name assigned.
- **[Print Setup]:** Sets up a printer.
- **[Print]:** Executes various types of prints.
- **[Quit]:** Dismisses a program.

4.2. [Display] menu

- **[Reflectance graph]:** Displays a reflectance graph.
- **[Reflectance text]:** Displays a reflectance text.
- **[Refractive index graph]:** Displays a refractive index graph.
- **[Light graph]:** Displays data from the spectrometer as it is in a graph.
- **[Light text]:** Displays data from the spectrometer as it is in a text.
- **[Chromaticity diagram]:** Displays an enlarged view of the chromaticity diagram located at the upper right. (440nm - 840nm excluded)
- **[Reciprocal wavelength]:** Displays reflectance data when wavelength is indicated in a reciprocal number.
- **[Graph setting]:** Used to make settings related to graph indications.
- **[Setting List]:** Displays a listing of configuration settings.

- **[Additional Data]**: Opens a test information input screen when saving data.

4.3. [Standard] menu

- **[Standard setting]**: Used to set standards.

4.4. [Analyze] menu

- **[Film thickness setting]**: Used to make settings for a film thickness measurement.
- **[Wavelength list]**: Displays the wavelength detected in a film thickness measurement.
- **[Film thickness graph]**: Displays a film thickness history graph.
- **[Color difference]**: Calculates and indicates color difference ΔE . (440nm - 840nm excluded)

4.5. [System] menu

- **[Reference setting]**: Used to make reference data setup.
- **[Sampling]**: Used to make system setup.
- **[Calibration]**: Used to make wavelength calibration setup.

4.6. [Help] menu

- **[Version]**: Indicates the version of USPM-RU is Ver. 3.21.

5. Details of [File] Menu

5.1. [Open] menu

Opens a measured data file and loads it to the computer. The loaded data is displayed on the reflectance panel and chromaticity diagram panel in accordance with the various settings made (Reflectance and refractive index graph indications, or refractive index text indication, etc.). When **[Light Graph]** or **[Light Text]** is currently selected in the **[Display]** menu, nothing is displayed on the Main Panel. Pressing the **[Cancel]** button aborts the data load.

5.2. [Save as] menu

	Test No.	Notes1	Notes2	Date
Data1	Data 1			0:00:00
Data2	Data 2			0:00:00
Data3	Data 3			0:00:00
Data4	Data 4			0:00:00
Data5	Data 5			0:00:00
Data6	Data 6			0:00:00
Data7	Data 7			0:00:00
Data8	Data 8			0:00:00
Data9	Data 9			0:00:00
Data10	Data 10			0:00:00

OK Cancel

Saves measured data to a file. The Test info input window opens. Enter the test No., Notes 1, Notes 2, and date. The test No. should be entered in not more than eight characters. Clicking the **[OK]** button causes the **[Save File As]** window to open. Enter the names of the storage directory and file, and click the **[Save]** button. If you click the **[Cancel]** button, you will be returned to the Main Window, without the data being saved. Saved data file format is selected three type listed below..

File Type	Explanation
Data File(*.csv)	Normal file format from 3.20. When the data is saved, reflectance data(*.csv) and additional data(*add.csv) are created.

Data File(*.dat)	This format is equal to previous version software like 1.10 or 2.00. All measured data point is saved. Additional data is not created
Data File(5)(* .dat)	This format is equal to previous version software like 1.10 or 2.00 .Only 5 measured data points are saved. An additional data is not created.

If saved reflectance data is to be loaded as a board refractive index file, save the data as "Data1".

5.3. [Open config file] menu



Although configuration file of previous version like 1.10 or 2.00 can be opened, standard file and formula2 data of reference and film thickness setting can't be opened. So that parameter is set to default.

Opens an configuration file and loads it to the computer. The configuration file is one that stores the measurement setup parameters of USPM-RU. When an configuration file with optimum settings is created for each sample under measurement in advance, the measurement settings will be able to be reproduced by simply loading that file.

The measurement setup parameters currently specified can be verified in the **[Setting list]** window, which is opened through **[Display]** and **[Setting list]** Menu. The current configuration file name is indicated in the status bar of the Main Window.

5.4. _[Replace config file] menu

Saves measurement setup parameters under the current configuration file name by overwriting the currently specified parameters.

5.5. [Save as] menu

Saves an configuration file by assigning an arbitrary name to it. When a file is named and saved, the configuration file name currently in use is rewritten with this new file name.

5.6. [Print Setup] menu

Used to open the **[Print]** window and set up a printer.

5.7. [Print] menu

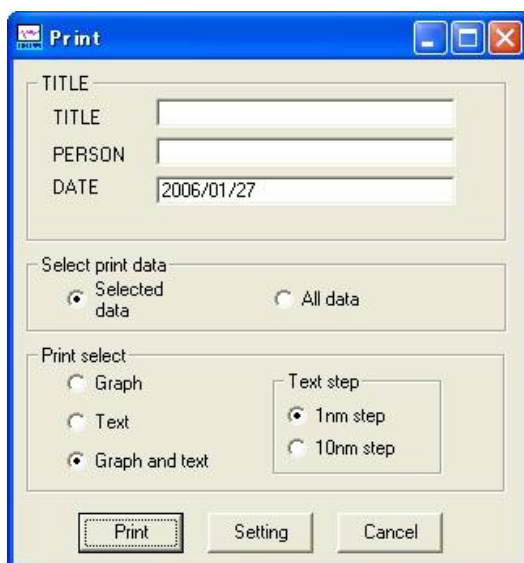

Opens the **[Print]** window to execute various types of printing. On the **[Print]** window, selection is made from the graph print, text print, graph+text print, and the number of text steps (1nm/10nm). The graph print outputs a reflectance graph or refractive index graph directly to a printer. The text print outputs a wavelength and the reflectance at that wavelength in numeric values. When the title, date, and person are entered through this window for printing, the entered characters are inserted in the Main Window, in the case of a graph print, or at the top of the print, if it is a text print.

If the **[Print]** window is opened while a quantity of light graph or quantity of light text is displayed, the selections made will be invalidated, and the inputs of the title, date, and person only will remain valid. And, the quantity of light graph is output to the printer.

5.8. [Quit] menu

The message "Save changes to the configuration file?" appears.

[Yes] Saves by overwriting.

[No] Closes the program without priorly saving.

[Cancel] Aborts the program closing processing.

When standard data are specified as configuration parameters, but not saved to a file (when no file name is found), the software will display the message "Save changes to the standard file?"

If you press the **[OK]** button to save the file, you will be able to save it by entering a standard file name.

6. Details of [Display] Menu

[Display] of the Main Menu is selected to make settings related to the indications of USPM-RU.

6.1. [Reflectance graph] menu

Displays measured spectral reflectance data in a graph on the reflectance panel.

When checked at the start, **[Reflectance graph]** displays measured data in a graph, with wavelength [nm] on the abscissa, and reflectance [%] on the ordinate.

6.2. [Reflectance text] menu

Displays, in a text, the reflectance data string for each wavelength in the area where the graph was displayed. The wavelength is indicated on the left-hand end of the line, followed by the reflectance data.

6.3. [Refractive index graph] menu

Displays measured refractive index data in a graph on the refractive index panel. The displayed graph has wavelength [nm] on the abscissa, and refractive index [n] on the ordinate.

6.4. [Light graph] menu

Indicates quantity of light. The graph shows data from the spectrometer as is, with wavelength [nm] on the abscissa, and the scale of the abscissa set to maximum 4000.

6.5. [Light text] menu

Indicates quantity of light in a text. It shows the quantity of light data for each wavelength in a text in the area where the graph was displayed.

6.6. [Chromaticity diagram] menu (440nm - 840nm excluded)

Shows an enlarged view of the chromaticity diagram displayed at the upper right, in the area where the graph was displayed.

6.7. [Reciprocal wavelength] menu

Shows the reflectance data corresponding to the case where wavelength is indicated in a reciprocal number. The graph indicates $1/\text{Wavelength}$ [1/nm] on the abscissa, and reflectance [%] on the ordinate.

6.8. [Graph setting] menu

The **[Graph setting]** menu displays the **[Graph setting]** window, where detailed settings for graphic indications of measured data are made. The settings are grouped by tabs. Make setting by selecting the intended tab.

6.8.1. [Theory] tab

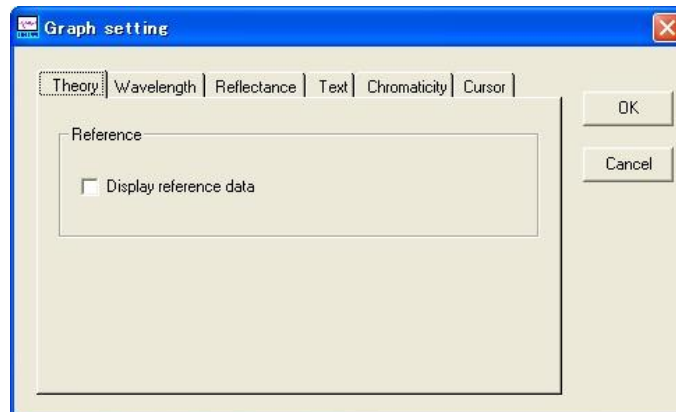

■ [Reference][Display reference data]

Shows the theoretical spectral reflectance data of a reflecting plane in a measured data graph in violet.

6.8.2. [Wavelength] tab

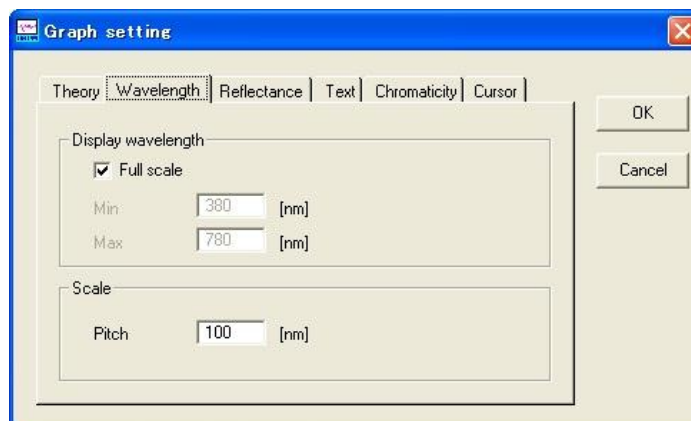

Specify here the indication wavelength range of measured data. The specified input range will have 380 [nm] as the minimum value on the short wavelength side, and 780 [nm] as the maximum value on the long wavelength side, the minimum value of indication being 20 [nm].

Note: Even when the indication range width is altered, the spectral reflectance data actually measured will be 380 to 780 [nm], and this range will be stored in the memory.

- **[Display wavelength][Full scale]**

If **[Full scale]** is currently checked, the maximum indication range from 380 to 780 [nm] will be displayed in a graph, in disregard of the set values of **[Min]** and **[Max]**. (Range from 440 to 780 [nm] on a model with 440nm - 840nm).

- **[Display wavelength][Short Wavelength]**

Specify the short wavelength side of the indication range of measured data.

- **[Display wavelength][Long Wavelength]**

Specify the long wavelength side of the indication range of measured data.

- **[Scale][Pitch]**

Specify the spacing of graduations on the wavelength axis. The input range for this specification is from 5 to 1000 [nm], and the graduations will be shown at the spacing value entered.

6.8.3. [Reflectance] tab

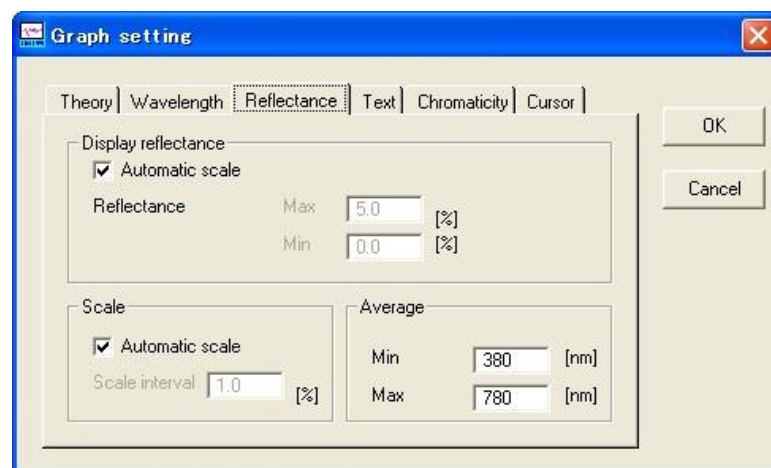

The indication reflectance scale of measured data is set here.

- **[Display reflectance][Automatic scale]**

If measurement is conducted with **[Automatic scale]** checked, the maximum reflectance will be set in such a manner that the whole measured data will be displayed in a graph. The unit is [%].

- **[Display reflectance][Max]**

Specify the maximum value for the reflectance scale. The range of this setting is from 0.01 to 100 [%].

- **[Display reflectance][Min]**

Specify the minimum value for the reflectance scale. The range of this setting is from 0.0 to 100 [%].

- **[Scale][Automatic Scale]**

Specify the automatic setup for reflectance graduations. If this is checked, an appropriate spacing of graduations for the scale width of reflectance will automatically be set up.

- **[Scale][Scale interval]**

Specify the spacing of graduations in the direction of reflectance. The maximum allowable number of graduations is [100].

- **[Average][Min]**

Specify the minimum value for the average reflectance range.

- **[Average][Max]**

Specify the maximum value for the average reflectance range.

* The scale of reflectance is converted and used as a graph scale of refractive index.

6.8.4. [Text] tab

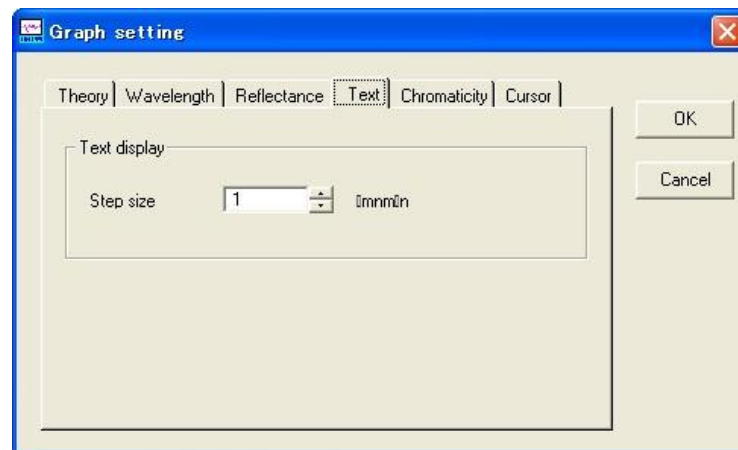

- **[Text display][Step size]**

Specify the step width for the indication wavelength in a text indication. This indication step is applied also when printing text data. The range of setting is from 1 to 100 [nm] steps.

6.8.5. [Chromaticity] tab (440nm - 840nm excluded)

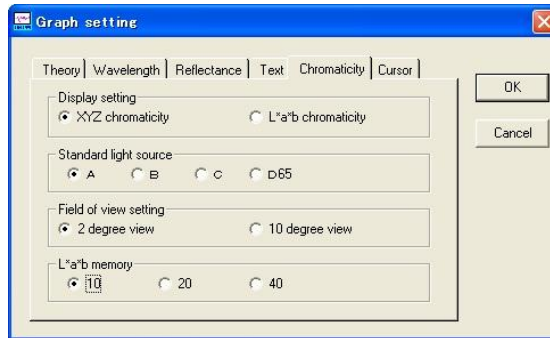

Make settings for an indication chromaticity diagram.

- **[Display setting][XYZ chromaticity][L*a*b chromaticity]**
Specify the chromaticity diagram to be displayed on the chromaticity diagram panel.
- **[Standard light source] [A] [B] [C] [D65]**
Specify the light source to be used in calculating chromaticity coordinates.
- **[Field of view setting] [2 degree view] [10 degree view]**
Specify the field to be used in calculating chromaticity coordinates.
- **[L*a*b memory]**
Set up memory for L*a*b chromaticity diagrams.

6.8.6. [Cursor] tab

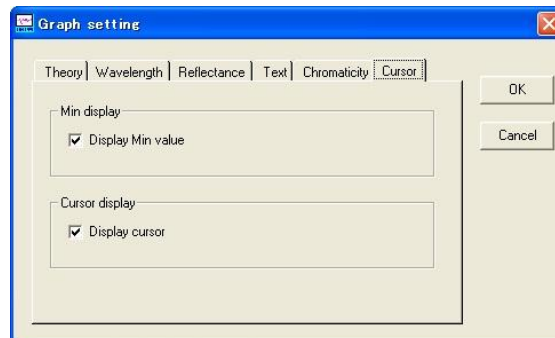

- **[Min display][Display Min value]**

If checked, this option automatically moves the cursor to the wavelength of the minimum reflectance among those measured.

- **[Cursor display][Display cursor]**

If checked, this option displays the cursor.

6.9. [Setting list] menu

Displays a listing of measurement setup parameters currently specified.

- **[Close]** button

Closes the **[USPM setting list]** window.

- **[Print]** button

Executes printing of the **[USPM setting list]** window. Make printer setup through **[Print Setup]** of the **[File]** menu.

6.10. [Additional Data] menu

Displays a test info input screen arbitrarily when saving data.

There, the test No., Notes 1, Notes 2, and measurement date can be entered for each one of **[DATA1]** to **[DATA10]**. The test No. should be entered in not more than eight characters. When measured data is saved on DAT format, notes1 of data1 is used.

■ **[OK]** button

Saves specified data and closes the window.

■ **[Cancel]** button

Cancels specified data and closes the window.

7. Details of [Standard] Menu

USPM-RU compares measured data to the preset standard and judges whether the data meets it or not.

7.1. [Standard setting] menu

In the **[Standard setting]** menu, the standard for OK/NG judgment is set up, and the reference values are entered. When the window is closed with the **[OK]** button, the program judges whether the selected data meets the standard or not. NG is decided if the upper-limit standard value is exceeded or the lower-limit standard value is undercut. The status bar at the screen bottom shows the name of the standard file currently open.

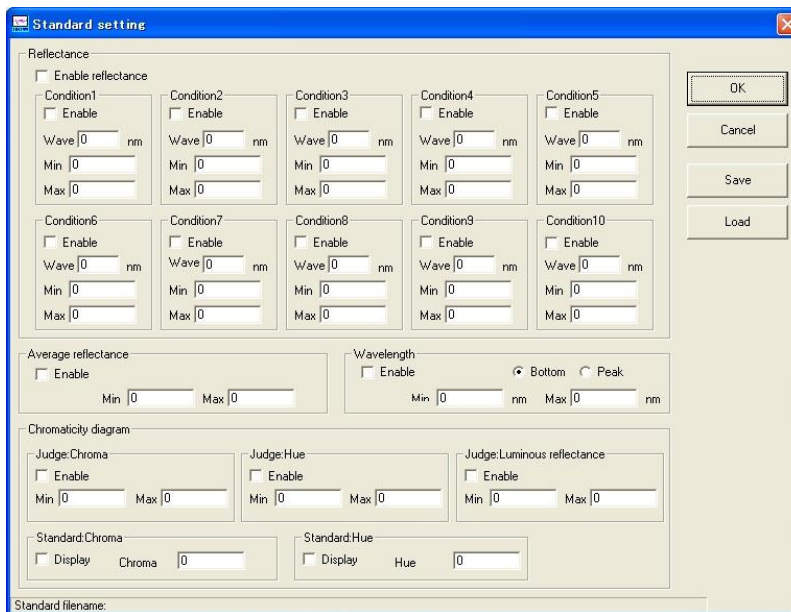

7.1.1. Reflectance

When the **[Enable reflectance]** check box is checked, the program decides OK or NG using the reflectance. Setting can be made in Condition 1 up to Condition 10, and the conditions currently checked only are valid. Key in the upper-limit value and lower-limit value. The result will be indicated as Reflectance: OK/NG in the status bar. Moreover, the standard line will be displayed on the Main Panel.

When the **[Enable]** check box in [Average reflectance] is checked, the program decides OK or NG using the mean reflectance. Key in the upper-limit value and lower-limit value. The result will be indicated as Rm: OK/NG in the status bar.

When the **[Enable]** check box in [Judge: Luminous reflectance] is checked, the program

decides OK or NG using the luminous reflectance. Key in the upper-limit value and lower-limit value. The result will be indicated as Rv: OK/NG in the status bar.

7.1.2. Chromaticity diagram (440nm - 840nm excluded)

When the **[Enable]** check box in [Judge: Chroma] is checked, the program decides OK or NG using the Chroma C*. Key in the upper-limit value and lower-limit value. The result will be indicated as C*: OK/NG in the status bar. Moreover, the standard line will be displayed in a yellow line on the chromaticity diagram.

When the **[Enable]** check box in [Judge: Hue] is checked, the program decides OK or NG using the hue angle key in the upper-limit value and lower-limit value. The result is indicated as hkkk: OK/NG in the status bar. Moreover, the standard line will be displayed in a yellow line on the chromaticity diagram.

[Standard: Chroma]

Check the [Display] check box, and enter the value. Then, the reference value will be displayed in a blue line.

[Standard: Hue]

Check the [Display] check box, and enter the value. Then, the reference value will be displayed in a blue line.

7.1.3. Wavelength value

When the **[Enable]** check box in [Wavelength] is checked, the program decides OK or NG using the wavelength value. Select either to use the peak or the bottom of the reflectance, and key in the upper-limit value and lower-limit value. The result will be indicated as Wavelength Value: OK/NG. Moreover, the standard line will be displayed on the chromaticity diagram.

7.2. How to save standards set up

Click **[Save]** to save standard values under an arbitrary file name.

Note: If the standards have been altered, make sure to save them, since the standard file name only is saved to an configuration file.

7.3. How to open stored standard values

Select **[Load]**, open the standard value data file, and make setting. The name of the file currently opened is displayed in the status bar of the standard setup window.

● Examples

Ex1) Standard setting of reflectance

Check **enable** on reflectance is and **enable** on condition 1 to 3. Then set the Condition 1 to 3 to next values.

	wave	min	Max
Condition 1	400 [nm]	4.2 [%]	4.6 [%]
Condition 2	500 [nm]	4.0 [%]	4.4 [%]
Condition 3	600 [nm]	4.0 [%]	4.4 [%]

Black lines represent reflectance of standard. Blue line represents measurement data. OK/NG is displayed in the red circle.

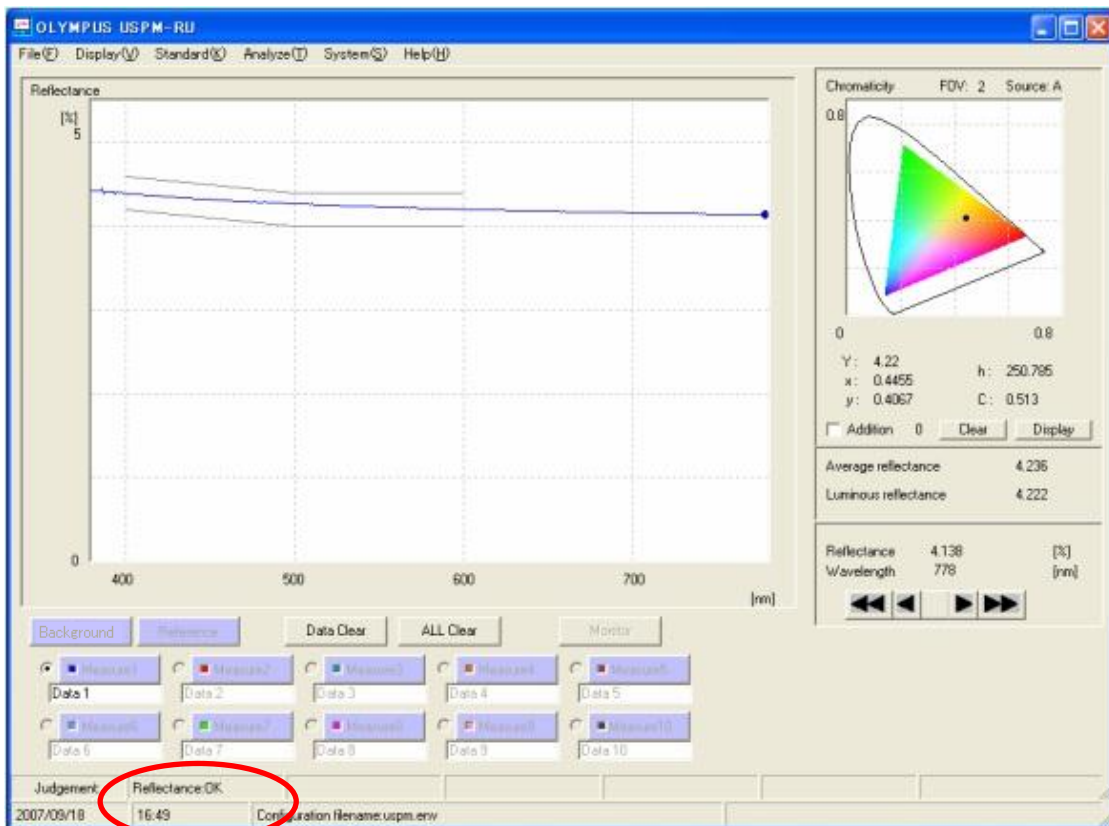

Ex2) Standard setting of chromaticity diagram

Check **enable** on chroma and hue . Then set the chroma and hue to next values.

	Min	Max
Chroma	30	40
Hue	180	240

Yellow lines represent reflectance of standard. Blue circle represents measurement data. OK/NG is displayed in the red circle.

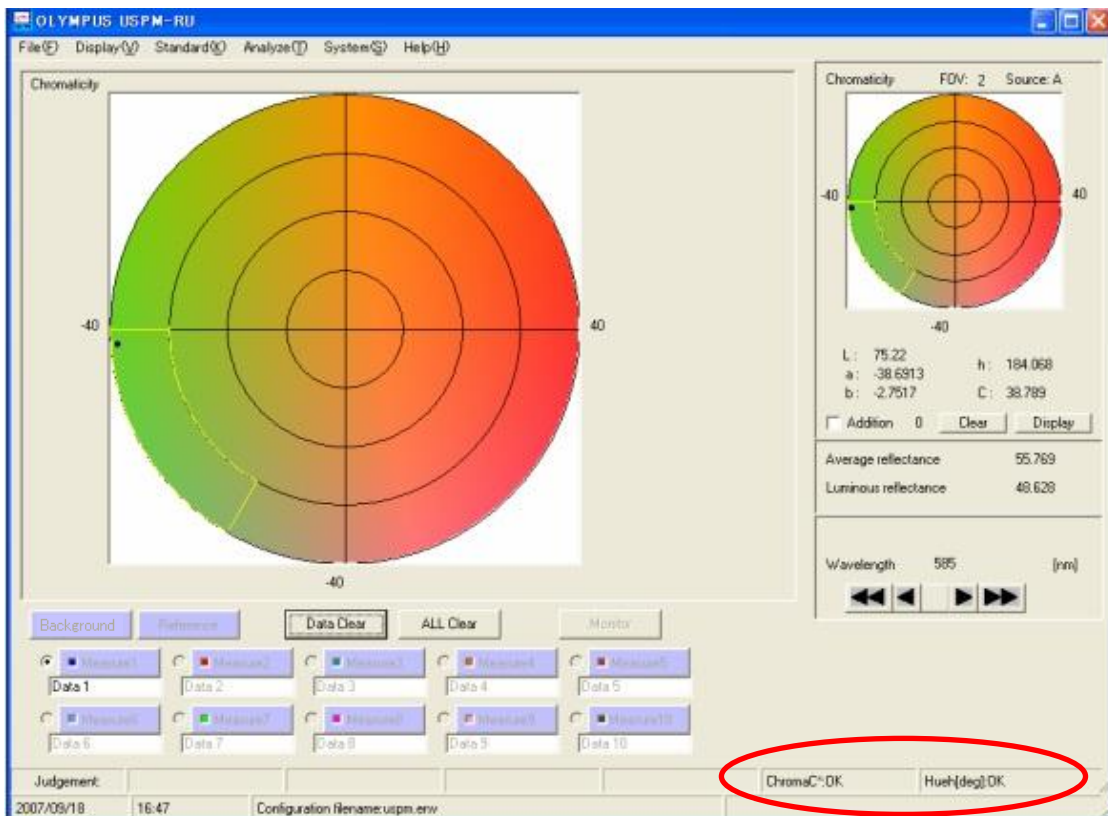

8. Details of [Analyze] Menu

8.1. [Film thickness setting] menu

Under this menu, the **[Film thickness setting]** window is displayed, and various types of parameters for monolayer film thickness measurements are set up.

8.1.1. [Measurement] tab

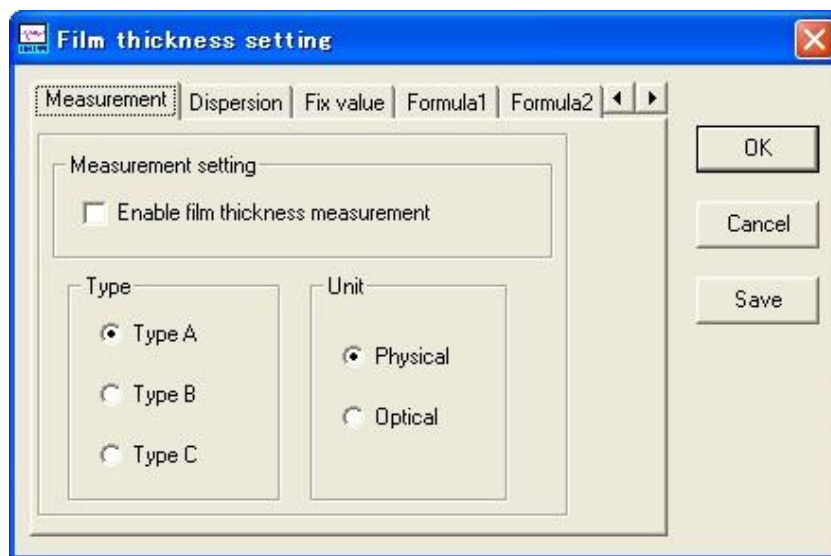

Basic parameters for a film thickness measurement are set up. Film thickness is calculated detecting the wavelengths of the peaks or valleys of spectral reflectance data. It is required that the wavelengths of two or more peaks or valleys be covered within the measurement wavelength range (400 to 780 [nm]) for each type.

■ [Measurement][Enable film thickness measurement]

Checking this option enables the thickness measurement of a monolayer film. The Main Window displays the **[Thickness]** button and the film thickness panel.

■ [Type]

Specify the detection method for peak or valley wavelengths at which to measure the film thickness. The detection method can be chosen from the following three types:

• [Type A]

This method calculates a film thickness from the wavelengths of two adjacent peaks or valleys sought for from the long wavelength side.

* If [Use the board refractive index] is currently selected, the peaks or valleys will be selected automatically. In other cases, valleys will be selected.

- **[Type B]**

This method calculates a film thickness from the wavelengths of the two peaks or valleys most widely spaced within the measurement wavelength range.

* If [Use the board refractive index] is currently selected, the peaks or valleys will be selected automatically. In other cases, peaks will be selected.

- **[Type C]**

The method calculates a film thickness from the wavelengths of the peaks or valleys most widely spaced within the measurement wavelengths.

- **[Unit]**

The unit of film thickness calculation can be selected from the optical film thickness and physical film thickness.

- **Measurement equations**

- [Type A] - [Physical film thickness]

$$d = \frac{1}{2} \cdot \frac{\lambda_1 \cdot \lambda_2}{n_{(\lambda_1)} \cdot \lambda_2 - n_{(\lambda_2)} \cdot \lambda_1}$$

d : Physical film thickness [nm]

λ_1 : Wavelength of the detected peak or valley (Short wavelength side)

λ_2 : Wavelength of the detected peak or valley (Long wavelength side)

$n_{(\lambda)}$: Dispersion of the refractivity wavelength of the coating material

- [Type A] - [Optical film thickness]

$$nd = \frac{1}{2} \cdot \frac{\lambda_1 \cdot \lambda_2}{\lambda_2 - \lambda_1}$$

nd : Optical film thickness [nd]

λ_1 : Wavelength of the detected peak or valley (Short wavelength side)

λ_2 : Wavelength of the detected peak or valley (Long wavelength side)

- [Type B] - [Physical film thickness]

$$d = \frac{N-1}{2} \cdot \frac{\lambda_1 \cdot \lambda_2}{n_{(\lambda_1)} \cdot \lambda_2 - n_{(\lambda_2)} \cdot \lambda_1}$$

- N : Number of the peaks or valleys detected between λ_1, λ_2 inclusive
d : Physical film thickness [nm]
 λ_1 : Wavelength of the detected peak or valley (Short wavelength side)
 λ_2 : Wavelength of the detected peak or valley (Long wavelength side)
 $n_{(\lambda)}$: Dispersion of the refractivity wavelength of the coating material

- [Type B] - [Optical film thickness]

$$nd = \frac{N-1}{2} \cdot \frac{\lambda_1 \cdot \lambda_2}{(\lambda_2 - \lambda_1)}$$

- N : Number of the peaks or valleys detected between λ_1, λ_2 inclusive.
nd : Optical film thickness [nd]
 λ_1 : Wavelength of the detected peak or valley (Short wavelength side)
 λ_2 : Wavelength of the detected peak or valley (Long wavelength side)

- [Type C] - [Physical film thickness]

$$d = \frac{N-1}{4} \cdot \frac{\lambda_1 \cdot \lambda_2}{n_{(\lambda_1)} \cdot \lambda_2 - n_{(\lambda_2)} \cdot \lambda_1}$$

- N : Number of the peaks and valleys detected between λ_1, λ_2 inclusive.
d : Physical film thickness [nm]
 λ_1 : Wavelength of the detected peak or valley (Short wavelength side)
 λ_2 : Wavelength of the detected peak or valley (Long wavelength side)
 $n_{(\lambda)}$: Dispersion of the refractivity wavelength of the coating material

- [Type C] - [Optical film thickness]

$$nd = \frac{N-1}{4} \cdot \frac{\lambda_1 \cdot \lambda_2}{\lambda_2 - \lambda_1}$$

- N : Number of the peaks and valleys detected between λ_1, λ_2 inclusive.
nd : Optical film thickness [nd]
 λ_1 : Wavelength of the detected peak or valley (Short wavelength side)
 λ_2 : Wavelength of the detected peak or valley (Long wavelength side)

8.1.2. [Dispersion] tab

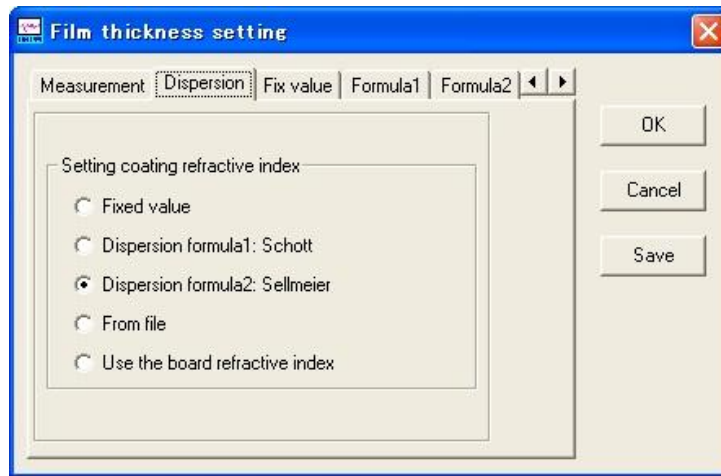

Specify the refractive index of the coat to be used for film thickness calculation.

■ [Setting coating refractive index]

● [Fixed Value]

If [Fixed Value] is currently selected, the refractive index set at the [Fix Value] tab will be employed as that of the coat for film thickness calculation.

● [Dispersion formula 1: Schott]

If [Dispersion formula 1: Schott] is currently selected, the refractive index set at the [Formula1] tab will be employed as that of the coat for film thickness calculation.

● [Dispersion formula 2: Sellmeier]

If [Dispersion formula 2: Sellmeier] is currently selected, the refractive index set at the [Formula2] tab will be employed as that of the coat for film thickness calculation.

● [From file]

If [From file] is currently selected, the file data set at the [File] tab will be employed as that of the coat for film thickness calculation.

- **[Use the board refractive index]**

If **[Use the board refractive index]** is currently selected, the file data (Reflectance data of board: *. csv) set at the **[board]** tab, the wavelengths of the peaks or valleys of coat + board reflectance, and the reflectances at those wavelengths will be employed as the coat refractive index for film thickness calculation. (*: An arbitrary file name)

$$n_c = \sqrt{\frac{1 + \sqrt{R}}{1 - \sqrt{R}}} \cdot n_b \cdots (8-1)$$

n_c : Coat refractive index
 n_b : Board refractive index
 R : Spectral reflectance in coated state

When $n_c < n_b$, use R_{\min} (Valley) for R , and when $n_c > n_b$, use R_{\max} (Peak) for R .

The refractive index of the coat is calculated by the above equation.

8.1.3. **[Fix value] tab**

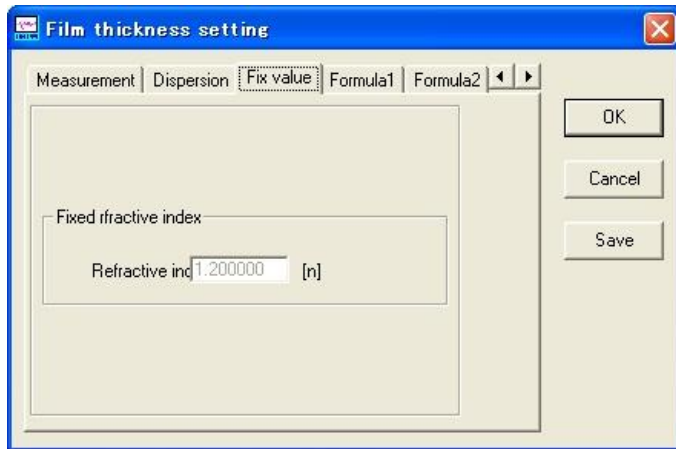

As the refractive index of the coating material to be measured, set a given refractive index (fixed value) that does not take into account wavelength dispersion.

8.1.4. [Formula1] tab

Schott's dispersion parameter	
A0	2.27025660E+00
A1	-9.19881010E-03
A2	1.16097060E-02
A3	-7.61239110E-05
A4	2.85587270E-05
A5	-1.25664860E-06

The refractive index of the coating material to be measured is employed in a dispersion equation that uses the parameters of A0 to A5. Equation (9-1), which is used in **[System]**, is employed as the dispersion equation.

8.1.5. [Formula2] tab

Sellmeier's dispersion parameter	
A1	1.15150190E+00
A2	1.18583612E-01
A3	1.26301359E+00
B1	1.05984130E-02
B2	-1.18225190E-02
B3	1.29617662E+02

The refractive index of the coating material to be measured is set in Sellmeier dispersion equation. Equation (9-2), which is used in **[System]**, is employed.

8.1.6. [File] tab

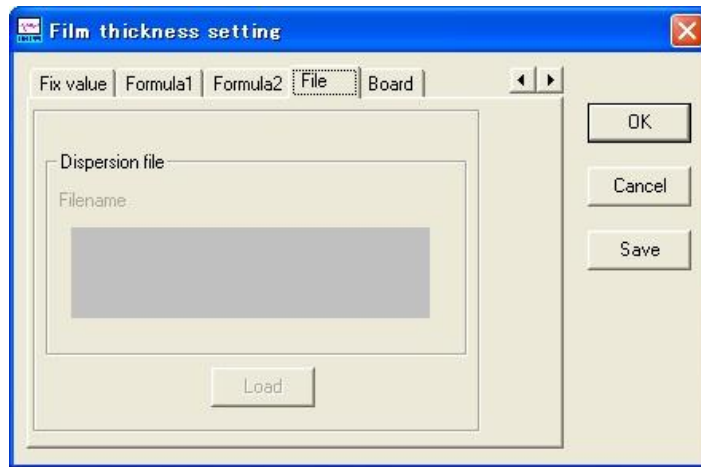

Specify the file of the refractive index of the coating material. The file will be that of the refractive index of 380 to 780 [nm] in steps of one [nm] in text format.

Reference: For details on the file format, see "12. File Configuration" described further ahead.

8.1.7. [Board] tab

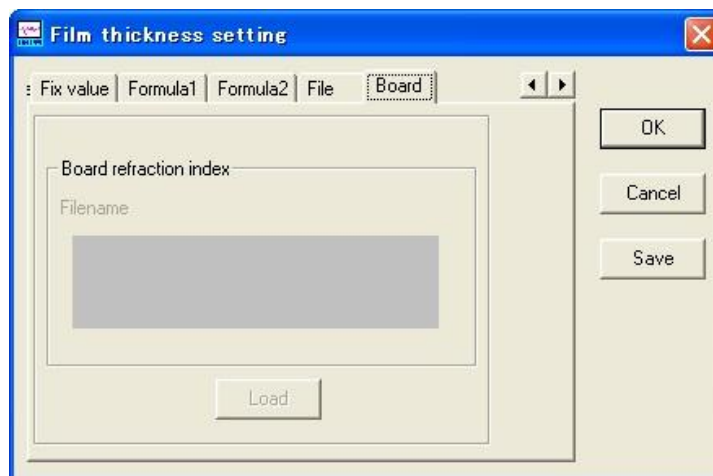

Specify the board reflectance. The refractive index (n_c in Equation 8-1) of the coat at the peak or valley wavelength is sought from the data (n_b in Equation 8-1) obtained by converting the loaded board reflectance into a refractive index and the reflectance (R in Equation 8-1) of the coated state. The file format will be that of the reflectance data (*.csv). (*: An arbitrary file name). However, the measured data of [Data1 Measured value of wavelength*] (*: An arbitrary wavelength) among the reflectance data is used as the board reflectance data.

Reference: For details on the file format, see "12. File Configuration" described further ahead.

8.1.8. [Save] button

Saves the coat reflectivity currently set in the window to a file. For instance, if a fixed value setting is specified and its value is 1.2 [n], the refractive index data of 1.2 [n] at 380 to 780 [nm] will be saved in the specified file name.

For details on the file format, see "12. File Configuration" described further ahead. Moreover, the data specified in the dispersion equation can also be saved to a file operating the **[Save]** button in the window.

Note: The button will be inactive when [Use the board refractive index] is currently selected.

8.2. [Wavelength list] menu

Displays the **[Wavelength list]** window and shows the wavelengths of the peaks and valleys detected in film thickness measurements.

8.2.1. [Wavelength list] window

Displays the wavelengths of the peaks (crest side) or valleys (trough side) in the list box.

- 1st column
Indicates the sequential order of the peaks or valleys detected. The detection takes place from 400 [nm] up to 780 [nm] on the short wavelength side.
- 2nd column
Indicates, by P/V, whether the displayed wavelength is a peak wavelength or valley wavelength.
- 3rd column
Indicates a peak wavelength or valley wavelength, in [nm].
- 4th column
Indicates the reflectance at the detected wavelength, in [%].

8.2.2. [Print] button

Prints the wavelength list currently displayed. Set up the printer through **[Print Setup]** of the **[File]** menu.

8.3. [Film thickness graph] menu

Opens the **[Film thickness graph]** window, and shows the measurement result history of

film thickness measurements in a graph. This graph is displayed as graph data when the displayed values of film thickness measurement results are pressed with the [Add] button. The data can be added up to a maximum of 50 points.

8.3.1. [File][Save as] menu

Saves the graph data to the film thickness history data file.

8.3.2. [File][All Clear] menu

Clears all the graph data. When the menu is selected, a confirmation message for the clearing appears. Pressing the **[OK]** button there executes the clearing of all data. Pressing the **[Cancel]** button cancels the clearing.

8.3.3. [Set][Graph setting] menu

Displays the **[Film Thickness Graph Setup]** window, where settings for graph indication are made.

■ **[Automatic scale]**

If this option is currently checked, the software will execute automatic scale setting in the direction of film thickness of a film thickness graph. Every time data is added or deleted, an appropriate maximum scale is set up, so that the data is displayed over the entire graph. The values specified in **[Min]** and **[Max]** are not used, and the minimum scale value is always 0 [nm].

■ **[Min]**

Set the minimum scale value in the direction of film thickness of a film thickness graph scale. If **[Automatic scale]** is currently specified, this set value will not be used. The range for this setting is from 0 to 20000, and a difference of 100 or more from **[Max]** is required.

■ **[Max]**

Set the maximum scale value in the direction of film thickness of a film thickness graph scale. If **[Automatic scale]** is currently specified, this set value will not be used. The range for this setting is from 0 to 20000, and a difference of 100 or more from **[Min]** is required.

8.3.4. [Data information]

■ Indication of **[Points]**

Shows the total number of data present on the graph. The maximum number of data is 50 points.

■ Indication of **[Thickness]**

The measurement unit ("[nm]"/"[nd]") is [nm] if physical film thickness was selected at **[Unit]** of the **[Film thickness measurement]**, or [nd] if optical film thickness was chosen. Since the measurement unit ruling when the film thickness graph window was displayed is reflected, be aware that the measurement unit on the Main Window side will not be reflected when this window stays open. Also for the unit of the film thickness history data file, the unit indicated on this panel at the time of saving data will be saved.

Shows the film thickness of the measured data where the cursor is located.

■ Indication of **[Data Index]**

Shows the number of the measurement data where the cursor is located. The data first added to the graph is assigned the number 1.

■ **[Add]** button

Adds measured film thickness data to a graph. It adds, as the newest data of the graph, the value currently displayed when the film thickness measurement is valid (the film thickness panel is displayed) and a film thickness is being measured.

■ **[Delete]** button

Deletes the measured data where the cursor is currently located.

■ **[Close]** button

Closes the window. Even when the window is closed, the graph data is saved till the program is deactivated.

■ **[<][>]** buttons

Move the cursor over a graph.

8.4. [Color difference] menu

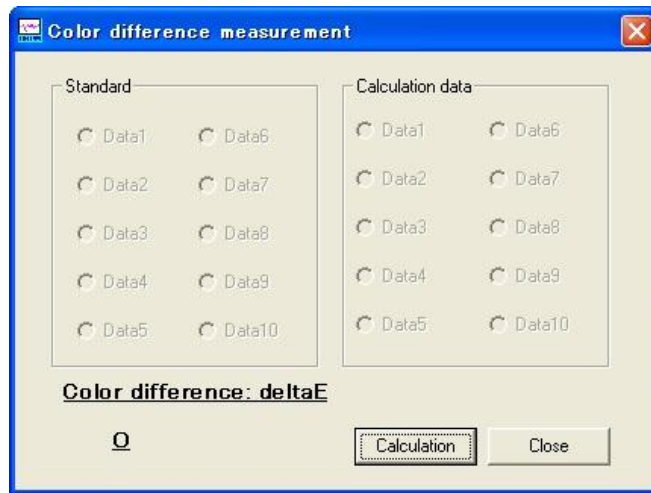

Opens the [Color difference measurement] window, calculates and indicates color difference ΔE .

Select any two data points and press the [Calculation] button. The result will be displayed. The color difference is calculated by this equation.

$$\Delta E = \sqrt{\Delta L^{*2} + \Delta a^{*2} + \Delta b^{*2}}$$

ΔL^* : The difference of L^* in L^*a^*b diagram

Δa^* : The difference of a^* in L^*a^*b diagram

Δb^* : The difference of b^* in L^*a^*b diagram

9. Details of [System] Menu

The basic equation for seeking spectral reflectances using the USPM-RU is indicated further below. The spectral reflectance of a sample is calculated with reference to the known reflecting plane of the reference, and based on the spectral reflection intensity of the reference, spectral reflection intensity of the sample, and spectral intensity of the background.

$$R_{(\lambda)} = \frac{I_{sample(\lambda)} - I_{background(\lambda)}}{I_{reference(\lambda)} - I_{background(\lambda)}} \cdot R_{theory(\lambda)}$$

$R_{(\lambda)}$: Measured spectral reflectance data

$I_{sample(\lambda)}$: Spectral reflection intensity of the sample

$I_{reference(\lambda)}$: Spectral reflection intensity of the reference

$I_{background(\lambda)}$: Spectral reflection intensity of the background

$R_{theory(\lambda)}$: Theoretical spectral reflectance data of the reference

9.1. [Reference Setting] menu

Displays the **[Reference setting]** window, where the theoretical reflectance of the reference to be used in calculating spectral reflectances is specified.

9.1.1. [Dispersion] tab

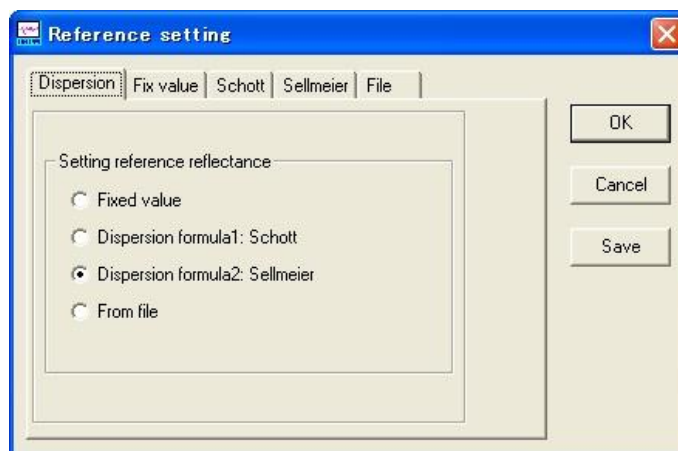

Specify the data to be used for calculating the theoretical reflectance of the reference. Specify any

of fixed values, Schott, Sellmeier, or a file. When the window is closed by pressing **[OK]** after the setup, the data set here will be applied to the calculation.

Note: When a file has been specified, open the file by the **[File]** tab.

9.1.2. [Fix value] tab

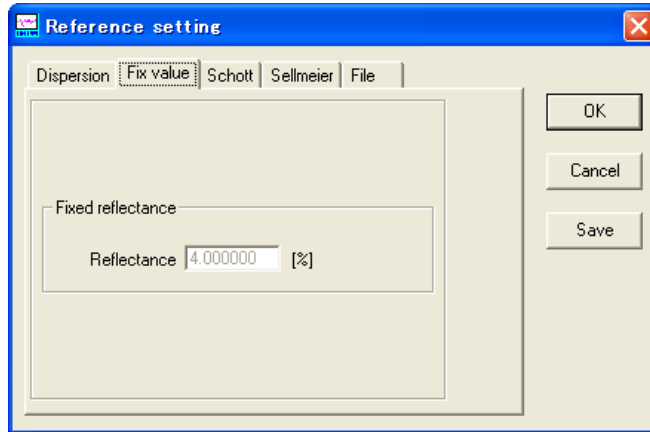

Use a fixed value that does not take into account wavelength dispersion as the theoretical spectral reflectance of the reference. The numeric value (reflectance) specified here will be set as the reflectance at all the measured wavelengths.

9.1.3. [Schott] tab

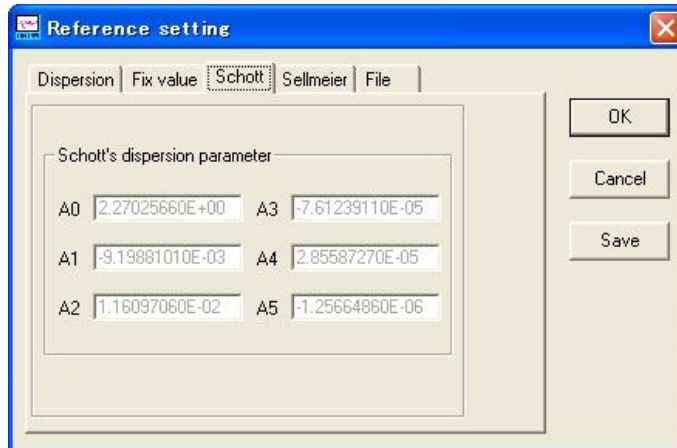

Set wavelength dispersion using the parameters from A0 to A5. Each parameter can be taken from the catalogs of materials, etc. The theoretical reflectance of the reference is set as the reflectance of each wavelength, based on those parameters, and will be used in calculating the spectral reflectances of samples.

$$n_{(\lambda)} = \sqrt{A_0 + A_1 \cdot \lambda^2 + A_2 \cdot \lambda^{-2} + A_3 \cdot \lambda^{-4} + A_4 \cdot \lambda^{-6} + A_5 \cdot \lambda^{-8}} \quad \text{Equation (9-1)}$$

$$R_{theory}(\lambda) = \left(\frac{1 - n_{(\lambda)}}{1 + n_{(\lambda)}} \right)^2$$

$n_{(\lambda)}$: Wavelength dispersion of refractive index

$A_0 \dots A_5$: Parameters of the dispersion equation

$R_{theory}(\lambda)$: Wavelength dispersion of the reference reflectance

9.1.4. [Sellmeier] tab

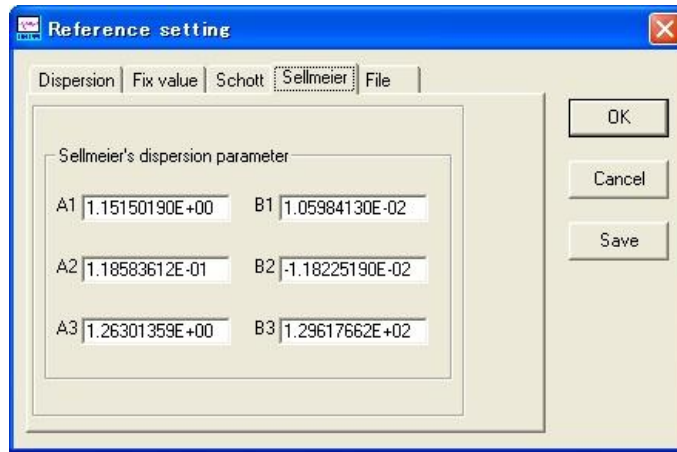

Set the theoretical spectral reflectance data of the reference using Sellmeier dispersion equation.

$$n_{(\lambda)}^2 - 1 = \frac{A_1 \lambda^2}{\lambda^2 - B_1} + \frac{A_2 \lambda^2}{\lambda^2 - B_2} + \frac{A_3 \lambda^2}{\lambda^2 - B_3} \quad \text{Equation (9-2)}$$

$$R_{(\lambda)} = \left(\frac{1 - n_{(\lambda)}}{1 + n_{(\lambda)}} \right)^2$$

$n_{(\lambda)}$: Wavelength dispersion of refractive index

$A_1 \dots A_3, B_1 \dots B_3$: Parameters of the dispersion equation

$R_{(\lambda)}$: Reference

9.1.5. [File] tab

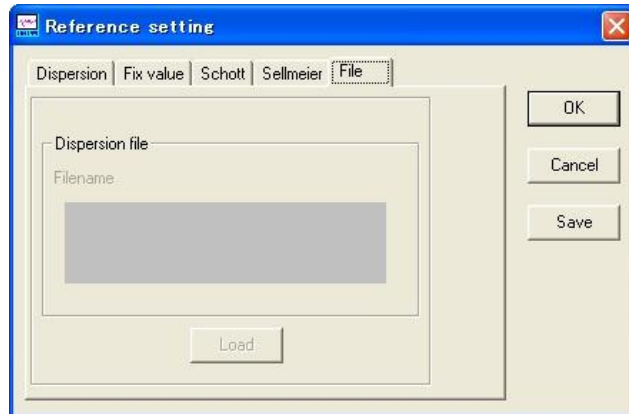

Specify a file data as the theoretical spectral reflectance of the reference. The file data will be a reflectance in text format in steps of one [nm]. This allows that spectral reflectance data measured with another spectrometer, etc., be used as the theoretical spectral reflectance data of the reference.

9.1.6. [Save] button

Saves the theoretical reflectance of the reference currently specified in the window to a file. For instance, if a fixed value setting is currently specified and its value is 4.0 [%], the theoretical spectral reflectance data of 4.0 [%] at all the measured wavelengths will be saved in the specified file name.

Note: For details on the file format, see "12. File Configuration" described further ahead.

9.2. [Sampling] menu

Opens the **[Sampling setting]** window, where the basic parameters of the USPM spectrometer are specified. Make setting for the quantity of light reading of the line sensor employed in the USPM spectrometer. Quantity of light I read by the line sensor is represented by the following equation:

$$I = \sum^{\text{Number of samplings}} (\text{Quantity of light} \times \text{Sampling time})$$

The quantity of light of the line sensor is subjected to 12-bit A/D conversion. Therefore, if the quantity of light sampled in one single sampling exceeds 12 bits (actually 4080), saturation will occur, making it impossible to measure accurate values.

Note: If parameters have been set here, be sure to measure the background and reference once again.

■ [Sampling][Sampling time]



Specify a sampling time in [mSec]. The range for this setting is from 30 to 10000 [mSec]. Set an appropriate time for each sample, so that the reflectance of the reflecting plane of the reference or that of the sample, whichever is higher, assumes a value on the order of 70% to 80% of the maximum value of 4080. This will provide stable measurement results.

9.3. [Calibration] menu

The calibration value in the wavelength direction of the USPM spectrometer is set. The set value here is designed for the software to shift displacements in the wavelength direction of the spectrometer within a range of ± 4 [nm].

10. [Help] Menu

10.1. [Version] menu



Displays the version.

11. About the Calibration Method for Wavelength Direction

11.1. General description of calibration

The calibration of the wavelength direction refers to the setting that is made to display the spectral reflectance data measured with USPM in a correct position by means of a sample whose spectral reflectance peak is known (measured with other calibrator, etc.). The calibration shifts, by ± 4 [nm], the entire measured wavelengths toward the short wavelength side or long wavelength side of the wavelength direction.

11.2. Calibration procedure

This subsection explains the calibration conducted by using the wavelength calibration sample supplied standard with the software. The accessory calibration sample will be measured here.

■ Preparation

Put the calibration sample on the table. Bring the calibration sample to which a transparent glass is bonded into focus. Operate the microscope in such a manner that the bonded reflecting mirror face, not the transparent glass face, will be brought into focus.

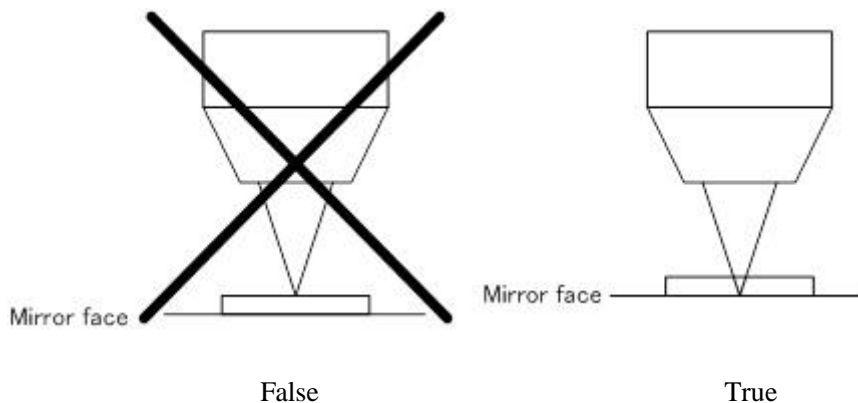

■ Measurement of background

Measure the background as in an ordinary measurement.

■ Measurement of reference

Measure the plane of the calibration sample to which a transparent glass is bonded as the reflecting plane of the reference. If the data is found saturated when the reference is measured, adjust the sampling time.

- Measurement of sample

Bring the calibration sample face that looks blue into focus on the reflecting mirror face, as in the case of the reference, and then, measure the sample.

- Calibration of wavelength

Display the **[Calibration]** window through the **[System][Calibration]** menu, and enter **[Shift Value]**. If **[Shift Value]** is selected large, the measured data will shift toward the long wavelength side, in steps of one [nm]. Set **[Shift Value]** at which the known peak of the calibration sample best matches the peak wavelength of the “Calibration Sample Reflectance Graph” (P50).

- Saving of shift value

Pressing the **[OK]** button in the **[Calibration]** window saves **[Shift Value]**. When this file is loaded at the time of the next startup, the calibration value can be set up. For details on the file format, see "12. File Configuration" described further ahead.

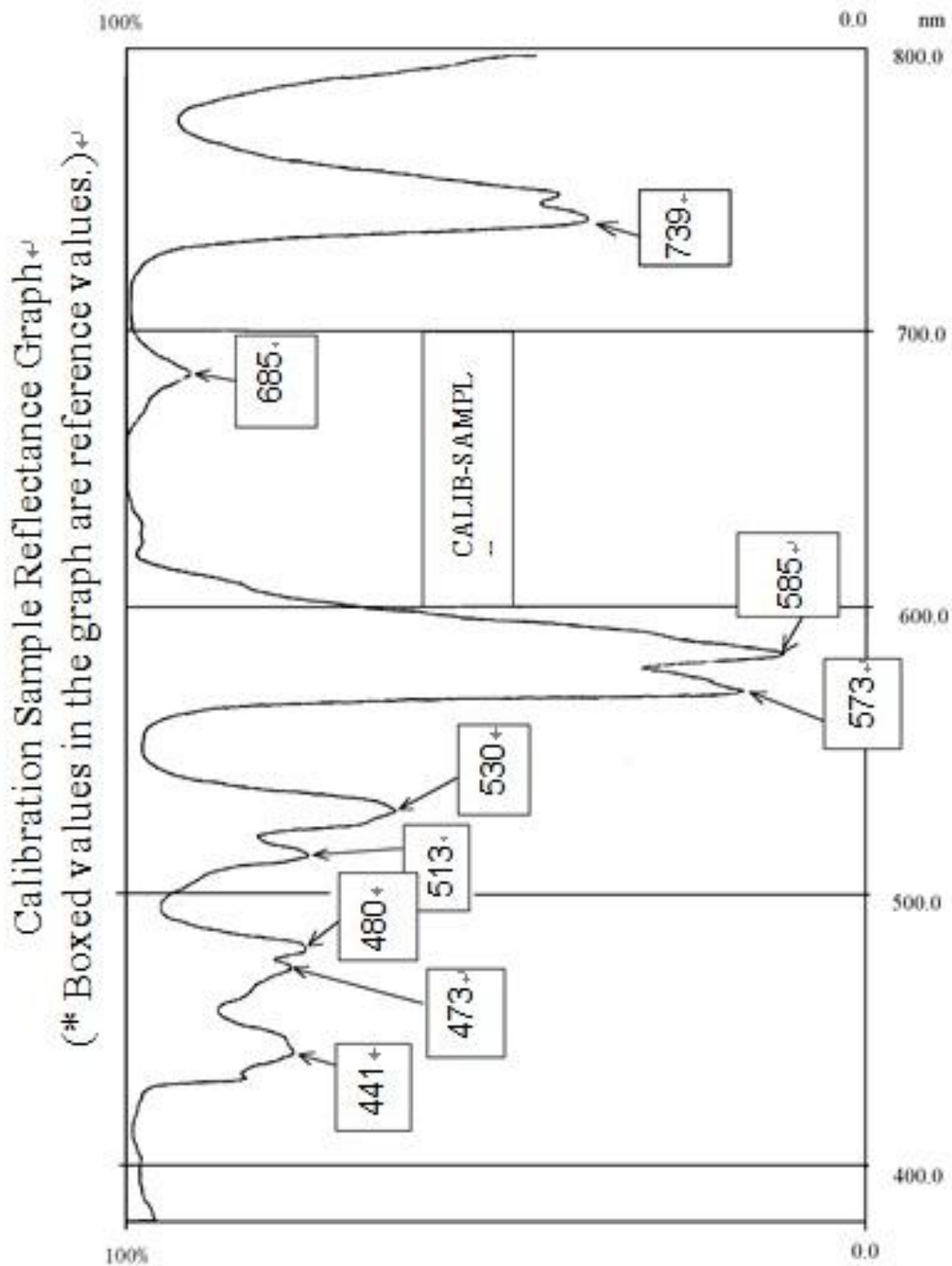

12. File Configuration

USPM-RU uses the following files on the program.

12.1. Startup file (uspm.int)

This file is loaded at the time USPM-RU is launched, and is named "uspm.int". This file stores the name of the configuration file which was in use when USPM was last closed. When the stored configuration file is loaded again, the program can be started up in the same environment. If the loading of the startup file fails, an error message will be displayed, and the measurement setup parameters will take the default values (set in the system program).

```
Data file ID tag
Configuration file name (*.env) (*: An arbitrary file name)
Port No.
Wavelength calibration value 1
Wavelength calibration value 2
Wavelength calibration value 3
Wavelength calibration value 4
Wavelength calibration value 5
Wavelength calibration value 6 (440nm - 840nm excluded)
Waiting time of shutter
[end]
```

12.2. Calibration file (uspm.cal)

This data file stores the indication calibration values in the wavelength direction of USPM. The file is always loaded at the time the program is launched, and the spectral reflectance is indicated in accordance with that data. If an error occurs during the file load, Default Value 4 will be set.

12.3. Configuration File (*.env)

This file stores the measurement setup parameters of USPM-RU, its extension being "*.env". When configuration files are individually created for different samples, it is possible to set up measurement environments by loading the files. The file-related data includes the following:

- Name of coating material spectral dispersion data file (*.ind)
- Spectral dispersion data file of the reference (*.ref)

- Standard data file(*.std)

If the following file names are specified, the program loads those files after the configuration file is loaded. Files in different versions or those with different wavelength regions cannot be loaded. (*: An arbitrary file name)

Data file ID tag
Main panel indication type
Reference data display/non-display
Wavelength full-scale flag
Wavelength short wavelength value
Wavelength long wavelength value
Wavelength graduation spacing
Reflectance auto-scale setting flag
Max. reflectance value
Min. reflectance value
Automatic reflectance graduation spacing flag
Reflectance graduation value
Number of text indication steps
Chromaticity diagram type L*a*b*/xyz
Standard light source
Field
L*a*b scale type
Cursor indication position flag (Reflectance Min)
Cursor indication flag
Standard file name
Reference dispersion equation type
Fixed reference value
Schott's parameter A0
Schott's parameter A1
Schott's parameter A2
Schott's parameter A3
Schott's parameter A4
Schott's parameter A5
Sellmeier's parameter A1
Sellmeier's parameter A2
Sellmeier's parameter A3
Sellmeier's parameter B1
Sellmeier's parameter B2
Sellmeier's parameter B3

Reference file name
Sampling time
Film thickness measurement-ready flag
Measurement type
Unit type
Dispersion equation type
Fixed value
Schott's parameter A0 for film thickness
Schott's parameter A1 for film thickness
Schott's parameter A2 for film thickness
Schott's parameter A3 for film thickness
Schott's parameter A4 for film thickness
Schott's parameter A5 for film thickness
Sellmeier's parameter A1 for film thickness
Sellmeier's parameter A2 for film thickness
Sellmeier's parameter A3 for film thickness
Sellmeier's parameter B1 for film thickness
Sellmeier's parameter B2 for film thickness
Sellmeier's parameter B3 for film thickness
File name for film thickness
Refractive index data file name
[end]

12.4. Spectral reflectance data file (*.csv)

This file stores the spectral reflectance data measured with USPM. USPM-RU is capable of indicating up to 10 points of measured data simultaneously, and saving those data to the same file. When loading the file, the software reproduces the indications as at the time of saving.

The data file is saved in the CSV format or DAT format.

The CSV format

```

USPM-RU Ver3.21 Data File      : Data file ID tag
wave, DATA1, Data2, ... , Data10 : Data name
wavelength380, Data1 Measured value at wavelength 380, Data2 Measured value at wavelength 380,
--- Data10 Measured value at wavelength 380

wavelength381, Data1 Measured value at wavelength 381, Data2 Measured value at wavelength 381,
--- Data10 Measured value at wavelength 381

wavelength382, Data1 Measured value at wavelength 382, Data2 Measured value at wavelength 382,
--- Data10 Measured value at wavelength 382
...
wavelength778, Data1 Measured value at wavelength 778, Data2 Measured value at wavelength 778,
--- Data10 Measured value at wavelength 778

wavelength779, Data1 Measured value at wavelength 779, Data2 Measured value at wavelength 779,
--- Data10 Measured value at wavelength 779

wavelength780, Data1 Measured value at wavelength 780, Data2 Measured value at wavelength 780,
--- Data10 Measured value at wavelength 780

[end]

```

The DAT format

```

USPM-RU Ver3.20 Data File      : Data file ID tag
                               : Comment
                               : Number of data point

Data1                          : Data name
Data1 Measured value at wavelength 380
Data1 Measured value at wavelength 381
...
Data1 Measured value at wavelength 780
Data2                          : Data name
Data2 Measured value at wavelength 380
...
Data2 Measured value at wavelength 780
...
Data10                         : Data name
Data10 Measured value at wavelength 380
...
Data10 Measured value at wavelength 780

[end]

```

12.5. Additional data file (*add.csv)

When a file of a measurement conducted with USPM-RU is saved in the CSV format, an additional data file is created automatically. Its file name will be the reflectance data file name + add.csv. This file stores L^* , a^* , b^* , x^* , y^* , Y , hue angle, chroma, mean reflectance, luminous

reflectance, sample No., measuring position, measurer, coating device No., and measurement date.

```

USPM-RU Ver3.21 AddData File      : Data file ID tag
Item name, L* of Data1, L* of Data2, L* of Data3, ---
Item name, a* of Data1, a* of Data2, a* of Data3, ---
Item name, b* of Data1, b* of Data2, b* of Data3, ---
Item name, x of Data1, x of Data2, x of Data3, ---
Item name, y of Data1, y of Data2, y of Data3, ---
Item name, Y of Data1, Y of Data2, Y of Data3, ---
Item name, Hue angle of Data1, Hue angle of Data2, Hue angle of Data3, ---
Item name, Chroma of Data1, Chroma of Data2, Chroma of Data3, ---
Item name, Mean reflectance of Data1, Mean reflectance of Data2, Mean reflectance of Data3, ---
Item name, Luminous reflectance of Data1, Luminous reflectance of Data2, Luminous reflectance
of Data3, ---
Item name, Sample of Data1, Sample of Data2, Sample of Data3, ---
Item name, Remarks 1 of Data1, Remarks 1 of Data2, Remarks 1 of Data3, ---
Item name, Remarks 2 of Data1, Remarks 2 of Data2, Remarks 2 of Data3, ---
Item name, Measurement date of Data1, Measurement date of Data2, Measurement date of Data3,
---
[end]

```

12.6. Coating material wavelength dispersion data file (*.ind)

This is the wavelength dispersion data file of coating material refractivities that is used in calculating film thicknesses, its extension being "*.ind". The data is in a text format, and the refractivities from 380 to 780 [nm] are arranged following the ID tag, in steps of one [nm].

```

USPM-RU Ver3.21 Index File      : Coat data file ID tag
1.0000000000000000             : Refractive index data [n](380[nm])
1.0000000000000000             : Refractive index data [n](381[nm])
...
1.0000000000000000             : Refractive index data [n](780[nm])
[end]

```

12.7. Reference wavelength dispersion data file (*.ref)

This file is employed when the reflectance data of the reference reflecting plane is designated in a file, its extension being "*.ref". The data is in a text format, and the refractivities from 380 to 780 [nm] are arranged following the ID tag, in steps of one [nm].

USPM-RU Ver3.21 Reference File	: Reference file ID tag
4.43729459935712	: Reflectance data [%] (380[nm])
4.43524682827653	: Reflectance data [%] (381[nm])
...	
4.14387764412366	: Reflectance data[%] (780[nm])
[end]	

12.8. Standard data file (*.std)

This is a file of OK/NG judgment standard data.

```
File ID tag
Flag for use of reflectance
Flag for use of Condition 1
Condition 1 wavelength
Condition 1 upper-limit value
Condition 1 lower-limit value
... (Up to Condition 10)
Flag for use of mean reflectance
Mean reflectance upper-limit value
Mean reflectance lower-limit value
Flag for use of luminous reflectance
Luminous reflectance upper-limit value
Luminous reflectance lower-limit value
Flag for use of wavelength value
Bottom and peak flags
Wavelength upper-limit value
Wavelength lower-limit value
Flag for use of chroma
Chroma upper-limit value
Chroma lower-limit value
Flag for use of hue angle
Hue angle upper-limit value
Hue angle lower-limit value
[end]
```

12.9. Film thickness history data file (*.thk)

The file stores the history data of film thickness measurements that are saved through the **[Film thickness graph]** window. Its extension is "*.thk". Its file format is shown below.

USPM-RU Ver3.21 Thickness File	: Film thickness data file ID tag
50	: Total data count
"[nm]"	: Unit "[nm]"/"[nd]"
1000.0000	: 1st measured film thickness
1000.0000	: 2nd measured film thickness
1000.0000	: 3rd measured film thickness
...	
1000.0000	: Last measured film thickness
[end]	

12.10. Cumulative chromaticity diagram data (*.dat)

This is the cumulative chromaticity diagram data saved through the chromaticity diagram window.

The file stores a maximum of 100 data points.

USPM-RU Ver3.21 Stock File	: ID tag
True	: Stored chromaticity diagram type flag
1	: Standard light source
True	: Field
3	: Data count
1.000000,1.000000,1.000000	: Cumulative measured chromaticity data 1
1.000000,1.000000,1.000000	: Cumulative measured chromaticity data 2
1.000000,1.000000,1.000000	: Cumulative measured chromaticity data 3
[end]	

13. About the Alarm and Error Indications

13.1. Errors related to communications

■ **“An error occurred while initializing GP-IB”**

The initialization of the PC card for GP-IB communication failed. Check to see if the card is securely inserted into the slot. The program can be started up despite the occurrence of the error, but no measurement can be conducted.

■ **“GP-IB communication timeout error”**

An error occurred in the GP-IB communication. Make certain that the power of the control box is turned on, and that the GP-IB cables are properly connected, and then, restart the program. The program can be started up despite the occurrence of the error, but no measurement can be conducted.

■ **“Communication error”**

An error occurred in the USB communication or GP-IB communication. Make certain that the power of the control box is turned on, and the GP-IB cables are properly connected, and then, restart the program. The program can be started up despite the occurrence of an error, but no measurement can be conducted.

13.2. Errors related to measurements

■ **“Please lower Light intensity”**

The measured data from the spectrometer is saturated, because the quantity of light is too intense. Shorten the sampling time, and make adjustment, so that appropriate data is obtained. Display a quantity of light graph, and operate the quantity of light monitoring button to view the data from the spectrometer.

■ **“Measure background”**

When measuring a sample (object under measurement), the background and reference must have priorly been measured, so that measured results can be calculated. Before measuring a sample, measure the background.

■ **“Measure reference”**

When measuring a sample (object under measurement), the background and reference must have priorly been measured, so that measured results can be calculated. Before measuring a sample, measure the reference.

■ **“The point was already measured. Do you want to measure again?”**



Notice that this previous data cannot be restored, if deleted.

The selected Measure button already has a measurement conducted and contains measured data. Click the [OK] button if you agree to overwrite it.

■ **“System has reached data limit of 100”**



Be aware that, if you conduct a next measurement without priorly clearing the accumulated data, the new measured data will not be accumulated.

When chromaticity diagrams are accumulated, this message announces that the cumulative count has reached 100. Accumulation cannot be made in excess of 100 data points.

■ **“System has reached data limit of 100. Please clear data”**

When measurement is conducted despite that the cumulative count has exceeded 100, this message will appear prompting you to clear the accumulated data. The data you measured just now is not accumulated. Clear the data and redo the measurement.

■ **“An error occurred while loading the startup file”**

The loading of the startup file (uspm.int) failed. The startup file may be broken or cannot be found. Check to see if the directory containing USPM-RU has been specified as the work directory for execution. (Check by the USPM-RU short-cut property.) Also, check to see if the startup file is located in the directory containing USPM-RU.

Since an error occurred in the loading of the startup file, the configuration file could not be loaded. Therefore, the default set values will be taken for the configuration settings.

■ **“An error occurred while creating the startup file”**

Write of the startup file (uspm.int) failed during closing of the program. Use the property to check to see if the startup file (uspm.int) is inhibited from being written. Since no configuration file name is saved at the closing, the environment as at the closing will not be reproduced at the restart.

■ **“An error occurred while loading the configuration file”**

Write of the configuration file (*.env) failed. The configuration file may be broken. Set parameters once again, or load an configuration file anew.

■ **“Configuration file version error”**

An attempt was made to load an configuration file (*.env.) in different version. Check the version. The configuration parameters will be set to the system default values.

■ **“An error occurred while creating the configuration file”**

Write of the configuration file (*.env) failed. The parameters will not be saved. Use the property to check to see if the specified configuration file is inhibited from being written.

■ **“An error occurred while loading the wavelength calibration file”**

Loading of the wavelength calibration file (uspm.cal) failed. The calibration value will be set to Default value 4. Execute calibration again in the wavelength direction. When calibration is conducted, the file will be automatically saved.

■ **“An error occurred while creating the wavelength calibration file”**

Write of the wavelength calibration file failed. Check to see if the calibration file (uspm.cal) is inhibited from being written. The calibration value will not be saved.

■ **“An error occurred while loading the standard file”**

Loading of the standard file (*.std) failed. Check to see if the specified directory contains the specified standard file. No standards will be set up.

■ **“An error occurred while creating the standard file”**

Check to see if the specified standard file (*.std) is inhibited from being written.

■ **“An error occurred while loading the reference file”**

Loading of the reference file (*.ref) failed. Set the reference data again through the [System][Reference Setup] menu.

■ **“An error occurred while creating the reference file”**

Check to see if the reference data (*.ref) is inhibited from being written, and if the specified directory exists.

■ **“An error occurred while loading the refraction index file”**

Loading of the refractive index file (*.ind) to be used in film thickness measured failed. Check to see if the specified refractive index file is contained in the specified directory. Set again the refractive index of the coating material.

■ **“An error occurred while creating the refraction index file”**

Write of the refractive index file (*.ind) failed. Check to see if the specified refractive index file is inhibited from being written.

■ **“The Refractive index file did not load”**

Even though [File Setup] was selected in the coat refractive index setup, the coat material refractive index data file (*.ind) has not been loaded. Specify the file at the [File] tab.

■ **“The refraction index data did not load”**

Even though "Calculate using board refractive index" was selected in the coat refractive index setup, the substrate data file (*.csv) has not been loaded. Specify the file at the [Board] tab.

13.3. Operational errors

■ **“An error occurred in the film thickness calculation because less than two points exist”**

Film thickness measurement is calculated based on the wavelengths of two detected peaks or valleys. When issued, this error means that there were not two or more peaks or valleys in the measurement range (400 to 780 [nm]).

■ **“Number of peaks detected exceeds the maximum number or detections allowed (The maximum number of peaks:50)”**

In a film thickness measurement, peaks or valleys are detected over the entire measurement range (400 to 780 [nm]). While the detection count varies with the type of measurement, a maximum of 50 is allowed, respectively, when peaks only, valleys only, or peaks and valleys are detected. If this number is surpassed, an error will be output.

The cause of this error is likely to reside in that the measured data of spectral reflectances is so unstable that minute noise is likely detected as a peak or valley. This situation will improve when the sampling time in the system setup is increased in order to suppress noise in the measured data.

■ **“An error occurred while calculating the film thickness”**

An error occurred in the calculation of film thicknesses. Check the settings of the coat material refractive index, etc.

13.4. Combination error

■ **“The combination of 'Type C' and 'Calculation using board refraction index' is not allowed”**

"Type C" cannot perform calculation using "Calculate using board refractive index". Check the settings of the measurement type.

14. Precautions

- This program is able to run on Windows XP/Vista/7. If any other software than the one initially installed is installed anew, such software may not operate normally. Olympus cannot hold itself liable for any operating problems that may arise in such case.
- This product is controlled under the "Export-related regulations for foreign exchange and foreign trade control." To export or take this product out of Japan, an export license of the Japanese Government is required.

15. USPM Setup Procedure

The method for setting up USPM-RU Ver. 3.21 again will be explained.

[Note 1] USPM-RU Ver. 3.21 is software capable of running on Windows XP. However, notice that Olympus is not in a position to guarantee operation with any other software than the one initially installed.

15.1. Setup of device driver

When a USB type control box is in use:

- With the personal computer started, connect it to the control box through a USB cable, and turn on the power of the control box.
- The Windows XP Hardware Wizard will automatically start up.
- Specify the location of the device driver. Load the Install CD-ROM in the CD-ROM drive, and press the **[Specify Location]** button. Furthermore, specify "D:¥Driver¥CP2101¥Win¥" with the **[View]** button, and close with **[OK]**.
- Close the Hardware Wizard with the **[Complete]** button.

When a GP-IB type control box is in use:

- With the personal computer started, load the GP-IB PC Card in the slot. Then, the Windows XP Hardware Wizard will automatically start up.
- Specify the location of the PC Card driver. Load the Install CD-ROM in the CD-ROM drive, and press the **[Specify Location]** button to display the **[Specify Location]** window. Furthermore, specify "D:¥Driver¥REX5052¥Win¥" with the **[View]** button, and close with **[OK]**.
- Close the Hardware Wizard with the **[Complete]** button.

15.2. Check of PC Card setup

When a USB type control box is in use:

- Start up the system through the control panel. Select Device Manager from Hardware. Click “Port (COM and LPT)”, and ensure that "CP2101 USB to UART Bridge Controller (COM*)" is registered. ("*" denotes the port No. assigned to the control box.)

When a GP-IB type control box is in use:

- Start up the system through the control panel. Select Device Manager from Hardware. Click “Otherdevice”, and ensure that "REX5052 GPIB PC CARD For DOS/V" is registered.

15.3. Setup of USPM-RU Ver. 3.21

- Load the Install CD-ROM in the CD-ROM drive. Click to execute ".\JPN¥install¥setup.exe" on the CD-ROM. Select the program to be installed, according to the table.

Japanese version for 380nm	JPN¥install¥setup.exe
English version for 380nm	ENG¥install_en¥setup.exe
Japanese version for 440nm	JPN¥install440¥setup.exe
English version for 440nm	ENG¥install440_en¥setup.exe

- The **[USPM Setup]** window will open. Press the **[OK]** button to proceed.
- On the screen that opens next, select the directory in which the program is to be installed, and press the button at the upper left. This will initiate the setup. Install the program as instructed by the messages.

Note: If an error is issued during the installation, press the **[Yes]** button and continue with the installation.

- When the installation is finished, **[USPM] (or USPM440)** will be added to the Windows XP **[Start]** menu.
- When the software is launched for the first time after the installation, an error will be displayed, since the uspm.int/uspm.env/uspm.cal files do not exist yet. Clicking **[OK]** will activate the program.

15.4. Modification of uspm.int file

When a USB type control box is in use:

- Open and modify the uspm.int file contained in the installed folder. Enter the number marked in the photometric head section, and save.
- Enter the COM port No. in the (No. of port in use) space of the 3rd line, and save.

When a GP-IB type control box is in use:

- Enter "0" in the (No. of port in use) space of the 3rd line, and save.

<p>1st line: (Data file ID tag)</p> <p>2nd line: (Configuration file name)</p> <p>3rd line: (Port No. in use)</p> <p>4th line: 38 ← Change to the value described at the 1st step.</p> <p>5th line: 77 ← Change to the value described at the 2nd step.</p> <p>6th line: 214 ← Change to the value described at the 3rd step.</p> <p>7th line: 401 ← Change to the value described at the 4th step.</p> <p>8th line: 454 ← Change to the value described at the 5th step.</p> <p>9th line: 485 ← Change to the value described at the 6th step (440 - 840nm excluded).</p> <p>Last line: (Waiting time of shutter) ← In case of 380-780nm, 10th Line is last line. In case of 440-840nm, 9th Line is last line.</p>

16. Contact Address

- This manual has been prepared with utmost care to be perfect. Yet, should you have any questions or comments, or find any error or omission of description in it, please refer to the address of the attached paper.

- The contents of this manual are subject to changes without prior notice for purposes of improvement.

17. SOFTWARE LICENSE AGREEMENT



CAREFULLY READ ALL THE TERMS AND CONDITIONS OF THIS LICENSE AGREEMENT BELOW BEFORE USING THE SOFTWARE.

Product Name : USPM-RUIII

Version : 3.21

THIS IS A VALID AND LEGALLY ENFORCEABLE AGREEMENT BETWEEN YOU (EITHER AN INDIVIDUAL OR A SINGLE ENTITY) AND OLYMPUS CORPORATION ("OLYMPUS"). THE SOFTWARE INCLUDES OLYMPUS' COMPUTER PROGRAM, ASSOCIATED PRINTED MATERIALS, DATA AND INFORMATION, WHICH ARE PROVIDED IN THIS PACKAGE OF SOFTWARE PRODUCT. BY DOWNLOADING, COPYING OR OTHERWISE USING THE SOFTWARE, YOU AGREE TO BE BOUND BY THE TERMS AND CONDITIONS OF THIS AGREEMENT. OLYMPUS GRANTS TO YOU A NON-EXCLUSIVE LICENSE TO USE THE SOFTWARE, PROVIDED THAT YOU AGREE TO THE FOLLOWING TERMS AND CONDITIONS:

Section 1 Intellectual property

All title and copyrights of the Software are owned by Olympus. The Software is also protected by copyright laws and international copyright treaties, as well as other intellectual property laws and treaties. The Software is licensed, not sold.

Section 2 Conditions of use

1. You may copy and use the Software on multiple computers.
2. You may copy the Software for backup purposes.
3. The Software is subject to change without notice.

Section 3 Rental and transfer

You may not rent, lease, sublicense or lend the Software or a copy of the Software. You may, however, transfer all of your rights under this Agreement, provided you retain no copies of the Software, and the recipient agrees to the terms and conditions of this Agreement.

Section 4 Restrictions

1. You may not distribute or reproduce the whole or part of the Software without Olympus' prior approval.
2. You may not create, transfer, sell, distribute, rent or lease any derivative work of the Software.
3. You may not analyze, reverse engineer, decompile or disassemble the Software, DLL or any part of the Software, or print out the Software.
4. You may not combine the Software with or incorporate it into any other application software.
5. You agree that the Software is subject to the export control laws and regulations of Japan, U.S.A. and other competent countries. You shall follow any such applicable export control laws and regulations of Japan, U.S.A. and other countries.
6. You may not alter, erase or deface any trademark, warning, copyright and other notice on the Software.

Section 5 Limited warranty

Olympus warrants that any original disk on which the Software is recorded is free from substantial physical errors or defects that will materially interfere with the operation or functions of the Software within ninety (90) days after you purchase the Software or a product containing the Software. OLYMPUS DOES NOT WARRANT THAT ALL ERRORS OR DEFECTS WILL BE CORRECTED. OLYMPUS' EXCLUSIVE REMEDY SHALL BE REPLACEMENT OF SUCH A DISK WHICH DOES NOT MEET THE SAID LIMITED WARRANTY AND WHICH IS RETURNED TO OLYMPUS WITH A COPY OF YOUR RECEIPT.

Section 6 Disclaimer

1. EXCEPT FOR THE LIMITED WARRANTIES PROVIDED HEREIN, THE SOFTWARE IS PROVIDED TO YOU "AS IS" WITHOUT WARRANTY OF ANY KIND, EITHER EXPRESSED OR IMPLIED, INCLUDING, BUT NOT LIMITED TO, WARRANTIES OF NON-INFRINGEMENT, MERCHANTABILITY, AND/OR FITNESS FOR A PARTICULAR PURPOSE.
2. OLYMPUS SHALL NOT BE HELD LIABLE FOR ANY DAMAGES SUFFERED OR INCURRED BY YOU OR ANY OTHER THIRD PARTY (INCLUDING, BUT NOT LIMITED TO, GENERAL, SPECIAL, DIRECT, INDIRECT, CONSEQUENTIAL OR INCIDENTAL DAMAGES INCLUDING DAMAGES FOR LOSS OF BUSINESS PROFITS, BUSINESS INTERRUPTION, LOSS OF BUSINESS INFORMATION AND THE LIKE), ARISING OUT OF OR IN CONNECTION WITH THE DELIVERY, USE OR PERFORMANCE OF THE SOFTWARE.

Section 7 Third party software

IN CASE OLYMPUS PROVIDES ANY THIRD PARTY SOFTWARE PRODUCT ("THIRD PARTY SOFTWARE") WITH THE SOFTWARE, SUCH THIRD PARTY SOFTWARE IS PROVIDED TO YOU "AS IS" WITHOUT WARRANTY OF ANY KIND, EITHER EXPRESSED OR IMPLIED, INCLUDING, BUT NOT LIMITED TO, WARRANTIES OF NON-INFRINGEMENT, MERCHANTABILITY, AND/OR FITNESS FOR A PARTICULAR PURPOSE. OLYMPUS SHALL NOT BE HELD LIABLE FOR ANY DAMAGES SUFFERED OR INCURRED BY YOU OR ANY OTHER THIRD PARTY (INCLUDING, BUT NOT LIMITED TO, GENERAL, SPECIAL, DIRECT, INDIRECT, CONSEQUENTIAL OR INCIDENTAL DAMAGES INCLUDING DAMAGES FOR LOSS OF BUSINESS PROFITS, BUSINESS INTERRUPTION, LOSS OF BUSINESS INFORMATION AND THE LIKE), ARISING OUT OF OR IN CONNECTION WITH THE DELIVERY, USE OR PERFORMANCE OF SUCH THIRD PARTY SOFTWARE. FURTHERMORE, FOR USING ANY THIRD PARTY SOFTWARE, YOU ARE SUBJECT TO THE TERMS AND CONDITIONS OF THE LICENSE AGREEMENT OF SUCH THIRD PARTY SOFTWARE.

Section 8 Effective period

1. This Agreement shall become effective as of the date when you receive the Software or a product containing the Software.
2. Without prejudice to any other rights, Olympus may terminate this Agreement if you fail to comply with the terms and conditions of this Agreement. In such event, you must destroy all copies of the Software and all of its component parts.

Section 9 Governing law and jurisdiction

1. This Agreement shall be governed by, performed under and construed in accordance with the laws of Japan.
2. With regard to any related legal action, you agree to exclusive jurisdiction and venue in Tokyo, Japan.

USPM-RU/RUIII Installation Instructions

(Ver 3.21)

OLYMPUS®



Before use

We thank you for purchasing the USPM-RU/RUIII. To derive the best performance from this product, and to use this product safely, be sure to read this instruction manual when you reinstall USPM-RU/RUIII. After reading this manual, keep it in a safe and convenient place for future use.

In particular, when you perform a version upgrade or reinstallation on a PC where the program is already installed, you should perform the following procedures first: "7. Backing Up the Settings Files", "8. Uninstalling the Communications Driver", "9. Uninstalling the GPIB USB Connecting Driver", and "10. Uninstalling the USPM-RU/RUIII Program".

If a necessary file is deleted by mistake during these uninstallation operations, the PC may not operate properly.

Installation-related operations must be performed by personnel who have adequate knowledge and experience in the operation of a personal computer and an interferometer, and have carefully read this manual.

TABLE OF CONTENTS

1. INTRODUCTION	4
2. INSTALLATION PROCEDURES	7
3. INSTALLING THE USPM-RU/RUIII PROGRAM	8
4. INSTALLING THE COMMUNICATIONS DRIVER	10
5. INSTALLING THE GPIB USB CONNECTING DRIVER	13
6. SETTING THE WAVELENGTH CALIBRATION DATA	15
7. BACKING UP THE SETTINGS FILES	16
8. UNINSTALLING THE COMMUNICATIONS DRIVER	17
9. UNINSTALLING THE GPIB USB CONNECTING DRIVER	19
10. UNINSTALLING THE USPM-RU/RUIII PROGRAM.....	21

1. Introduction

(1) Preparation

Prepare the following before installing the program.

[For the USB-cable version(for USPM- RUIII)]

- 1) The computer into which the program is to be installed
- 2) The program installation CD-ROM
- 3) The control box (UCB-01) and USB cable.

[For the GPIB-USB connect version(for USPM-RU)]

- 1) The computer into which the program is to be installed
- 2) The program installation CD-ROM
- 3) The GPIB USB Cable.

(2) Computer (PC) specifications

The following system configuration is required to operate the program.

[Windows10]

- 1) CPU: made by Intel Corporation
- 2) Chipset: made by Intel Corporation (*1)
- 3) Memory: 4GB or greater required
- 4) OS: Windows 10 Professional 64bit
- 5) CD-ROM drive (external drive can also be used)
- 6) USB 2.0 x 1 port (2 ports or greater is recommended)
- 7) Screen resolution: 1024 x 768 or greater
- 8) Set the power management settings so as not to turn off the hard disk power.

[Windows7]

- 1) CPU: made by Intel Corporation
- 2) Chipset: made by Intel Corporation (*1)
- 3) Memory: 1 GB or greater required (2 GB or greater is recommended)
- 4) OS: Windows 7 Professional or Windows 7 Business 32bit
- 5) CD-ROM drive (external drive can also be used)
- 6) USB 2.0 x 1 port (2 ports or greater is recommended)
- 7) Screen resolution: 1024 x 768 or greater
- 8) Set the power management settings so as not to turn off the hard disk power.

*1 Proper operation may not be guaranteed if a different chipset is used.

(3) Note on the OS login ID

When installing the program or the device driver, be sure to first log in to the OS with administrator user rights (as Administrator, etc.).

(4) Installation into a PC

It is necessary to disable the user account control setting before installation. The user account control setting can be disabled using the following procedure.

1) Select "Control Panel" from "Start Menu".

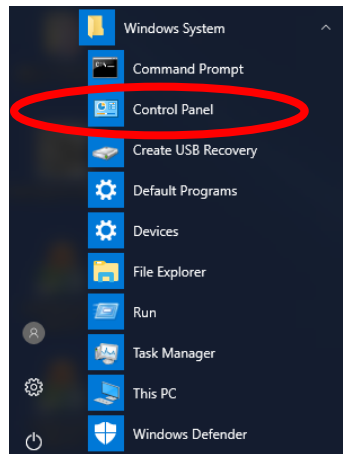

2) On the first screen, click "User Accounts".

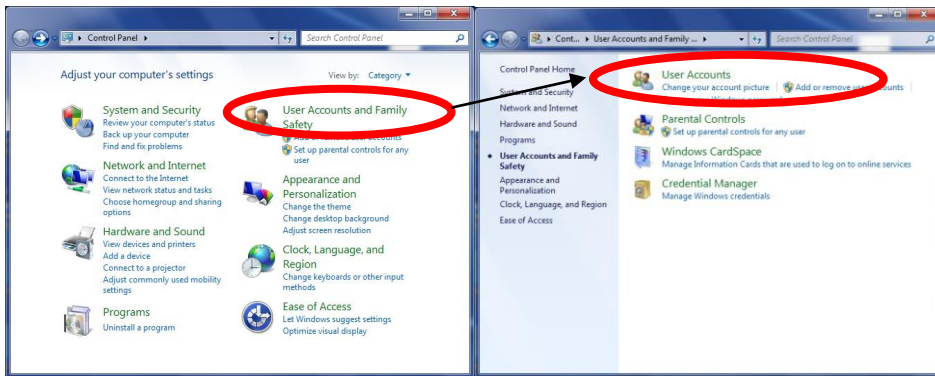

3) On the next screen, click "Turn User Account Control on or off".

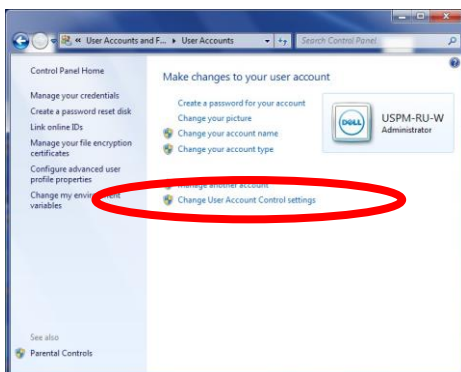

- 4) On the next screen, set “Choose when to be notified about changes to your computer” to “Never notify”.

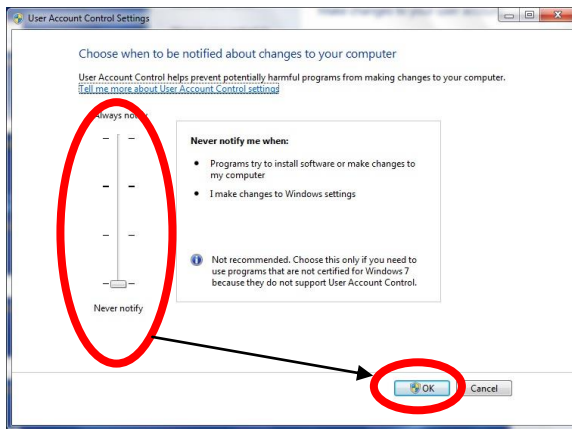

- 5) A dialog box asking you to restart the computer is displayed. Restart the computer. In case a dialog box asking you to restart the computer is not displayed, restart the computer.
- 6) Here is Power Supply Setting. Select “Power Options”, and display Power Supply Setting Window by clicking items that indicated by arrows shown in a below chart. Then select “No” or “Never” for all of items.

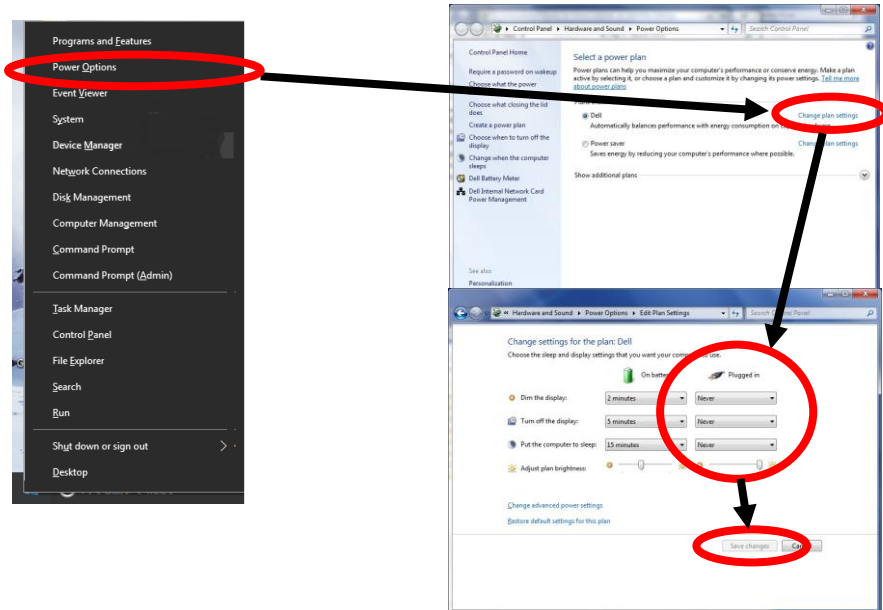

2. Installation Procedures

For installation or uninstallation, follow the procedures below.

- * For reinstallation into a personal computer where the program is already installed, first uninstall the existing version, and then install the new version.
- * When a new installation is performed or if you do not need to restore existing settings, item “3(5). Restoring the Backed-up Settings Files” is not necessary.

(1) Installation

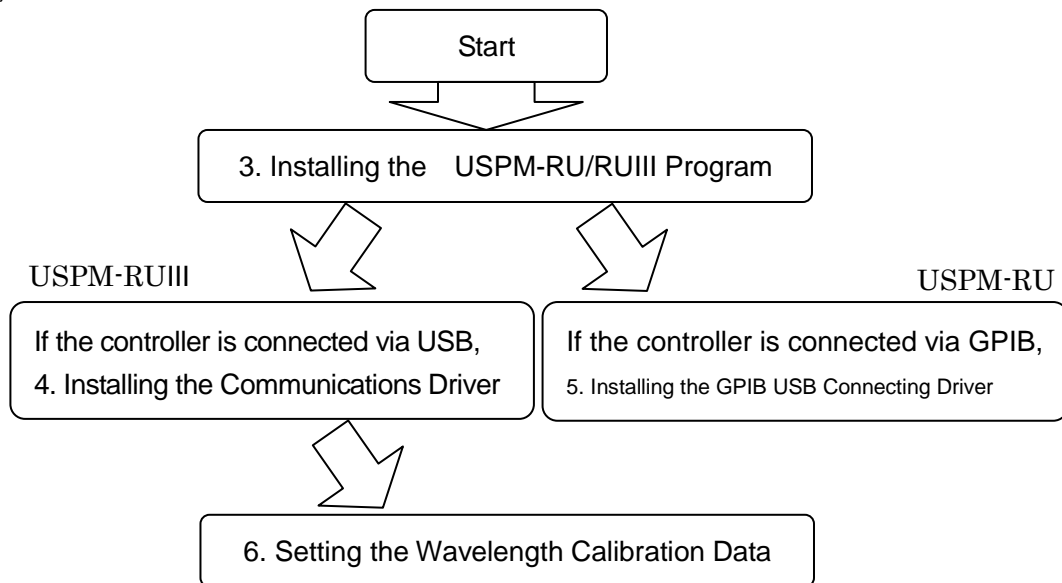

(2) Uninstallation

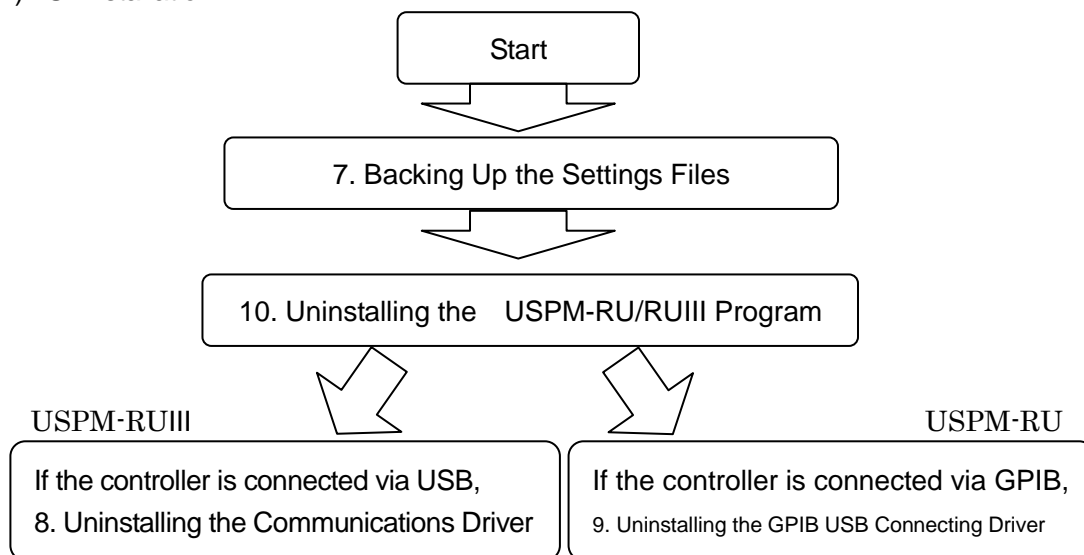

3. Installing the USPM-RU/RUIII Program

- (1) Open Explorer, and open the “JPN” folder on the CD-ROM. Open the “install” (for 380 nm) folder or the “install440” (for 440 nm) folder at the lower level, and double-click “Setup.exe” to execute it.

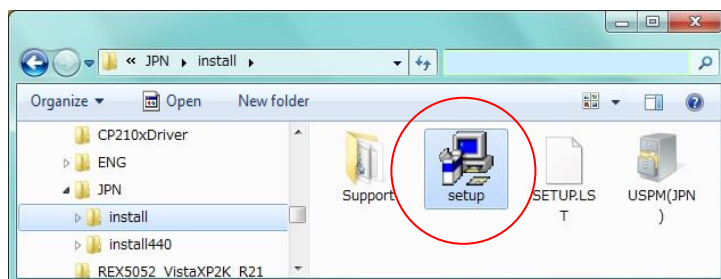

- * The Japanese version of the program is stored in the “JPN” folder, and the English version of the program is stored in the “ENG” folder. The program supporting the 380 nm measuring head is stored in the “install” folder, and the program supporting the 440 nm measuring head is stored in the “install440” folder.

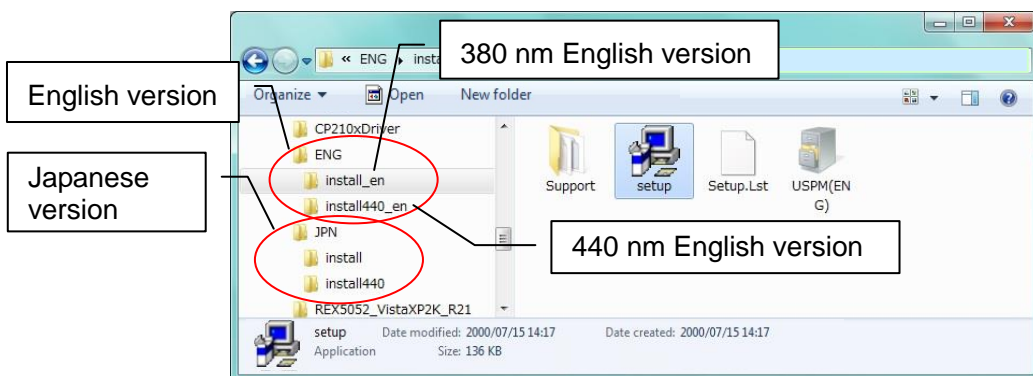

- (2) When a message of Setup start is displayed, click OK button. The setup dialog box will be displayed. Click on the icon.

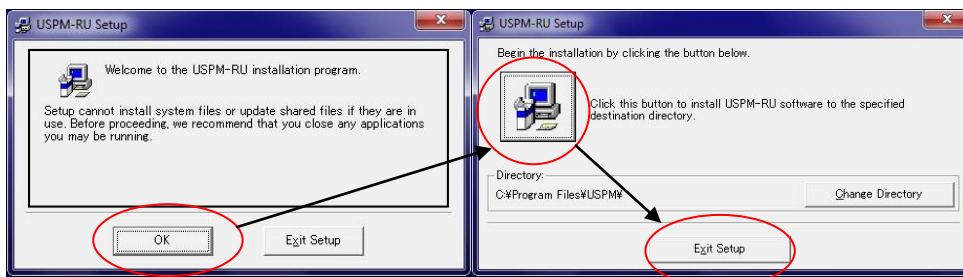

- (3) The following dialog box will be displayed. Click “Continue”. When a version up message is displayed during installation, click “No” button.

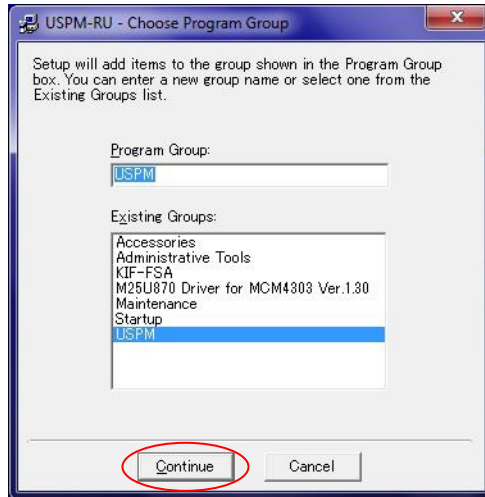

- (4) A dialog box indicating completion of the setup will be displayed. Click “OK”.

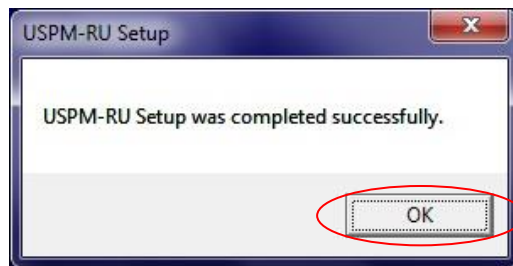

- (5) The procedures are complete for a first installation. If this is a reinstallation and you would like to restore the previous settings, overwrite (replace) the files in the original location (installation destination) with the saved files in “7. Backing Up the Settings Files”.
- (6) Create a shortcut on the desktop. Select and right-click on the “USPM.exe” file located in the folder into which the USPM-RU/RUIII program has been installed (C:¥USPM or ¥USPM440 by default). Click “Send to” – “Desktop (create shortcut)”. A shortcut will be created on the desktop.

4. Installing the Communications Driver

* The installation in this chapter is to be performed when the controller of the main unit is connected via USB. The installation procedures may differ depending on the settings of the personal computer on which the installation is performed, or may differ if it is a reinstallation.

- (1) Double-click to run “CP210xVCPInstaller_x64 (.exe)” in the “CP201xDriver”
([Windows7] “_WIN7\CP210xVCPInstaller_x86 (.exe)” in the “CP201xDriver”) folder of the CD-ROM.
- (2) In the following screen, click the “Next” button to proceed.

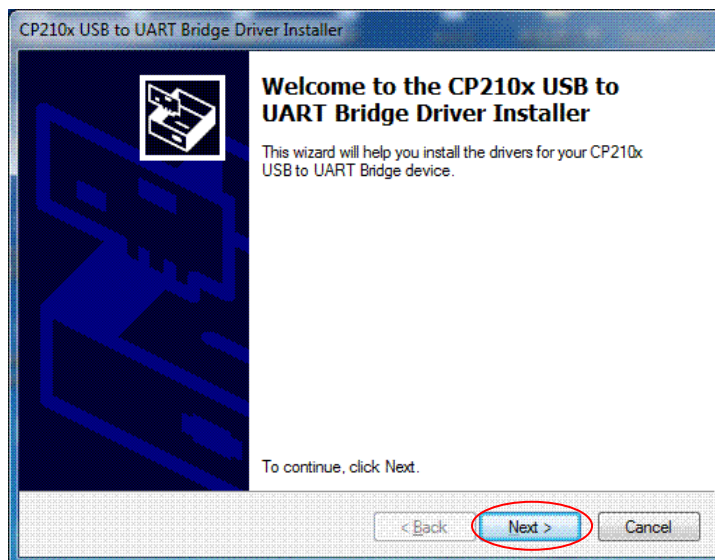

- (3) In the following screen, select the “I accept this agreement” check box and click the “Next” button to proceed.

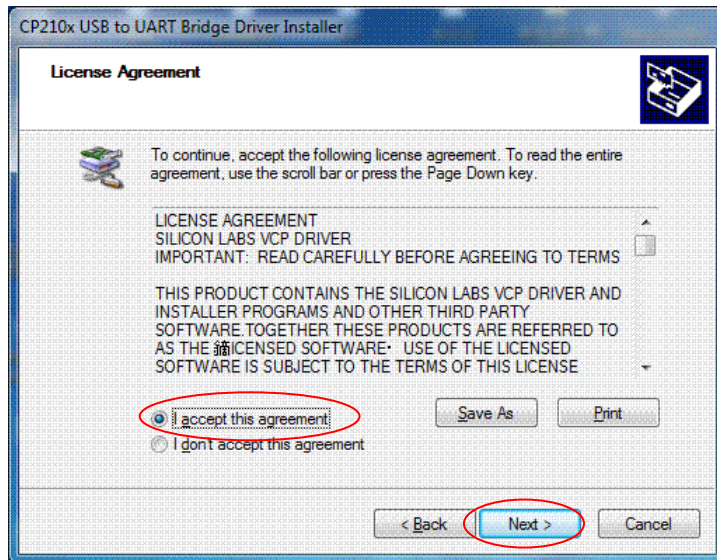

- (4) Finally press the Finish button to complete the operation.

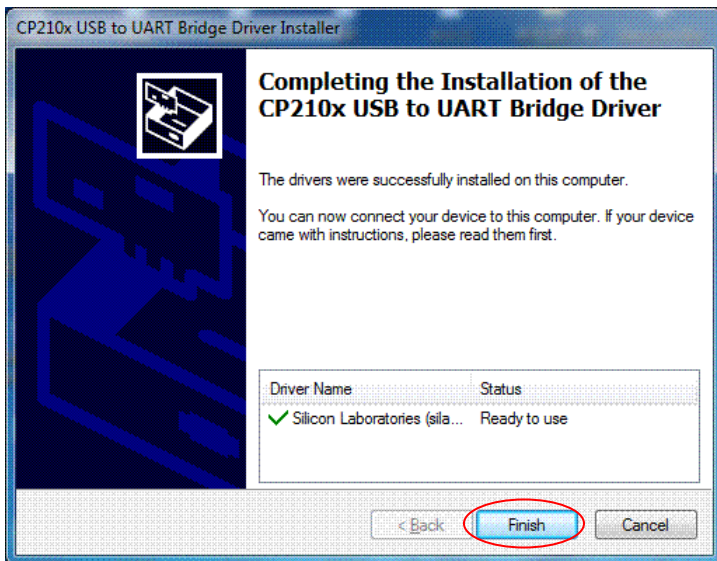

- (5) Next, set the port number. Select “Start Menu” -> “Control Panel” -> “Hardware and Sound”, and select “Device Manager”.
- (6) Click the + mark next to “Ports (COM & LPT)” to display the connected serial ports. If “Silicon Labs CP210x USB to UART Bridge (COM3)” is displayed, COM3 represents the port number.

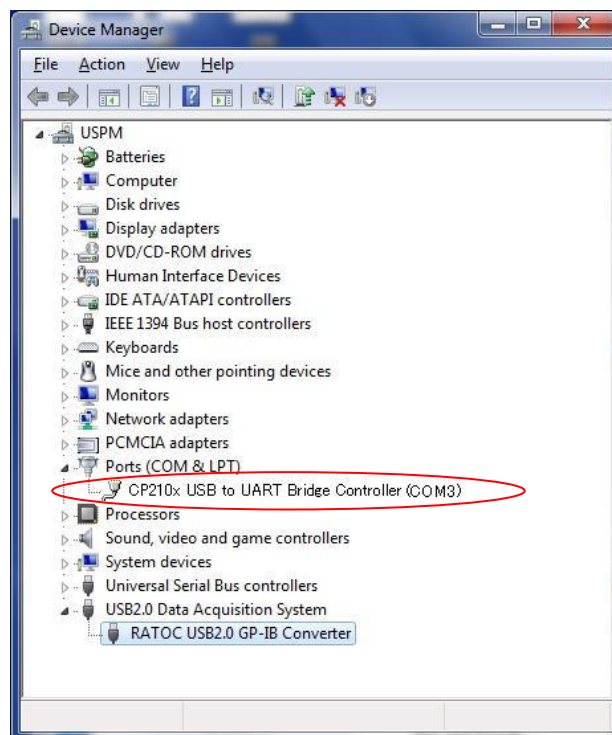

- (7) Double-click to open the “USPM.int” file located in the folder into which the USPM-RU/RUIII program has been installed (C:¥USPM or ¥USPM440 by default). If it cannot be opened, right-click on the “USPM.int” file, select “Open with”, and select Notepad to open it.

* “.int” will not appear if the “Hide extensions for known file types” setting is applied.

- (8) Check the numerical value that appears on the third line of the “USPM.int” file. This number represents the serial port number, for which the default value is 5. Specify the serial port number that you confirmed in “Device Manager”. In the example above, “COM3” was displayed, so you would type 3. After the setting is complete, save and close the file. If the file is read-only and cannot be overwritten, clear the “Read-only” check box in the file properties and save the file again.

5. Installing the GPIB USB Connecting Driver

If you are using the USB-cable version, perform the following settings. Installment is started without connecting GRIP USB connecting cable to the Computer.

- (1) Double-click to run “USB220_Setup_for_Win10(.exe)” in the “REXUSB220” ([Windows7] “USB220_Setup(.exe)” in the “_WIN7¥REXUSB220”) folder of the CD-ROM.

* The extension (.EXE) might not appear, depending on the OS settings.

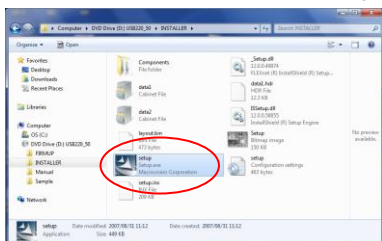

- (2) Click the “Next” button to proceed.



- (3) Click the “Install” button to start the installation.

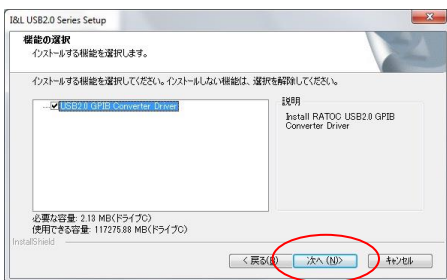

- (4) Click the “Finish” button. The installation is complete.

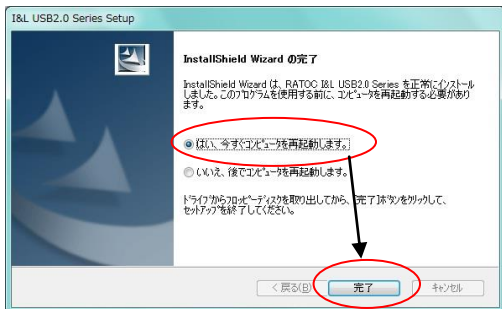

- (5) Confirm restarting the computer is completed, then connect GRIP USB Connecting Cable into USB Connector.
- (6) Next, perform the initial settings by editing the settings file contents. Double-click to open the "USPM.int" file located in the folder into which the USPM-RU/RUIII software has been installed (C:\USPM or \USPM440 by default). If it cannot be opened, right-click on the "USPM.int" file, select "Open with", and select Notepad to open it.
- (7) Check the numerical value that appears on the third line of the "USPM.int" file. This number represents the serial port number, for which the default value is 5. Type 0 for the setting. After the setting is complete, save and close the file.

6. Setting the Wavelength Calibration Data

If you are using the USB-cable version, perform the following settings.

- (1) Double-click to open the “USPM.int” file located in the folder into which the USPM-RU/RUIII program has been installed (C:¥USPM¥ or ¥USPM440 by default). If it cannot be opened, right-click on the “USPM.int” file, select “Open with”, and select Notepad to open it.
- (2) Enter the numerical values found on the measuring head, as shown below, and save the file.

Example of the numerical values on the measuring head

1: <u>38</u>	2: <u>77</u>
3: <u>214</u>	4: <u>401</u>
5: <u>454</u>	6: <u>485</u>

Example of the description in the USPM.int file

1st line	:	(Data file identification tag)
2nd line	:	(Configuration file name)
3rd line	:	(Used port number)
4th line	:	38 ← Set the numerical value for item 1 in the box on the left.
5th line	:	77 ← Set the numerical value for item 2 in the box on the left.
6th line	:	214 ← Set the numerical value for item 3 in the box on the left.
7th line	:	401 ← Set the numerical value for item 4 in the box on the left.
8th line	:	454 ← Set the numerical value for item 5 in the box on the left.
9th line	:	485 ← Set the numerical value for item 6 in the box on the left. (*1)
Last line	:	(Shutter waiting time)

*1: There is no 9th line in the 440-840 nm specification.

7. Backing Up the Settings Files

The setting files listed below will be deleted when an uninstallation is performed. If you want to continue to use the current settings after an uninstallation is performed, copy the files below to another location, and return them to the original location after a new installation is performed.

File name	Remarks
C:\%USPM%\uspm.cal	or ¥USPM440
C:\%USPM%\uspm.env	or ¥USPM440
C:\%USPM%\uspm.int	or ¥USPM440 The extension (.int) is not displayed.

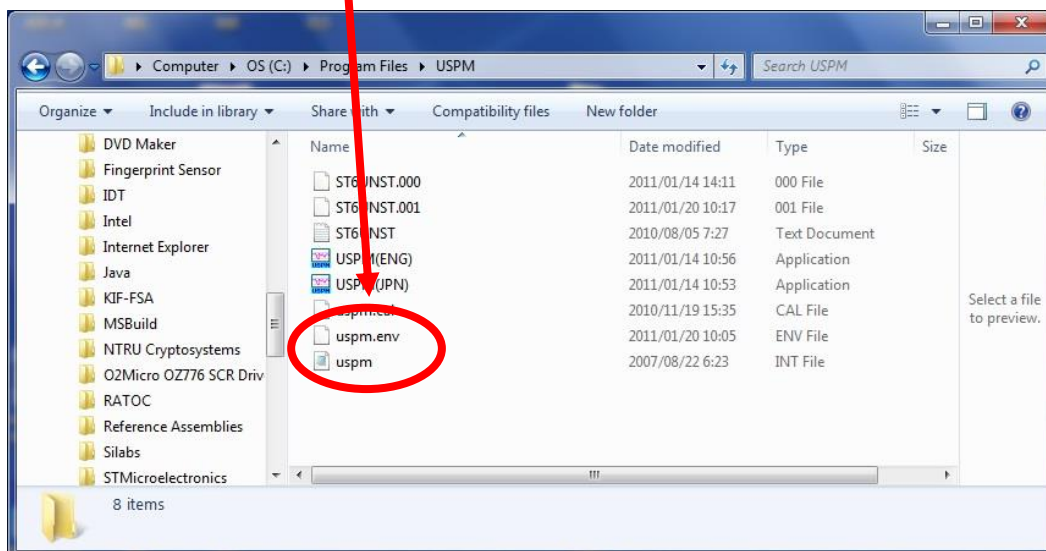

8. Uninstalling the Communications Driver

- (1) Select “Control Panel” from “Start Menu”.

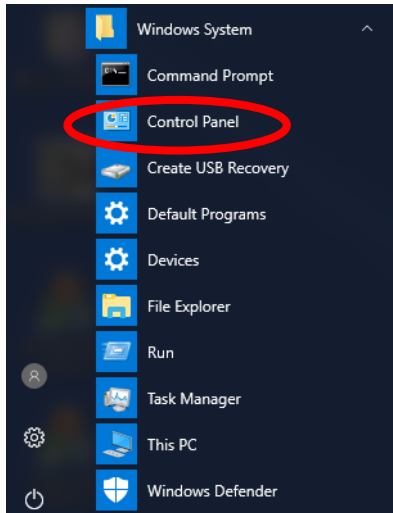

- (2) Click “Add or Remove Programs” or “Programs and Features”.

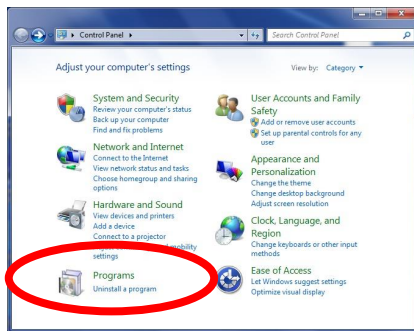

- (3) First select “Windows Driver Package – Silicon Laboratories (silaberm) Ports” and then start the uninstallation using the “Uninstall/Change” button.

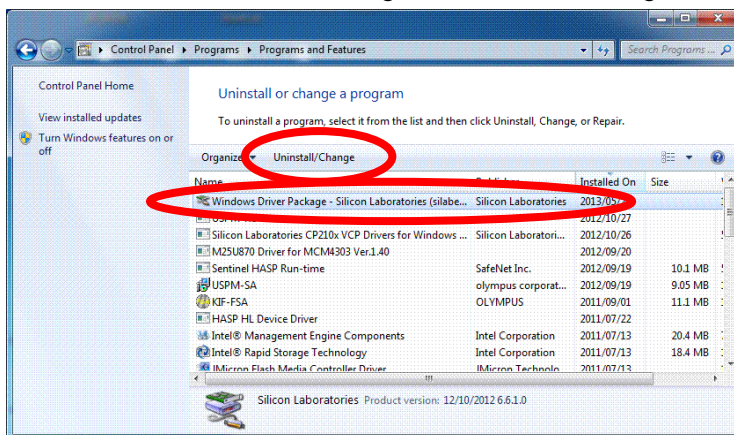

(4) In the following screen, click the Yes button to complete the uninstallation.

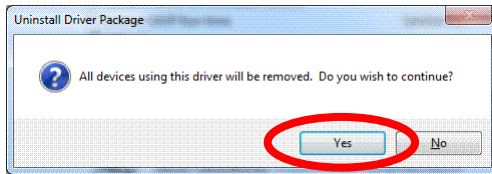

9. Uninstalling the GPIB USB Connecting Driver

(1) Open "Control Panel" from "Start Menu".

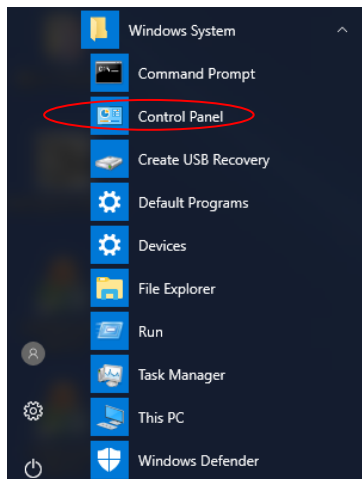

(2) Click "Programs". (If you are using the classic view, proceed to Step (3).)

(3) Click "Programs and Features". (If you are using the classic view, proceed to Step (4).)

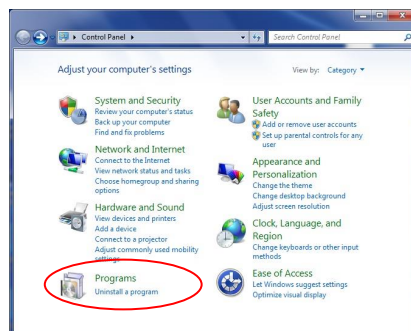

(4) Select "RATOC I&L USB2.0 Series", and click "Remove" or "Uninstall".

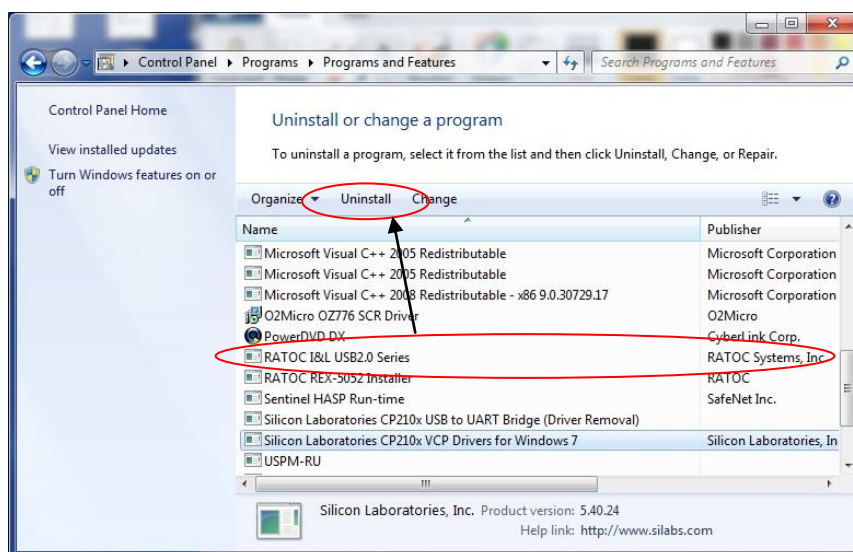

- (5) If the dialog box indicating that the uninstallation is complete is displayed, click “Finish” or “OK”.

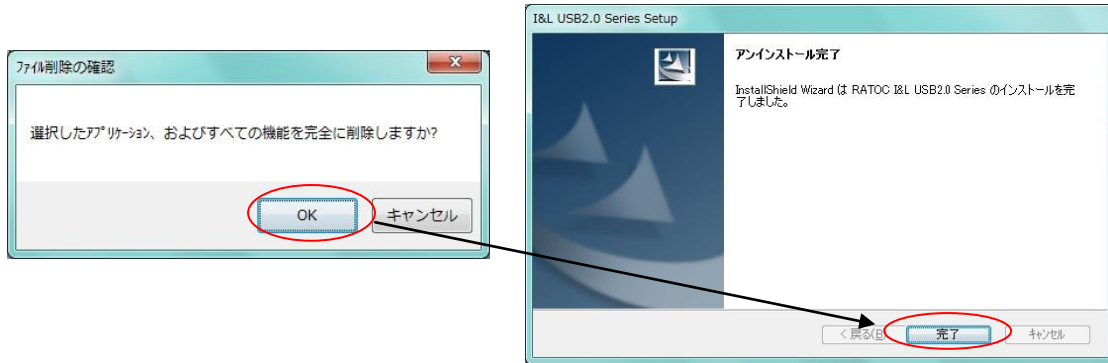

- (6) Wait until the uninstallation is complete.
- (7) When the dialog box disappears, the uninstallation process is complete.

10. Uninstalling the USPM-RU/RUIII Program

When you perform a reinstallation on a PC where the USPM-RU/RUIII program is already installed, uninstall the program by following the procedures below.

(1) Open "Control Panel" from "Start Menu".

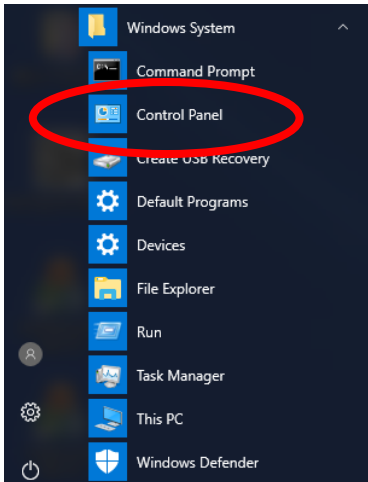

(2) Click "Add or Remove Programs" or "Programs and Features".

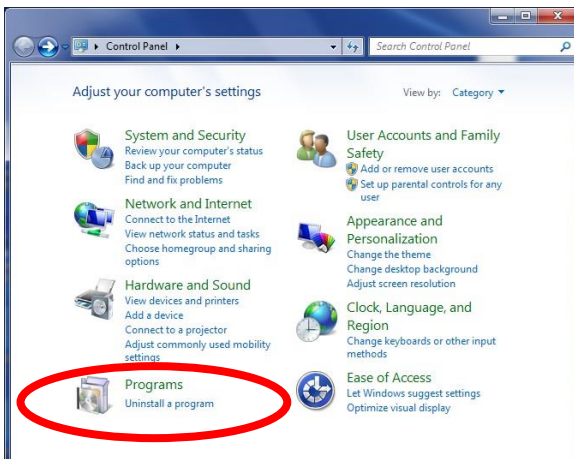

(3) Select “USPM-RU”, and click “Remove” or “Uninstall”.

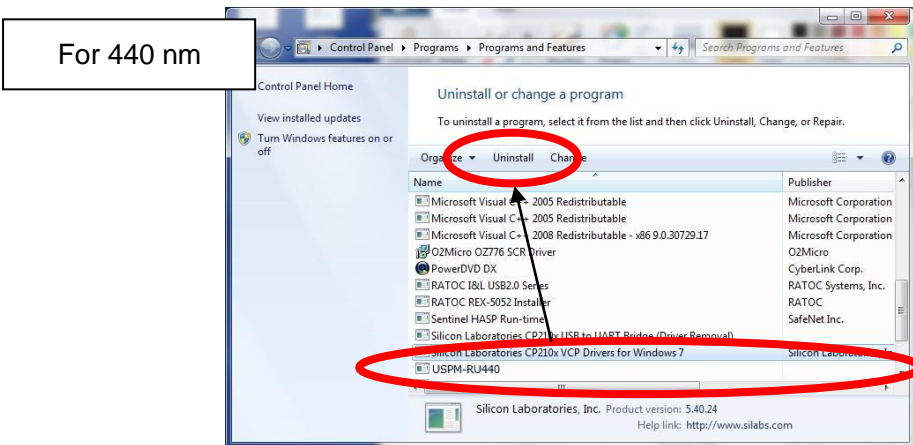
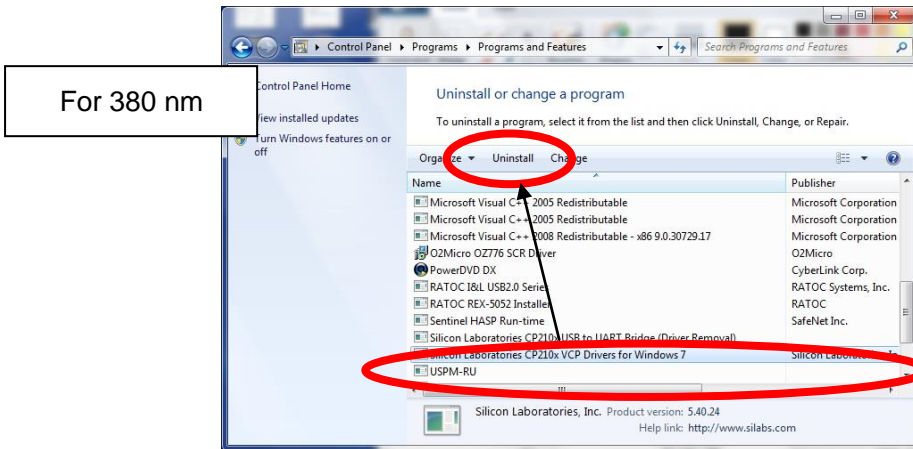

- (4) If the "Add or Remove Programs" confirmation dialog box is displayed, click “Yes”.
- (5) If the “Delete shared file” confirmation dialog box is display, click “Delete All”.
- (6) If files have been moved in “7. Backing Up the Settings Files”, a message indicating that a file does not exist is displayed. Confirm the message contents and close the message dialog box. The uninstallation will continue.
- (7) Wait until the uninstallation is complete. When the message(U2GPLIB.DLL is not found.) is displayed during uninstallation, "OK" is pushed.
- (8) When the message indicating that the uninstallation is in process disappears, the uninstallation process is complete. If a dialog box confirming the completion is displayed, close the dialog box. Close “Programs and Features” and “Control Panel”.

Optical Measuring Instrument
Accessory

Operation Manual
for the U-CT30-2 for the USPM-RUIII
(Optional)

OLYMPUS®

Introduction



Before using the device

Thank you for purchasing the OLYMPUS Centering Telescope U-CT30-2, designed for the USPM-RUIII Lens Reflect meter (optional). To maximize the performance of this optional device and ensure its safe use, be sure to read this manual and the Hardware and Software Operation Manuals for the USPM-RUIII Lens Reflect meter before using it. After reading the manual, keep it in a safe place where you can refer to it easily when needed.

Safety precautions

Symbol marks and terms used in this manual

In this manual, the symbol marks and terms below are used in accordance with the description contents. The symbol marks and terms are described for each safety level. To use the unit safely and properly, thoroughly understand the contents of symbol marks and terms.

 WARNING	Indicates that serious personal injury or death may result due to fire or electrical shock if not followed.
 CAUTION	Indicates that injury or material damage may result due to an electrical shock or other accidents if not followed.

■ Symbols denoting prohibition (prohibited actions)



Prohibited



Disassembly
prohibited

■ Symbols denoting obligation (mandatory actions)



Mandatory



Unplugged



Grounded

■ Symbols denoting caution



Caution



Caution against
ignition



Caution against
electric shock



Failure to follow these precautions may result in serious personal injury or death due to fire or electrical shock.



Prohibited

- Do not place the unit in a location subject to lamp smoke, vapor, moisture, or excessive dust.

Doing so may cause fire or electrical shock. Do not place the unit in a location subject to direct sunlight or near heating equipment or thermal equipment, where the temperature becomes abnormally high or low; or subject to moisture or excessive dust.



Prohibited

- Do not put water or foreign objects in the unit.

Doing so may cause a fire or electrical shock. If water or foreign objects should be put in the unit, immediately turn off the power, remove the power plug from the wall outlet, and contact the sales office.



Disassembly prohibited

- Do not disassemble or remodel the unit.

Doing so may lead to fire, electrical shock, or injury. If you notice an unusual smell, noise or any other abnormal condition, switch off the device immediately and remove the power plug from the wall outlet. Contact your OLYMPUS sales representative to have it repaired. Never make repairs by yourself because doing so is dangerous.



Failure to follow these precautions may result in injury or material damage to peripheral products.



Prohibited

- Do not operate the unit with wet hands.
Operating the unit or removing and inserting a power plug with wet hands may cause electrical shock.



Prohibited

- Do not place the unit anywhere unstable.
When the unit is put on an unstable stand, inclined place, or rigid floor, it may tip over or fall, resulting in injury. This may also damage the floor. Check the installation place fully for strength and inclination.



Caution

- Be careful when focusing the device.
Be very careful to avoid bumping the objective lens against the sample when you are focusing.

1. Features

The Centering Telescope U-CT30-2 is an optional item that is designed to be mounted on the USPM-RUIII Lens Reflect meter. It enables the measurement point to be brought easily to the apex of the lens under inspection.

2. Installing the centering telescope

- (1) Remove the U-CT30-2 Centering Telescope from the packaging.

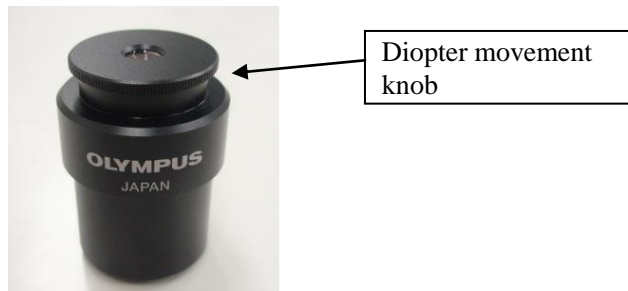

Figure 1. U-CT30-2 Centering Telescope

- (2) Insert the U-CT30-2 Centering Telescope into the left side of the photometric body tube, as shown in Figure 2.

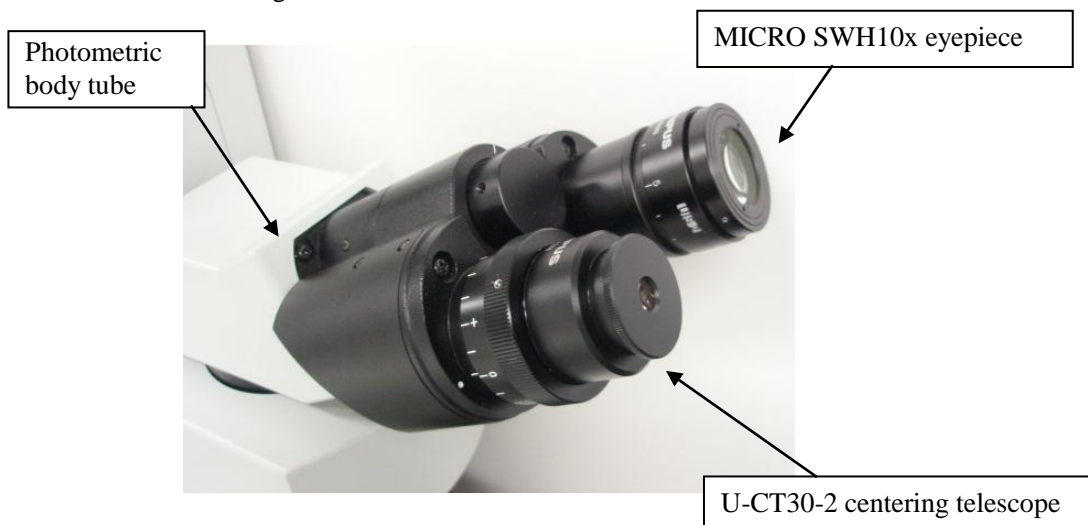

Figure 2. Installation diagram

3. Operating the centering telescope

For details on how to take measurements, see the Hardware and Software Operation Manuals for the USPM-RUIII Lens Reflect meter.

- (1) First, start the system, conduct background and reference measurements, and then place the lens to be inspected on the stage.
- (2) Bringing the measurement point to the surface of the lens under inspection
Look into the eyepiece (MICRO SWH10x) on the right side of the main unit and focus on the surface of the lens being inspected, as shown in Figure 3.

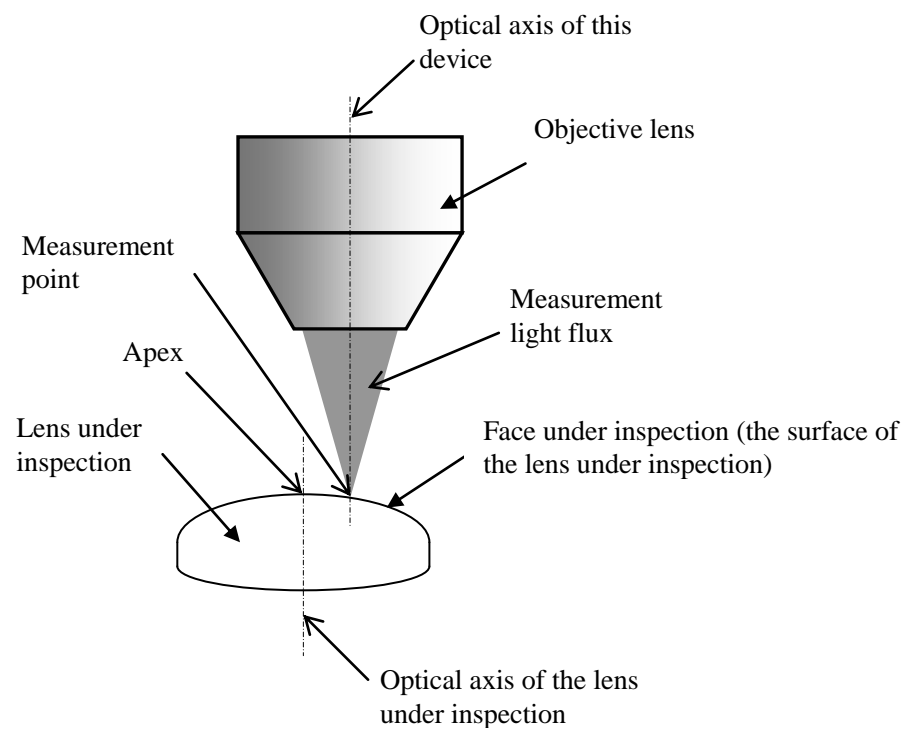

Figure 3. Measurement layout

(3) Bringing the measurement point to the apex

If you look into the centering telescope on the left side of the main unit, you will see in the field of view an image like the one shown in Figure 4. To get a better view of the image, adjust its size by turning the diaper movement knob. Use the stage movement mechanism to bring the image into the center of the field of view.

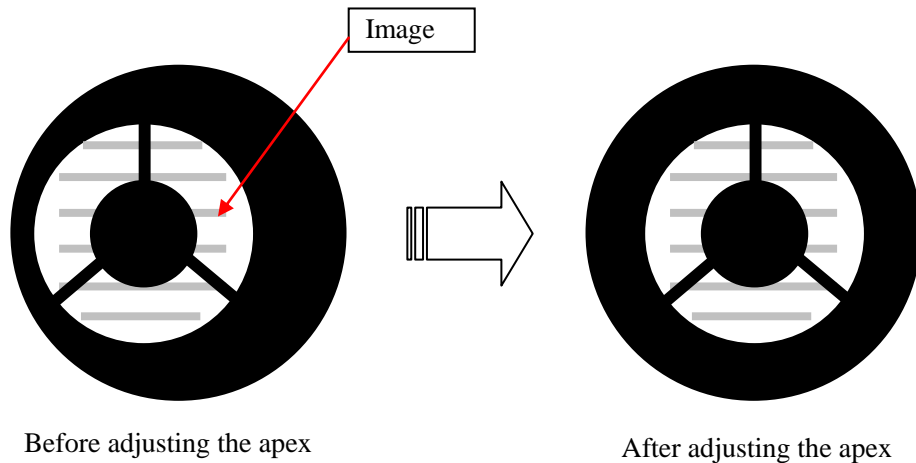

Figure 4. Image observed in the centering telescope

Note: If you do not see any image, it is likely that the lens under inspection is far from the optical axis of the main unit. In this case, directly observe the lens under inspection and move it so that its apex comes onto the optical axis of this device.

- (4) Once again, look into the eyepiece on the right side of the main unit and focus on the surface of the objective lens. (For more information, see the Software Operation Manual.)
- (5) Follow the instructions in the Software Operation Manual to carry out measurements.

連絡先 Contact information

オリンパス株式会社

OLYMPUS CORPORATION

〒163-0914 東京都新宿区西新宿2-3-1新宿モノリス

Shinjuku Monolith , 3-1,Nishi Shinjuku 2-chome ,Shinjuku-ku ,Tokyo ,163-0914, Japan

TEL.0120-58-0414

FAX.03-6901-4251 (+81-3-6901-4251)

OLYMPUS KOREA CO., LTD.

8F Olympus Tower , 446 Bongeunsa-ro , Gangnam-gu, Seoul , Korea , 135-509

Tel: +82-2-6255-3458

OLYMPUS (THAILAND) CO., LTD.

159 Serm-mit Tower, 9th floor, unit# 906-910, Sukhumvit21 road, North Klongtoey, Wattana, Bangkok 10110, Thailand

Tel: +662-260-2730

Fax: +662-260-6600

OLYMPUS AMERICA INC. (USPM-RUIII only)

3500 Corporate Parkway, Center Valley, Pennsylvania 18034-0610, U.S.A

Tel: +1(800)446-5967

Fax:+1(484)896-7131

销售商名称-地址

奥林巴斯（中国）有限公司

上海分公司：

上海市徐汇区淮海中路1010号嘉华中心10楼

电话：021-5158-2084

广州分公司：

广州市环市东路403号广州国际电子大厦1601室

电话：020-61227171