

# IPLEX GAir Operation Manual

**Before handling this product, please read through and follow the instructions and precautions in the instruction manual of the IPLEX GAir.**

**This operation manual is an excerpt from the descriptions and instructions in the instruction manual of the IPLEX GAir, which includes the setup procedures, the functions of basic operating components, descriptions on the indicator and menu displays, and safety precautions during the use of this product.**

## Intended use

This instrument is intended for inspecting and observing the interior of machinery, equipment, materials, and other objects, without damaging the object being inspected.

## Setting up IPLEX GAir

This product can be set up easily for any user to start inspection immediately.

Simply follow the four steps below to complete the setup.

### 1 Removing the units from the carrying case

Remove accessories from the carrying case first, and then remove in the order of units and the main unit from the top cover.

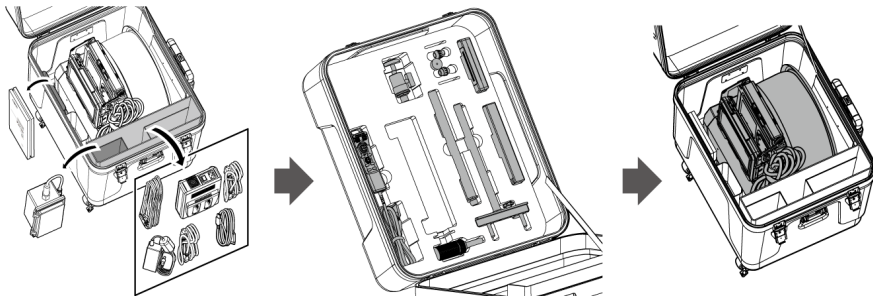

### 2 Preparing the power supply

#### When using the battery

Follow the steps below to load the battery.

1. Slide the release knob of the battery door to open the door.

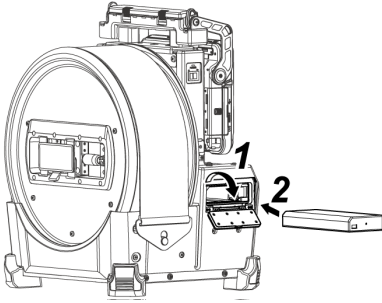

2. Insert the battery while paying attention to the orientation of the battery. Make sure that the battery is locked in place, and close the door.

When using the external battery

Follow the procedures below to connect the external battery

1. Insert the eight external batteries straight in the external battery case paying attention to the orientation of the external batteries, and close the latch (A) of the case.

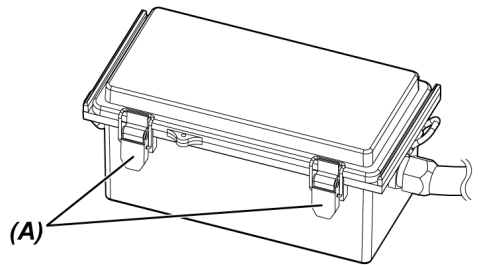
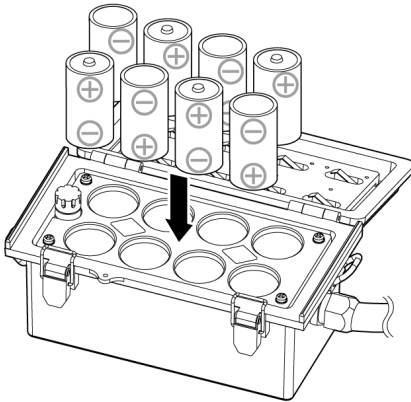

2. Hang the strap of the case over the handle of the drum unit.

3. Attach the case connector to the Ext-Batt.-IN terminal on the drum unit.

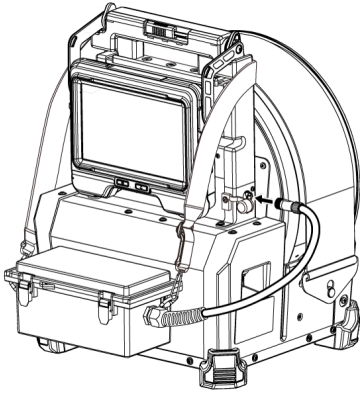

When using the AC adapter

Follow the procedures below to connect the AC adapter.

1. Open the DC-IN terminal cap (A) on the drum unit.

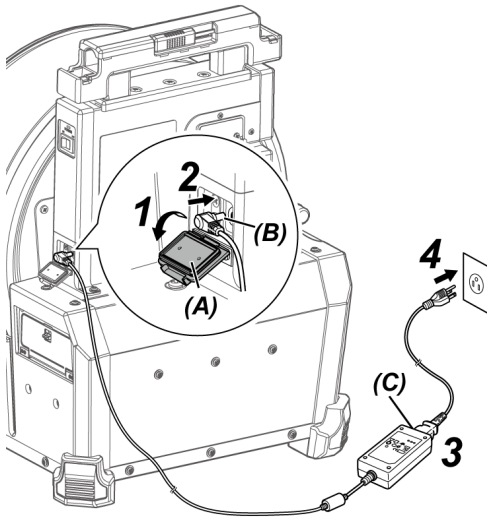

2. Connect the connector (B) for power supply of the AC adapter to the DC-IN terminal of the drum unit.
3. Connect the AC power cord to the AC inlet (C) of the AC adapter.
4. Connect the plug of the AC power cord securely to a power outlet.

### 3 Attaching the optical adapter

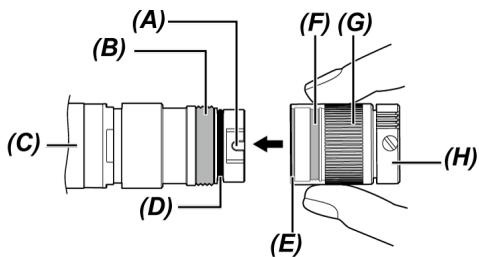

	Name
(A)	Optical adapter positioning groove
(B)	Connecting screw thread
(C)	Distal end
(D)	O-ring
(E)	First screw thread
(F)	Second screw thread
(G)	Nut
(H)	Optical adapter

- 1. Holding the optical adapter and the distal end so that they make one straight line each other, carefully insert the optical adapter into the distal end.**
- 2. Rotate the nut of the optical adapter clockwise until the connecting screw thread passes over the first screw thread.**
- 3. After passing the first screw thread, rotate the optical adapter main body clockwise while pushing it gently until the optical adapter main body is engaged with the positioning pin of the insertion tube and stops rotating anymore.**
- 4. Rotate the nut of the optical adapter clockwise to attach the connecting screw thread to the second screw thread. Tighten the nut until it stops completely.**

### 1. Turn ON the main switch of the drum unit.

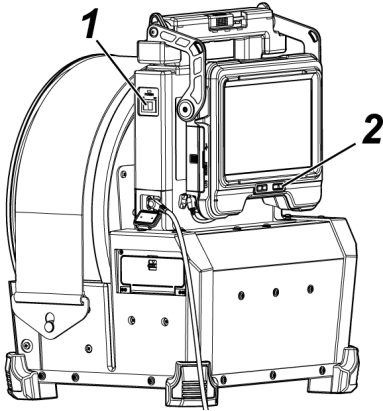

### 2. Press the [POWER] button (⏻) on the base unit for approx. 1.5 to 2 seconds.

The [POWER]LED on the drum unit turns ON in blue and the power of the system turns ON.

The screen display and menu operations become enabled approx. 10 seconds after the [POWER] button (⏻) is pressed.

When the power is turned ON, a list of optical adapters is displayed.



### 3. Select the optical adapter to use, and press the [MEAS/ENTER] joystick.

The setup is complete.

# Nomenclature and functions

Live screen

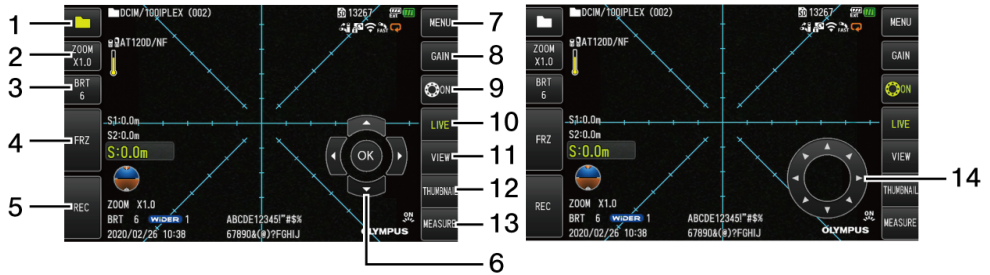

●When [ANGLE] button is ON

No.	Button name	Function
1	[FOLDER]	Shows or hides the [MEAS/ENTER] button (No.6)
2	[ZOOM]	Shows or hides the zoom level buttons (T, W)
3	[BRT]	Shows or hides the brightness level buttons (+, -)
4	[FRZ]/[STOP]	Switches between the live image and frozen image Stops recording when recording the movie
5	[REC]/[CAPTURE]	[REC] Records the still image (short-press) and the movie (long-press) on the live screen Records still image (short-press) on the freeze screen [CAPTURE] Records the still image when recording the movie
6	[MEAS/ENTER]	Switches between folders
7	[MENU]	Displays the different menus
8	[GAIN]	Switches the gain mode
9	[ANGLE/INDEX]	Shows or hides the angulation operation button (No.14) Tapping the button each time repeats switching the angulation operation button to Show, Move or Hide. Adds index mark when recording the movie
10	[LIVE]	Moves to the live screen when in the freeze screen mode
11	[VIEW]	Moves to the view screen
12	[THUMBNAIL]	Moves to the thumbnail screen
13	[MEASURE]	Moves to the scaler measurement screen
14	Angulation operation	Perform the angulation operation

## Performing the angulation operation

1. Press the ANGLE button to display the angulation operation button.
2. Press the angulation operation button of the desired direction for observation.

## Recording images

If you use the SDHC card for the first time, be sure to format the SDHC card using this instrument before recording images. For detail procedures, refer to IPLEX GAir instruction manual.

### **Recording the still image**

1. Short-pressing the [FRZ] button while the live screen is displayed allows you to freeze the image.
2. Short-pressing the [REC] button while the freeze screen is displayed allows you to save the image in the folder.

### **Recording the movie**

1. While the live screen is displayed, long-press the [REC] button.
2. After a still image is recorded, the movie recording confirmation dialog appears.
3. Select <YES>, and start recording the movie.
4. Short-press the [REC] button to end recording the movie.

### **Playing back the recorded image**

View screen

1. Short-press the [VIEW] button to display the latest recorded image.
2. Operate the [MEAS/ENTER] joystick to right or left to switch the image.

Thumbnail screen

1. Short-press the [THUMBNAIL] button to display the thumbnail screen.
2. Operate the [MEAS/ENTER] joystick to four directions to select the image, and press the [OK] button to display the view screen.

# LCD monitor nomenclature

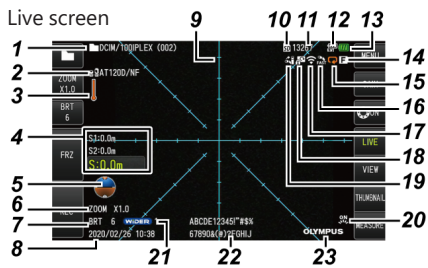

Freeze screen



Thumbnail screen

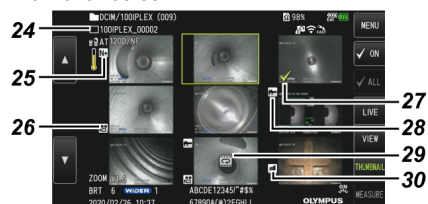

View screen



No.	Icon/Indicator	Name
1	-	Folder name
2	-	Optical adapter name
3		Distal end temperature indicator
4	-	Insertion length information
5		Gravity direction icon
6	-	Zoom level
7	-	Brightness level







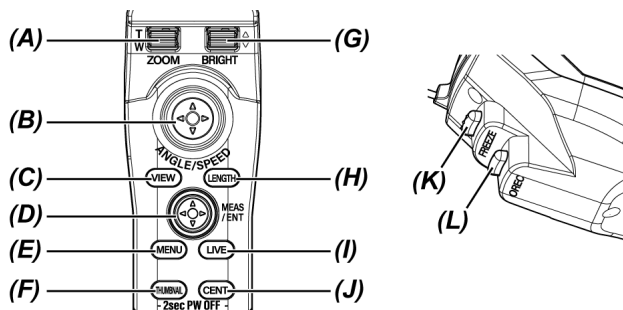

No.	Icon/Indicator	Name
8	-	Date/Time
9	-	Grid
10		SD card icon
11	-	Number of images that can be recorded*1
12		External battery indicator
13		Battery indicator
14		Freeze icon
15		Constant video recording icon
		Recording movie icon
		Recording sound icon
16		Angulation speed icon
17		Wireless LAN icon
18		Image rotation stop icon
19		Angle centering icon
20		LED icon
21		Gain mode icon
22	-	Title
23	-	Logo
24	-	File name
25		Note icon
26		Movie icon
31		Check mark icon
		Measurement icon
		Constant video icon
30		Sound icon
31		Play movie icon
		Pause movie icon
		End movie playback icon
32	-	Movie playback time
33	-	Movie playback position bar
34	-	Index mark
35	-	Total movie duration





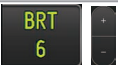

# Operating the product using the remote control unit



	Buttons, Levers and Joysticks	Function	Touch panel
(A)	[ZOOM] lever	Uses the zoom function.	
		Skips (backward and forward) to the index mark positions when playing back or pausing a movie on the view screen.	
(B)	[ANGLE/SPEED] joystick (press)	Switches the angulation speed of the distal end of the insertion tube.	-
	[ANGLE/SPEED] joystick (joystick operation)	Operates the angulation of the distal end of the insertion tube.	
(C)	[VIEW] button	Displays the view screen when there is a still image file in the selected folder. (Tapping this button while the view screen is displayed will show the live screen.)	
	[VIEW] button (long-press)	Switches the illumination in the order of turning ON (high beam), normal beam (eco) and turning OFF.	-
(D)	[MEAS/ENTER] joystick (press the button)	Selects the menu, etc.	-
		Decides the specified point on the measurement screen.	-
		Decides the layout of the note information on the note display screen.	-
		Adds the index marks while recording the movie.	
		Displays the scaler measurement screen.	
		Pressing this button while playing back the movie on the view screen will pause or resume playing back the movie.	-
	[MEAS/ENTER] joystick (joystick operation)	Selects a menu. Switches the selected image on the thumbnail screen.	Tap on the screen

	Buttons, Levers and Joysticks	Function	Touch panel
		Switches a destination folder to save the image on the live screen. Moves the cursor or note information.	
		Displays the previous image by operating this joystick to the left and displays the next image by operating this joystick to the right on the view screen.	
		When playing back the movie on the view screen, operating the joystick upward (downward) allows to perform fast forward (fast reverse) respectively	
(E)	[MENU] button	Shows or hides the menu screen.	
		Pressing this button while displaying the constant video playback screen or the note display screen switches the touch panel monitor display between "Operating with the touch panel and the [MEAS/ENTER] joystick" and "Operating with only the touch panel".	-
(F)	[THUMBNAIL] button	Displays the thumbnail screen. (Tapping this button while the thumbnail screen is displayed will show the live screen.)	
(G)	[BRIGHT] lever	Changes the brightness setting.	
		Adjusts the sound volume on the view screen or the constant video playback screen.	
		On the thumbnail screen, operating this lever upward shows or hides the mark (✓) of the selected thumbnail image. Operating this lever downward shows or hides the mark (✓) of all thumbnail images.	-
(H)	[LENGTH] button (short-press)	Shows the length setting dialog.	
	[LENGTH] button (long-press)	Switches the rotation mode according to the gravity direction of the live image.	Tap the center of the live screen.
(I)	[LIVE] button (except live screen)	Displays the live screen.	
	[LIVE] button (live screen)	Switches the gain mode.	

	Buttons, Levers and Joysticks	Function	Touch panel
(J)	[CENT] button	Centers the distal end of the insertion tube.	Tap the center of the screen when the angulation operation button is displayed.
(K)	[FREEZE] button	Freezes or unfreezes the observation image. Records a still image when movie recording is in progress.	
(L)	[RECORD] button (short-press)	Records a still image. Ends recording the sound during sound recording. Ends recording the movie during movie recording.	
	[RECORD] button (long-press)	Starts recording the movie.	
(E) (I)	[MENU] button + + [LIVE] button (press at the same time)	Turns ON or OFF the LCD monitor. Even while the LCD monitor is turned OFF, the constant video is recorded. When you turn ON the power again, the live screen is displayed.	-
(F) (J)	[THUMBNAIL] + button + [CENT] button (press for 2 seconds or more at the same time)	Turns OFF the base unit.	-
-	-	Switches the folder.	
-	-	Shows, moves or hides the [CURSOR/OK] button.	

**TIP:**





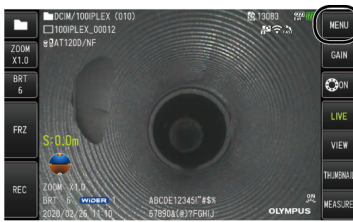

If multiple functions are assigned to the button, the time to press the button distinguishes each function. In this manual, the term “press” or “short-press” is used to indicate pressing a button for a short duration, while “long-press” means holding down a button approx. one second.







## Displaying the menu screen





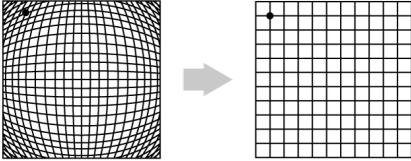

Press the [MENU] button on the LCD monitor to display the menu screen.

















## Using the live screen or freeze screen

Mainmenu	Submenu	Item
<TITLE> 	-	<b>Inputs a title.</b> Puts a title on the live screen and recorded images. Up to 30 characters can be input.
<WHITE BALANCE> 	-	<b>Adjusts the white balance (Live screen only).</b> Specifies whether to adjust the white balance or not. <ul style="list-style-type: none"> <li>&lt;CANCEL&gt;: Do not adjust</li> <li>&lt;EXECUTE&gt;: Adjust</li> </ul> When replacing the parts like the optical adapter, adjust the white balance by acquiring an image of a white object such as a piece of paper, from a distance of 50 to 60 mm. This option cannot be used for the freeze screen.
<IMAGE MODE> 	<IMAGE INVERSION> 	<b>Inverts the live image.</b> You can invert the live image displayed on the LCD monitor. The available options are <OFF>, <HORIZONTALLY REVERSE>, <VERTICALLY REVERSE> and <ROTATE>. This option cannot be used for the freeze screen.
	<SHARPNESS> 	<b>Adjusts the sharpness of the image</b> The sharpness level increases from left to right (4 levels). This option cannot be used for the freeze screen.
	<SATURATION> 	<b>Adjusts the color of the image</b> <ul style="list-style-type: none"> <li>&lt;MONOTONE&gt;: Displays the image in monochrome.</li> <li>&lt;NATURAL&gt;: Displays the standard observed image.</li> <li>&lt;VIVID&gt;: Emphasizes the entire image.</li> </ul> This option cannot be used for the freeze screen.
	<DYNAMIC NOISE REDUCTION> 	<b>Makes the settings for the dynamic noise reduction.</b> You can specify whether to enable or disable the dynamic noise reduction. <ul style="list-style-type: none"> <li>&lt;OFF&gt; : Disable</li> <li>&lt;ON&gt; : Enable</li> </ul> This option cannot be used for the freeze screen.



Mainmenu	Submenu	Item
	<IMAGE ORIENTATION> 	<p><b>Rotates the live image in gravity direction.</b></p> <p>You can select &lt; OFF&gt;, &lt;AUTO-ORIENTATE&gt;, or &lt;ZOOM-ORIENTATE&gt;.</p> <p>See "Rotating the live images automatically"(page 19).</p> <p>This option cannot be used for the freeze screen.</p> <p>This option cannot be used when the side-view optical adapter is used.</p>
	<DISTORTION CORRECTION MODE> 	<p><b>Corrects the distortion of the image.</b></p> <p>You can specify the method to correct the distortion of the image so that it looks like a flat surface.</p>  <p>When using the optical adapter 220D:</p> <ul style="list-style-type: none"> <li>• &lt;OFF&gt; : Disable</li> <li>• &lt;DEWARP220&gt;: Corrects the distortion shrunk outward. (Correction range: 220-degree field of view)</li> <li>• &lt;DEWARP180&gt;: Corrects the distortion shrunk outward. (Correction range: 180-degree field of view)</li> <li>• &lt;DEWARP120&gt;: Corrects the distortion shrunk outward. (Correction range: 120-degree field of view)</li> </ul> <p>When using the optical adapter other than 220D:</p> <ul style="list-style-type: none"> <li>• &lt;OFF&gt; : Disable</li> <li>• &lt;DEWARP120&gt;: Corrects the distortion of the entire image.</li> <li>• &lt;SIDE STRETCH LOW&gt;: Softly corrects the distortion shrunk outward.</li> <li>• &lt;SIDE STRETCH HIGH&gt;: Strongly corrects the distortion shrunk outward.</li> </ul> <p>This option cannot be used for the freeze screen.</p> <p>This option cannot be used if any optical adapter is not selected.</p>
	<GRID> 	<p><b>Displays the grid on the screen.</b></p> <p>You can select the grid view from OFF or three grid types.</p> <p>The grid is displayed on the live screen.</p>
<RECORD MODE> 	<FILE NAME MARK> 	<p><b>Automatically adds a file mark to the end of the file name of the recorded image.</b></p> <ul style="list-style-type: none"> <li>• &lt;OFF&gt;: The mark is not added.</li> <li>• &lt;ON&gt;: The mark is added.</li> </ul> <p>You can select the mark to be added when recording the image. The marks can be selected from None, _A, _B, _C and _D.</p>

Mainmenu	Submenu	Item
	<SD FORMAT> 	<b>Formats (initializes) the SDHC card.</b> <ul style="list-style-type: none"> <li>• &lt;CANCEL&gt;: Does not format the SDHC card.</li> <li>• &lt;EXECUTE&gt;: Formats the SDHC card.</li> </ul> <hr/> <b>⚠ CAUTION:</b> Never remove the SDHC card while formatting the SDHC. <hr/> <b>TIP:</b> Formatting the SDHC card deletes all data. <hr/>
	<microSD FORMAT> 	<b>Formats (initializes) the microSDHC card.</b> <ul style="list-style-type: none"> <li>• &lt;CANCEL&gt;: Does not format the microSDHC card.</li> <li>• &lt;EXECUTE&gt;: Formats the microSDHC card.</li> </ul> <hr/> <b>⚠ CAUTION:</b> Never remove the microSDHC card while formatting the microSDHC card. <hr/> <b>TIP:</b> Formatting the microSDHC card deletes all data. <hr/>
	<MOVIE FRAME RATE> 	<b>Select the frame rate for movie recording.</b> <ul style="list-style-type: none"> <li>• &lt;30 Frames/Sec&gt;</li> <li>• &lt;60 Frames/Sec&gt;</li> </ul>
	<STILL AUDIO> 	<b>Makes settings for sound recording.</b> You can specify whether to record the sound while recording the still image or the movie. A headset is required for recording the sound. <ul style="list-style-type: none"> <li>• &lt;OFF&gt;: Disable</li> <li>• &lt;ON&gt;: Enable</li> </ul> <hr/> <b>⚠ CAUTION:</b> Even though <STILL AUDIO> is set to <ON>, the sound will not be recorded if a headset is not connected. <hr/>
	<CONSTANT VIDEO> 	<b>Make settings for constant video recording.</b> You can specify whether to record the constant video or not while the live screen is displayed. <ul style="list-style-type: none"> <li>• &lt;OFF&gt;: Disable</li> <li>• &lt;ON&gt;: Enable</li> </ul>
<SYSTEM SETUP> 	<DISPLAY> 	<b>Selects the information to be displayed on the screen.</b> You can select whether to display the zoom, brightness, date/time, title, logo, optical adapter, insertion length and gravity direction.

Mainmenu	Submenu	Item
	<DATE TIME> 	<b>Specifies date and time.</b> You can specify date and time.
	<LANGUAGE> 	<b>Specifies the display language.</b> You can select the language used for menus and messages. English and other languages are supported. The default setting is English.
	<VERSION> 	<b>Displays the version information.</b> You can display the software version of the base unit, initial data version and the upgrade information of the system.
	<START UP> 	<b>Saves the settings when the power was turned OFF.</b> By saving the settings when the power was turned OFF, you can specify whether to automatically apply such settings or not when the power is turned ON next time. <ul style="list-style-type: none"> <li>• &lt;OFF&gt;: Disable. (Applies the default settings when the power is turned ON next time.)</li> <li>• &lt;ON&gt;: Saves the settings when the power was turned OFF, and applies such settings when the power is turned ON next time.</li> </ul> (Settings that can be saved: Brightness adjustment, zoom factor, gain mode, and high beam or normal beam (eco))
	<LCD BACKLIGHT> 	<b>Specifies the brightness of the back light of the LCD monitor.</b> The brightness level increases from bottom to top (5 levels).
	<ANGLE SPEED> 	<b>Specifies the angulation speed.</b> The angulation speed can be selected between <SLOW> and <FAST> (2 levels).
	<LENGTH UNIT> 	<b>Selects the unit of insertion length.</b> You can select <meter> or <foot/inch>.
	<LENGTH FORM> 	<b>Selects the method to display the insertion length.</b> You can select <SECTION LENGTH> or <COMBINED LENGTH>. See "Displaying the insertion length"(page 21).
	<CLEAR DRAIN ERROR> 	<b>Clears the drain error of the compressor.</b> This option cannot be used if there is no drain error when you turn ON the power of this instrument or after the drain error is cleared.







Mainmenu	Submenu	Item
	<REMOTE CONTROLLER VIBRATION> 	<p><b>Sets the vibration of the remote control unit.</b></p> <p>You can set whether to vibrate the remote control unit or not in the following cases.</p> <ul style="list-style-type: none"> <li>○ When the insertion tube is pulled out from the inspection object keeping the distal end of the insertion tube bent. (When &lt;SCOPE PROTECTION&gt; is set to &lt;ON&gt;.)</li> </ul> <hr/> <p><b>TIP:</b></p> <p>When the drum unit is rotated in the winding direction, the remote control unit vibrates.</p> <hr/> <ul style="list-style-type: none"> <li>○ When an error occurs.</li> <li>○ When the rotation of the live image according to the gravity direction becomes disabled during angulation operation.</li> <li>○ When the remote control unit is connected.</li> <li>○ When the power of the base unit is turned OFF using the remote control unit.</li> </ul> <p>This option cannot be used when the remote control unit is not connected.</p>
	<SCOPE PROTECTION> 	<p><b>Displays the error message when the insertion tube is pulled out from the inspection object keeping the distal end of the insertion tube bent.</b></p> <p>You can set whether to display the message and to vibrate the remote control unit when the insertion tube is pulled out from the inspection object keeping the distal end of the insertion tube bent.</p> <hr/> <p><b>TIP:</b></p> <p>When the drum unit is rotated in the winding direction, the error message appears.</p> <hr/> <p>See "Detecting when pulling out the bent angulation section"(page 23).</p>
<WIRELESS MODE> 	<CONNECT> 	<p><b>Specifies the wireless communication.</b></p> <ul style="list-style-type: none"> <li>• &lt;OFF&gt;: Disable</li> <li>• &lt;ON&gt;: Enable</li> </ul>
	<DEFAULT> 	<p><b>Initializes the wireless settings.</b></p> <ul style="list-style-type: none"> <li>• &lt;CANCEL&gt;: Does not format the wireless settings.</li> <li>• &lt;EXECUTE&gt;: Formats the wireless settings.</li> </ul>
<PLAY CONSTANT VIDEO> 	-	<p><b>Plays back the constant video.</b></p> <p>Plays back the constant videos automatically if there are recorded constant videos.</p>





Mainmenu	Submenu	Item
<SELECT OPTICAL ADAPTER> 	-	<b>Displays the optical adapter list.</b> You can set the optical adapter that is connected to the system. This option cannot be used for the freeze screen.
<ROTATE> 	-	<b>Displays the screen by rotating it 180 degrees.</b> You can display the screen of the LCD monitor by rotating it 180 degrees. To return to the original state, select <OFF> in the <ROTATE> menu.

## Using the thumbnail screen or the view screen

You can make the following settings in the menu displayed on the thumbnail screen.

Menu	Available settings
<DELETE> 	<b>Deletes the recorded image.</b> <ul style="list-style-type: none"> <li>• &lt;CANCEL&gt;: Do not delete the image.</li> <li>• &lt;EXECUTE&gt;: Delete the image.</li> </ul> You can delete the images selected on the thumbnail screen or images with the mark (✓).
<MOVE FILE> 	<b>Moves image files from one folder to another.</b> You can move the recorded images to a different folder. The images currently selected on the thumbnail screen or images with the mark (✓) are moved.
<RENAME FILE> 	<b>Changes the image file name.</b> You can change the name of the recorded image file (30 characters or less).
<CHANGE FOLDER> 	<b>Switches between the folder for recording and the folder playing back the image.</b> You can switch between the folder for recording and the folder for playing back the image. The default setting is "DCIM\100IPILEX". You can change to the folder displayed on the menu screen.
<MAKE FOLDER> 	<b>Creates a new folder for recording and playing back the image.</b> You can create a folder for recording and playing back the image. Up to 1,000 folders can be created in one folder.
<RENAME FOLDER> 	<b>Renames a folder for recording and playing back the image.</b> You can rename a folder for recording and playing back the image.

The following settings can be made on the view screen menu.

Menu	Available settings
<p>&lt;DELETE&gt;</p> 	<p><b>Deletes the recorded image.</b></p> <ul style="list-style-type: none"> <li>• &lt;CANCEL&gt;: Do not delete the image.</li> <li>• &lt;EXECUTE&gt;: Delete the image.</li> </ul> <p>You can delete the image displayed on the view screen.</p>
<p>&lt;NOTE&gt;</p> 	<p><b>Inputs the note information (text/mark/free drawing) to the desired position on the screen (view screen for still image only).</b></p> <p>You can input the note information (text/mark/free drawing) on the still image that is being played back.</p>

## Inputting a title

Inputting a title using the software keyboard



**1. Select the input mode.**

**2. Select the text buttons you want.**

**To delete texts**

- To delete a single text, move the cursor to it and select <DELETE>.
- To delete all input texts, select <CLEAR>.

**To input a space**

Move the cursor to the location where you want to input the space, and select <SPACE>.

**3. Select <EXECUTE>.**

The title you input is displayed on the live screen and the freeze screen.

Inputting a title by selecting a preset title



### 1. Select <PRESET>.

A list of preset titles is displayed. To cancel selecting the preset title, press the close button (x) to close the screen.

### 2. Select the text strings from the preset title list.

The text string you selected appears in the title field and the list is closed.

Repeat steps **1** and **2** to complete inputting the title.

---

**TIP:**

The preset title list has nine pages. To change pages, select the text string in line 1 or line 6 of the list and operate the [MEAS/ENTER] joystick upward or downward, or press the up button or the down button on the right side of the screen.

---

### 3. Select <EXECUTE>.

The title you selected is displayed on the live screen and the freeze screen.

## Displaying the gravity direction

Using the acceleration sensor built in the distal end of the insertion tube, you can display the gravity direction on the live screen according to the tilt or rotation of the distal end of the insertion tube.



The gravity direction icon expresses the surface that is cut vertically against the inserting direction of the distal end of the insertion tube. The brown area indicates the ground side (gravity direction) and the blue area indicates the sky side (direction opposite to gravity).

The white circle in the icon indicates the center of the ground side (gravity direction) and the red circle indicates the center of the sky side (direction opposite to gravity).

---



**TIP:**

- The gravity direction icon is displayed when using the forward-view optical adapter.
  - You can show or hide the gravity direction icon by selecting the menu - <SYSTEM SETUP> - <DISPLAY>.
- 

## Rotating the live images automatically

Using the acceleration sensor built in the distal end of the insertion tube, you can display the live image by rotating it so that the downward direction of the image always indicates the gravity direction.

There are two methods to rotate the image as shown below.

<p>&lt;AUTO-ORIENTATE&gt;</p> 	<p>Rotates the live image according to the gravity direction. The displayed image contains the area without data (black area in the picture on the left).</p>
<p>&lt;ZOOM-ORIENTATE&gt;</p> 	<p>Rotates the live image according to the gravity direction, and displays the image by zooming digitally so that the area without data will not be contained.</p> <hr/> <p><b>TIP:</b> The image may become slightly coarse due to digital zoom.</p>

Tapping on the live screen switches in the order of <AUTO-ORIENTATE>, <ZOOM-ORIENTATE> and <OFF>.

**TIP:**

- The rotation mode of the live image can also be changed on the <IMAGE ORIENTATION> menu.
- The rotation mode of the live image can also be changed by long-pressing the [LENGTH] button on the remote control unit.
- In <AUTO-ORIENTATE> or <ZOOM-ORIENTATE> mode, when the insertion tube is bent in proximity of the gravity direction or the direction opposite to gravity, the automatic rotation of the live image stops. At this time, the image rotation stop icon (⏸) appears on the live screen, and if the <REMOTE CONTROLLER VIBRATION> menu is set to <ON>, the remote control unit vibrates.
- Display the angulation operation button on the LCD monitor and then tap the center of the screen, or press the [CENT] button on the remote control unit to automatically rotate the live image again.

## Displaying the insertion length

You can display the insertion length information how long the distal end of the insertion tube is inserted into the observation object on the live image or the recorded image.

The insertion length is measured by the rotation of the drum unit.

The insertion direction is displayed by the + direction and the pulling out direction by the - direction respectively with the position when the system is turned ON or the position where the insertion length is reset as a reference point.

In addition, up to two passing points can be added to the current positions.

The formats or units for displaying the insertion length are shown below.

<LENGTH FORM>	<SECTION LENGTH> Displays the length from the reference point or the passing point.
	<COMBINED LENGTH> Always displays the length from the reference point.
<LENGTH UNIT>	<meter> Example: 30.0 m
	<foot/inch> Example: 98'5"

You can set the above on the <LENGTH FORM> menu or the <LENGTH UNIT> menu.

### TIP:

You can show or hide the insertion length by selecting the menu - <SYSTEM SETUP> - <DISPLAY>.

The reference point and the passing points are set in the insertion length setting dialog. The insertion length setting dialog can be displayed by pressing the insertion length displayed on the live image.

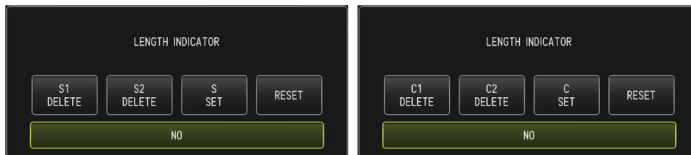

### TIP:

The insertion length setting dialog can also be displayed by pressing the [LENGTH] button on the remote control unit.

Example 1

With the pipe as shown below, assume the case to start observation from the position A, set the elbows B and C as the passing points, and observe up to the position D.

The insertion length information (in meter) for each position is shown below.

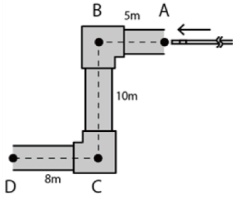

1. Turn ON the power of the system at the position A.

(Or tap <RESET> at the position A.)

<SECTION LENGTH>	<COMBINED LENGTH>
S: 0.0 m	C: 0.0 m

2. Display at the position 2 m to the left from the position A

<SECTION LENGTH>	<COMBINED LENGTH>
S: 2.0 m	C: 2.0 m

3. Tap <S SET> or <C SET> at the position B.

<SECTION LENGTH>	<COMBINED LENGTH>
S1: 5.0 m	C1: 5.0 m
S: 0.0 m	C: 5.0 m

4. Display at the position 3 m below the position B

<SECTION LENGTH>	<COMBINED LENGTH>
S1: 5.0 m	C1: 5.0 m
S: 3.0 m	C: 8.0 m

5. Tap <S SET> or <C SET> at the position C.

<SECTION LENGTH>	<COMBINED LENGTH>
S1: 5.0 m	C1: 5.0 m
S2: 10.0 m	C2: 15.0 m
S: 0.0 m	C: 15.0 m

6. Display at the position D

<SECTION LENGTH>	<COMBINED LENGTH>
S1: 5.0 m	C1: 5.0 m
S2: 10.0 m	C2: 15.0 m
S: 8.0 m	C: 23.0 m

## Example 2

With the same pipe used in Example 1, the displays when setting the passing points at elbows and clearing each passing point are shown below.

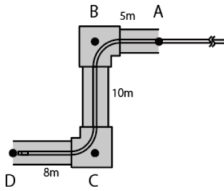

Tapping <S2 DELETE> or <C2 DELETE> at the position D will delete the information of the passing point C that was set second.

<SECTION LENGTH>	<COMBINED LENGTH>
S1: 5.0 m	C1: 5.0 m
S2: 10.0 m	C2: 15.0 m
S: 8.0 m	C: 23.0 m

➔

<SECTION LENGTH>	<COMBINED LENGTH>
S1: 5.0 m	C1: 5.0 m
S: 18.0 m	C: 23.0 m

Tapping <S1 DELETE> or <C1 DELETE> at the position D will delete the information of the passing point B that was set first and display the information of the passing point C at S1 or C1.

<SECTION LENGTH>	<COMBINED LENGTH>
S1: 5.0 m	C1: 5.0 m
S2: 10.0 m	C2: 15.0 m
S: 8.0 m	C: 23.0 m

➔

<SECTION LENGTH>	<COMBINED LENGTH>
S1: 15.0 m	C1: 15.0 m
S: 8.0 m	C: 23.0 m

Tapping <RESET> at the position D will delete the passing points and the reference point, and display the position D as a new reference point.

<SECTION LENGTH>	<COMBINED LENGTH>
S1: 5.0 m	C1: 5.0 m
S2: 10.0 m	C2: 15.0 m
S: 8.0 m	C: 23.0 m

➔

<SECTION LENGTH>	<COMBINED LENGTH>
S: 0.0 m	C: 0.0 m

## Detecting when pulling out the bent angulation section

When the insertion tube is pulled out from the inspection object while the angulation section is bent, the message appears or the remote control unit vibrates.

### TIP:

When the drum unit is rotated in the winding direction, it is detected that the insertion tube is pulled out while the angulation section is bent.

1. Display <SCOPE PROTECTION> in the <SYSTEM SETUP> menu on the live screen.
2. Select <ON>.

**NOTE:**

- If the following message appears during inspection, display the angulation operation button on the LCD monitor and tap the center of the screen to center the distal end, or press the [CENT] button on the remote control unit to center the distal end.
  - <PLEASE CENTER THE DISTAL END BY PRESSING THE CENTER BUTTON.>
- If you want to vibrate the remote control unit at the same time when the message appears, set the <REMOTE CONTROLLER VIBRATION> menu to <ON>.

## Scaler measurement

Scaler measurement measures the length of an object using the reference length value that is preset according to a known length inside the observation image.

1. Attach an optical adapter, and select the optical adapter using the menu. Check the IPLEX GAir instruction manual for an optical adapter that can be used.
2. While the image you want to measure is displayed, press the [MEAS/ENTER] joystick to start scaler measurement.
3. Follow the instructions in the message box to perform the following operations and obtain the measurement values.
  1. Specify the reference point.
 

Align the cursor with one end of the object of which length is known and press the [MEAS/ENTER] joystick, and then, align the cursor with the other end and press the [MEAS/ENTER] joystick.
  2. Input the reference length.
 

Input the known length by operating the [MEAS/ENTER] joystick up/down/left/right.
  3. Specify the measuring point.
 

Align the cursor with one end of the object you want to measure and press the [MEAS/ENTER] joystick, and then align the cursor with the other end and press the [MEAS/ENTER] joystick

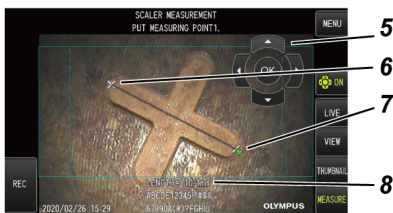
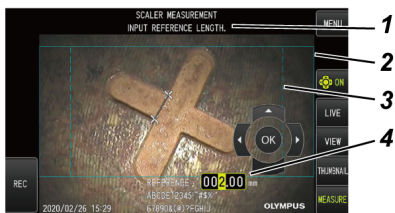









No.	Name	Function
1	Message box	Displays information related to operation.
2	Measurable region	Displays the measurable region with solid line.



No.	Name	Function
3	Recommended measurement region	Displays the recommended measurement region with dotted line.
4	Reference length	Inputs the dimensions of the parts of which length is known.
5	[CURSOR/OK] button	Operates the cursor and inputs the reference length on the screen.
6	Point	Reference point or measuring point that has been input
7	Cursor	Specifies the reference point or measuring point.
8	Measurement value	Displays the measurement result of the input points.

### Scaler measurement menu and functions



Menu	Description
<CLEAR> 	Clears the measuring point or reference point that is specified last
<REFERENCE> 	Sets a new reference length again.
<MEASURE> 	Starts the scaler measurement (specify measuring points) using the reference length.
<UNIT> 	Selects the unit for the measurement You can select <mm> or <inch>.
<CURSOR> 	Selects a cursor shape. You can select  or  .
<EXIT MEASUREMENT> 	Exits the scaler measurement.

## Symbols used in this instruction manual

The following symbols are used throughout this instruction manual.

### DANGER:

Indicates an imminently hazardous situation which, if not avoided, will result in death, serious injury or damage of inspection object.

---

**⚠WARNING:**

Indicates a potentially hazardous situation which, if not avoided, could result in death, serious injury or damage of inspection object.

---

---

**⚠CAUTION:**

Indicates a potentially hazardous situation which, if not avoided may result in minor or moderate injury or potential material damage. It may also be used to alert against unsafe practices or potential material damage.

---

---

**NOTE:**

Indicates a potential situation which, if not avoided, may result in failure of this instrument.

---

---

**TIP:**

Indicates additional helpful information.

---

---

## Safety precautions - General safety precautions -

Comply strictly with the precautions described below when handling this instrument. The information is supplemented by dangers, warnings and cautions given in each chapter. The safety cannot be ensured when the instrument is used in ways that are not specifically described.

---

**⚠DANGER:**

**Never use the instrument for observing inside of the human or animal cavity.**

Otherwise, death or the serious injury of the person or animal may result.

**Never use the instrument in the following environments.**

- Where flammable atmospheres are present
- Where metal dust or other dust is present

Otherwise, an explosion or fire may result.

---

**⚠WARNING:**

**Do not repair, disassemble or remodel the instrument.**

Never repair, disassemble or remodel the instrument. Otherwise, the injury of human bodies or the damage of the instrument may result. Only personnel who are authorized by us are allowed to repair the instrument. We are not liable for any accidents or instrument damage that occurs as a result of repairs attempted by personnel who are not authorized by us.

**Stop using the instrument immediately at the first sign of heat, smoke, abnormal odor, abnormal noise or any other abnormality.**

Even if the instrument is still operable, turn OFF the power.

**Do not insert the insertion tube into an inspection object that is in operation or conducting electricity.**

Otherwise, the insertion tube may be damaged by being caught inside of the inspection object, etc., or the insertion tube may touch the object, which results in electric shock.

**Before storing the instrument in its carrying case, be sure to turn OFF the power and remove the battery and/or the external battery.**

Leaving the battery and/or the external battery loaded during storage causes it to be hot, which may cause fire.

---

**⚠WARNING:**

**The gas tube must not be used for grounding.**

Otherwise, it may cause an explosion.

---

**⚠CAUTION:**

**Do not use the instrument in any environment (including strongly radioactive environments) other than the specified operating environment.**

Using the instrument even in weakly radioactive environment may deteriorate the performance of the instrument.

For the influence of the radiation dosage given to the instrument, contact us.

**Do not use this instrument near the strong electromagnetic radiation source.**

The proper operations may be interfered. Check the electromagnetic environment before using this instrument.

**Note the following precautions when moving this instrument to or using it at an elevated location.**

- Conduct a prior inspection
- Take measures to prevent the instrument from falling off
- Implement thorough safety measures

**Pay careful attention to the temperature of the distal end and the insertion tube right after using this instrument in high temperature environments as the temperature does not cool down immediately.**

Otherwise, you may get burned.

**Do not touch the edge (A) inside the drum rotator.**

Otherwise, you may get injured by the edge.

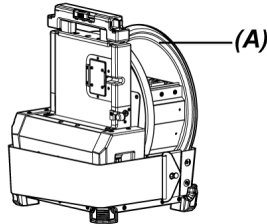

**Do not rotate the drum by holding the parts other than the drum rotation handle.**

Otherwise, you may get injured.

**Pay attention not to trip over the relay cable, power cord or cables of the insertion tube.**

**Do not use commercially-available electronic transformers for overseas travel use (travel converters).**

**Use only the power cord and the AC adapter specified by us and connect the power cord to the power outlet within the rated range.**

Otherwise, smoke, fire, or electric shock may occur.

**Always connect the ground terminal.**

Connect the ground terminal of the power cord and that of the power outlet. If the product is not grounded, our intended electric safety and EMC performance of the product cannot be assured.

**Do not use the power cord specified for this instrument for other products.**

---

**⚠CAUTION:**

**Do not use the AC adapter outdoors.**

Otherwise, electric shock, smoke or fire may occur, which may cause damage to the instrument.

The AC adapter is designed for indoor use.

**Do not apply a strong impact to the AC adapter by hitting it against the wall or dropping it to the floor, etc.**

Otherwise, the malfunction or damage may be caused and result in electric shock.

**If you sense any abnormality while inserting the insertion tube into the inspection object, do not attempt to insert it forcibly any more but carefully pull out the insertion tube.**

Note the following when pulling out the insertion tube.

- Do not pull out the insertion tube from the inspection object while the angulation section is bent.
- If the insertion tube is caught on something during pulling it out, rotate the insertion tube gently while continuing to pull out.

**Note the following precautions when handling the distal end of the insertion tube.**

- Do not drop the optical adapter or subject it to strong impact.
- Do not subject the distal end to severe impact or pulling.
- Do not move by holding the distal end.
- Do not use this instrument if the O-ring of the distal end is damaged or torn.
- Do not subject the angulation section to strong pressure or bending.

Otherwise, the glass lenses and the precision components which constitute the distal end and the angulation section may be damaged.

**Always attach the optical adapter before using this instrument.**

If you use the instrument without attaching the optical adapter to the insertion tube, parts (screws, etc.) are easily deformed due to contact with hard objects, etc. If the insertion tube parts are deformed, the optical adapter cannot be attached or may fall off.

**Never use the optical adapter if any of its parts are loose.**

Otherwise, the loose parts may fall off.

**If the optical adapter cannot be attached or removed because the nut does not rotate, stop using it.**

Contact us.

**⚠CAUTION:**

**If abnormality is found in the observation image, stop using immediately and pull out the insertion tube from the inspection object carefully.**

If the optical adapter is about to fall off from the distal end of the insertion tube while inserting the insertion tube into the inspection object, the illumination turns OFF. (The LED icon (ON/OFF) of the LCD monitor is hidden.)



If the guide head is about to fall off from the distal end of the insertion tube while inserting the insertion tube into the inspection object, a part of the view may be lost.

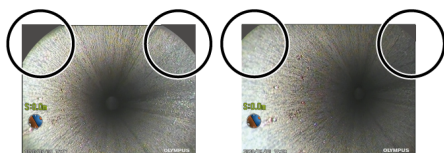

Continued use in this condition may cause the optical adapter or the guide head to fall off from the distal end of the insertion tube. In this case, pull out the insertion tube carefully from the inspection object and attach the optical adapter or the guide head firmly again.

**If you sense any abnormality while performing the angulation operation, do not attempt to force the angulation operation.**

Otherwise, the insertion tube or the inspection object may be damaged.

**Do not allow metal or other foreign objects to enter the product through connector terminals or any other openings.**

Otherwise, the malfunction or electric shock may result.

**Do not use the parts other than the insertion tube underwater, clean them under running water or splash water on them.**

Otherwise, water creates the risk of electric shock. Do not use or store the instrument in an environment where it is submerged in water.

**The remote control unit is a high-sensitivity parts. Discharge it before use.**

Otherwise, the malfunction may be caused due to static electricity, etc.

**Do not subject the LCD monitor to strong impact, strong pressure or to scratching by a hard or pointed object.**

Otherwise, the LCD monitor may be cracked or scratched, or the damaged monitor may cause personal injury.

---

**⚠CAUTION:**

**When pushing down the handle, be careful not to get your hand or other objects caught in between.**

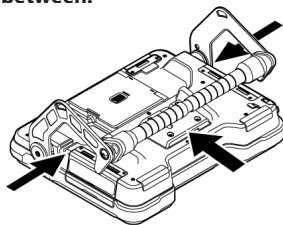

**Use the SDHC card or the microSDHC card to record images.**

This instrument comes with an SDHC card.

**Do not remove the battery or external battery, or AC adapter while accessing to the SDHC card or the microSDHC card.**

Otherwise, the recorded data may be damaged.

**Do not remove the SDHC card or the microSDHC card while recording or replaying the image.**

Otherwise, recorded data, SDHC card or microSDHC card may be damaged.

**Do not repeat inserting or removing the SDHC card or the microSDHC card continuously.**

Otherwise, recorded data, SDHC card or microSDHC card may be damaged or may not function properly.

**Be careful for followings when using the extendable handle of the carrying case.**

- Do not get your hand caught when storing the handle inside the case.
- Do not attempt to lift the case by holding the extendable handle.

---

**NOTE:**

**Do not store the instrument in the following locations.**

- Environments exposed to high temperature, high humidity and large amounts of dust or particulate
- Locations exposed to direct sunlight or radiation
- Locations exposed to gas containing halide\*1

Otherwise, the instrument may be damaged.

**\*1 The performance of some electrical parts may deteriorate due to the halide in insecticides, pesticides and gaseous extinguishing agents, etc.**

**Do not continue to use the instrument when it is wet with condensation.**

In case of a sudden temperature change, such as entering a warm room from cold outside, condensation may be caused inside the instrument. Using the instrument while it is wet with condensation may cause malfunction. If condensation occurs, turn OFF the power, leave the instrument in the environment where it will be used and allow the condensation to dry before using it.

**Do not insert the insertion tube into the inspection object which is in an environment that exceeds the operating temperature range.**

The continued use may damage or deteriorate the performance of the instrument.

**Do not use the instrument if the contaminants are attached to the outer surface of the instrument.**

The instrument may be damaged or the performance may be deteriorated.

**NOTE:**

**Do not cover the product with a plastic bag or other objects.**

The inside of the instrument may not be cooled down sufficiently, which may damage the instrument.

**Do not allow any liquids other than water, saltwater, machine oil or diesel oil to be attached to the insertion tube.**

Otherwise, the insertion tube may be damaged.

**Note the following precautions when handling the battery door, interface door, SD card door and relay cable door.**

- Do not open or close doors when water or other liquid is attached to the relay cable or around doors.
- Do not open or close doors with your wet hands.
- Do not open or close doors in the area exposed to high humidity and/or dust.
- Close doors when storing the instrument and when the terminals are not in use.

**Note the following precautions with regard to the terminals on this instrument.**

- Do not touch the terminals directly with your hands.
- Prevent dirt and water droplets from coming in contact with the terminals.

**Be careful not to allow scattered water droplets to come in contact with the terminals.**

Be careful not to allow scattered water droplets to come in contact with each terminal of the AC adapter, relay cable, drum unit, scope unit or base unit.

Otherwise, the instrument may be damaged.

**Note the following precautions when taking out the instrument from the carrying case and scope case.**

- Do not lift and pull the insertion tube.

The instrument may be damaged.

**Do not pull the insertion tube and other cables with force or carry them around.**

**Note the following precautions when storing this instrument in the carrying case or the scope case.**

- Make sure that the distal end has cooled down sufficiently before storing it.
- Make sure that the insertion tube is not twisted before storing it.

**Do not lift the carrying case or the scope case while the cover is open.**

**Bundle the cable of the remote control unit with the cable tie as shown in the picture below.**

When bundling the cable of the remote control unit, do not wrap the cable around the remote control unit. The excess force may be applied to the cable and it may be damaged.

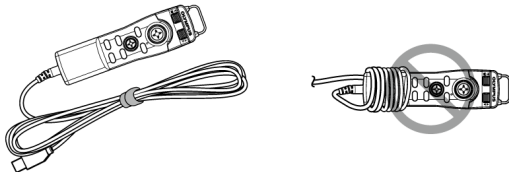

---

**NOTE:****Note the following precautions when using the guide head.**

- Never use the guide head if any of its parts are loose. The loose parts may fall off during operation.
- Do not insert the insertion tube into the locations described below.
  - Location with steps such as outlet or connection part of pipe
  - Location with protrusions
  - Location where you feel too tight to insert the insertion tube
- Keeping in mind that the insertion tube should be pulled out later, do not insert it forcibly. If you insert the insertion tube into the elbow joints or the curved pipe, or insert it forcibly into inspection objects, the insertion tube may not be pulled out.
- If you feel that something is caught while pulling out the insertion tube, do not pull it out forcibly, but pull it out gently by moving it back and forth.

**Note the following precautions when using the push rod adapter.**

- Never use the push rod adapter if any of its parts are loose. The loose parts may fall off during operation.
- Do not insert the insertion tube into the locations described below.
  - Curved pipe
  - Location with steps such as outlet or connection part of pipe
  - Location with T-shape joints, elbow joints or protrusions
  - Location where you feel too tight to insert the insertion tube
- Keeping in mind that the insertion tube should be pulled out later, do not insert it forcibly. If you insert the insertion tube forcibly, the insertion tube may not be pulled out.
- If you feel that something is caught while pulling out the insertion tube, do not pull it out forcibly, but pull it out gently by moving it back and forth.

**Note the following precautions when using the centering device.**

- Never use the centering device if any of its parts are loose. The loose parts may fall off during operation.
- Do not insert the insertion tube into the locations described below.
  - Location with steps such as outlet or connection part of pipe
  - Elbow joints
  - Location inside the pipe with protrusions or the curved pipe where the centering device cannot be inserted
  - Location where you feel too tight to insert the insertion tube
- Keeping in mind that the insertion tube should be pulled out later, do not insert it forcibly. If you insert the insertion tube forcibly, the insertion tube may not be pulled out.
- If you feel that something is caught while pulling out the insertion tube, do not pull it out forcibly, but pull it out gently by moving it back and forth.

**When disposing of this product, be sure to do so in accordance with all local laws, rules and regulations.**

---

## **Safety precautions - Battery precautions -**

If you experience any problems when using this instrument with batteries, contact us.

Comply strictly with the precautions described below when handling the battery. If the batteries are handled improperly, the battery fluid leakage, excessive heat generation, smoke, battery burst, electric shock and/or burns may result.



Before use, thoroughly read the instruction manual provided with the battery charger to fully understand the information contained in them, and observe their instructions during use.

In this manual, the Li-ion battery to be attached to the drum unit is called "Battery", and the Ni-MH battery to be attached to the external battery case is called "External battery".

---

**⚠DANGER:**

**Use the battery NP-9X or NP-L7S and charge the battery using the battery charger JL-2PLUS.**

**Do not subject the battery to strong impact.**

**Do not allow terminals to be short circuited with metal objects.**

In particular, do not store external batteries in the carrying case when transporting the instrument.

**Do not throw the battery into fire or subject it to heat.**

**Do not open or modify the battery.**

**Do not use the battery charger outdoors.**

Otherwise, the electric shock, smoke or fire may occur, which may cause the damage to the battery charger. The battery charger is designed for indoor use.

---

**⚠WARNING:**

**Do not cover the battery charger with clothing, bedding or other materials while charging.**

**When the charging is complete, always unplug the power plug of the battery charger from the power outlet.**

**If you sense heat generation, abnormal odor, abnormal noise, smoke, or any other abnormality in battery charger, unplug the power plug of the battery charger immediately and stop using it.**

Contact us.

**If the battery charger does not complete recharging the battery in the specified recharging time, stop attempting to recharge the battery.**

**Do not allow the battery compartment to become deformed and never put any foreign object into it.**

**Do not allow metal or water, or any other fluid to get into the battery compartment or onto the battery terminals.**

If any foreign object enters the drum unit, remove the battery and disconnect the AC adapter, and immediately contact us.

**Do not remove the battery immediately if the instrument was used continuously for a long time.**

The heat generated by the battery causes the risk of burn injury.

**Do not touch the battery terminals with your wet hands.**

**If you plan not to use the instrument for a long time, remove the battery from the drum unit and store it in a dry place.**

If you do not use the battery, remove it from the drum unit and store it.

Otherwise, the battery fluid may leak and the heat generation may result in a fire or injury.

**Keep the battery out of the reach of small children.**

**If liquid leaking from the battery comes into contact with your body, rinse it off immediately with clean water from the tap, etc. and seek medical attention if necessary.**

---

**⚠CAUTION:**

**If you are experiencing problems in inserting the battery, do not attempt to insert it forcibly.**

Check the orientation of the battery and check the terminals for abnormalities. Attempting to insert the battery forcibly into the compartment may cause malfunction.

**If you are experiencing problems removing the battery from the drum unit, do not attempt to remove it forcibly.**

Contact us.

**Contact the airlines in advance if you plan to transport the battery by aircraft.**

**When replacing the battery, do not repeat inserting or removing it rapidly.**

Otherwise, the power may not be turned ON.

**Do not store the battery in the following locations.**

- Environments exposed to water, high temperature, high humidity, low humidity and dust
- Locations exposed to direct sunlight or radiation
- Locations exposed to gas containing halide\*1

\*1 The performance of some electrical parts may deteriorate due to the halide in insecticides, pesticides and gaseous extinguishing agents, etc.

**Do not use, charge or store the battery in areas exposed to direct sunlight, in a closed automobile in the sun, or near a heater, etc.**

**Do not use a battery if it shows any irregularity such as fluid leakage, discoloration, deformation, abnormal odor or other abnormality.**

**Do not immerse the battery in fresh water or sea water, or allow the battery to get wet.**

**When disposing of a battery, be sure to do so in accordance with all local laws, rules, and regulations.**

---

**NOTE:**

- The contamination of battery terminals with sweat or oil will cause the contact failure. If the battery is dirty, wipe it with a dry cloth before use.
- Use the battery correctly. If the battery is used incorrectly, battery fluid leakage, heat generation or damage may result. Insert the battery in the correct orientation when replacing it.
- The sticker showing "DO NOT USE" is attached on the base unit. Do not peel it off.
- Temperature range for battery operation
  - Discharge (when using this instrument): -15 °C to 48 °C
  - Charging : 0 °C to 40 °C
  - Storage : -20 °C to 60 °C (Recommended: 20 °C)

Using the battery under a temperature exceeding the temperature ranges described above will result in degradation of its performance and service life. Before storing the instrument, be sure to remove the battery from the drum unit.

- The remaining battery level may be different from that of the battery indicator displayed on the LCD monitor depending on operating environments.

---

## Safety precautions - External battery precautions -

If you experience any problems when using this instrument with external batteries, contact us.

Comply strictly with the precautions described below when handling the external battery. If the external batteries are handled improperly, the external battery fluid leakage, excessive heat generation, smoke, battery burst, electric shock and/or burns may result.

Before use, thoroughly read the instruction manual provided with the battery charger to fully understand the information contained in them, and observe their instructions during use.

In this manual, the Li-ion battery to be attached to the drum unit is called "Battery", and the Ni-MH battery to be attached to the external battery case is called "External battery".

---

**⚠DANGER:**

**Use the external battery case MAJ-2485.**

**Use the external battery recommend by us described below.**

- Single shape NiMH battery complied with IEC62133-1
- Temperature range: Sufficiently wider than the temperature range of external battery case (0 °C to 48 °C) is recommended.
- Storage capacity: 10,000 mAh or more is recommended.

Using the NiMH battery other than that described above will result in degradation of its performance and service life.

The performance of the functions may not be fully exercised depending on the external battery.

For recommended external battery, contact us.

**Do not subject the external battery to strong impact.**

**Do not use the battery charger outdoors.**

Otherwise, the electric shock, smoke or fire may occur, which may cause the damage to the battery charger. The battery charger is designed for indoor use.

**Do not throw the external battery into fire or subject it to heat.**

**Do not open or modify the external battery.**

---

**⚠WARNING:**

**Do not cover the battery charger with clothing, bedding or other materials while charging.**

**When the charging is complete, always unplug the power plug of the battery charger from the power outlet.**

**Do not allow the external battery compartment to become deformed and never put any foreign object into it.**

**Do not allow metal or water, or any other fluid to get into the external battery compartment and onto the external battery terminals.**

If any foreign object enters the external battery case, remove the external battery and disconnect the AC adapter, and immediately contact us.

**Do not remove the external battery immediately if the instrument was used continuously for a long time.**

The heat generated by the external battery causes the risk of burn injury.

**Do not touch the external battery terminals with your wet hands.**

**Be careful not to allow the ventilation port (A) of the external battery case to be blocked with dirt or dust.**

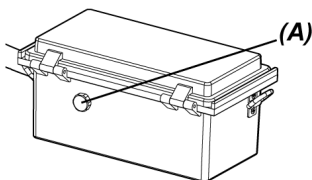

---

**⚠WARNING:**

**If you plan not to use the instrument for a long time, remove the external battery from the external battery case, and store it in a dry place.**

If you do not use the external battery, remove the external battery case from the drum unit, remove the external battery from the case, and store it.

Otherwise, the external battery fluid may leak and the heat generation may result in a fire or injury.

**Keep the external battery out of the reach of small children.**

**If liquid leaking from the external battery comes into contact with your body, rinse it off immediately with clean water from the tap, etc. and seek medical attention if necessary.**

**Do not insert the external battery in the external battery case with wrong polarity (+ or -).**

**Do not insert or take out the external battery while connecting the external battery case to the drum unit.**

**Do not use the external battery if any abnormality such as liquid leakage, etc. is found.**

**Do not use the external battery of a different type for the external battery case.**

**Do not use old batteries together with new batteries, or batteries together with those with different charging states.**

**Do not use the battery other than the external battery such as alkaline battery, manganese battery, etc. for the external battery case.**

---

**⚠CAUTION:**

**If you are experiencing problems in inserting the external battery, do not attempt to insert it forcibly.**

Check the orientation of the external battery and check the terminals for abnormalities. Attempting to insert the external battery forcibly into the compartment may cause malfunction.

**If you are experiencing problems removing the external battery from the external battery case, do not attempt to remove it forcibly.**

Contact us.

**When replacing the external battery, do not repeat inserting or removing it rapidly.**

Otherwise, the power may not be turned ON.

**Do not store the external battery in the following locations.**

- Environments exposed to water, high temperature, high humidity, low humidity and dust
- Locations exposed to direct sunlight or radiation
- Locations exposed to gas containing halide\*1

\*1 The performance of some electrical parts may deteriorate due to the halide in insecticides, pesticides and gaseous extinguishing agents, etc.

**Do not use, charge or store the external battery in areas exposed to direct sunlight, in a closed automobile in the sun, or near a heater, etc.**

**Do not use the external battery if it shows any irregularity such as fluid leakage, discoloration, deformation, abnormal odor or other abnormality.**

**Do not immerse the external battery in fresh water or sea water, or allow the external battery to get wet.**

---

**⚠CAUTION:****Note the following when replacing the fuse of the external battery case.**

- Do not touch the fuse with your wet hands.
- Remove the external battery case from the drum unit carefully.
- Remove the external battery from the external battery case carefully.
- Use the specified fuse.

Otherwise, the electric shock may be caused.

**When disposing of an external battery, be sure to do so in accordance with all local laws, rules, and regulations.**

---

**NOTE:**

- The contamination of external battery terminals with sweat or oil will cause the contact failure. If the external battery is dirty, wipe it with a dry cloth before use.
  - Use the external battery correctly. If the external battery is used incorrectly, external battery fluid leakage, heat generation or damage may result. Insert the external battery in the correct orientation when replacing it.
  - When recharging the external battery, recharge it fully. Otherwise, the performance of the external battery may not be fully exercised.
  - Before transporting the instrument, be sure to store the external battery in the external battery case.
  - It is recommended to contact the airlines in advance if you plan to transport the external battery.
  - When transporting the instrument, DO NOT store external batteries in the external battery case. Otherwise, the external battery case may be damaged.
  - The remaining external battery level may be different from that of the battery indicator displayed on the LCD monitor depending on the makers or operating temperature environments.
- 

## Safety precautions - Illumination light precautions -

This product is equipped with high intensity illumination in order to obtain sufficient brightness for observing the inspection object. When the illumination of this product is turned ON, the intense light comes out from the distal end of the insertion tube of the scope unit. Comply strictly with the precautions described below when using this product.

---

**⚠CAUTION:****Turn OFF the illumination if not necessary.**

If the illumination light enters your eyes, your eyes may get injured. If you see the illumination light for a long time even though it is at the edge of your field of view, your eyes may get injured.

If there is any possibility that the illumination light enters human eyes, turn OFF the illumination if not necessary.

In particular, be careful the illumination turns ON automatically in the following cases.

- When you turn ON the power while the optical adapter is attached.
- When you attach the optical adapter while the power is turned ON.

**Do not stare at the illumination light.**

Otherwise, your eyes may get injured. If you stare at the illumination light for a long time even though seeing it diagonally or from the side, your eyes may get injured.

---

**⚠CAUTION:**

**Do not stare at the light reflected from the illumination light.**

The light reflected from the illumination light may be collected depending on the shape of the reflection surface. If such reflected light enters your eyes, your eyes may get injured.

**If there are people around you, call attention according to the precautions described in this chapter.**

People around you may get eye injury.

**Do not leave the distal end of the insertion tube keeping its illumination turned ON near flammable substances for a long time.**

Otherwise, fire may result.

**Information of IEC62471**

- RISK GROUP2
  - **⚠CAUTION** : Possibly hazardous optical radiation emitted from this product. Do not stare at operating lamp. May be harmful to the eyes.

Manufactured by

**EVIDENT CORPORATION**

6666 Inatomi, Tatsuno-machi, Kamiina-gun, Nagano 399-0495, Japan

Distributed by

**EVIDENT EUROPE GmbH**

Caffamacherreihe 8-10, 20355 Hamburg, Germany

**EVIDENT EUROPE GmbH UK Branch**

Part 2nd Floor Part A, Endeavour House, Coopers End Road, Stansted CM24 1AL, U.K.

**EVIDENT SCIENTIFIC, INC.**

48 Woerd Ave Waltham, MA 02453, U.S.A.

**EVIDENT AUSTRALIA PTY LTD**

97 Waterloo Road, Macquarie Park, NSW 2113, Australia

**Life science solutions**

Service Center



<https://www.olympus-lifescience.com/support/service/>

Official website



<https://www.olympus-lifescience.com>

**Industrial solutions**

Service Center



<https://www.olympus-ims.com/service-and-support/service-centers/>

Official website



<https://www.olympus-ims.com>