

# INSTRUCTIONS

# SZX16

## RESEARCH HIGH-CLASS STEREO MICROSCOPE

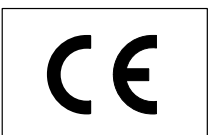

To ensure the safety, obtain optimum performance and to familiarize yourself full with the use of this microscope, we recommend that you study this manual thoroughly before operating the microscope. For details of products included in the configuration of this system, see "1 NOMENCLATURE" (P.4) and "9 OPERATION OF OTHER MODULES" (P.22).

Optical Microscope and Accessory



## CONTENTS

<b>IMPORTANT</b> .....	<b>1</b>
<b>1 NOMENCLATURE</b> .....	<b>4</b>
<b>2 CONTROLS</b> .....	<b>5</b>
<b>3 SUMMARY OF OBSERVATION PROCEDURE</b> .....	<b>6</b>
3-1 Preparation .....	6
3-2 Observation Procedure .....	6
<b>4 USING THE CONTROLS</b> .....	<b>7</b>
4-1 Base .....	7
<b>1</b> Using the Stage Plate .....	7
<b>2</b> Placing the Specimen .....	7
4-2 Microscope Body and Focusing Assembly .....	7
<b>1</b> Adjusting the Tension of the Coarse Focus Adjustment Knob .....	7
<b>2</b> Engaging and Disengaging the Zooming Knob Click Stop Function .....	8
<b>3</b> Adjusting the Aperture Iris Diaphragm .....	8
<b>4</b> Zoom Magnification Indication .....	9
<b>5</b> 2X Objective Correction Collar .....	9
4-3 Observation Tube .....	10
<b>1</b> Adjusting the Interpupillary Distance .....	10
<b>2</b> Adjusting the Diopter (Zoom Parfocal Adjustment) .....	10
<b>3</b> Using the Eye Shades .....	11
<b>4</b> Mounting the Eyepiece Micrometer Disk .....	11
<b>5</b> Selecting the Light Path .....	12
<b>6</b> Adjusting the Tilt .....	12
4-4 Camera Observation and Photomicrography .....	13
<b>1</b> Selecting the Camera Adapter Magnification .....	13
<b>2</b> Mounting the Camera Adapter .....	13
<b>3</b> Selecting the Camera Light Path .....	13

<b>5 TROUBLESHOOTING GUIDE .....</b>	<b>14</b>
<b>6 SPECIFICATIONS .....</b>	<b>15</b>
<b>7 OBSERVATION MAGNIFICATIONS AND OBSERVATION AREAS .....</b>	<b>17</b>
<b>8 ASSEMBLY .....</b>	<b>18</b>
8-1 Assembly Diagram.....	18
8-2 Detailed Assembly Procedure .....	19
<b>9 OPERATION OF OTHER MODULES.....</b>	<b>22</b>
9-1 Drop Prevention Collar SZX-R and Auxiliary Pillar SZH-P400/SZH-P600 .....	22
9-2 Revolving Nosepiece SZX2-2RE16.....	23
9-3 BX Stage Adapter Type 1 SZX-STAD1 .....	26
9-4 BX Stage Adapter Type 2 SZX-STAD2 .....	27
9-5 Stage Adapter Type 1 SZH-STAD1 .....	29
9-6 Gliding stage SZH-SG.....	30
9-7 Cup stage SZH-SC.....	31

# IMPORTANT

## ⚠ SAFETY PRECAUTIONS

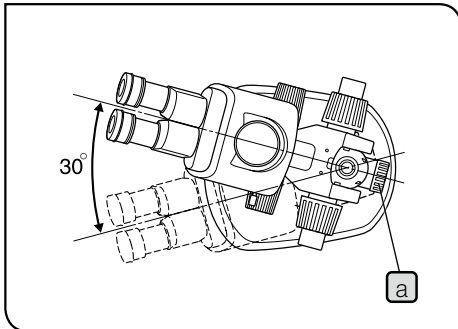

1. After the equipment has been used in an observation of a specimen that is accompanied with a potential of infection, clean the parts coming in contact with the specimen to prevent infection
  - Moving this microscope is accompanied with the risk of dropping the specimen and causing infections. Be sure to remove the specimen before moving this product.
  - In case the specimen is damaged by erroneous operation, promptly take the infection prevention measures.
  - The microscope may become unstable when certain intermediate attachments and/or photography unit are mounted on it. Take the measures so that the microscope does not turn over.
2. To prevent the microscope body from turning over, its left-right pivot angle must be limited to 30° as shown in figure. The tilt of the desktop surface should be no more than 5°.
3. Sufficient care is required during observation with a low-magnification objective, because the objective's long WD (Working Distance) can displace the microscope body to a higher position.  
The measures for prevention of turning over are also required when using an auxiliary pillar (SZH-P400/P600), because this also makes the microscope body to be displaced to a higher position.
4. To adjust the microscope body height, be sure to hold the microscope body with one hand while loosening the focusing assembly clamping knob **a**.  
(Use the drop prevention collar (SZX-R) to prevent a hazard from occurring.)  
Be careful not to pinch your finger during the adjustment.

## 1 Getting Ready

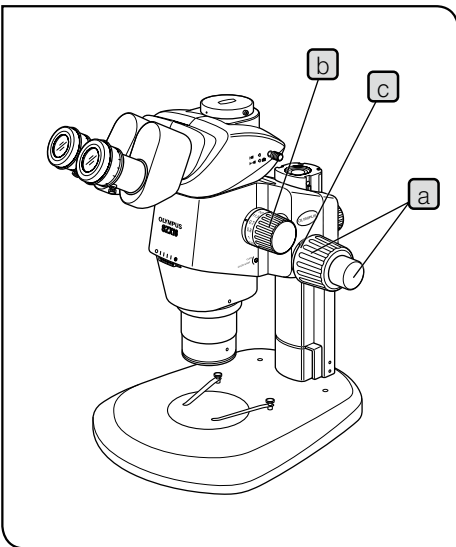
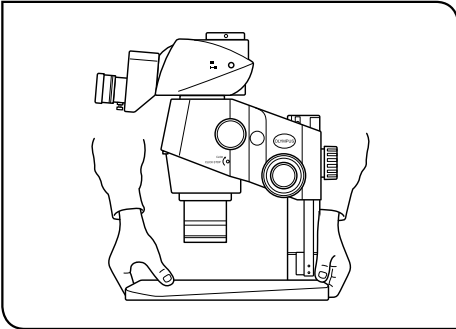

1. A microscope is a precision instrument. Handle it with care and avoid subjecting it to sudden or severe impact.
2. Do not use the microscope where it is subjected to direct sunlight, high temperature and humidity, or vibration. (For the operating environment, see "6 SPECIFICATIONS" (P.15).)
3. When moving the microscope, remove the specimen in advance. Then, hold the front part of the base with one hand and hold the rear part of the base with the other hand to avoid tilting the microscope.  
Also remove any module or attachment from the microscope to minimize the weight before moving.
4. Observe the following cautions when operating the coarse focus adjustment knob or the zooming knob.

Operation	Manipulated Controls	Caution
Focusing	Coarse/fine focus adjustment knobs <b>a</b>	1. If the knob hits the upper or lower limiting mechanism violently or it is rotated after it hits a limiting mechanism, the internal mechanism may be damaged.
		2. If the knobs on the left and right are rotated in opposite directions, the internal mechanism will be damaged. (The rotation tension of the coarse focus adjustment knob should be adjusted using the rotation tension adjustment ring <b>c</b> on the knob. See page 7.)
Zooming	Zooming knob <b>b</b>	1. If the knob hits the upper or lower limiting mechanism violently or it is rotated after it hits a limiting mechanism, the internal mechanism may be damaged.
		2. If the knobs on the left and right are rotated in opposite directions, the internal mechanism will be damaged.

5. Only one intermediate attachment can basically be used, but two attachments may also be used though the peripheral part of the image may be obscured.  
For the coaxial vertical illuminator (SZX2-ILLC16) and reflected fluorescent light illuminator (SZX2-RFA16), only either can be attached because they must always be attached at the lowest position.

## 2 Maintenance and Storage

1. To clean the lenses and other glass components, simply blow dirty away using a commercially available blower and wipe gently using a piece of cleaning paper (or clean gauze). If a lens is stained with fingerprints or oil smudges, wipe it gauze slightly moistened with commercially available absolute alcohol.
 

**CAUTION** Since the absolute alcohol is highly flammable, it must be handled carefully. Be sure to keep it away from open flames or potential sources of electrical sparks – for example, electrical equipment that is being switched on or off. Also remember to always use it only in a well-ventilated room.
2. The equipment uses plastic resins extensively in its external finish. Do not attempt to use organic solvents to clean them but simply wipe them using a lint-free, soft cloth. To clean an extremely dirty part, use a soft cloth lightly moistened with a diluted neutral detergent.
3. Never disassemble any part of the microscope as this could result in malfunctions or reduced performance.
4. When not using the microscope, keep it covered with the dust cover provided. If a module containing a source of heat is mounted on the microscope, wait until it has cooled down before covering.
5. This equipment should be disposed of by following the rules and regulations of your national or local government.

## 3 Caution

If the microscope is used in a manner not specified by this manual, the safety of the user may be imperiled. In addition, the microscope may also be damaged. Always use the microscope as outlined in this instruction manual.

The following symbols are used to set off text in this instruction manual.

**CAUTION** : Indicates that failure to follow the instructions in the warning could result in bodily harm to the user and/or damage to equipment (including objects in the vicinity of the equipment).

**NOTE** : Indicates that failure to follow the instructions could result in damage to equipment.

**TIP** : Indicates commentary (for ease of operation and maintenance).

## 4 Intended use

This product has been designed to be used to observe magnified images of specimens in various routine work and research applications. This includes the observation of living cells or of specimen taken from tissues to gain physiological or morphological information at hospitals or laboratories.

Typical field of applications are genetics, human blood and tissue examination, neurology, pharmacology and cellular biology. Further applications of this device include measurement and imaging for materials research, precision manufacturing, electronics design and medical device fabrication. Additional industrial applications are added by individual companies and researchers. Do not use this product for any purpose other than its intended use.



This product complies with the requirements of Regulation (EU) 2017/746 and The Medical Device (Amendment etc.) (EU Exit) Regulation 2020 concerning in vitro diagnostic medical devices. CE marking means the conformity to the former, and UKCA marking means the conformity to the latter.

This product is applied with the requirements of EMC standard IEC/EN61326-2-6 and IEC/EN61326-1 concerning electromagnetic compatibility.

- Immunity: Professional healthcare facility environment

Emissions exceeding the level required by aforementioned standards may occur if this product is electrically connected to other equipment.

This product complies with the emission and immunity requirements described in IEC61326 series.

This product is designed for use in a professional healthcare facility environment. It is likely to perform incorrectly if used in a home healthcare facility environment. If it is suspected that performance is affected by electromagnetic interference, correct operation may be restored by increasing the distance between this product and the source of the interference. The electromagnetic environment should be evaluated prior to operation of this product. Do not use this product in close proximity to the sources of strong electromagnetic radiation to prevent interference with the proper operation.

# 1 NOMENCLATURE

TIP

The following illustration shows a typical system composed of modules marked with "●" in the list of each module, and other modules may also be used in place of them. For the modules that are not shown in the module lists below, please contact us or the latest catalogues.

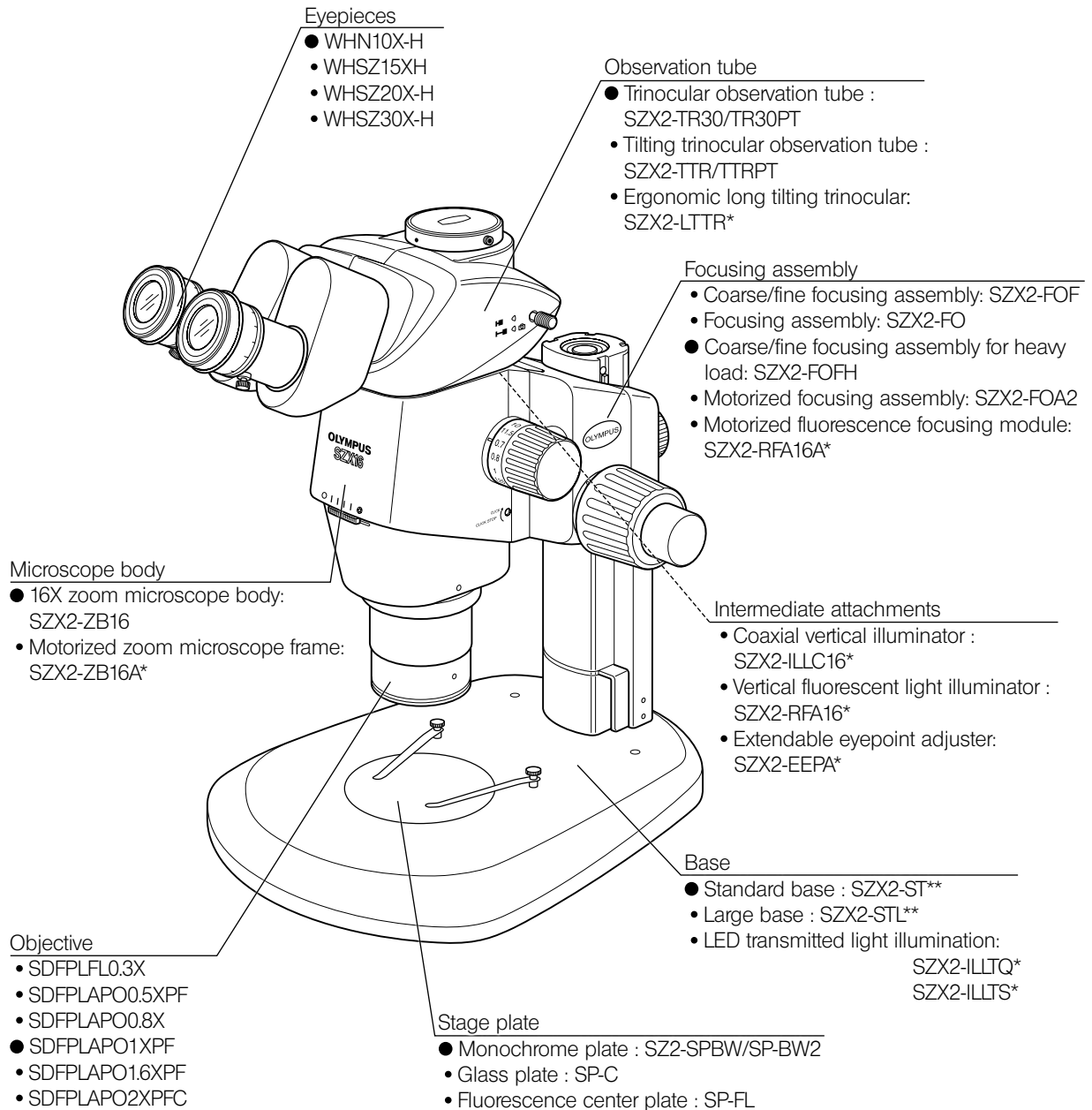

\* A separate instruction manual is available.

\*\* The standard base (SZX2-ST) requires use of the optional auxiliary pillar (SZH-P400 or SZH-P600) and optional drop prevention collar (SZX-R). The large base (SZX2-STL) comes with the auxiliary pillar (SZH-P400) mounted as standard. This enables the large base to be used as is. However, be sure to use the drop prevention collar (SZX-R) in combination.

We classify SZX2-ZB16 as an optical microscope and other units as optical microscope accessories.



# 2 CONTROLS

TIP

If the microscope is not yet assembled, see "8 ASSEMBLY" (P.18) before the following.

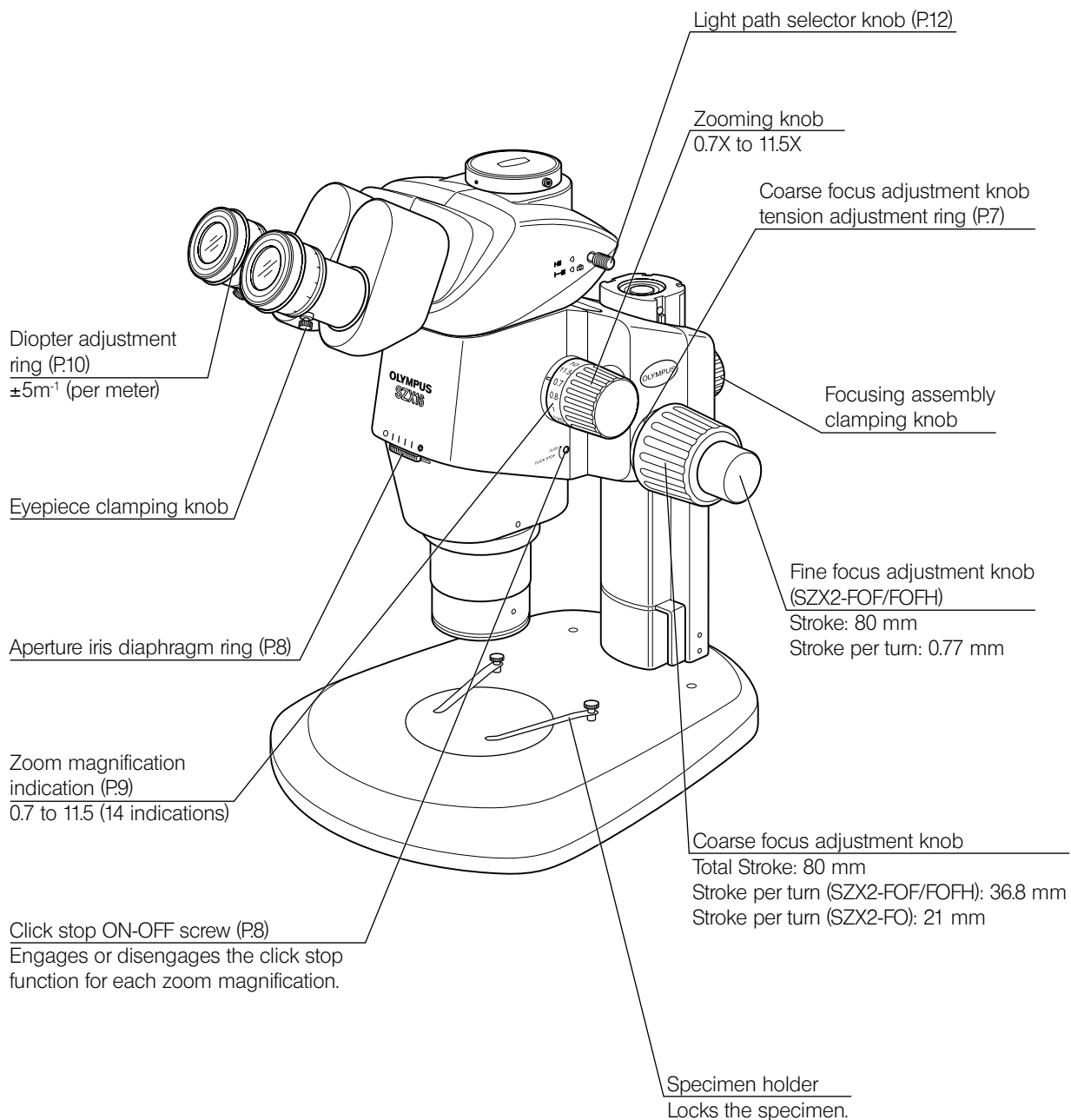

# 3 SUMMARY OF OBSERVATION PROCEDURE

## 3-1 Preparation

- |   | Ref. Page |
|---|-----------|
| 1. Check and tighten the connection of each component, especially the observation tube.....   | (Page 20) |
| 2. Check that the angle formed by the microscope body with respect to the base<br>is less than the turning-over prevention angle..... | (Page 19) |
| 3. Adjust the tension of the coarse focus adjustment knob.....  | (Page 7)  |
| 4. Confirm the correct settings.  |           |

## 3-2 Observation Procedure

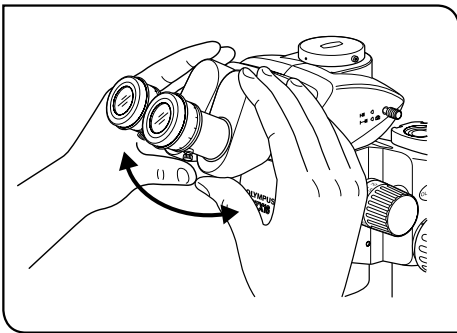

- 1 Place a specimen on the stage. (Page 7)
- 2 Adjust the interpupillary distance. (Page 10)

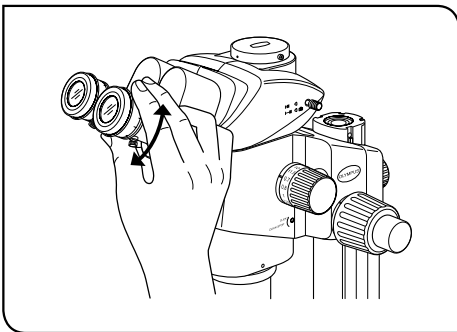

- 3 Make diopter adjustment of the eyepieces. (Page 10)  
( The adjustment procedure is variable depending on whether the eyepiece micrometer disk is used or not. )

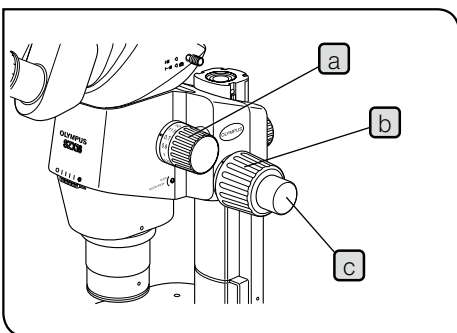

- 4 Set the zooming knob **a** to the lowest zoom magnification and bring the microscope into focus by rotating the coarse focus adjustment knob **b**.
- 5 Rotate the zooming knob **a** to the desired magnification and precisely focus the microscope on the specimen with the coarse focus adjustment knob **b** and fine focus adjustment knob **c** (the fine focus adjustment knob is not provided with the SZX2-FO).

**TIP** The contrast of the observed image and the focal depth of the specimen can be adjusted with the aperture iris diaphragm ring.

# 4 USING THE CONTROLS

## 4-1 Base

### 1 Using the Stage Plate

In reflected light observation, the stage plate can be placed either the white or black side facing up.

**NOTE** Win transmitted light observation, use the transparent glass stage plate (SP-C).

### 2 Placing the Specimen

- 1 Place the specimen on the approximate center of the stage plate. Hold the specimen with the specimen holder as required.
- 2 Illuminate the specimen with an illuminator selected according to the specimen under observation.

## 4-2 Microscope Body and Focusing Assembly

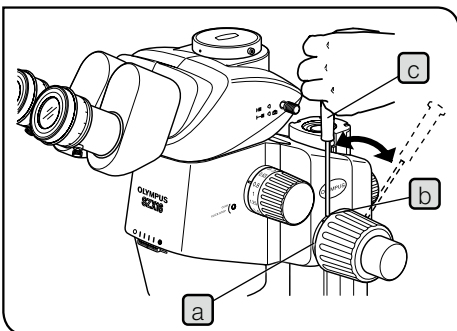

### 1 Adjusting the Tension of the Coarse Focus Adjustment Knob

**TIP** This operation is intended to facilitate the rotation of the knobs while preventing the spontaneous drop of the microscope body. It is recommended to set the knob tension to a slightly higher level than the point where spontaneous drop occurs. If the knobs are hard to move because of the weight of option modules and/or camera mounted on the microscope body, it is recommended to use the focusing assembly for heavy load (SZX2-FOFH).

**NOTE** The tension of the coarse focus adjustment knob can be adjusted with the tension adjustment ring **a**. Do not rotate the knobs on the left and right in opposite directions, for this will damage the internal mechanism.

- 1 Rotate the tension adjustment ring **a** by inserting the Allen screwdriver **c** into the hole **b** on the ring periphery. Rotating the ring clockwise increases the tension of the coarse focus adjustment knob, and rotating counterclockwise decreases it.

**NOTE** • If the microscope body falls down by its own weight or the focus obtained by fine focusing is lost immediately, the tension adjustment may be too light. In this case, rotate the ring clockwise to increase the tension.

• If the tension adjustment is too tight, delicate focusing will be impossible and the knob may be damaged. Particularly, to prevent damage, never rotate the fine focus adjustment knob quickly while its tension is extremely tight.

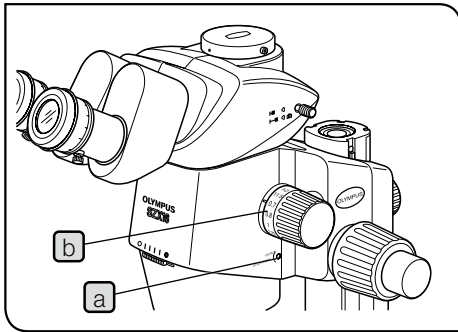

## 2 Engaging and Disengaging the Zooming Knob Click Stop Function

- TIP**
- When the click stop knob is set to ON, the click stop function is engaged for each magnification indicated with the zooming knob. When the knob is set to OFF, the zoom magnification can be varied continuously and finely near the click groove. The click stop knob has been set to OFF before the microscope is shipped from the factory.
  - A click stop is provided for each of the 12 intermediate indication positions of the zoom microscope body.

- 1** To engage the click stop function, rotate the click stop ON-OFF screw **a** fully clockwise (in the direction of the arrow) using the Allen screwdriver. The zooming knob then stops at every position corresponding to the magnification indicated on the zoom magnification indication **b**.
- 2** To disengage the click stop function, rotate the click stop ON-OFF screw **a** fully by three turns from the ON position, in the direction opposite to the arrow, using the Allen screwdriver.

**NOTE** Do not rotate the screw too much, or the cover may be damaged.

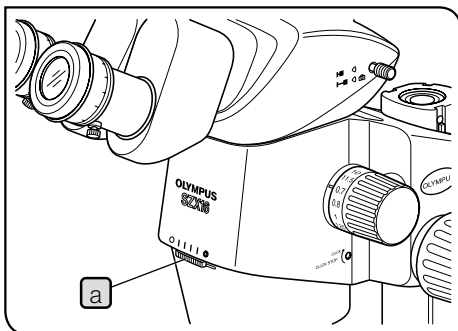

## 3 Adjusting the Aperture Iris Diaphragm

- TIP** Adjusting the aperture iris diaphragm increases the contrast of the observed image as well as the depth of focus. However, setting the aperture iris diaphragm too narrowly degrades resolution.

- 1** Adjust the aperture iris diaphragm ring **a** to the left or right. Rotating the ring toward the left (○) opens the aperture; rotating it toward the right (⊗) closes it. Adjust while monitoring the observed image to confirm the contrast and focal depth improvement effects.

**NOTE** Do not close the aperture too much, for this may cause degradation in resolution and/or lack of ambient light.

- 2** Use the scale gradations as references for memorizing the ring position.

**NOTE** When the microscope is combined with the coaxial vertical illuminator (SZX2-ILLC16), minimizing the aperture may obscure a part of the observed field of view. In this case, open the aperture to an intermediate position.

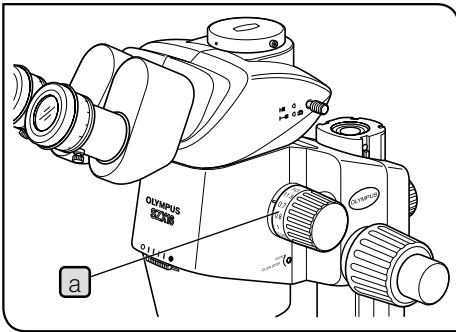

#### 4 Zoom Magnification Indication

The body zoom magnification **a** is indicated on the zooming knob on the right side.

The total magnification of observation can be calculated with the following formula:

Objective magnification	x	Body zoom magnification	x	Eyeiece magnification
-------------------------	---	-------------------------	---	-----------------------

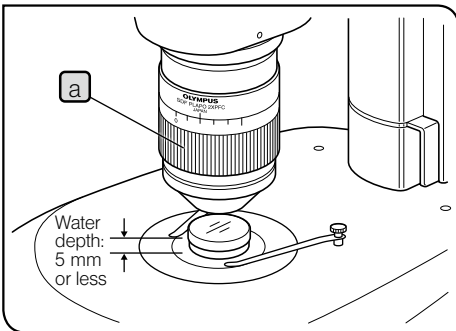

#### 5 2X Objective Correction Collar

TIP

• The SDFPLAPO2XPFC objective is provided with a correction collar **a** for use in compensating for the aberration caused due to the observation medium such as water and plastic container. When observing a specimen in a liquid or through a petri dish cover, turn the collar to obtain the optimum contrast.

- Correction is possible for aberration corresponding to water depth of about 5 mm.
- The correction effect may be less tangible when the zoom magnification is low or the aperture iris diaphragm is stopped down.
- When using the SZX2-2RE16 revolving nosepiece, hold the objective during rotation of the ring so that the revolving nosepiece is not deviated the click position.

## 4-3 Observation Tube

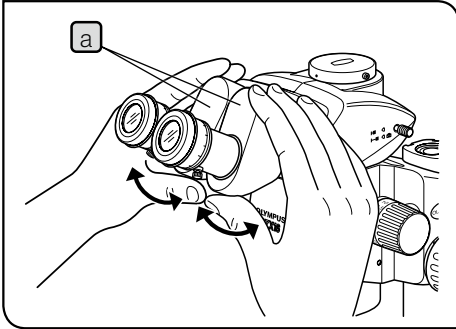

### 1 Adjusting the Interpupillary Distance

**NOTE** Be sure to hold the binocular assembly **a** with both hands to make this adjustment. To prevent damaging the mechanism, do not apply an excessive force beyond the stop position.

While looking through the eyepieces, hold the left and right of the binocular assembly **a** and adjust the eyepieces by opening or closing them for binocular vision until the left and right fields of view coincide completely.

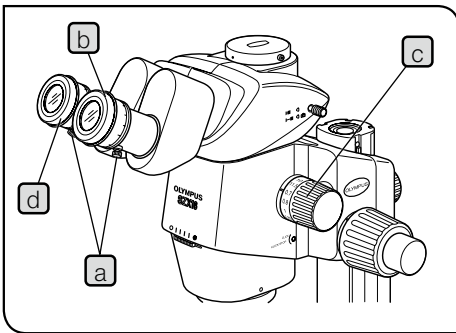

### 2 Adjusting the Diopter (Zoom Parfocal Adjustment)

**TIP** Ensure that the eyepiece clamping knob **a** is tightened before starting the adjustment. Adjusting the diopter specific to the two eyes of each observer allows the parfocality to be ensured across zoom magnifications.

When Not Using the Eyepiece Micrometer Disk

- 1 Look into the right eyepiece and rotate its diopter adjustment ring **b** so that the peripheral part of the visual field looks sharply.
- 2 Place an easy-to-observe specimen on the stage plate.
- 3 Rotate the zooming knob **c** to a low magnification and, looking only into the right eyepiece, focus the specimen using the coarse and fine focus adjustment knobs.
- 4 Rotate the zooming knob **c** to the highest magnification and, looking only into the right eyepiece, focus the specimen using the coarse and fine focus adjustment knobs.
- 5 Rotate the zooming knob **c** to the lowest magnification, look only into the left eyepiece, and focus the specimen by rotating the left diopter adjustment ring **d** instead of the coarse and fine focus adjustment knobs.

When Using the Eyepiece Micrometer Disk

- 1 Look into the right eyepiece that includes the eyepiece micrometer disk, and focus the micrometer disk by rotating the diopter adjustment ring **b**.
- 2 Place an easy-to-observe specimen on the stage plate.
- 3 Rotate the zooming knob **c** to the highest magnification and, looking only into the right eyepiece, focus the specimen using the coarse and fine focus adjustment knobs. Ensure that both the eyepiece micrometer disk and specimen are focused accurately.

- 4 Rotate the zooming knob **c** to the lowest magnification, look only into the left eyepiece, and focus the specimen by rotating the left diopter adjustment ring **d** instead of the coarse and fine focus adjustment knobs.

**TIP** Note (or memorize) the diopter readings of the left and right eyepiece scales so that they can be duplicated quickly in the next observation.

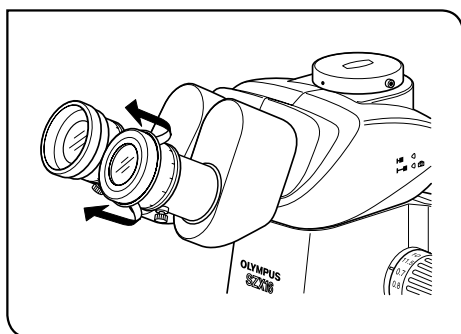

### 3 Using the Eye Shades

#### When Wearing Eyeglasses

Use with eye shades in their normal folded-down position. (This will prevent eyeglasses from being scratched by the eyepiece.)

#### When Not Wearing Eyeglasses

Extend the folded eyeshades in the direction of the arrow. This makes observation easier by preventing the inverse incidence of light from between the eyepiece and your eyes.

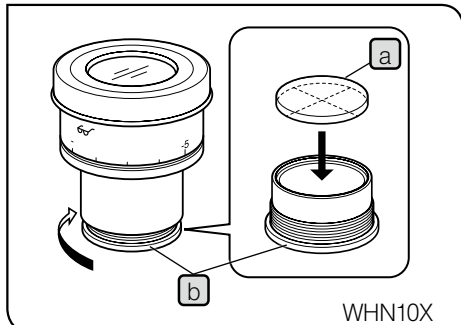

### 4 Mounting the Eyepiece Micrometer Disk

**TIP** • A variety of eyepiece micrometer disks can be inserted into the WHN10XH, WHSZ15X-H and WHSZ20X-H eyepieces. Use 24 mm dia. x 1.5 mm thick micrometer disks. Following figure, turn the built-in micrometer-mounting frame **b** to the arrow direction to remove it from the eyepiece and place a micrometer disk **a** into the mounting frame so that the surface with the model indication faces downward.

- The micrometer-mounting frame may be tight for certain micrometer disks. In this case, turn the frame by holding the circumference with a light, uniform force or by applying the frame against a rubber sheet. Do not grasp the frame with a strong force, as this may deform the frame and make it harder to remove it. Re-attach the micrometer mounting frame in the original position.
- Be careful not to touch the lens surface with your finger.



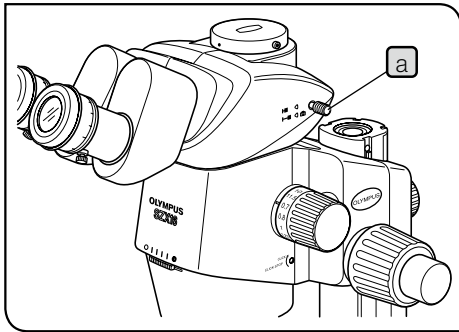

**Note** The WHSZ20X-H eyepiece is designed to apply a magnification to the focusing plane of the micrometer disk. As the magnification coefficient is 1.35, be sure to perform magnification compensation when using this eyepiece in measurement. When the micrometer disk is engaged in their light path, the light path length will extend and the diopter scale may deviate toward the + direction from the normal indication. However, this does not pose any problem in actual observation.

**TIP** When the eyepiece micrometer disk is not used, wrap it in a clean sheet of soft paper before storage.



## 5 Selecting the Light Path

**TIP** Pull out the light path selector knob **a** to set the light path for the right eyepiece to the camera light path. (The following table shows the intensity ratio of each light path in %)

Light Path Selector Knob		Pushed-in	Pulled-out
SZX2-TR30 SZX2-TTR (  ↔  )	Right	Binocular 100%	Binocular 50%
	Left		Camera 50%
SZX2-TR30PT SZX2-TTRPT (  ↔  )	Right	Binocular 100%	Camera 100%
	Left		Binocular 100%

**NOTE** Always push or pull the light path selector knob **a** all the way into a stop position. Do not attempt to force the knob past the stop position. Applying excessive force could destroy the mechanism.

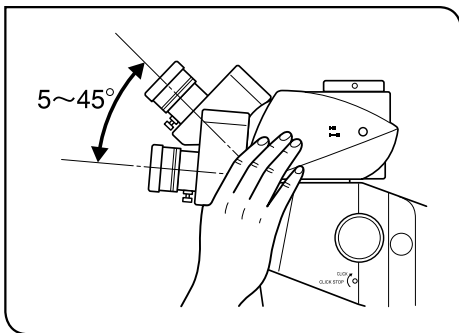

## 6 Adjusting the Tilt

**TIP** Adjust the height and tilt of the observation tube to the most comfortable viewing position. Holding the binocular assembly with both hands, raise or lower it to the desired position.

**NOTE** Do not attempt to force the binocular assembly past the upper or lower stop position. Applying excessive force could destroy the mechanism.



## 4-4 Camera Observation and Photomicrography

A digital camera unit can be mounted on the straight tube mount of the trinocular tube by means of the camera adapter and/or camera mount adapter\*.

\* The camera mount adapter is not necessary if a camera adapter equipped with a camera mount is used. For details, please also read the instruction manuals for the camera adapter and digital camera.

### 1 Selecting the Camera Adapter Magnification

Set the magnification of the camera adapter according to the size of the CCD in the digital camera.

(Example) The following figures show the camera observation/photomicrography areas when the WHN10X eyepieces with FN 22 are used.

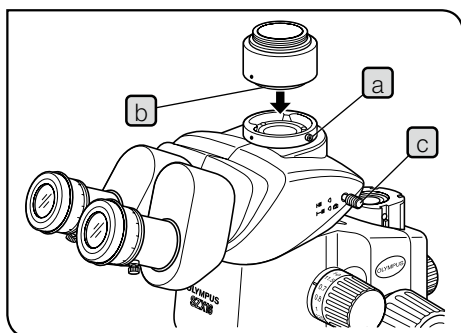
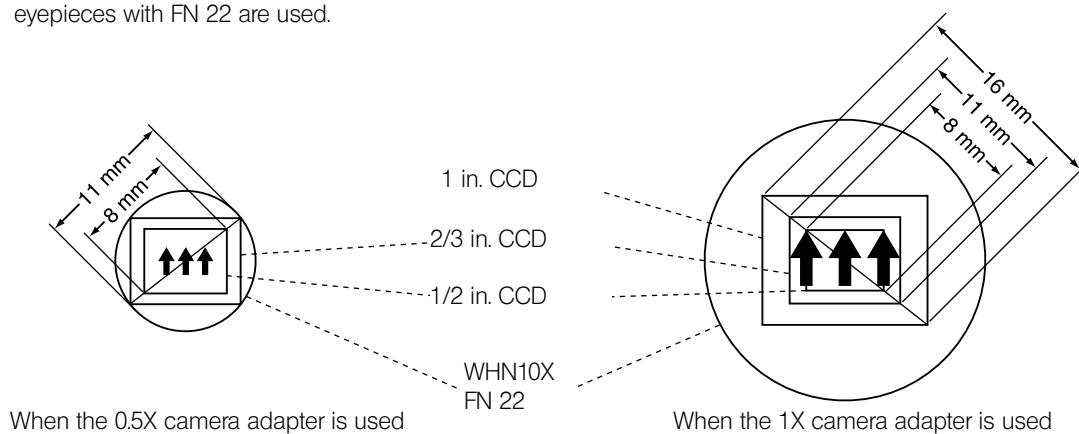

### 2 Mounting the Camera Adapter

- 1 Using the Allen screwdriver, fully loosen the straight tube clamping screw **a** of the straight tube mount on the top of the trinocular tube.
- 2 Fit the round dovetail **b** of the camera adapter into the straight tube mount of the trinocular tube, and tighten the clamping screw **a**.
- 3 Mount the camera on the camera adapter. A camera mount adapter may be required with certain camera adapters.

### 3 Selecting the Camera Light Path

Pull out the light path selector knob **c** to select the Binocular 50%/Camera 50% light path setting for the SZX2-TR30/TTR or the Camera 100% light path setting for the SZX2-TR30PT/TTRPT.

# 5 TROUBLESHOOTING GUIDE

Under certain conditions, performance of this unit may be adversely affected by factors other than defects. If a problem occurs, please review the following list and take remedial action as needed. If you cannot solve the problem after checking the entire list, contact us.

Problem	Cause	Remedy	Page
1. The left and right fields of view do not coincide.	The interpupillary distance is adjusted improperly.	Adjust it correctly.	10
	The diopter is adjusted incorrectly.	Adjust it correctly.	10
	The left and right eyepieces are different.	Use a pair of matched eyepieces.	21
2. The field of view is obscured partially or illuminated unevenly.	The aperture iris diaphragm is stopped down excessively.	Open the aperture iris diaphragm.	8
	The trinocular observation tube and/or intermediate attachments are installed improperly.	Mount them properly.	20
	The light path selector knob is in an intermediate position.	Set it correctly to the desired position.	12
3. The monitor image is cut off partially.	The light path selector knob is pulled out incompletely.	Pull it out all the way.	12
4. Dirt or dust is visible in the field of view.	Dirt/dust on the specimen.	Clean thoroughly.	3
	Dirt/dust on eyepiece.	Clean thoroughly.	3
5. Details of observed image are solid.	The aperture iris diaphragm is stopped down excessively.	Open the aperture to a proper diameter.	8
6. Visibility of observed image is poor. <ul style="list-style-type: none"> <li>• Image is not sharp.</li> <li>• Contrast is insufficient.</li> </ul>	The objective is tilted.	Screw it correctly until it stops.	20
	The objective is dirty.	Clean thoroughly.	3
	The top and/or bottom lenses of the microscope body are dirty.		
7. Zooming causes defocusing of the observed image	The eyepiece diopter is adjusted improperly.	Adjust it correctly.	10
	The focus adjustment is in accurate.	Adjust focus at a high magnification.	10
8. The coarse focus adjustment knob does not rotate smoothly	The rotation tension of the knob is set too high.	Decrease the rotation tension to an optimum level.	7
9. The microscope body drops spontaneously, causing the focusing to be deviated during observation.	The rotation tension of the coarse focus adjustment knob is set too low.	Increase the rotation tension to an optimum level.	7
	The microscope body dropped spontaneously because the weight exceeded 10 kg.	Use a focusing assembly withstanding heavy loads. (SZX2-FOF: 2.7 to 15 kg. SZX2-FOFH: 8 to 25 kg.)	15

# 6 SPECIFICATIONS

Item	Specifications			
(1) Zoom microscope body • SZX2-ZB16	Left/right zoom magnification system. Zoom drive system: Horizontal knob. Click stop ON-OFF switchable per zoom magnification.			
	Zoom ratio: 16.4 (0.7X to 11.5X) Magnification indications: 14 indications. 0.7, 0.8, 1, 1.25, 1.6, 2, 2.5, 3.2, 4, 5, 6.3, 8, 10, 11.5.			
	Objective mount: Threaded mount			
	Built-in aperture iris diaphragm.			
(2) Focusing assembly • SZX2-FOFH • SZX2-FOF • SZX2-FO	SZX2-FOFH	SZX2-FOF	SZX2-FO	
	Focusing system: Rack & pinion roller guide (with coarse focus adjustment knob tension adjustment ring).			
	Built-in gas spring counter balance. Coaxial coarse/fine focus adjustment knobs.	Built-in counter balance. Coaxial coarse/fine focus adjustment knobs.	— Coarse focus adjustment knob only.	
	Coarse focus adjustment knob stroke: 80 mm			
	Coarse knob stroke per turn: 36.8 mm		Coarse knob stroke per turn : 21 mm	
	Fine focus adjustment knob stroke: 80 mm Fine knob stroke per turn: 0.77 mm		—	
	Load: 8 to 25 kg	Load: 2.7 to 15 kg	Max. load: 10 kg	
(3) Observation tube • SZX2-TR30 • SZX2-TR30PT • SZX2-TTR • SZX2-TTRPT	SZX2-TR30	SZX2-TR30PT	SZX2-TTR	SZX2-TTRPT
	Trinocular observation tube.		Tilting binocular observation tube.	
	Tube inclination: 30°		Tube inclination: 5° to 45°	
	Light path selection: 2 steps. (Binocular 100%, Binocular 50% / Camera 50%)	Light path selection: 2 steps. (Binocular 100%, Camera 100%)	Light path selection: 2 steps. (Binocular 100%, Binocular 50% / Camera 50%)	Light path selection: 2 steps. (Binocular 100%, Camera 100%)
	Interpupillary distance adjustment: 52 to 76 mm. Eyepiece clamping knobs provided. Eyepieces: WHN10X-H, WHSZ15X-H/20X-H/30X-H			
(4) Standard base • SZX2-ST	Pillar support sleeve height: 270 mm. Base dimensions: 284(W) x 335(D) x 31(H) mm. Specimen holder attachable. With stage adapter mounting holes.			
(5) Large base • SZX2-STL	Pillar height: 400 mm. Base dimensions: 400(W) x 350(D) x 28(H) mm. Specimen holder attachable. With stage adapter mounting holes. Drop prevention collar: Optional SZX-R.			

Item	Specifications	
(6) Objectives WD : Working distance PF : Parfocal lens	SDFPLFL0.3X SDFPLAPO0.5XPF SDFPLAPO0.8X SDFPLAPO1XPF SDFPLAPO1.6XPF SDFPLAPO2XPFC	WD 141 mm* WD 70.5 mm WD 81 mm WD 60 mm WD 30 mm WD 20 mm
(7) Eyepieces  (Note) The micrometer area outside the FN is invisible.	WHN10X-H ** FN 22, diopter adjustment ring provided. WHSZ15X-H ** FN 16 diopter adjustment ring provided. WHSZ20X-H ** FN 12.5 diopter adjustment ring provided. WHSZ30X-H FN 7 diopter adjustment ring provided.	
(8) Operating environment	<ul style="list-style-type: none"> <li>• Indoor use.</li> <li>• Altitude: Max. 2,000 m.</li> <li>• Ambient temperature: 5°C to 40°C. (41°F to 104°F)</li> <li>• Maximum relative humidity 80% for temperatures up to 31°C (88°F), decreasing linearly through 70% (at 34°C), 60% (at 37°C) to 50% (at 40°C).</li> </ul>	

\* Auxiliary pillar is required when the SZX2-ST is used

\*\* Ø24 mm dia., 1.5 mm thick eyepiece micrometer disk can be inserted.

## 7

## OBSERVATION MAGNIFICATIONS AND OBSERVATION AREAS

- Observation magnification = Objective magnification x Zoom magnification x Eyepiece magnification
- Observation area = Eyepiece FN / (Objective magnification x Zoom magnification) (mm)

Objective	Eyepieces							
	WHN10X-H FN 22		WHSZ15X-H FN 16		WHSZ20X-H FN 12.5		WHSZ30X-H FN 7	
	Obs. Mag.	Obs. Area	Obs. Mag.	Obs. Area	Obs. Mag.	Obs. Area	Obs. Mag.	Obs. Area
SDFPLFL0.3X	2.1X – 34.5X	104.8 – 6.4	3.15X – 51.75X	76.2 – 4.6	4.2X – 69X	59.5 – 3.6	6.3X – 103.5X	33.3 – 2.0
SDFPLAPO0.5XPF	3.5X – 57.5X	62.9 – 3.8	5.25X – 86.25X	45.7 – 2.8	7X – 115X	35.7 – 2.2	10.5X – 172.5X	20.0 – 1.2
SDFPLAPO0.8X	5.6X – 92X	39.3 – 2.4	8.4X – 138X	28.6 – 1.7	11.2X – 184X	22.3 – 1.4	16.8X – 276X	12.5 – 0.8
SDFPLAPO1XPF	7X – 115X	31.4 – 1.9	10.5X – 172.5X	22.9 – 1.4	14X – 230X	17.9 – 1.1	21X – 345X	10.0 – 0.6
SDFPLAPO1.6XPF	11.2X – 184X	19.6* – 1.2	16.8X – 276X	14.3 – 0.9	22.4X – 368X	11.2 – 0.7	33.6X – 552X	6.3 – 0.4
SDFPLAPO2XPFC	14X – 230X	15.7* – 1.0	21X – 345X	11.4* – 0.7	28X – 460X	8.9 – 0.5	42X – 690X	5.0 – 0.3

\* Part of the peripheral areas in the field cut off at low magnifications.

# 8 ASSEMBLY

## 8-1 Assembly Diagram

The diagram below shows how to assemble the various modules. The numbers indicate the order of assembly.

**NOTE** When assembling the microscope, make sure that all parts are free of dust and dirt, and avoid scratching any part.

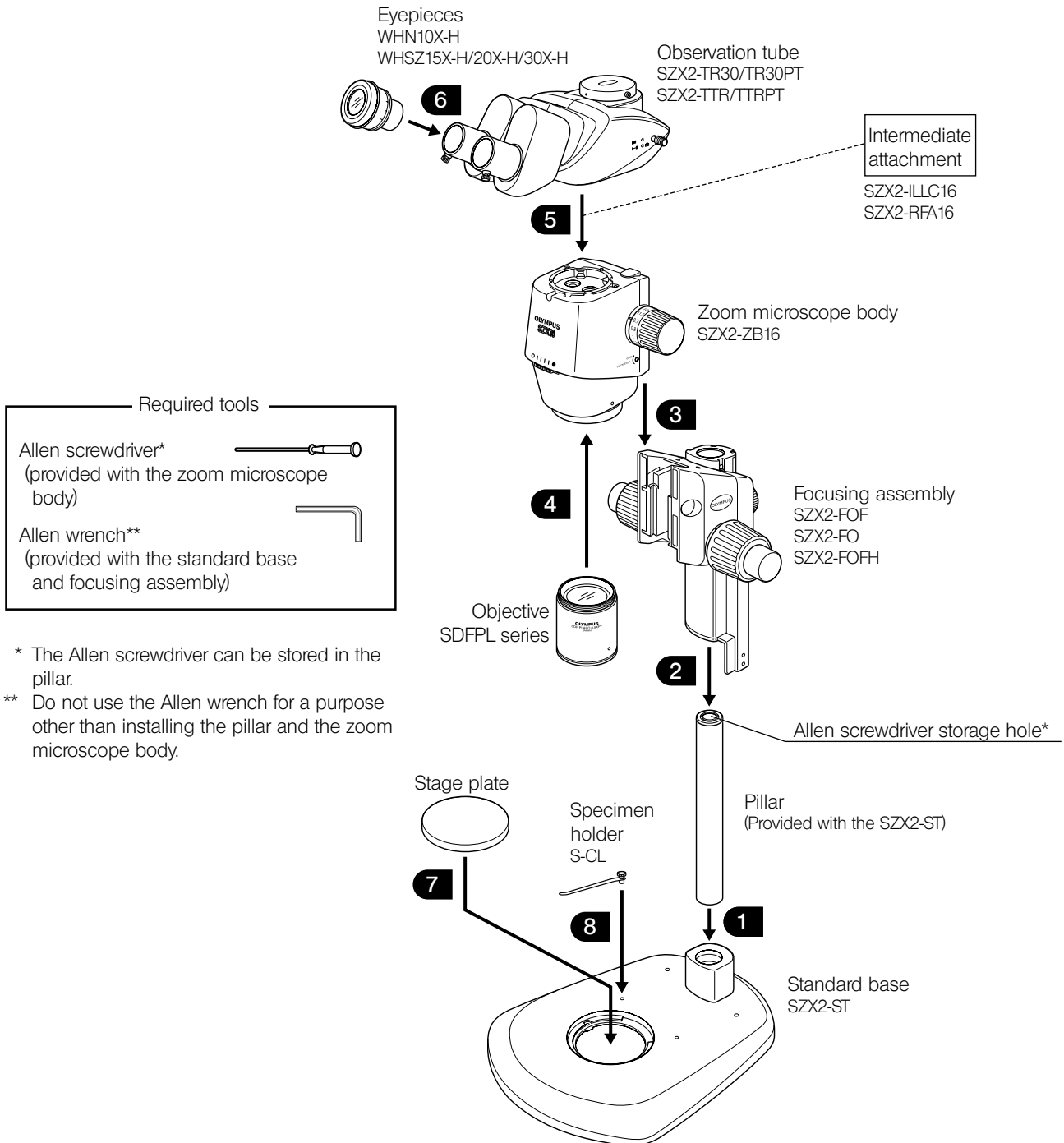

\* The Allen screwdriver can be stored in the pillar.

\*\* Do not use the Allen wrench for a purpose other than installing the pillar and the zoom microscope body.

## 8-2 Detailed Assembly Procedure

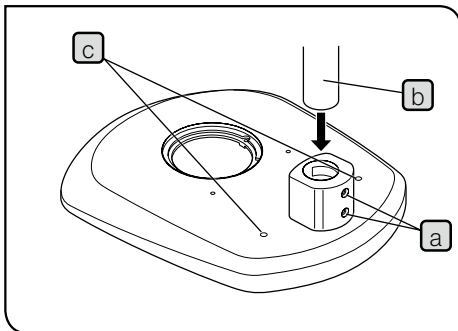

### 1 Installing the Pillar

- 1 Using the Allen wrench provided with the base, loosen the two clamping screws **a** on the pillar support sleeve completely.
- 2 Hold the pillar **b** so that the Allen screwdriver storage hole comes cap at the top, and insert the pillar into the pillar support sleeve until it reaches the bottom.
- 3 Using the provided Allen wrench, tighten the two clamping screws **a** securely.

#### Reserve Screw Holes

Two screw holes **c** (6 mm) are provided for use in mounting a manipulator, etc.

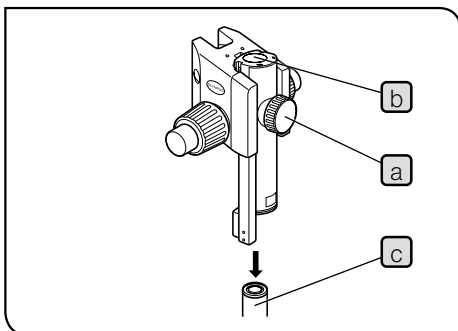

### 2 Mounting the Focusing Assembly

- 1 First loosen the focusing assembly clamping knob **a** completely and, while holding the focusing assembly with both hands, insert the pillar **c** into the mounting hole **b** from below.

**NOTE** Insert slowly. Do not apply excessive force.

- 2 Lower the focusing assembly until it stops, then tighten the focusing assembly clamping knob **a**.

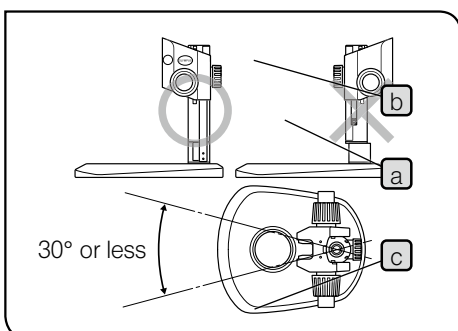

#### CAUTION

To prevent the microscope from turning over, the focusing assembly must be installed on the same side as the stage plate in the stand, as shown in the illustration marked "O" in figure, and its pivot angle must be limited to 30°. If the focusing assembly is placed on the wrong side, the microscope will turn over.

#### NOTE

If the clamping knob **a** is tightened while the pillar **c** is not completely inserted into the mounting hole **b**, the plate spring supporting the pillar will deform and the pillar will not be able to penetrate into the hole.

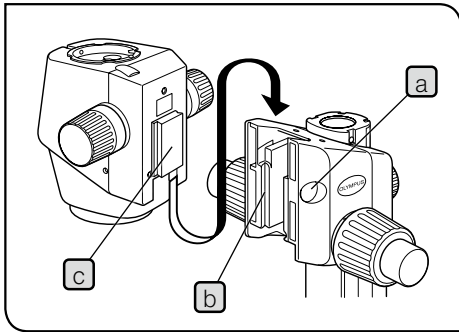

### 3 Mounting the Microscope Body

- 1 Remove the cap **a** on the focusing assembly by inserting a thin object into the notch.
- 2 Using the provided Allen wrench, loosen the dovetail mount clamping screw inside the cap on the focusing assembly by rotating it by 2 or 3 turns (counterclockwise).
- 3 Gently insert the dovetail mount **c** on the rear of the microscope body into the dovetail mounting port **b** on the focusing assembly.

**NOTE** Do not insert the mount at an angle or with excessive force, for this may cause malfunctions.

- 4 When the microscope body has been inserted until it stops, tighten the clamping screw using the Allen wrench.
- 5 Place the cap **a** in the original position.

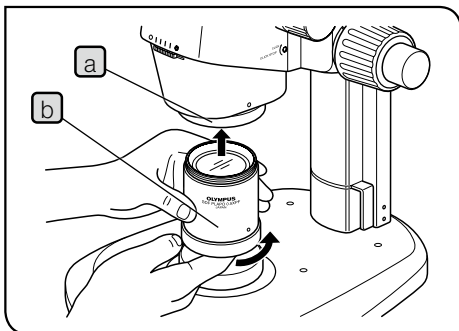

### 4 Mounting the Objective

**NOTE** Since the objective is heavy, take the following measures to prepare for an accident in case it is dropped.

- Attach the cap to the objective tip.
- Place the cap of the objective mount thread or a notebook, etc. on the stand to absorb the shock even when the objective drops.

While holding the tip of the objective **b**, mount it on the objective mount thread **a** by rotating the objective in the direction of the arrow.

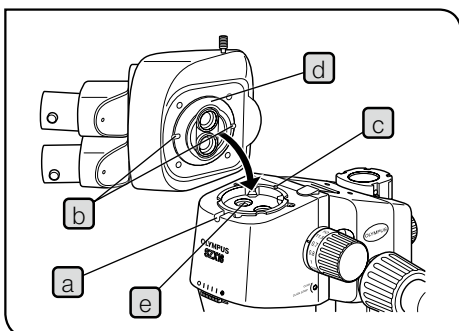

### 5 Mounting the Observation Tube

- 1 Using the Allen screwdriver, loosen the observation tube clamping screw **a** completely.
- 2 Aligning the positioning pin **c** of the microscope body to the positioning groove **b** on the observation tube, insert the dovetail mount **d** at the bottom of the observation tube into the mounting port **e** on the microscope body.

- 3 Using the Allen screwdriver, tighten the observation tube clamping screw **a**.

**NOTE** The observation tube can be mounted 180° from the above position, but this positioning makes observation difficult and is not recommended. When the auxiliary pillar is used, this positioning is impossible because the eyepiece gets in the way.



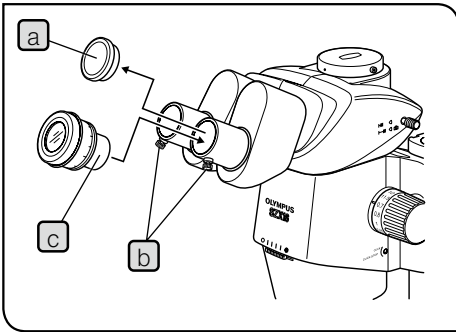

## 6 Mounting the Eyepiece

TIP

When using the micrometer eyepiece disk, insert it in the right eyepiece. (It may be inserted in the left eyepiece but the description in this manual assumes that it is inserted in the right eyepiece.)

- 1 Remove the eyepiece dust caps **a** and loosen the eyepiece clamping screws **b** completely.
- 2 Gently insert the eyepieces of the same magnification **c** into the left and right eyepiece sleeves all the way until they stop.
- 3 Tighten both eyepiece clamping screws **b**.

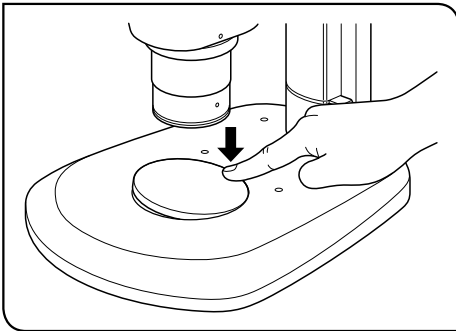

## 7 Mounting (Removing) the Stage Plate

Place the stage plate into the mounting hole on the base.

To remove, press the stage plate at the edge nearest to the pillar with your fingertip. The opposite end will rise from the base so the stage plate can be picked up easily.

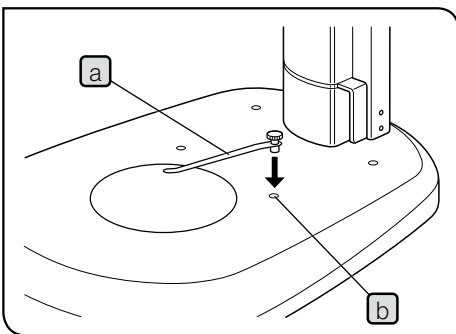

## 8 Mounting the Specimen Holder

TIP

Use the specimen holder when you want to hold the specimen so that it will not move.

Insert the specimen holder **a** into the two holes **b** on the top surface of the base.

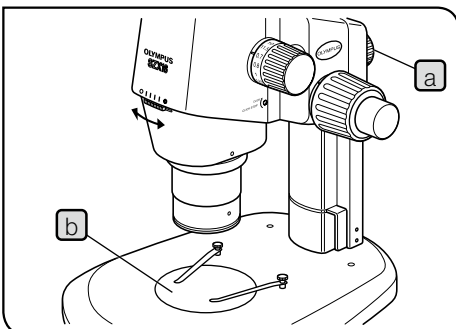

## 9 Positioning the Microscope Body on the Stand

Loosen the focusing assembly clamping knob **a**. Slightly pivoting the microscope body to the left and right, align the center of the objective with the center of the stage plate **b**, then clamp the microscope body with the focusing assembly clamping knob.

# 9 OPERATION OF OTHER MODULES

## 9-1 Drop Prevention Collar SZX-R and Auxiliary Pillar SZH-P400/SZH-P600

- TIP**
- The auxiliary pillar is to be used when observing a large specimen or when it is required to move the microscope body upward for using a low-magnification objective with long WD.
  - The drop prevention collar prevents the zoom microscope body from dropping when installed at a high position using the auxiliary pillar and the clamping knob on the focusing assembly is loosened carelessly. This helps to avoid accidental damage to the specimen or objective.

**NOTE** The static load resistance of the SZX-R is 7 kg at maximum.

### 1 Assembly

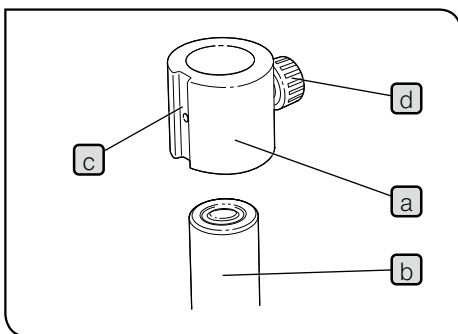

#### 1 Mounting the auxiliary pillar

- Remove the pillar from the standard base and replace the pillar with the SZH-P400 or SZH-P600 auxiliary pillar (see page 19 for the mounting procedure).

#### 2 Mounting the drop prevention collar

- Fit the drop prevention collar **a** onto the auxiliary pillar **b**.

**TIP** Position the oblique illumination unit mounting groove **c** on the front side of the drop prevention collar **a** and tighten the clamping knob **d**.

**NOTE** When the specimen height is low or an objective with a short working distance is used, the drop prevention collar **a** does not have to be mounted if you move the microscope body downward. However, this reduces safety that is assured by using the SZX-R drop prevention collar **a**, so be always sure to hold the focusing assembly firmly when loosening the focusing assembly clamping knob.

### 2 Operation

**CAUTION** When moving the microscope body around the pillar, never loosen both the focusing assembly clamping knob and drop prevention collar simultaneously.

To Move the Microscope Body Upward

- 1 Loosen the clamping knob of the focusing assembly to be moved upward.
- 2 At the desired height, tighten the focusing assembly clamping knob securely.
- 3 Loosen the drop prevention collar clamping knob, press the drop prevention collar tightly against the lower end of the focusing assembly, and tighten the clamping knob securely.

To Move the Microscope Body Downward

First loosen the drop prevention collar, move the microscope body downward, and then move the focusing assembly.

**NOTE** For the drop prevention collar to exhibit its full effect, clamp the focusing assembly and drop prevention collar in close contact between each other, without leaving any space.

## 9-2 Revolving Nosepiece SZX2-2RE16

**TIP**

The revolving nosepiece allows two objectives to be mounted (deviation in focusing due to switching between the objectives can be minimized provided that both of them are of the PF series). This makes objective switching easy by simply rotating the revolving nosepiece and expands the range of observation magnifications.

### 1 External View

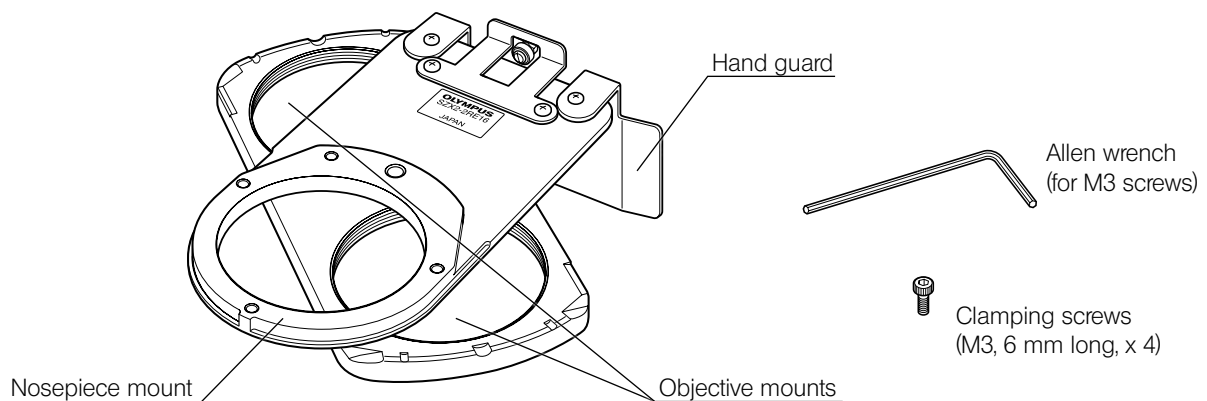

### 2 Assembly

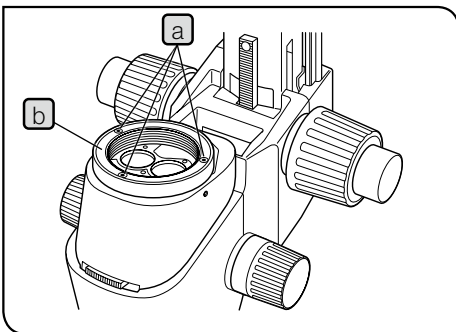

- 1** Remove the observation tube from the zoom microscope body.
- 2** Remove the zoom microscope body and focusing assembly from the pillar, and place them upside down on a flat desk surface.

**NOTE** Place a soft sheet made of rubber or similar material on the desk surface.

- 3** Remove the objective from the zoom microscope body and then remove the objective mount **(b)** by loosening the three clamping screws **(a)** using the provided Allen wrench (for M3 screws).

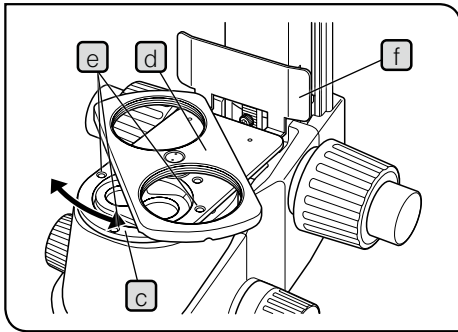

- 4 Place the revolving nosepiece mount (c) (with its objective mounts (d) facing upward) where the objective mount has been by aligning the screw holes. Using the Allen wrench (for M3 screws), clamp the revolver mount with the provided three clamping screws (M3, 6 mm long) (e).

**NOTE** • Two screw holes are provided at each position with an interval of 5 mm. When not using the SZX2-RFA16 reflected fluorescent light illuminator, use the screw holes closer to the front.

- As the screw holes may be hidden behind the objective mounts (d), clamp the nosepiece mount while rotating it.

- 5 Install the focusing assembly on the pillar, and install the observation tube in the original position.
- 6 Attach two objectives onto their respective objective mounts (d) by screwing.

### 3 Operation

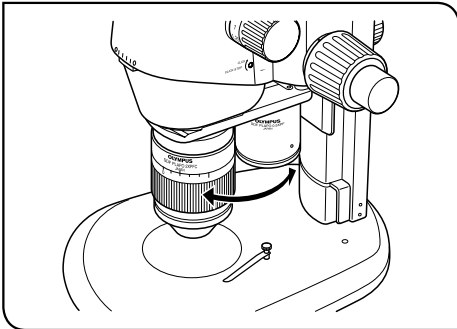

Hold the objective and gently rotate it until a click position on the front, where the objective to be used is engaged in the light path.

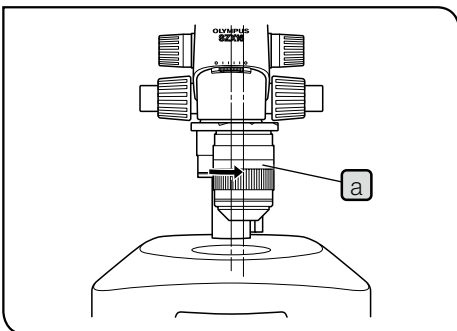

#### Operation for Optical Axis Aligned Photomicrography

**TIP** Align the center of objective and that of the illumination light path with the photo light path (the right line) to enable photomicrography with high contrast.

- 1 Rotate the desired objective (a) clockwise (17°) till the click position for the photo light path.

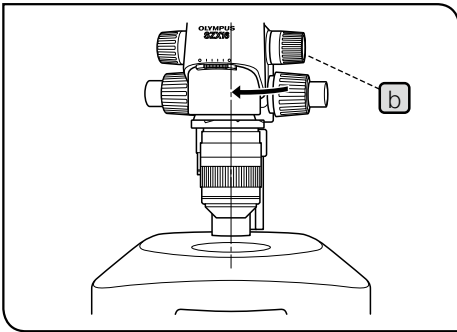

- 2 Return the microscope body to the illumination light path by loosening the focusing module clamping knob **b**, rotating the microscope body gently in the direction of the arrow, aligning visually the objective with the illumination light path and tightening the clamping knob **b** again. Now the setting of the photo light path is complete.

#### 4 Caution

- When transporting the microscope, do not hold it by the revolving nosepiece.
- The parfocal property when the objective is switched is not completely guaranteed.
- The SZX2-FO focusing assembly cannot be combined with this microscope.

## 9-3 BX Stage Adapter Type 1 SZX-STAD1

**TIP** This adapter is for installation of a U-SRG or U-SRP rotary stage on the SZX2 standard base or a SZX2 series illumination base. When the U-SRP rotary stage is used together with the U-FMP mechanical stage, X-Y directional movement becomes possible, which is convenient for framing during photomicrography. To cover the height of the stage adapter (about 44 mm), we recommend combination with the SZH-P400 auxiliary pillar (together with the SZX-R drop prevention collar).

### 1 Mountable Bases, Restrictions

Base	Applicable Objectives	Restrictions
Standard base SZX2-ST	0.5X to 2X	None
<ul style="list-style-type: none"> <li>Quad position LED transmitted light illumination base SZX2-ILLTQ</li> <li>Single position LED transmitted light illumination base SZX2-ILLTS</li> </ul>	STAD mount for ILLT SZX2-STADM is necessary for using the stage adapter. (Refer to the instruction manual for the SZX2-ILLTQ/ILLTS LED transmitted light illumination base.)	

### 2 Assembly

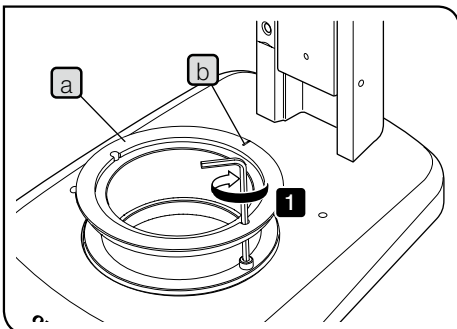

**TIP** Use the tools shown in the table below.

Tool	Description
Allen wrench (for M4 screw)	Provided with SZX-STAD1
Hexagon socket screw (M4)	Provided with SZX-STAD1

**1** Place the notch (b) of SZX-STAD1 (a) on the back side of the base, and secure the screws (2 pcs.) using the Allen wrench to attach SZX-STAD1 (a) to a base.

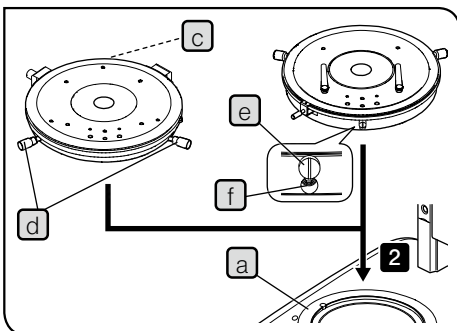

**2** Attach U-SRP or U-SRG2 to SZX-STAD1 (a).

#### Attaching U-SRP

Place the positioning pin (cylinder type) (c) on the back side of the base, and rotate the centering knob (d) in clockwise direction to secure it.

#### Attaching U-SRG2

Place the protrusion (e) on the front side of the base, and rotate the clamping screw (f) in clockwise direction to secure U-SRG2 using the allen screwdriver provided with the microscope frame.

## 9-4 BX Stage Adapter Type 2 SZX-STAD2

**TIP** This adapter is for installing the U-SIC4R2/SIC4L2 large stage\* on the SZX2-STL large stand\*\*. When this stage adapter is used, the SZH-P400 auxiliary pillar should be used to cover the height of the stage adapter (about 125 mm). In addition, when a low-magnification objective with a long working distance (SDFPLFL0.3X) is used, the SZH-P600 auxiliary pillar should be used (always together with the drop prevention collar).

\* The U-SVL or S-SVR BS stage for the BX series microscopes can also be mounted but the operability deteriorates. The U-SVLB and U-SVRB cannot be used due to their long stage knobs.

\*\* STAD mount for ILLT SZX2-STADM is necessary for using the SZX2-ILLTQ/ILLTS LED transmitted light illumination base. In addition, the LED transmitted illumination built in SZX2-ILLTQ/ILLTS cannot be used for observation. For details, refer to the instruction manual for the SZX2-ILLTQ/ILLTS LED.

### 1 Assembly

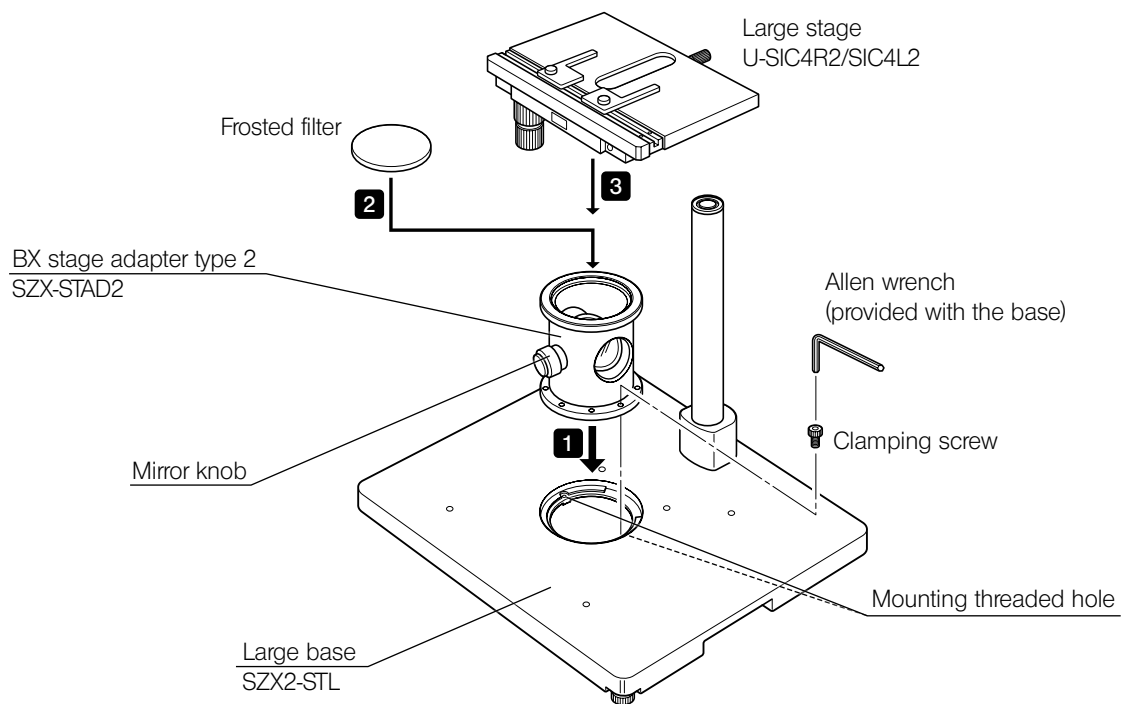

**NOTE** For simplified transmitted light observation, place the mirror knob on the front and use a frosted filter.

## 2 Simplified Transmitted Light Observation

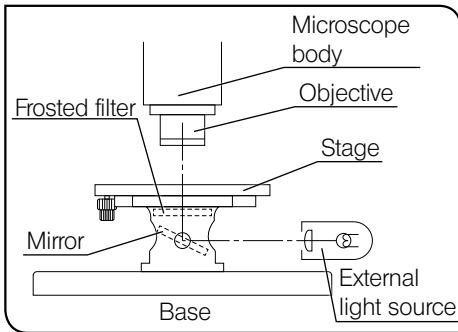

- 1** Illuminate the specimen with an external light source (LSD illuminator, light guide illuminator, etc.). Light the external light source as shown in the figure on the left and irradiate the mirror assembly.
- 2** Eliminate irregularities in illumination.
  - 1) Align the microscope body center with the center of the SZX-STAD2 adapter.
  - 2) Set the zooming knob on the microscope body to the minimum magnification and focus the stage top surface.
  - 3) While observing through the eyepiece, rotate the mirror knob to adjust the mirror angle so that the entire field of view is illuminated uniformly.

TIP

When observing using an oblique illuminator, remove the frosted filter and, while observing through the eyepiece, tilt the mirror gradually until optimum contrast can be obtained.

## 3 Caution

- Do not project the image of the external light source filament on the frosted surface of the frosted filter. Otherwise, the frosted filter may deteriorate.
- Use neutral detergent to clean the frosted filter.
- In transmitted light observation at a total magnification of no more than 10X, the field of view may be obscured in the peripheral sections depending on the stage in use.



## 9-5 Stage Adapter Type 1 SZH-STAD1

This adapter has the same function as the SZX-STAD1 BX stage adapter type 1, but the usable stages with this adapter are the BH2-SH horizontal knob stage.

### 1 Assembly

**TIP** STAD mount for ILLT SZX2-STADM is necessary for using the SZX2-ILLTQ/ILLTS LED transmitted light illumination base. For details, refer to the instruction manual for the SZX2-ILLTQ/ILLTS LED.

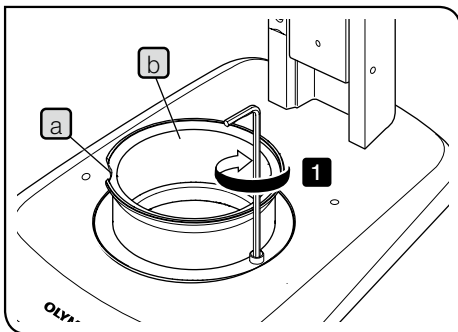

**TIP** Use the tools shown in the table below.

Tool	Description
Allen wrench (for M4 screw)	Provided with SZH-STAD1
Hexagon socket screw (M4)	Provided with SZH-STAD1

**1** Placing the notch **a** on the front side of the base, secure the screws (2 pcs.) using the Allen wrench to attach SZX-STAD1 **b** to a base.

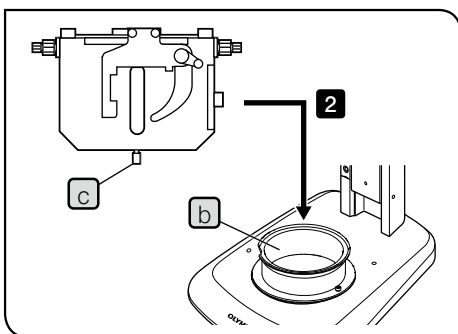

**2** Place the stage clamping knob **c** of BH2-SH (horizontal knob stage) on the front of the base, rotate the clamping knob **c** in clockwise direction to secure it, and attach BH2-SH.

## 9-6 Gliding stage SZH-SG

### 1 External view and nomenclature

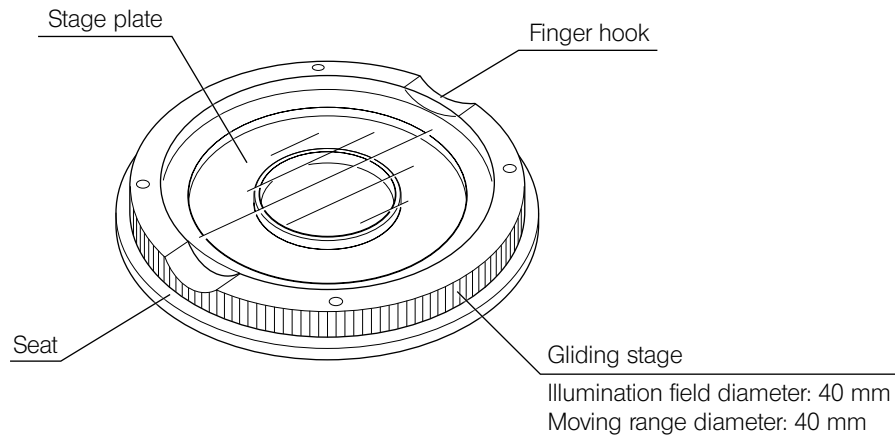

### 2 Installation

- NOTE**
- Be sure to clean the sliding surface if dirt or metallic powder is attached on them.
  - Do not place the gliding stage on the friction surface directly on the desktop.

**TIP** STAD mount for ILLT SZX2-STADM is necessary for using the SZX2-ILLTQ/ILLTS LED transmitted light illumination base. For details, refer to the instruction manual for the SZX2-ILLTQ/ILLTS LED.

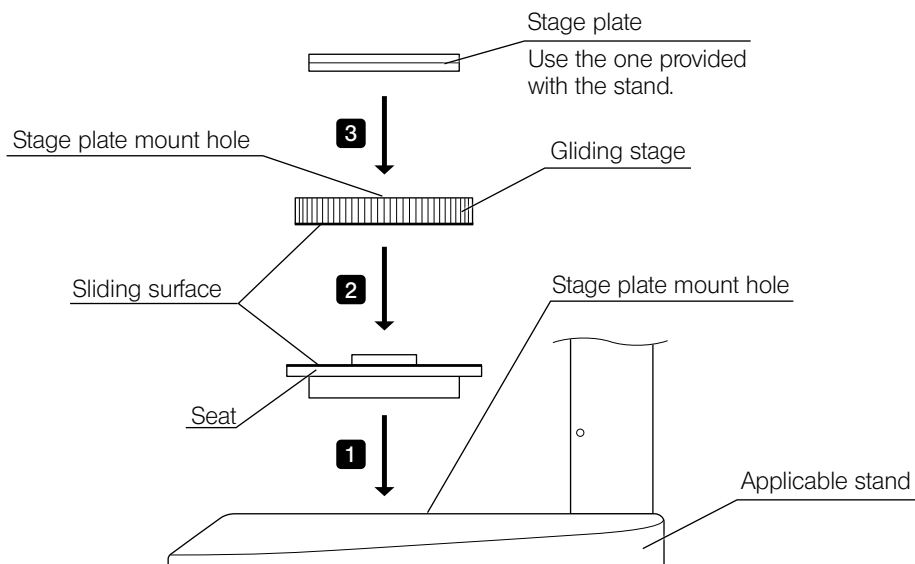

**TIP** Clean the sliding surface periodically.

### 3 Operation

Hold the gliding stage by the edge and move it horizontally.

## 9-7 Cup stage SZH-SC

### 1 External view and nomenclature

**NOTE** The SZH-SC can be used only with reflected light illumination. It cannot be used with transmitted light illumination.

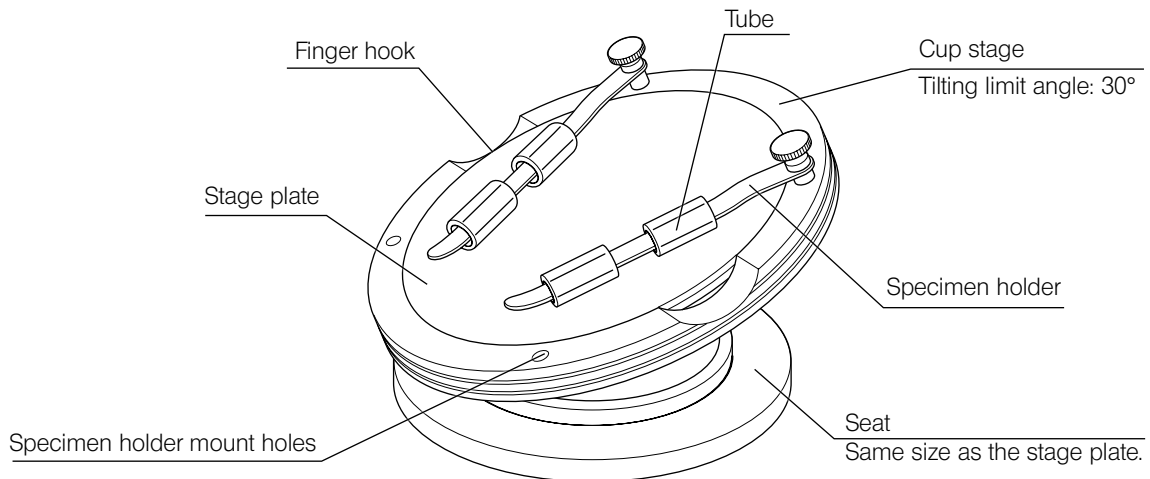

### 2 Installation

**NOTE** Before mounting, remove dirt and dust from the mount surfaces and handle carefully so as not to damage them.

**TIP** STAD mount for ILLT SZX2-STADM is necessary for using the SZX2-ILLTQ/ILLTS LED transmitted light illumination base. For details, refer to the instruction manual for the SZX2-ILLTQ/ILLTS LED.

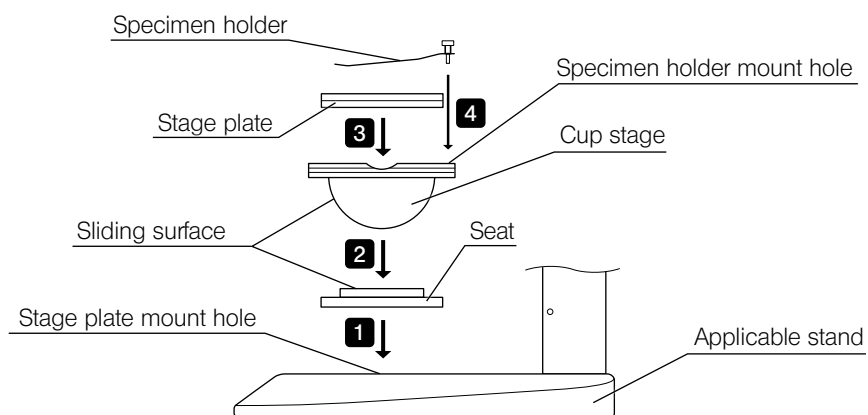

- 1** Fit the cup stage seat into the stage plate mount hole of an applicable stand.
- 2** Place the cup stage on the seat. Before placing, wipe the sliding surface on the cup stage and seat with a clean cloth.
- 3** Mount the stage plate.
- 4** Mount the specimen holder.

**TIP** Clean the sliding surface periodically.

### 3 Operation

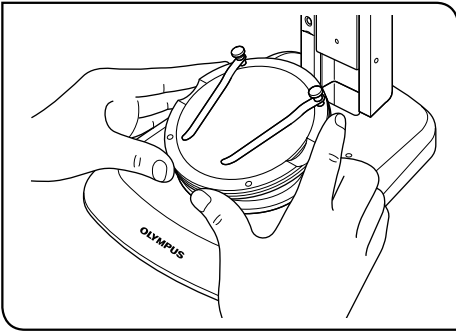

**1** Place a specimen on the stage plate, hold the cup stage by the edge, and tilt the cup stage slowly.

**TIP** If the specimen slips on the stage plate, hold the specimen with the provided specimen holder.

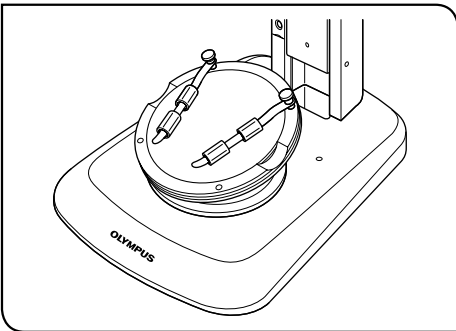

**TIP** To fix a container such as a petri dish, insert the provided tube into the specimen holder to fix the container by pinching.

- NOTE**
- Do not touch the sliding surface on the cup stage and seat with a hand. If the sliding surface are contaminated with oil, etc., wash with a neutral detergent before use.
  - If an eccentric load of more than 20 grams is applied to the edge of the cup stage, it may move spontaneously.
  - When a tall specimen is placed and the cup stage is tilted, the specimen may go out of focus. In this case, adjust the focus again.

Memo

Memo



Manufactured by



**Evident Corporation**

6666 Inatomi, Tatsuno-machi, Kamiina-gun, Nagano 399-0495, Japan

Distributed by



**Evident Europe GmbH**

Caffamacherreihe 8-10, 20355 Hamburg, Germany

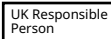

**Evident Europe GmbH – UK Branch**

Part 2nd Floor Part A, Endeavour House, Coopers End Road, Stansted CM24 1AL, UK

**Evident Scientific, Inc.**

48 Woerd Ave, Waltham, MA 02453, USA

**Evident Scientific Singapore PTE. LTD.**

#04-04/05, 25 Ubi Rd 4, UBIX Singapore 408621

**Evident Australia PTY LTD**

Level 4, 97 Waterloo Road Macquarie Park NSW 2113, Australia

**Life science solutions**

Service Center



[https://www.olympus-lifescience.com/  
support/service/](https://www.olympus-lifescience.com/support/service/)

Official website



<https://www.olympus-lifescience.com>

**Industrial solutions**

Service Center



[https://www.olympus-ims.com/  
service-and-support/service-centers/](https://www.olympus-ims.com/service-and-support/service-centers/)

Official website



<https://www.olympus-ims.com>