

INSTRUCTIONS

SZ2-STB/SZ2-STB1 SZ2-STP/SZ2-STB2 SZ2-STB3

**Arms Used with Microscopes for
Equipment Mounting**

This instruction manual is for the Olympus Arms Used with Microscopes for Equipment Mounting. To ensure the safety, obtain optimum performance and to familiarize yourself fully with the use of this equipment, we recommend that you study this manual thoroughly before operating the system. Retain this instruction manual in an easily accessible place near the work desk for future reference.

1 MODULES AND NOMENCLATURE

©All of the modules are provided with the electrostatic discharge (ESD) feature. However, the clamping knobs of the SZ2-ST5/STB2/STB3 are not provided with the ESD feature.

**Arm for SZX Stand
SZ2-ST5**

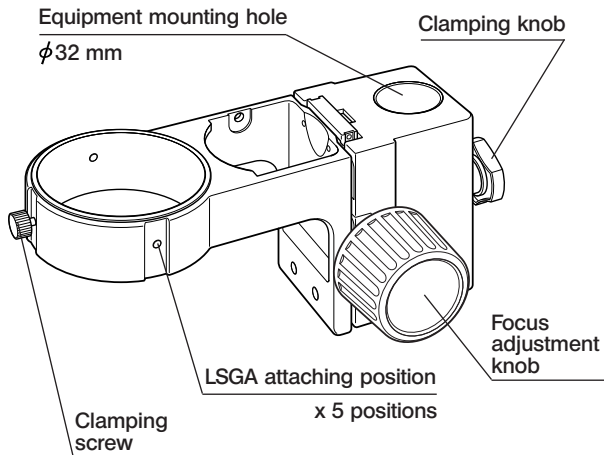

**Bonder Arm
SZ2-STB1**

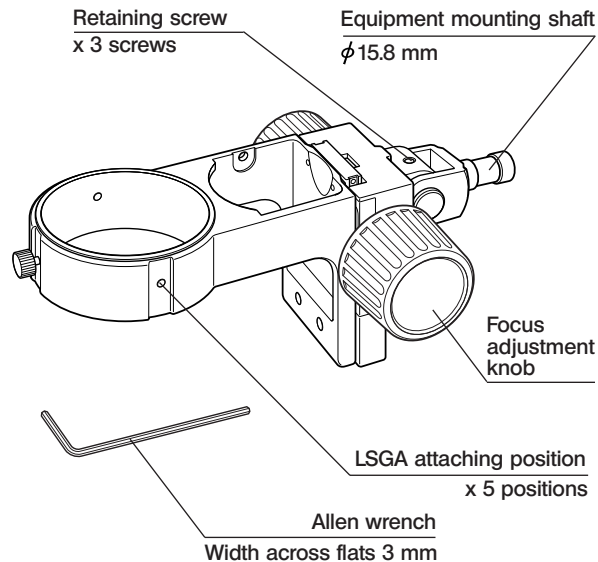

**Prober Arm
SZ2-STP**

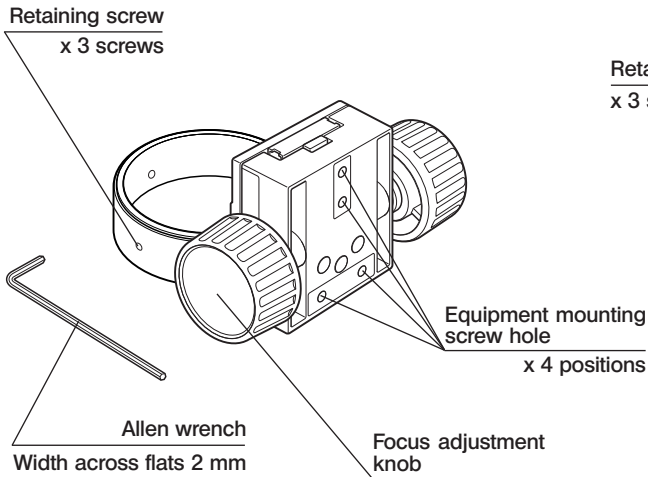

**Bonder Arm
SZ2-STB2**

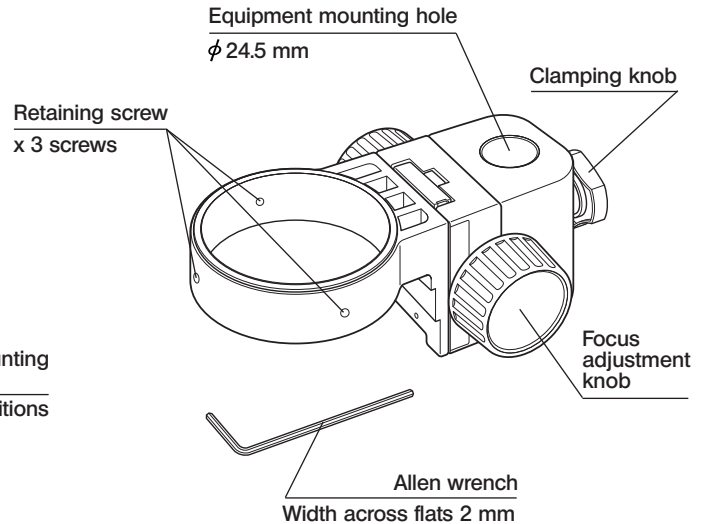

**Bonder Arm
SZ2-STB3**

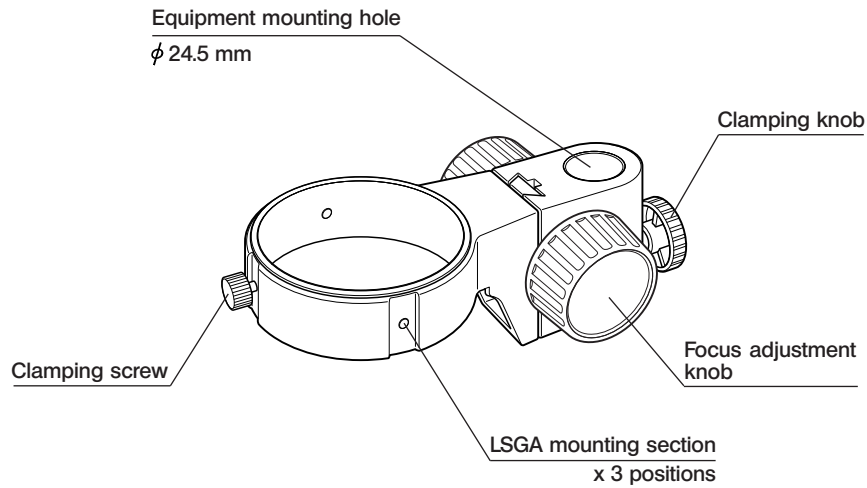

2 ASSEMBLY

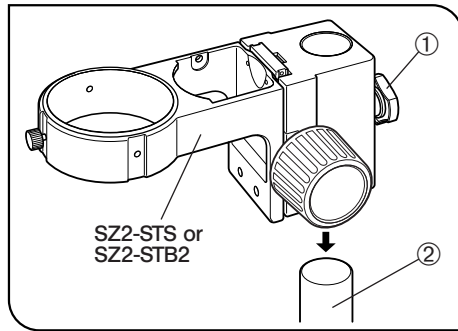

Fig. 1

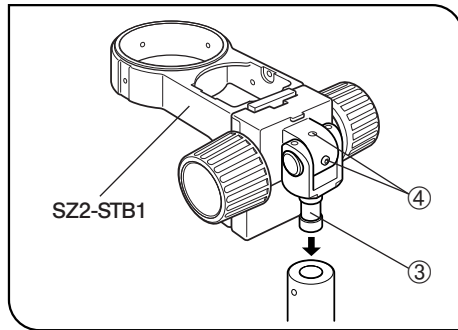

Fig. 2

1 Mounting on the Equipment

(Figs. 1 to 3)

SZ2-ST5, SZ2-STB2 or SZ2-STB3

Loosen the clamping knob ①, fit the equipment mounting hole into the pole ② of the system and tighten the clamping knob ① firmly.

- ★ **When mounting the equipment for the SZX, remove the drop-prevention ring from the stand.**
- ★ **Do not tighten the clamping knob while the pole is not inserted into the equipment mounting hole.**

SZ2-STB1

1. Loosen the clamping screw on the mount section of the equipment, insert the equipment mounting shaft ③ into the mount section, and tighten the clamping screw.
2. The equipment mounting shaft can be inserted from either up or down. When it is required to attach a heavy object such as a photography unit, it is recommended to insert the equipment mounting shaft from the upward direction.
3. To adjust the angle of the optical axis of microscope, loosen the retaining screws ④ using the provided Allen wrench, adjust the angle, and then tighten the two retaining screws that can be tightened.

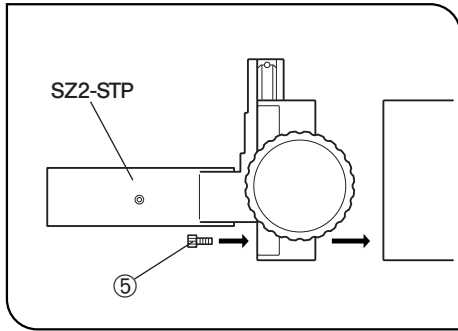

Fig. 3

SZ2-STP

Fix the equipment mounting focusing arm firmly by inserting and tightening three or more hex-socket screws ⑤.

★ Mount so that the optical axis of the microscope and surface of the specimen are not tilted.

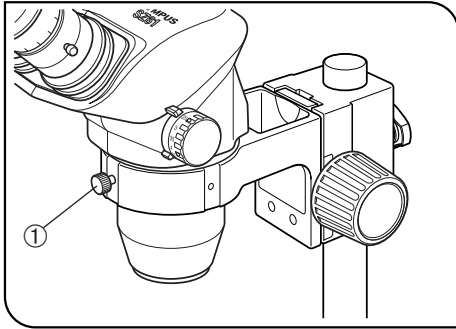

Fig. 4

2 Attaching the Microscope Frame

(Figs. 4 & 5)

SZ2-ST5, SZ2-STB1 or SZ2-STB3

1. Loosen the clamping screw ① and insert the microscope frame. The clamping screw can be attached to any of the three positions around the arm.
2. Tighten the clamping screw ① firmly.

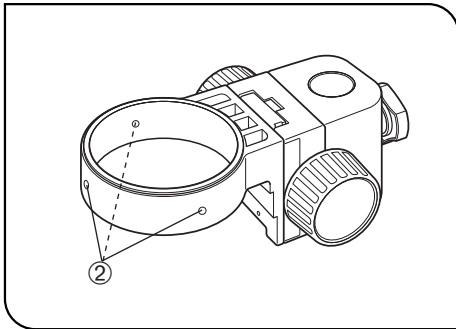

Fig. 5

SZ2-STP or SZ2-STB2

1. Using the provided Allen wrench, fully loosen the three retaining screws (hex-socket screws) ② around the arm and insert the microscope.
2. Tighten the three retaining screws firmly.

★ When an SD or SF series microscope frame is attached on the SZ2-STP or SZ2-STB2, the ring fluorescent lamp cannot be used.

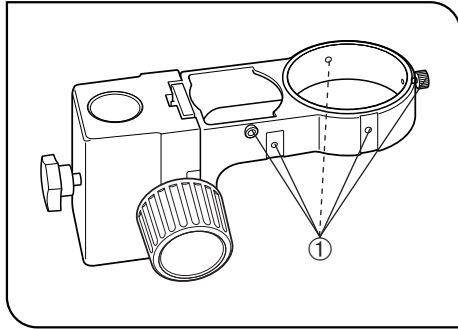

Fig. 6

3 Attaching the LSGA Illuminator

(Fig. 6)

★ The LSGA cannot be attached on the SZ2-STB2 and SZ2-STP.

Using the IHA or IHD holder, the LSGA illuminator can be attached to any of the five (or three with the SZ2-STB3 in combination with the IHA mounting holder) LSGA attaching positions ① on the arm.

For details, refer to the instruction manual for the LSGA.

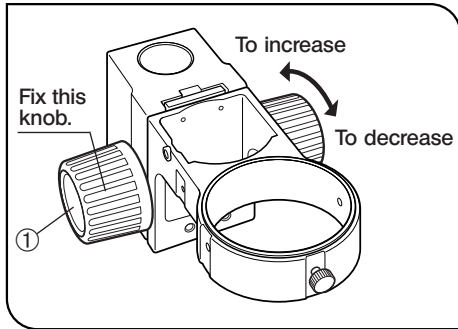

Fig. 7

4 Adjusting the Focus Adjustment Knob Tension

(Fig. 7)

1. Hold the left and right focus adjustment knobs ① with two hands, fix one knob and rotate the other knob to increase or decrease the tension according to the rotation direction.
2. This operation is intended to adjust the force required for rotating the knob while preventing spontaneous lowering of the microscope frame. To obtain highest ease of use, it is recommended to adjust the tension at a slightly higher level than the level at which spontaneous lowering occurs.

3 SPECIFICATIONS

Item	Specifications	
Model	SZ2-ST5	SZ2-STB1
Microscope attaching method	Insertion (attaching hole diameter $76^{+0.2}_0$ mm). Attaching using a clamping knob.	
Focus adjustment	Ball guide system, up/down movement with rack & pinion. Focus adjustment stroke 50 mm Focus adjustment knob tension adjustable.	
Illuminator (LSGA) attaching method	Possible using an LSGA attaching holder (IHA or IHD).	
Mounting on the equipment	Insertion (attaching hole diameter $32H8^{+0.039}_0$ mm). Mounting using a clamping knob. Load up to 7 kg.	Insertion (attaching shaft diameter $15.8 f8^{-0.016}_{-0.043}$ mm). Microscope attaching angle adjustable. Load up to 7 kg.
Weight	Approx. 1200 grams	Approx. 900 grams
Model	SZ2-STB2	SZ2-STP
Microscope attaching method	Insertion (attaching hole diameter $76^{+0.2}_0$ mm). Clamping using three hex-socket retaining screws (using the provided Allen wrench)	
Focus adjustment	Ball guide system, up/down movement with rack & pinion. Focus adjustment stroke 45 mm Focus adjustment knob tension adjustable.	
Mounting on the equipment	Insertion (attaching hole diameter $24.5^{+0.06}_{+0.01}$ mm). Mounting using a clamping knob. Load up to 7 kg.	Attaching using three or more hex-socket screws (M4x10). (Four mounting holes) Load up to 7 kg.
Weight	Approx. 800 grams	Approx. 500 grams

Item	Specifications
Model	SZ2-STB3
Microscope attaching method	Insertion (attaching hole diameter $76^{+0.2}_0$ mm). Attaching using a clamping knob.
Focus adjustment	Up/down movement with rack & pinion and dovetail guide. Focus adjustment stroke 43 mm. Focus adjustment knob tension adjustable.
Illuminator (LSGA) attaching method	Possible using an LSGA attaching holder (IHA).
Mounting on the equipment	Insertion (attaching hole diameter $24.5^{+0.06}_{+0.01}$ mm). Mounting using a clamping knob. Load up to 3 kg.
Weight	Approx. 600 grams

This product is manufactured by **EVIDENT CORPORATION** effective as of Apr. 1, 2022.
Please contact our "Service Center" through the following website for any inquiries or issues
related to this product.

EVIDENT CORPORATION

6666 Inatomi, Tatsuno-machi, Kamiina-gun, Nagano 399-0495, Japan

(Life science solutions)

Service Center

<https://www.olympus-lifescience.com/support/service/>



(Life science solutions)

Our Website

<https://www.olympus-lifescience.com>



(Industrial solutions)

Service Center

<https://www.olympus-ims.com/service-and-support/service-centers/>



(Industrial solutions)

Our Website

<https://www.olympus-ims.com>



AX7266 05

Issued in April, 2022

Printed in Japan 20220315 M0000