

INSTRUCTIONS

SZ2-STU1/SZ2-STU2 SZ2-STU3

**UNIVERSAL STAND TYPE 1
UNIVERSAL STAND TYPE 2
TABLE CLAMP STAND**

Optical Microscope Accessory

This instruction manual is for the Olympus Stands for stereo microscopes. To ensure the safety, obtain optimum performance and to familiarize yourself fully with the use of this equipment, we recommend that you study this manual thoroughly before operating the system. Retain this instruction manual in an easily accessible place near the work desk for future reference.

CONTENTS

The SZ2-STU1, SZ2-STU2 and SZ2-STU3 stands are provided with ESD (Electro-Static Discharge) protection specifications. Each stand is provided with electroconductive coating in their external finish to reduce the surface resistance. Connecting a grounding lead wire to the stand (and also the horizontal arm in case of the SZ2-STU2) makes it possible eliminate static electricity quickly.

CAUTION To maintain the ESD protection performance, always use the stand in combination with a stereo microscope, arm used with microscope for equipment mounting and options having the ESD protection specifications. Otherwise, the grounding will not work properly.

- The clamping knob of the stand is not provided with the ESD protection performance. (The clamping knob with the ESD protection performance is available on custom order.)
- With the SZ2-STU2, circuit continuity between the horizontal arm and base plate is interrupted by the friction surface of the column. These parts should be grounded individually.

CAUTION After the equipment has been used in an observation of a specimen that is accompanied with a potential of infection, clean the parts coming in contact with the specimen to prevent infection.

©Intended use

This instrument has been designed to be used to observe magnified images of specimens in routine and research applications.

Do not use this instrument for any purpose other than its intended use.

SZ2-STU1/SZ2-STU3

IMPORTANT – Be sure to read this section for safe use of the equipment. – 1-2

1	MODULES, EXTERNAL VIEW AND DIMENSIONS	3
2	NOMENCLATURE AND ASSEMBLY	4
3	OPERATION	5-6

SZ2-STU2

IMPORTANT – Be sure to read this section for safe use of the equipment. – 7

1	MODULES, EXTERNAL VIEW AND DIMENSIONS	8
2	NOMENCLATURE AND ASSEMBLY	9-10
3	OPERATION	11-13

SZ2-STU1 / SZ2-STU3

IMPORTANT

⚠ SAFETY PRECAUTIONS

SZ2-STU1

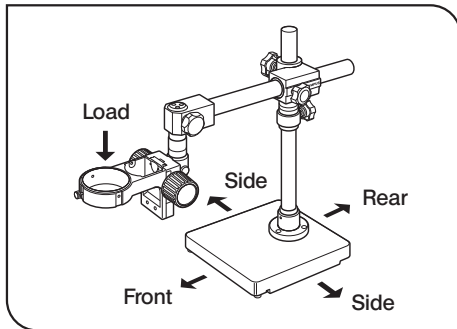

Fig. 1

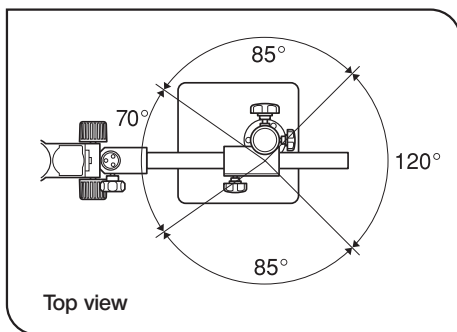

Fig. 2

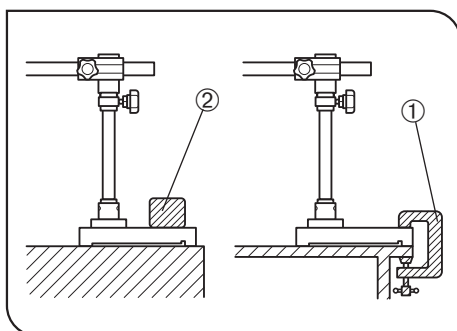

Fig. 3

1. Install the stand on a level desktop (inclination angle of less than 3°).
2. When moving the stand, make sure that the clamping mechanisms are secured tightly and lift the stand by holding it by the base plate. If the stand is held by the horizontal arm or column alone, the base plate may drop.
3. The load of the stand is limited (see table below). A heavy object such as a photography unit cannot be used. The column is attached at a position deviated from the center of the base plate.

The safety of the stand varies depending on the orientation of the horizontal arm. (Figs. 1 & 2)

When the horizontal arm is extended at maximum, the load to the bonder arm is limited as shown in the following table.

Front 70°	Max. 4.6 kg
Side 85°	Max. 3.0 kg
Rear 120°	Max. 2.0 kg

*** Under this condition, the stand tends to topple down easily if another load is applied during the microscope operation. It is recommended to set the horizontal arm as short as possible.**

The horizontal arm is most stable when it is oriented in the front 70° range shown in Fig. 2.

4. When a wide space is required in front of the microscope, the horizontal arm should often be oriented in the rear 120° range and the stand tends to topple down easily. In this case, fix the stand firmly by using a table clamp ① or placing a weight (3 kg or more) ② on the base plate. (Fig. 3)

SZ2-STU3

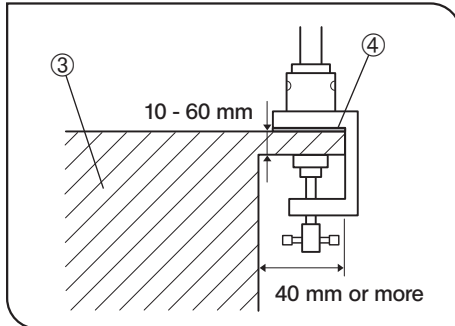

Fig. 4

1. Install the stand on a sturdy table ③ having thickness of 10 to 60 mm and edge space length of 40 mm or more. (Fig. 4)
2. The load capacity is 4.6 kg regardless of the orientation.
3. Before installing or uninstalling the stand on or from the table, remove the column from the table clamp to secure safety.
If you do not remove the column, always have another person hold the horizontal arm section.
4. If internal oscillations are troublesome, insert the provided rubber sheet ④ below the stand. (Fig. 4)

SZ2-STU1/SZ2-STU3

1 MODULES, EXTERNAL VIEW AND DIMENSIONS (Unit: mm)

**Universal Stand Type 1
SZ2-STU1**

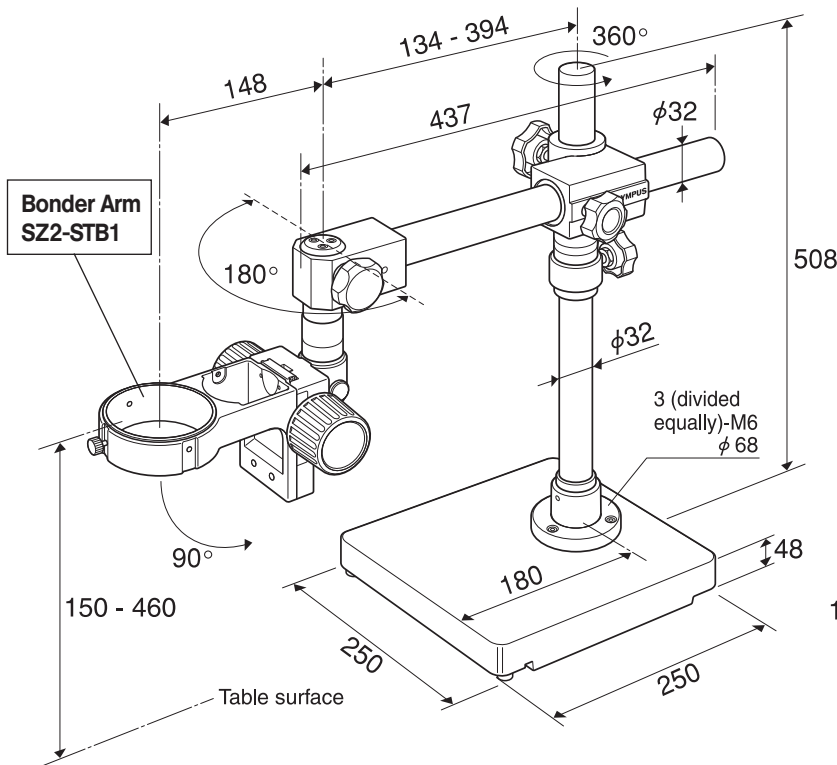

- Base plate weight: 17.5 kg
- Total weight: 25.4 kg (including the 0.9 kg bonder arm)

**Table Clamp Stand
SZ2-STU3**

(The shaded parts are identical to the SZ2-STU1.)

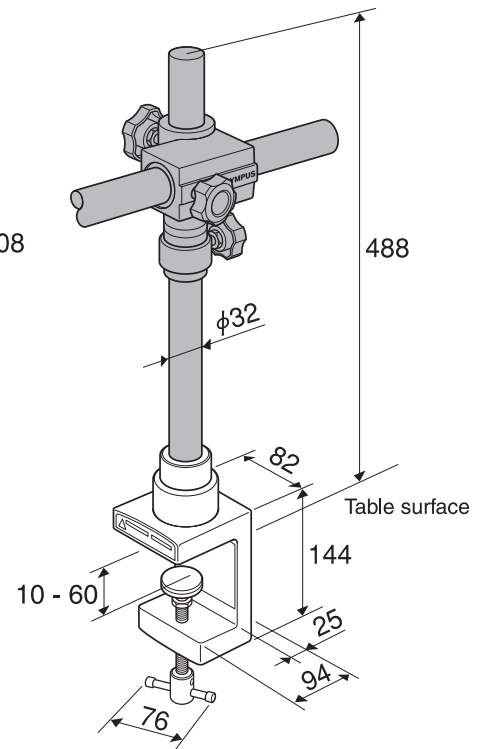

- Clamp section weight: 2 kg
- Total weight: 9.9 kg (including the 0.9 kg bonder arm)

Mountable Modules

©To maintain the ESD protection performance, the following modules should also be provided with the ESD protection performance.

- Microscope body: SZ2 series, SZX7, SZ series or SD/SF series
- Oblique illumination system: LSGA (mountable on the SZ2-STB1)
- Other modules mounted on the microscope body

CAUTION From the viewpoint of safety, it is prohibited to mount the photography unit on the stand.

2 NOMENCLATURE AND ASSEMBLY

1 Assembling the Stand

(Fig. 5)

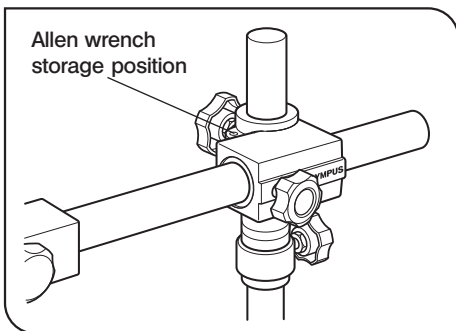
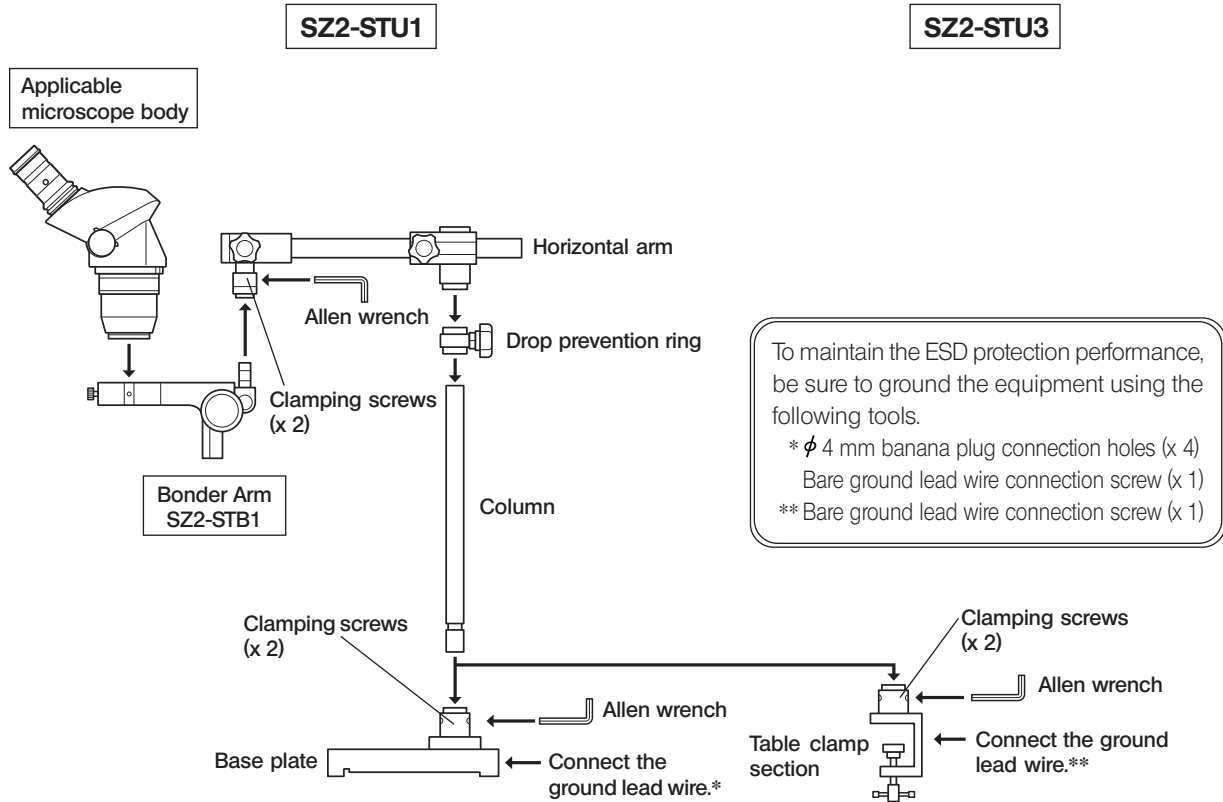

Fig. 5

- ▲ Attach the column by firmly tightening the screws using the Allen wrench.
- ▲ Insert the drop prevention ring below the horizontal arm, in close contact with it.
- ◎ It is convenient to store the Allen wrench in the Allen wrench storage position on the horizontal arm for future use.

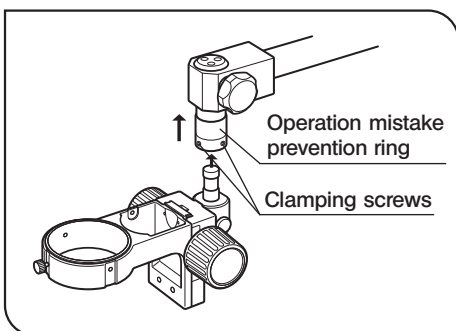

Fig. 6

2 Attaching the Bonder Arm

(Fig. 6)

1. Lift the operation mistake prevention ring on the shaft at the distal end of the horizontal arm, and screw in the provided clamping screws into the two screw holes by about half using the Allen wrench. Insert the bonder arm from the bottom side all the way up until it is stopped.
 2. Tighten the clamping screws firmly using the Allen wrench. When you remove your hand from the operation mistake prevention ring, it drops to hide the screws.
- ▲ Be sure to attach the bonder arm firmly with the screws. Otherwise, it may rotate or drop and cause danger.

3 OPERATION

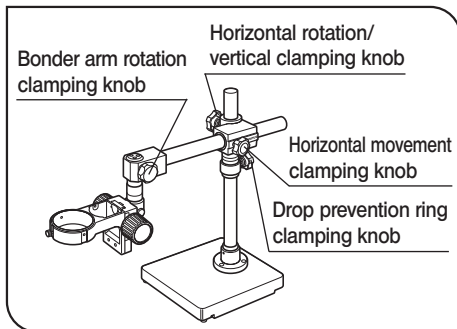

Fig. 7

1. To move the horizontal arm horizontally along the arm shaft, loosen the horizontal movement clamping knob. Lift the microscope slightly for smooth movement.

2. To rotate the horizontal arm by 360° around the column, loosen the horizontal rotation clamping knob.

When rotating the horizontal arm, confirm that the drop prevention ring clamping knob is tightened firmly and in close contact with the horizontal arm section.

3. To move the horizontal arm upward, keep the drop prevention ring clamping knob tightened but loosen the vertical clamping knob. After lifting the horizontal arm to the desired position, tighten the vertical clamping knob again. And then move up the drop prevention ring till immediately beneath the horizontal arm section and clamp the ring again.

To move the horizontal arm downward, always move down and clamp the drop prevention ring before moving the horizontal arm downward.

▲ Never loosen two clamping knobs simultaneously, as this is extremely dangerous.

4. To rotate the bonder arm horizontally, loosen the bonder arm rotation clamping knob. (Fig. 8)

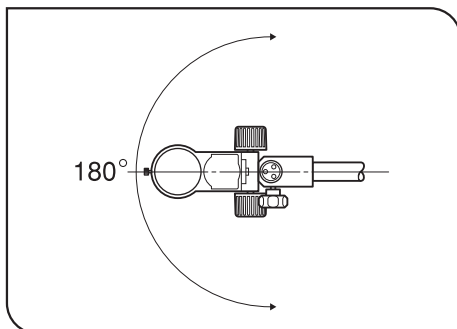

Fig. 8

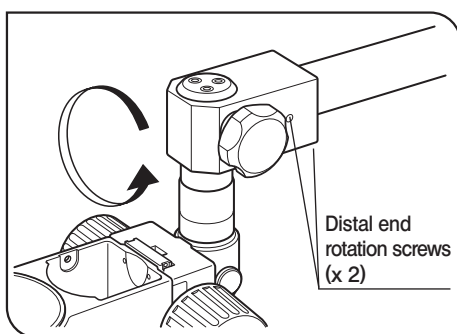

Fig. 9

5. To rotate the distal end of the horizontal arm with respect to the arm, loosen the two screws at the distal end using the provided Allen wrench. (Fig. 9)

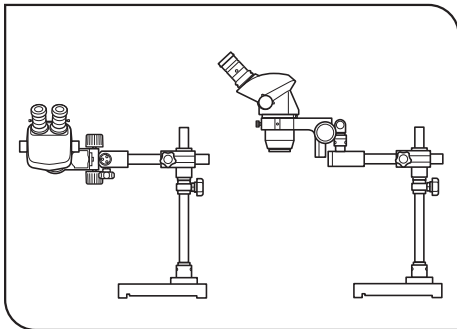

Fig. 10

Rotating the distal end enables observation of a perpendicular plane or tall specimen. (Fig. 10)

- ▲ Be particularly sure to tighten the distal end rotation screws tightly. If they are loose, the distal end may rotate suddenly.
- ▲ Do not tighten the distal end rotation screws too much, as this may cause the distal end to slip out of the horizontal arm.
- ▲ The stability is degraded if the distal end is attached on the side or above the horizontal arm. In this case, take care to increase the stability of the base plate.

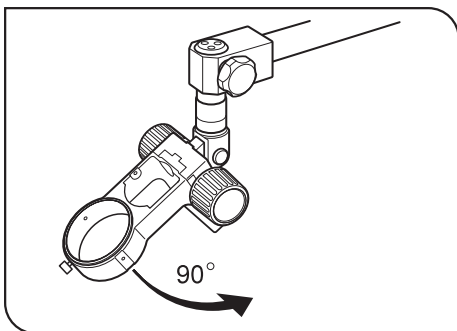

Fig. 11

6. To change the angle of the bonder arm, loosen the bonder arm angle adjustment screw. (Fig. 11)

For the adjustment of the bonder arm angle, read the instruction manual for the Arm Used with Microscope for Equipment Mounting.

- ▲ Do not adjust the angle while the microscope body is mounted. Dismount it before the adjustment.

SZ2-STU2

IMPORTANT

! SAFETY PRECAUTIONS

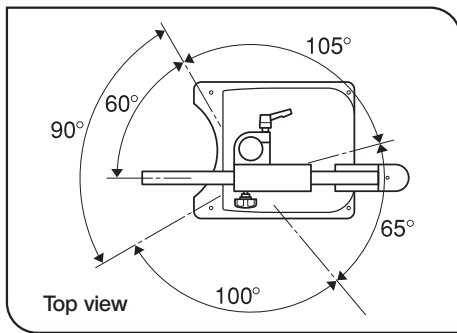

Fig. 12

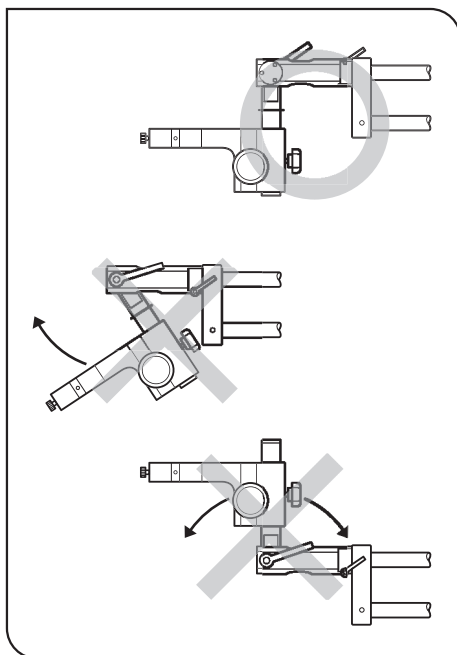

Fig. 13

1. Install the stand on a level desktop (inclination less than 3°).
2. When moving the stand, make sure that the clamping mechanisms are secured tightly and lift the stand by holding it by the base plate. If the stand is held by the horizontal arm or column alone, the base plate may drop.
3. The load of the stand is limited, and its stability is variable depending on the orientation of the horizontal arm. (Fig. 12)
 - When the horizontal arm is extended at maximum, the load to the arm of the SZX stand arm is limited as shown in the following table.*

Front 90°	Max. 10 kg (Max. 8.8 kg)
Left side 105°	Max. 6 kg (Max. 4.8 kg)
Right side 100°	Max. 6 kg (Max. 4.8 kg)
Rear 65°	Max. 7 kg (Max. 5.8 kg)

***Under this condition, the stand tends to topple down easily if another load is applied during the microscope operation. It is recommended to set the horizontal arm as short as possible.**

The figures inside () are the loads when the SZX stand arm, weighing 1.2 kg, is used.

- When the mounted microscope is heavy, set the horizontal arm rotation stopper for the front 90° positioning. (For the method of this operation, see page 11)
4. When the mounted microscope has a TV camera or photography unit mounted on it, do not tilt the microscope body. As the microscope is heavy and the center of gravity of the system is located high, loosening the clamping lever may cause the microscope to rotate suddenly, causing damage to the TV camera, photography unit or microscope body. (Fig. 13) (For the method of this operation, see page 13)

2 NOMENCLATURE AND ASSEMBLY

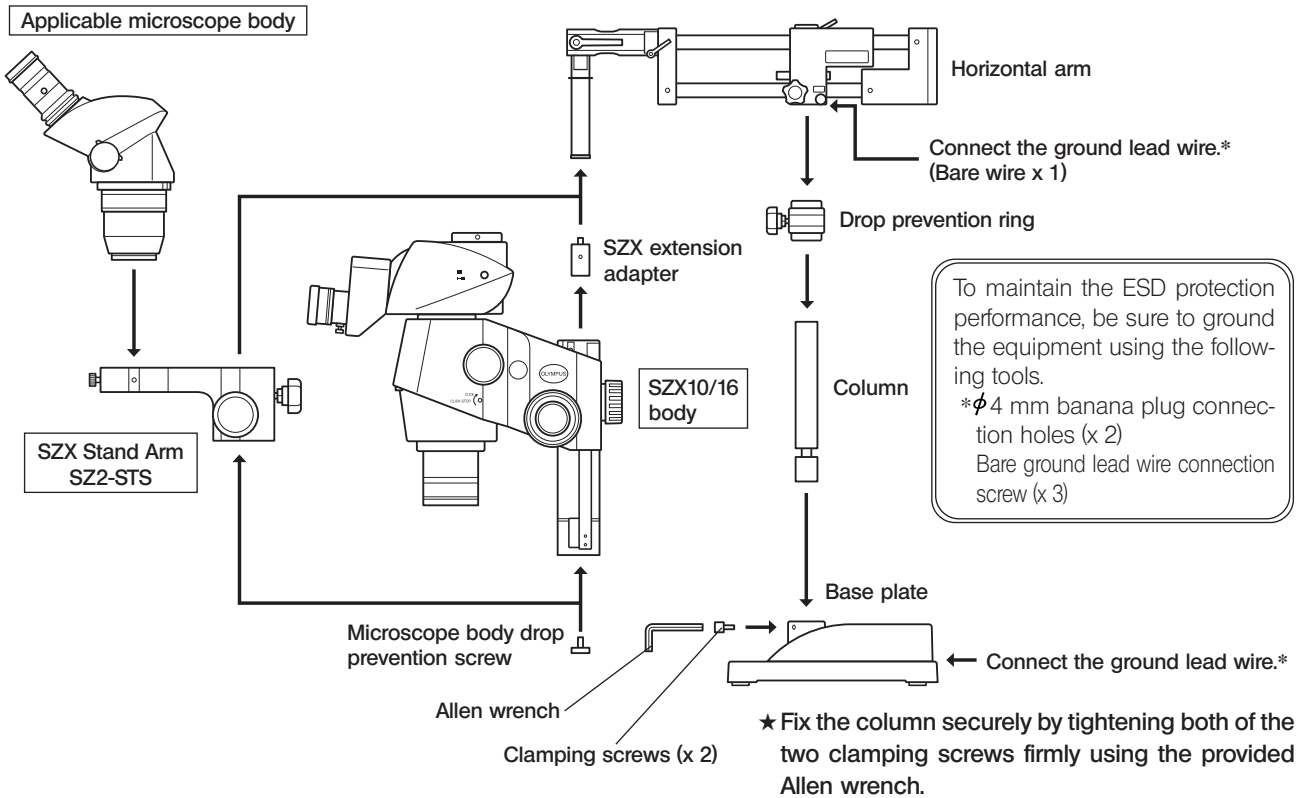
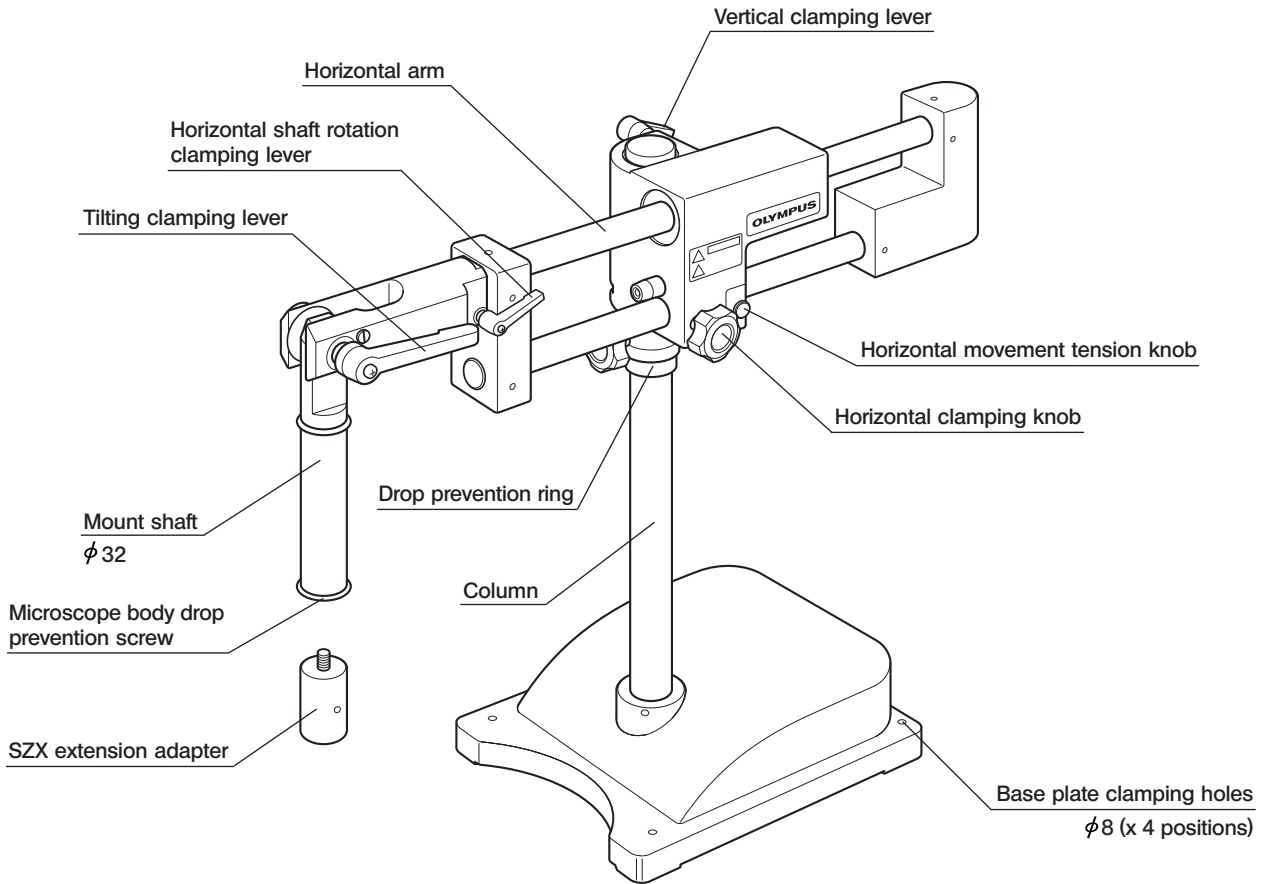

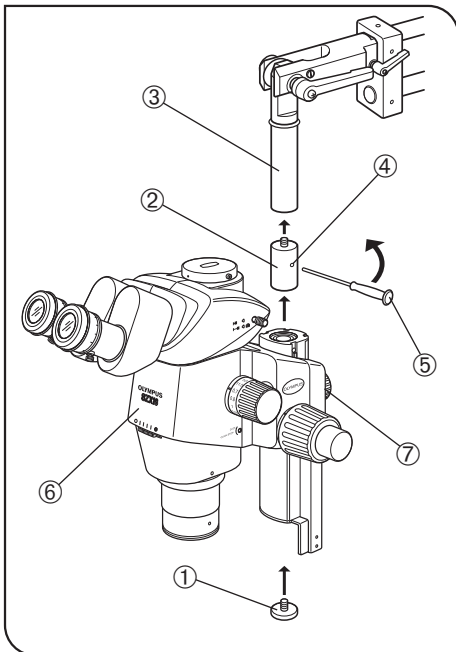

Fig. 14

1 Installing an Applicable Microscope Body (Fig. 14)

1. Remove the microscope body drop prevention screw ① and screw the SZX extension adapter ② into the mount shaft ③.
2. Insert the Allen screwdriver ⑤, provided with the SZX microscope body, into the hole ④ on the center of the extension adapter ② and rotate the screwdriver in the direction of the arrow to clamp the extension adapter firmly.
3. Mount the SZX microscope body ⑥ and tighten the focusing assembly clamping knob ⑦.
4. Screw in the microscope body drop prevention screw ① tightly using a coin.

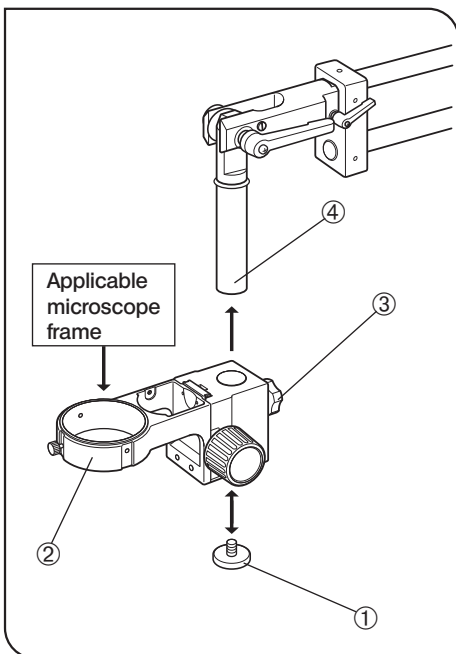

Fig. 15

2 Installing SZX Stand Arm SZ2-ST5 (Fig. 15)

1. Remove the microscope body drop prevention screw ①, loosen the clamping knob ③ of the SZ2-ST5 ②, attach the SZ2-ST5 to the mount shaft ④ and tighten the clamping knob ③.
2. Screw in the microscope body drop prevention screw ① tightly using a coin.
3. Mount the applicable microscope body to be used.

3 OPERATION

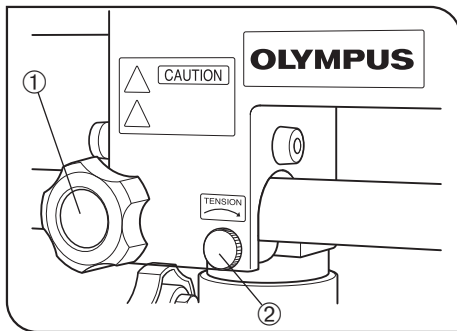

Fig. 16

1. To move the horizontal arm horizontally, loosen the horizontal clamping knob ①.

The tension of the horizontal movement can be adjusted with the horizontal movement tension adjustment knob ②. Rotating the knob in the direction of the arrow increases the tension and rotating in the opposite direction decreases it. (Fig.16)

▲ Do not decrease the tension too much, as too quick movement may pinch your hand and cause injury.

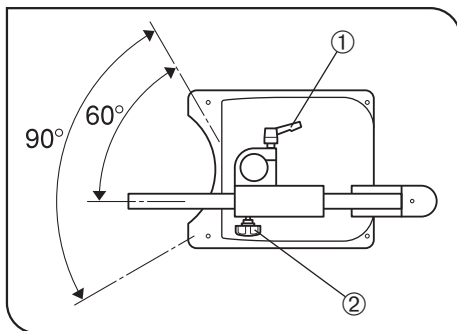

Fig. 17

2. To rotate the horizontal arm around the column, loosen the vertical clamping lever ①. This rotation is limited to 90° by the rotation stopper of the drop prevention ring. The rotation range can be set to the front 90° range, which renders the system most stable, by orienting the clamping knob ② of the drop prevention ring so that it points the front of the stand. (Fig. 17)

▲ To ensure safety, use the most stable rotation range unless other range is required for a special purpose.

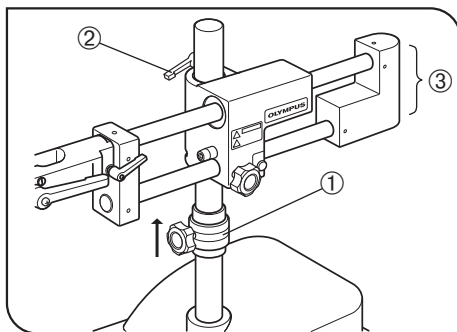

Fig. 18

3. To move the horizontal arm upward, keep the drop prevention ring ① clamped but loosen the vertical clamping lever ②. After lifting the horizontal arm ③ to the desired position, tighten the vertical clamping lever again. And then move up the drop prevention ring till immediately beneath the horizontal arm section and clamp the ring again.

To move the horizontal arm downward, confirm that the vertical clamping lever ② is clamped and move down and clamp the drop prevention ring. And then, holding the horizontal arm, loosen the vertical clamping lever and move down the horizontal arm gently.

▲ Never loosen the clamping knob of the drop prevention ring ① and vertical clamping lever ② simultaneously, as this is extremely dangerous.

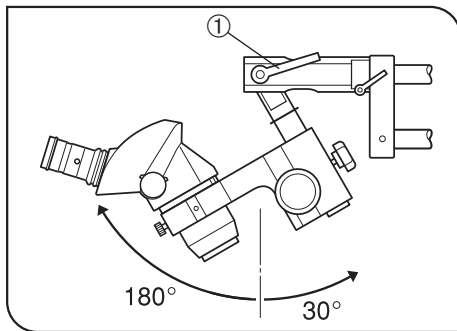

Fig. 19

4. To tilt the microscope body to the front or rear, loosen the tilting clamping lever ①. (Fig. 19)

▲ Loosen the lever only by half when tilting the microscope body. If the lever is loosened completely, the microscope body may turn suddenly and cause danger.

▲ When a photography unit or TV camera is mounted on the microscope body, do not attempt to tilt it.

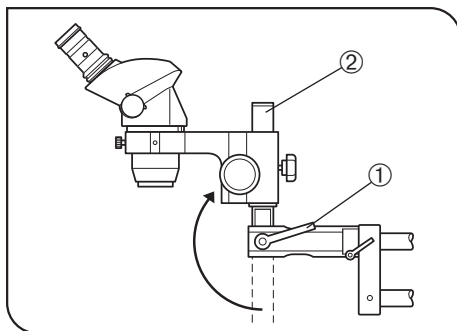

Fig. 20

5. When observing a tall specimen or using an auxiliary objective with long working distance, loosen the tilting clamping lever ①, revolve the mount shaft ② by 180° so that it points upward, and mount the microscope body above the horizontal arm. (Fig. 20)

▲ In this case, the stability is deteriorated extremely. Do not mount a heavy microscope body (SZX) in this way or mount a photographic unit on the microscope body mounted in this way.

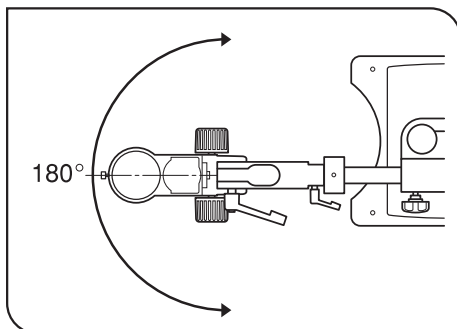

Fig. 21

6. To rotate the microscope body horizontally, loosen the clamping mechanism of the SZX stand arm or SZX microscope body. (Fig. 21)

▲ The microscope body can be rotated by 180°, or by 90° to the both left and right. However, do not rotate it too much to prevent collision.

▲ When rotating the microscope body, be careful not to loosen the drop prevention screw below it.

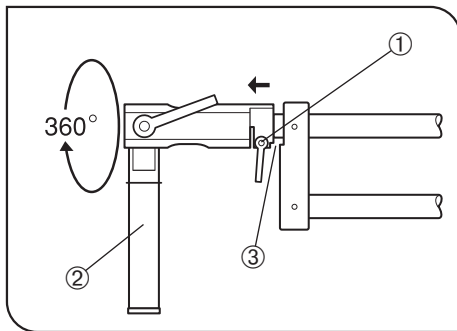

Fig. 22

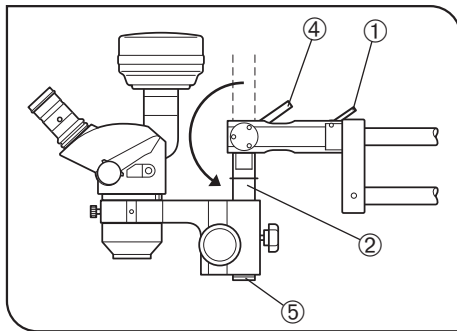

Fig. 23

7. To rotate the mount shaft ② around the horizontal shaft, loosen the horizontal shaft rotation clamping lever ①.

When the clamping lever ① is loosened and the distal end is withdrawn by 2 to 3 mm, the rotation stoppers ③ are disengaged. After rotating the mount shaft to the desired position, tighten the lever firmly to clamp the mount shaft again. (Fig. 22)

▲ **Do not withdraw the distal end too much. It would be dangerous if the distal end is completely disengaged.**

▲ **Loosen the lever only by half. If the lever is loosened completely, the microscope body may turn suddenly and cause danger.**

◎ There are two rotation stoppers, above and below the mount shaft.

8. When mounting a photography unit, use the following procedure. Take care so that the mount shaft is not tilted beyond the vertical positioning.

▲ **If the tilting clamping lever ④ gets loose while the photography unit or TV camera is mounted, it may topple down toward the observer. To prevent this danger, be sure to perform the following setup.**

a. Loosen the horizontal shaft rotation clamping lever ①, withdraw the distal end of the arm by 2 to 3 mm, and rotate the distal end by 180° so that the mount shaft ② faces upward.

Then, while applying the distal end of the arm to the rotation stoppers, tighten the clamping lever ①. (Figs. 22 & 23)

b. Loosen the tilting clamping lever ④ and set the mount shaft ② so that it faces downward. (Fig. 23)

c. Remove the microscope body drop prevention screw ⑤ and mount the SZX stand arm SZ2-ST5 or SZX microscope body. (Fig. 23)

d. After mounting the microscope body, be sure to attach the microscope body drop prevention screw ⑤. (Fig. 23)

MEMO

MEMO

This product is manufactured by **EVIDENT CORPORATION** effective as of Apr. 1, 2022.
Please contact our "Service Center" through the following website for any inquiries or issues related to this product.

EVIDENT CORPORATION

6666 Inatomi, Tatsuno-machi, Kamiina-gun, Nagano 399-0495, Japan

(Life science solutions)

Service Center

<https://www.olympus-lifescience.com/support/service/>



(Life science solutions)

Our Website

<https://www.olympus-lifescience.com>



(Industrial solutions)

Service Center

<https://www.olympus-ims.com/service-and-support/service-centers/>



(Industrial solutions)

Our Website

<https://www.olympus-ims.com>

