

IX3-TV1XTL

T-mount camera adapter 1x



SPECIFICATIONS

Global item code / Local code for USA	N5228100 / U-V360
Predecessor product information	None
Product Category	Video Camera Port
Magnification (Focal length)	1X (-)
Projection Area	ø26.5 mm (In combinations with OFN26.5 Objectives) However, the value may be less than this value depending on combinations with objectives, illuminators, intermediate attachments, etc.
Focal Plane Position	Refer to MAIN DIMENSION
Mounting Method for tube	Circular dovetail (fixing with a tool)
Mounting Method for Video Camera	T-Mount
Parfocality adjustment of imaging device	±2 mm Adjustment by moving the mount by rotating the screw thread
Centering adjustment	None
Weight	About 245 g
Country of Origin	Japan

SYSTEM ENVIRONMENT LIMITATIONS FOR OPERATION

Environment	Indoor use
Temperature T0 [°C]	5 – 40
Humidity RH0 [%]	30 – 85

IX3-TV1XTL

RESTRICTIONS

Optical performance may deteriorate when an objective lens other than UIS2 is combined.

Optical performance may deteriorate depending on the combination with a laser.

Vignetting may occur depending on the length of the intermediate tube.

PACKING LIST

Item	Quantity
Adapter unit	1

MAIN DIMENSION

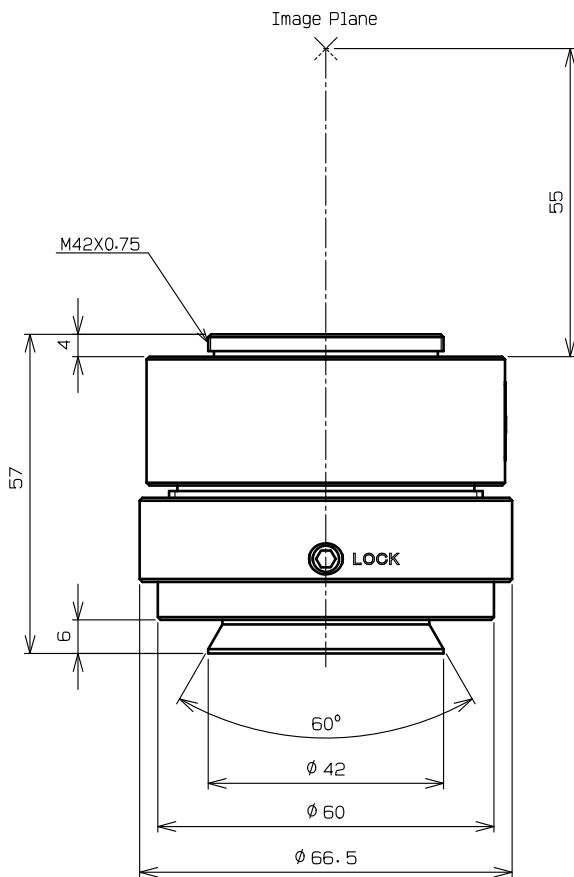

(Unit: mm)

· Specifications and appearances are subject to change without any notice or obligation on the part of the manufacturer.