



# OmniScan MX, MX1, and MX2 Multitechnology Flaw Detector

User's Manual

DMTA-20015-01EN [U8778402] — Rev. R  
September 2022

This instruction manual contains essential information on how to use this Evident product safely and effectively. Before using this product, thoroughly review this instruction manual. Use the product as instructed. Keep this instruction manual in a safe, accessible location.

EVIDENT CANADA, 3415, Rue Pierre-Ardouin, Québec (QC) G1P 0B3 Canada

Copyright © 2022 by Evident. All rights reserved. No part of this publication may be reproduced, translated, or distributed without the express written permission of Evident.

This document was prepared with particular attention to usage to ensure the accuracy of the information contained therein, and corresponds to the version of the product manufactured prior to the date appearing on the title page. There could, however, be some differences between the manual and the product if the product was modified thereafter.

The information contained in this document is subject to change without notice.

Part number: DMTA-20015-01EN [U8778402]

Rev. R

September 2022

Printed in Canada

The microSD Logo is a trademark of SD-3C, LLC. The SD Logo is a trademark of SD-3C, LLC.



All brands are trademarks or registered trademarks of their respective owners and third party entities.

---

---

# Table of Contents

---

<b>List of Abbreviations .....</b>	<b>9</b>
<b>Important Information – Please Read Before Use .....</b>	<b>11</b>
Intended Use .....	11
Instruction Manual .....	11
Device Compatibility .....	12
Repair and Modification .....	12
Safety Symbols .....	12
Safety Signal Words .....	13
Note Signal Words .....	14
Safety .....	14
Warnings .....	14
Battery Precautions .....	15
Regulations for Shipping Products with Lithium-Ion Batteries .....	17
Equipment Disposal .....	17
BC (Battery Charger - California, USA Community) .....	17
CE (European Community) .....	18
UKCA (United Kingdom) .....	18
RCM (Australia) .....	18
WEEE Directive .....	18
China RoHS .....	19
Korea Communications Commission (KCC) .....	20
EMC Directive Compliance .....	20
FCC (USA) Compliance .....	21
ICES-001 (Canada) Compliance .....	22
Warranty Information .....	22
Technical Support .....	23

<b>OmniScan MX2 .....</b>	<b>25</b>
<b>Introduction .....</b>	<b>27</b>
<b>1. Overview of the Equipment .....</b>	<b>29</b>
1.1 Front Panel of the OmniScan MX2 .....	29
1.1.1 Display Touch Screen .....	30
1.1.2 Main Control Area .....	30
1.1.3 Power Key .....	31
1.1.4 Increment Keys .....	31
1.1.5 Help Key .....	32
1.1.6 Indicator Lights .....	32
1.1.6.1 Power Indicator Light .....	32
1.1.6.2 Acquisition Indicator Light .....	33
1.1.6.3 Alarm Indicator Lights .....	33
1.2 Right Side Panel .....	34
1.3 Left Side Panel .....	35
1.4 Top Panel .....	36
1.5 Rear Panel .....	37
<b>2. Basic Operation .....</b>	<b>39</b>
2.1 Turning On and Off the OmniScan MX2 .....	39
2.2 Automatic Start-Up Mode .....	41
2.3 Power Supply Management .....	41
2.3.1 DC Power Adaptor .....	42
2.3.2 Lithium-Ion Batteries .....	43
2.3.3 Battery Status Indicators .....	43
2.3.4 Battery Removal and Installation .....	45
2.3.5 Battery Charging .....	46
2.3.6 Maximizing the Performance of Lithium-Ion Batteries .....	47
2.3.7 Used Battery Disposal .....	48
2.3.8 Warnings on Battery Use .....	48
2.4 Peripheral Connection .....	49
2.5 OmniScan MX2 Software Installation .....	53
<b>3. Maintenance .....</b>	<b>55</b>
3.1 Preventative Maintenance .....	55
3.2 Instrument Cleaning .....	55
3.2.1 Casing and Acquisition Module Cleaning .....	55
3.2.2 Screen and Screen Protector Cleaning .....	57
3.3 Replacing the Touch-Screen Protector .....	58

<b>4. Troubleshooting .....</b>	<b>59</b>
4.1 Start-Up Problems .....	59
4.2 Message .....	59
4.3 Battery Charging Problems .....	60
4.4 Battery Life Problems .....	60
<b>5. Specifications .....</b>	<b>63</b>
<b>6. Connector References .....</b>	<b>67</b>
6.1 Serial Connector .....	68
6.2 Scanner Interface Connector .....	69
6.3 Alarm and I/O Connector .....	72
<b>OmniScan MX and OmniScan MX1 .....</b>	<b>75</b>
<b>Introduction .....</b>	<b>77</b>
Available and Discontinued Products .....	77
OmniScan MX / MX1 Features .....	78
<b>7. Overview of the Equipment .....</b>	<b>81</b>
7.1 Front Panel of the OmniScan MX / MX1 .....	81
7.1.1 Main Control Area .....	82
7.1.2 Function Keys .....	83
7.1.3 Power Key .....	84
7.1.4 Up and Down Keys .....	85
7.1.5 Menu Key .....	85
7.1.6 Submenu Keys .....	85
7.1.7 Help Key .....	85
7.1.8 Parameter Keys .....	86
7.1.9 Indicator Lights .....	86
7.1.9.1 Keypad Indicator Light .....	86
7.1.9.2 Power Indicator Light .....	86
7.1.9.3 Acquisition Indicator Light .....	87
7.1.9.4 Alarm Indicator Lights .....	88
7.2 Right Side Panel .....	88
7.3 Left Side Panel .....	90
7.4 Top Panel .....	91
7.5 Rear Panel .....	91
<b>8. Basic Operation .....</b>	<b>93</b>
8.1 Turning On and Off the OmniScan MX / MX1 .....	93

8.2	Power Supply Management .....	94
8.2.1	DC Power Adaptor .....	94
8.2.2	Lithium-Ion Batteries .....	95
8.2.3	Battery Status Indicators .....	96
8.2.4	Battery Removal and Installation .....	97
8.2.5	Battery Charging .....	98
8.2.6	Maximizing the Performance of Lithium-Ion Batteries .....	99
8.2.7	Used Battery Disposal .....	100
8.2.8	Warnings on Battery Use .....	100
8.3	Peripheral Connection .....	101
8.4	OmniScan Software Installation .....	104
<b>9.</b>	<b>Maintenance .....</b>	<b>107</b>
9.1	Preventative Maintenance .....	107
9.2	Instrument Cleaning .....	107
9.2.1	Casing and Acquisition Module Cleaning .....	107
9.2.2	LCD Screen Protector Cleaning .....	108
<b>10.</b>	<b>Troubleshooting .....</b>	<b>109</b>
10.1	Start-Up Problems .....	109
10.2	Messages .....	109
10.3	Battery Charging Problems .....	110
10.4	Battery Life Problems .....	110
10.5	Memory Card Problems .....	111
10.6	Headphone or Speaker Problems .....	112
10.6.1	Internal Speaker .....	112
10.6.2	Headphones or External Speakers .....	112
10.7	Video Input Problems .....	112
10.8	Video Output Problems .....	113
10.9	Networking Problems .....	113
10.10	USB Peripheral Problems .....	114
10.11	Boot Problems .....	114
10.11.1	A-Scan Display .....	114
10.11.2	OmniScan MX / MX1 Start-Up .....	115
<b>11.</b>	<b>Specifications .....</b>	<b>117</b>
<b>12.</b>	<b>Connector References .....</b>	<b>121</b>
12.1	Serial Connector .....	122
12.2	Scanner Interface Connector .....	123
12.3	Alarm and I/O Connector .....	126

---

<b>Appendix A: Compatibility Tables .....</b>	<b>129</b>
<b>Appendix B: Acquisition Module Description and Replacement</b>	
<b>Procedures .....</b>	<b>133</b>
B.1 General Specifications .....	133
B.2 Connectors .....	136
B.3 Replacement Procedure .....	137
B.4 Fan Filter Cleaning Procedure .....	138
<b>Appendix C: OMNI-M-PA32128 Module Specifications .....</b>	<b>141</b>
C.1 Acoustic Specifications .....	142
C.2 Acquisition Specifications .....	143
C.3 Data Specifications .....	143
<b>Appendix D: OMNI-M-UT-2C, OMNI-M-UT-4C, and</b>	
<b>OMNI-M-UT-8C Module Specifications .....</b>	<b>145</b>
D.1 Acoustic Specifications .....	146
D.2 Acquisition Specifications .....	147
D.3 Data Specifications .....	147
<b>Appendix E: OMNI-M-PA1616M and OMNI-M-PA1664M Module</b>	
<b>Specifications .....</b>	<b>149</b>
E.1 Acoustic Specifications .....	150
E.2 Acquisition Specifications .....	151
E.3 Data Specifications .....	152
<b>Appendix F: OMNI-M-PA1616 Module Specifications .....</b>	<b>153</b>
F.1 Acoustic Specifications .....	154
F.2 Acquisition Specifications .....	155
F.3 Data Specifications .....	156
<b>Appendix G: OMNI-M-PA16128 Module Specifications .....</b>	<b>157</b>
G.1 Acoustic Specifications .....	158
G.2 Acquisition Specifications .....	159
G.3 Data Specifications .....	159
<b>Appendix H: OMNI-M-PA16128PR Module Specifications .....</b>	<b>161</b>
H.1 Acoustic Specifications .....	162
H.2 Acquisition Specifications .....	163
H.3 Data Specifications .....	164

---

<b>Appendix I: OMNI-M-PA32128PR Module Specifications .....</b>	<b>165</b>
I.1 Acoustic Specifications .....	166
I.2 Acquisition Specifications .....	167
I.3 Data Specifications .....	167
<b>Appendix J: OMNI-M-PA3232 Module Specifications .....</b>	<b>169</b>
J.1 Acoustic Specifications .....	170
J.2 Acquisition Specifications .....	171
J.3 Data Specifications .....	171
<b>Appendix K: OMNI-M-PA1664 Module Specifications .....</b>	<b>173</b>
K.1 Acoustic Specifications .....	174
K.2 Acquisition Specifications .....	175
K.3 Data Specifications .....	176
<b>Appendix L: OMNI-M-ECA4-32 and OMNI-M1-ECA4-32 Module Specifications .....</b>	<b>177</b>
L.1 ECA Acquisition Module Description .....	177
L.2 ECA Acquisition Module Receptacles .....	178
L.3 Probe Connectors .....	179
L.4 4CH Connector References .....	181
L.5 ECA Acquisition Module Specifications .....	182
L.5.1 General Specifications .....	183
L.5.2 Generator and Receiver .....	183
L.5.3 Data .....	184
<b>Appendix M: OMNI-M2-PA1664/16128/32128/32128PR Module Specifications .....</b>	<b>187</b>
M.1 Acoustic Specifications .....	190
M.2 Acquisition Specifications .....	192
M.3 Data Specifications .....	193
<b>Appendix N: OMNI-M2-UT-2C Module Specifications .....</b>	<b>195</b>
N.1 Acoustic Specifications .....	197
N.2 Acquisition Specifications .....	198
N.3 Data Specifications .....	198
<b>List of Figures .....</b>	<b>201</b>
<b>List of Tables .....</b>	<b>203</b>



---

## List of Abbreviations

---

DC	direct current
ECA	Eddy current array
ECT	Eddy current testing
EFUP	environment-friendly use period
FS	full speed
HS	high speed
NDT	nondestructive testing
P/N	part number
PA	phased array
RH	relative humidity
SDHC	Secure Digital High Capacity
TFT	thin film transistor
UT	ultrasonic testing
VDC	volts direct current
WEEE	waste electrical and electronic equipment



---

## Important Information — Please Read Before Use

---

### Intended Use

The OmniScan MX / MX1 is designed to perform nondestructive inspections on industrial and commercial materials.



#### **WARNING**

Do not use the OmniScan MX / MX1 for any purpose other than its intended use. It must never be used to inspect or examine human or animal body parts.

---

### Instruction Manual

This instruction manual contains essential information on how to use this product safely and effectively. Before using this product, thoroughly review this instruction manual. Use the product as instructed. Keep this instruction manual in a safe, accessible location.

---

#### **IMPORTANT**

Some of the details of components illustrated in this manual may differ from the components installed on your device. However, the operating principles remain the same.

---

## Device Compatibility

Only use this device with the approved ancillary equipment provided by Evident. Equipment provided by Evident and approved for use with this device is described later in this manual.

---



### CAUTION

Always use equipment and accessories that meet Evident specifications. Using incompatible equipment could cause equipment malfunction and/or damage, or human injury.

---

## Repair and Modification

This device does not contain any user-serviceable parts. Opening the device might void the warranty.

---



### CAUTION

In order to prevent human injury and/or equipment damage, do not disassemble, modify, or attempt to repair the device.

---

## Safety Symbols

The following safety symbols might appear on the device and in the instruction manual:



General warning symbol

This symbol is used to alert the user to potential hazards. All safety messages that follow this symbol shall be obeyed to avoid possible harm or material damage.

---



High voltage warning symbol

This symbol is used to alert the user to potential electric shock hazards greater than 1000 volts. All safety messages that follow this symbol shall be obeyed to avoid possible harm.

## Safety Signal Words

The following safety symbols might appear in the documentation of the device:



**DANGER**

The DANGER signal word indicates an imminently hazardous situation. It calls attention to a procedure, practice, or the like, which, if not correctly performed or adhered to, will result in death or serious personal injury. Do not proceed beyond a DANGER signal word until the indicated conditions are fully understood and met.



**WARNING**

The WARNING signal word indicates a potentially hazardous situation. It calls attention to a procedure, practice, or the like, which, if not correctly performed or adhered to, could result in death or serious personal injury. Do not proceed beyond a WARNING signal word until the indicated conditions are fully understood and met.



**CAUTION**

The CAUTION signal word indicates a potentially hazardous situation. It calls attention to an operating procedure, practice, or the like, which, if not correctly performed or adhered to, may result in minor or moderate personal injury, material damage, particularly to the product, destruction of part or all of the product, or loss of data. Do not proceed beyond a CAUTION signal word until the indicated conditions are fully understood and met.

## Note Signal Words

The following note signal words could appear in the documentation of the device:

**IMPORTANT**

The IMPORTANT signal word calls attention to a note that provides important information, or information essential to the completion of a task.

**NOTE**

The NOTE signal word calls attention to an operating procedure, practice, or the like, which requires special attention. A note also denotes related parenthetical information that is useful, but not imperative.

**TIP**

The TIP signal word calls attention to a type of note that helps you apply the techniques and procedures described in the manual to your specific needs, or provides hints on how to effectively use the capabilities of the product.

## Safety

Before turning on the device, verify that the correct safety precautions have been taken (see the following warnings). In addition, note the external markings on the device, which are described under “Safety Symbols.”

## Warnings



**WARNING**

### General Warnings

- Carefully read the instructions contained in this instruction manual prior to turning on the device.
- Keep this instruction manual in a safe place for further reference.

- Follow the installation and operation procedures.
- It is imperative to respect the safety warnings on the device and in this instruction manual.
- If the equipment is used in a manner not specified by the manufacturer, the protection provided by the equipment could be impaired.
- Do not install substitute parts or perform any unauthorized modification to the device.
- Service instructions, when applicable, are for trained service personnel. To avoid the risk of electric shock, do not perform any work on the device unless qualified to do so. For any problem or question regarding this device, contact Evident or an authorized Evident representative.
- Do not touch the connectors directly by hand. Otherwise, a malfunction or electric shock may result.
- Do not allow metallic or foreign objects to enter the device through connectors or any other openings. Otherwise, a malfunction or electric shock may result.



### **WARNING**

#### **Electrical Warning**

The device must only be connected to a power source corresponding to the type indicated on the rating label.



### **CAUTION**

If a non-approved power supply cord not dedicated to Evident products is used, Evident will not be able to ensure the electrical safety of the equipment.

#### **Battery Precautions**



### **CAUTION**

- Before disposing of a battery, check your local laws, rules, and regulations, and follow them accordingly.

- Transportation of lithium-ion batteries is regulated by the United Nations under the United Nations Recommendations on the Transport of Dangerous Goods. It is expected that governments, intergovernmental organizations, and other international organizations shall conform to the principles laid down in these regulations, thus contributing to worldwide harmonization in this field. These international organizations include the International Civil Aviation organization (ICAO), the International Air Transport Association (IATA), the International Maritime Organization (IMO), the US Department of Transportation (USDOT), Transport Canada (TC), and others. Please contact the transporter and confirm current regulations before transportation of lithium-ion batteries.
- For California (USA) only:  
The device may contain a CR battery. The CR battery contains perchlorate material, and special handling may be required. Refer to <http://www.dtsc.ca.gov/hazardouswaste/perchlorate>.
- Do not open, crush, or perforate batteries; doing so could cause injury.
- Do not incinerate batteries. Keep batteries away from fire and other sources of extreme heat. Exposing batteries to extreme heat (over 80 °C) could result in an explosion or personal injury.
- Do not drop, hit, or otherwise abuse a battery, as doing so could expose the cell contents, which are corrosive and explosive.
- Do not short-circuit the battery terminals. A short circuit could cause injury and severe damage to a battery making it unusable.
- Do not expose a battery to moisture or rain; doing so could cause an electric shock.
- Only use an external charger approved by Evident to charge the batteries.
- Only use batteries supplied by Evident.
- Do not store batteries that have less than 40 % remaining charge. Recharge batteries to between 40 % and 80 % capacity before storing them.
- During storage, keep the battery charge between 40 % and 80 %.
- Do not leave batteries in the OmniScan MX / MX1 unit during device storage.



## Regulations for Shipping Products with Lithium-Ion Batteries

---

### IMPORTANT

When shipping a Li-ion battery or batteries, be sure to follow all local transportation regulations.

---



### WARNING

Damaged batteries cannot be shipped through normal routes — DO NOT ship damaged batteries to Evident. Contact your local Evident representative or material disposal professionals.

---

## Equipment Disposal

Before disposing of the OmniScan MX / MX1, check your local laws, rules, and regulations, and follow them accordingly.

## BC (Battery Charger - California, USA Community)



The BC marking indicates that this product has been tested and complies with the Appliance Efficiency Regulations as stated in the California Code of Regulations Title 20, Sections 1601 through 1608 for Battery Charger Systems. The internal battery charger within this device has been tested and certified pursuant to the California Energy Commission's (CEC) requirements; this device is listed on the online CEC's (T20) database.

## CE (European Community)



This device complies with the requirements of directive 2014/30/EU concerning electromagnetic compatibility, directive 2014/35/EU concerning low voltage, and directive 2015/863 which amends 2011/65/EU concerning restriction of hazardous substances (RoHS). The CE marking is a declaration that this product conforms to all the applicable directives of the European Community.

## UKCA (United Kingdom)



This device complies with the requirements of the Electromagnetic Compatibility Regulations 2016, the Electrical Equipment (Safety) Regulations 2016, and the Restriction of the Use of Certain Hazardous Substances in Electrical and Electronic Equipment Regulations 2012. The UKCA marking indicates compliance with the above regulations.

## RCM (Australia)



The regulatory compliance mark (RCM) label indicates that the product complies with all applicable standards, and has been registered with the Australian Communications and Media Authority (ACMA) for placement on the Australian market.

## WEEE Directive



In accordance with European Directive 2012/19/EU on Waste Electrical and Electronic Equipment (WEEE), this symbol indicates that the product must not be disposed of as unsorted municipal waste, but should be collected separately. Refer to your local Evident distributor for return and/or collection systems available in your country.



## China RoHS

*China RoHS* is the term used by industry generally to describe legislation implemented by the Ministry of Information Industry (MII) in the People's Republic of China for the control of pollution by electronic information products (EIP).



The China RoHS mark indicates the product's Environment-Friendly Use Period (EFUP). The EFUP is defined as the number of years for which listed controlled substances will not leak or chemically deteriorate while in the product. The EFUP for the OmniScan MX / MX1 has been determined to be 15 years.

**Note:** The Environment-Friendly Use Period (EFUP) is not meant to be interpreted as the period assuring functionality and product performance.



本标志是根据“电器电子产品有害物质限制使用管理办法”以及“电子电气产品有害物质限制使用标识要求”的规定，适用于在中国销售的电器电子产品上的电器电子产品有害物质使用限制标志。

电器电子产品有  
害物质限制使用  
标志

(注意) 电器电子产品有害物质限制使用标志内的数字为在正常的使用条件下有害物质等不泄漏的期限，不是保证产品功能性能的期间。

产品中有害物质的名称及含量

部件名称		有害物质					
		铅及其化合物 (Pb)	汞及其化合物 (Hg)	镉及其化合物 (Cd)	六价铬及其化合物 (Cr( VI ))	多溴联苯 (PBB)	多溴二苯醚 (PBDE)
主体	机构部件	×	○	○	○	○	○
	光学部件	×	○	○	○	○	○
	电气部件	×	○	○	○	○	○

产品中有害物质的名称及含量

部件名称	有害物质					
	铅及其化合物 (Pb)	汞及其化合物 (Hg)	镉及其化合物 (Cd)	六价铬及其化合物 (Cr( VI ))	多溴联苯 (PBB)	多溴二苯醚 (PBDE)
附件	×	○	○	○	○	○

本表格依据 SJ/T 11364 的规定编制。  
○：表示该有害物质在该部件所有均质材料中的含量均在 GB/T26572 规定的限量要求以下。  
×：表示该有害物质至少在该部件的某一均质材料中的含量超出 GB/T26572 规定的限量要求。

## Korea Communications Commission (KCC)



Seller and user shall be noticed that this equipment is suitable for electromagnetic equipment for office work (class A) and it can be used outside the home. This device complies with the EMC requirements of Korea.

The MSIP code for the OmniScan MX2 is the following:  
MSIP-REM-OYN-OMNIMX2.

이 기기는 업무용 환경에서 사용할 목적으로 적합성평가를 받은 기기로서 가정용 환경에서 사용하는 경우 전파간섭의 우려가 있습니다.

## EMC Directive Compliance

This equipment generates and uses radio-frequency energy and, if not installed and used properly (that is, in strict accordance with the manufacturer's instructions), may cause interference. The OmniScan MX / MX1 has been tested and found to comply with the limits for an industrial device in accordance with the specifications of the EMC directive.

## FCC (USA) Compliance

---

<b>NOTE</b>
-------------

This product has been tested and found to comply with the limits for a Class A digital device, pursuant to Part 15 of the FCC Rules. These limits are designed to provide reasonable protection against harmful interference when the product is operated in a commercial environment. This product generates, uses, and can radiate radio frequency energy, and if not installed and used in accordance with the instruction manual, might cause harmful interference to radio communications. Operation of this product in a residential area is likely to cause harmful interference, in which case you will be required to correct the interference at your own expense.

---

---

<b>IMPORTANT</b>
------------------

Changes or modifications not expressly approved by the party responsible for compliance could void the user's authority to operate the product.

---

### FCC Supplier's Declaration of Conformity

Hereby declares that the product,

Product name: OmniScan MX / MX1

Model: OmniScan MX / MX1-MR/OmniScan MX / MX1-CW

Conforms to the following specifications:

FCC Part 15, Subpart B, Section 15.107 and Section 15.109.

Supplementary information:

This device complies with Part 15 of the FCC Rules. Operation is subject to the following two conditions:

- (1) This device may not cause harmful interference.
- (2) This device must accept any interference received, including interference that may cause undesired operation.

Responsible party name:

EVIDENT CANADA

Address:

3415, Rue Pierre-Ardouin Québec (QC) G1P 0B3 Canada

Phone number:

+1 781-419-3900

## **ICES-001 (Canada) Compliance**

This Class A digital apparatus complies with Canadian ICES-001.

Cet appareil numérique de la classe A est conforme à la norme NMB-001 du Canada.

## **Warranty Information**

Evident guarantees your Evident product to be free from defects in materials and workmanship for a specific period, and in accordance with conditions specified in the Terms and Conditions available at <https://www.olympus-ims.com/en/terms/>.

The Evident warranty only covers equipment that has been used in a proper manner, as described in this instruction manual, and that has not been subjected to excessive abuse, attempted unauthorized repair, or modification.

Inspect materials thoroughly on receipt for evidence of external or internal damage that might have occurred during shipment. Immediately notify the carrier making the delivery of any damage, because the carrier is normally liable for damage during shipment. Retain packing materials, waybills, and other shipping documentation needed in order to file a damage claim. After notifying the carrier, contact Evident for assistance with the damage claim and equipment replacement, if necessary.

This instruction manual explains the proper operation of your Evident product. The information contained herein is intended solely as a teaching aid, and shall not be used in any particular application without independent testing and/or verification by the operator or the supervisor. Such independent verification of procedures becomes increasingly important as the criticality of the application increases. For this reason, Evident makes no warranty, expressed or implied, that the techniques, examples, or procedures described herein are consistent with industry standards, nor that they meet the requirements of any particular application.

Evident reserves the right to modify any product without incurring the responsibility for modifying previously manufactured products.

## **Technical Support**

Evident is firmly committed to providing the highest level of customer service and product support. If you experience any difficulties when using our product, or if it fails to operate as described in the documentation, first consult the user's manual, and then, if you are still in need of assistance, contact our After-Sales Service. To locate the nearest service center, visit the Service Centers page on the Evident Scientific Web site.





# OmniScan MX2

Model no. OMNI-MX2



---

## Introduction

---

Evident is a long-standing leader in NDT (nondestructive testing) multimodular test platforms, with thousands of OmniScan MX instruments in use throughout the world. The second-generation OmniScan MX2 increases testing efficiencies, ensuring superior manual and advanced automatic ultrasonic testing (AUT) application performance with faster setups, test cycles, and reporting, in addition to universal compatibility with all phased array modules: past, present, and future. Designed for NDT phased array leaders, this high-end, highly evolved platform delivers true next-generation NDT testing.

The first part of this manual contains descriptions and instructions for using the OmniScan MX2. Information about compatible acquisition modules is provided in “Compatibility Tables” on page 129; however, this manual only covers the description and basic operation of the instrument. For information concerning inspection applications, please refer to the *OmniScan MXU Software User’s Manual*.

The second part of this manual contains descriptions and instructions for using the OmniScan MX and OmniScan MX1 instrument models (see “OmniScan MX and OmniScan MX1” on page 75).

---

<b>NOTE</b>
-------------

Refer to the *OmniScan MXU Software User’s Manual* for information on software functions.

---

---

**NOTE**

The illustrations used in this manual were prepared with the instrument version available at the time of publication, and may differ slightly in appearance from the version of the OmniScan MX2 instrument that you are using.

---

---

# 1. Overview of the Equipment

---

This chapter describes the physical characteristics of the OmniScan MX2, which features a modular design. To find out which modules are compatible with the OmniScan MX2, see “Compatibility Tables” on page 129. Each module is also detailed in the appendices at the end of this manual.

## 1.1 Front Panel of the OmniScan MX2

The front panel of the OmniScan MX2 (Figure 1-1 on page 30) contains all the main controls and indicators. This panel is divided into different areas, which are explained further in the following sections.

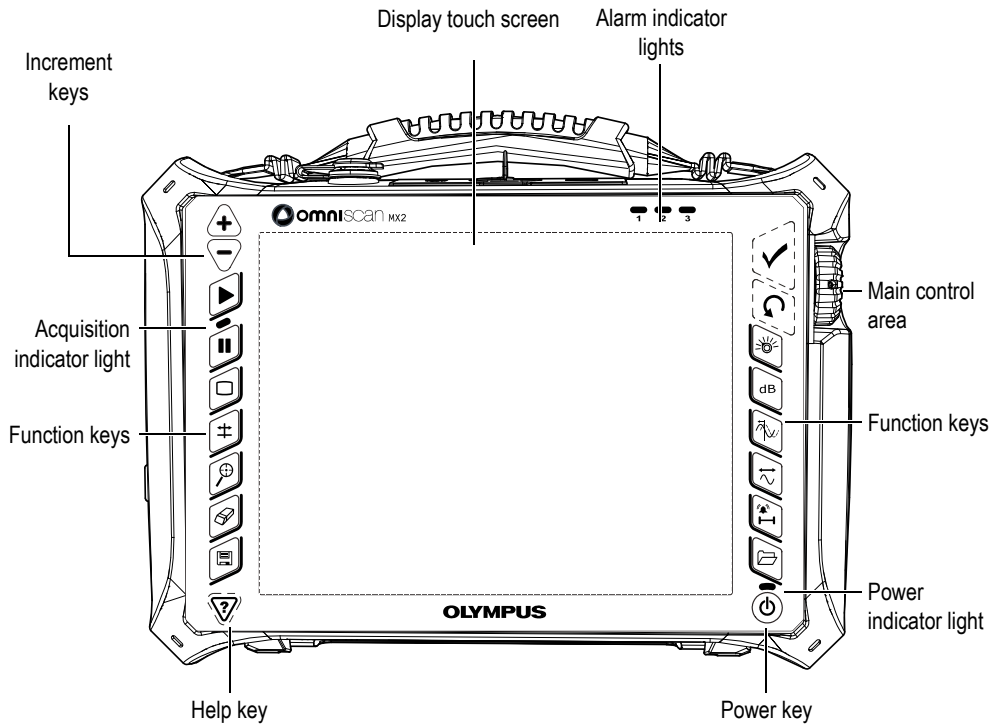

**Figure 1-1 Front panel of the OmniScan MX2**



### 1.1.1 Display Touch Screen

The display touch screen acts as a pointing device. To click an interface element, touch the screen surface lightly with your finger. To drag an interface element, just slide your fingertip across the screen surface. Refer to the *OmniScan MXU Software User's Manual* for advanced operating instructions for the touch screen.

### 1.1.2 Main Control Area

The main control area is shown in Figure 1-1 on page 30. You can control the OmniScan MX2 completely from this area if you wish. The main control area contains three elements, which are described in Table 1 on page 31.

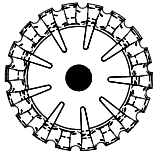
**Table 1 Main control area**

Element	Name	Description
	Scroll knob	Used to navigate through selections without the need for a keyboard, mouse, or touch screen. Turning the scroll knob in a clockwise direction shifts a selection to the left (horizontal list) or upward (vertical list). For more information about using the scroll knob with the OmniScan software, refer to the <i>Evident OmniScan MXU Software User's Manual</i> .
	Cancel key	Used to cancel the current selection, or to go back one level in the menu hierarchy.
	Accept key	Used to confirm a selection.

### 1.1.3 Power Key

Power key ()

Used to start or shut down the OmniScan MX2.

### 1.1.4 Increment Keys

The increment keys can be used to turn the full-screen mode on or off when not in edit mode.

Raise increment key ()

Used to turn on the full-screen mode or to increase the increment step.

Lower increment key (  )

Used to turn off the full-screen mode or to lower the increment step.

### 1.1.5 Help Key

The Help key is shaped in the form of an inverted triangle, and located on the lower-left side of the OmniScan MX2 front panel.

Help key (  )

Pressing this key displays the online help for the currently selected function.

### 1.1.6 Indicator Lights

There are three types of indicator lights on the OmniScan MX2 front panel: power, acquisition, and alarm. Each indicator light is described below.

#### 1.1.6.1 Power Indicator Light

The power indicator light is located above the Power key (  ). The color of this light identifies the power status of the OmniScan MX2 (Table 2 on page 32).

**Table 2 Power indicator light statuses**

Off	The OmniScan MX2 is turned off.
Flashing orange	The OmniScan MX2 is turned off. Batteries are charging.
Orange	The OmniScan MX2 is turned off. Battery charging is complete.
Green	<ul style="list-style-type: none"><li>• The OmniScan MX2 is turned on.</li><li>• The OmniScan MX2 is turned on and batteries are charging.</li></ul>
Flashing green/orange	The OmniScan MX2 is in sleep mode. Batteries are charging.



**Table 2 Power indicator light statuses (continued)**

Flashing green	<ul style="list-style-type: none"> <li>The OmniScan MX2 is in sleep mode.</li> <li>The OmniScan MX2 is in sleep mode and battery charging is complete.</li> </ul>
Flashing red	A critical factor (excessive temperature, very weak batteries, etc.) requires immediate attention.

### 1.1.6.2 Acquisition Indicator Light

The acquisition indicator light is located below the Play key (). The color of this light indicates the operating mode of the OmniScan MX2 (Table 3 on page 33).

**Table 3 Acquisition indicator light statuses**

Off	Oscilloscope mode acquisition
Orange	Freeze analysis mode

---

#### IMPORTANT

The OmniScan MX2 must be turned off before the acquisition module is installed or removed.

---

### 1.1.6.3 Alarm Indicator Lights

There are three alarm indicator lights (numbered 1, 2, and 3) located on the upper right corner of the OmniScan MX2. These lights only flash one color (red) and indicate the trigger status of their respective alarms (set within the software).

---

#### NOTE

For more details about the alarm indicator lights, refer to the *OmniScan MXU Software User's Manual*.

---

## 1.2 Right Side Panel

The right side panel of the OmniScan MX2 (Figure 1-2 on page 34) contains various input and output ports.

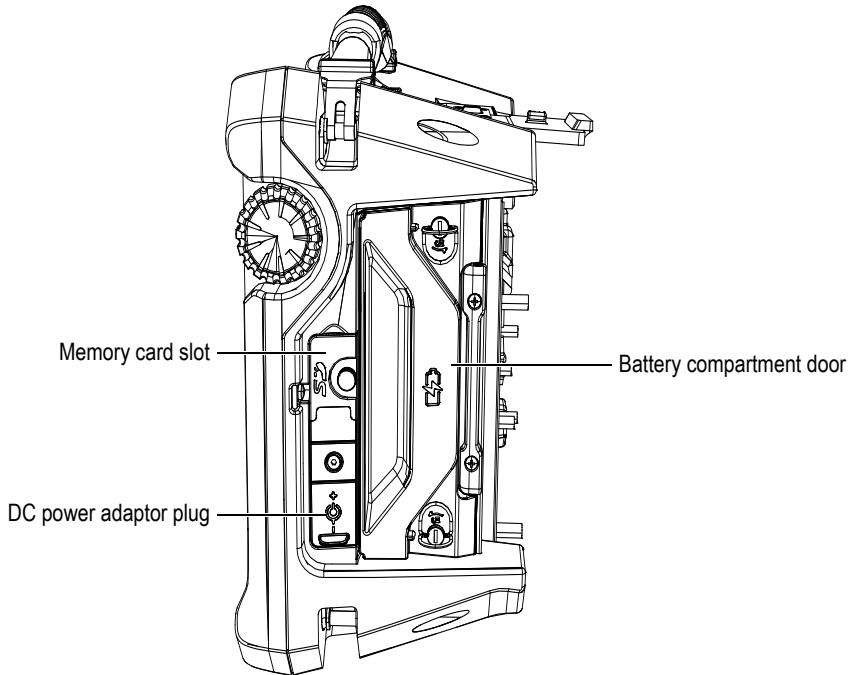

**Figure 1-2 Right side panel of the OmniScan MX2**

### Memory card slot

Slot for inserting the Secure Digital High Capacity (SDHC) memory card. (Lexar brand memory cards are recommended for optimal results.)

### DC power adaptor plug

Used to connect an external DC power adaptor to the OmniScan MX2.

### Battery compartment door

This door provides access to the battery compartment. Battery replacement is covered in "Battery Removal and Installation" on page 45.

## 1.3 Left Side Panel

The left side panel of the OmniScan MX2 (Figure 1-3 on page 35) contains standard computer interface ports used for expanded connectivity.

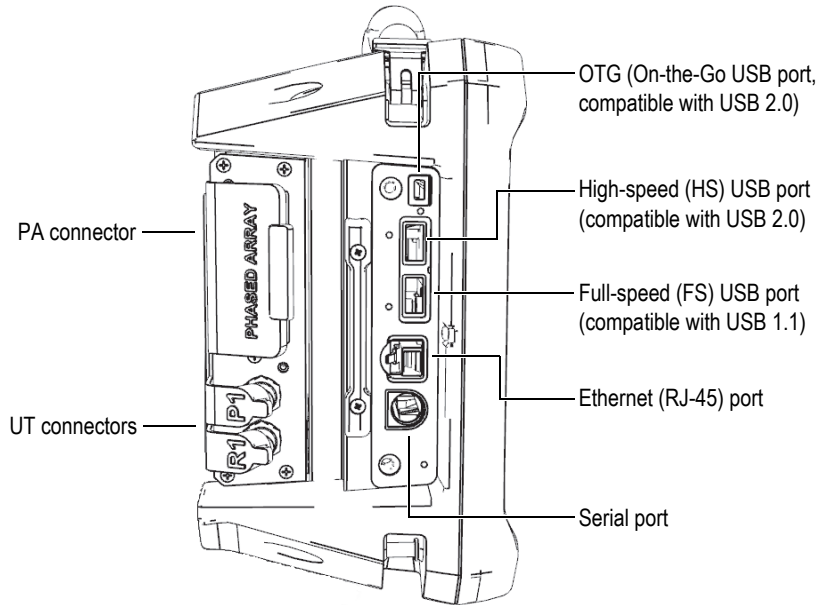

**Figure 1-3 Left side panel of the OmniScan MX2**

### USB ports (3)

The USB ports (Figure 1-3 on page 35) accommodate USB peripherals such as external keyboards, mice, storage devices, or printers.

### Ethernet (RJ-45) port

Used to connect to an Ethernet network.

### Serial port

Used mainly for debugging, or to supply DC power to accessories.

## 1.4 Top Panel

There are three connectors located on the top panel of the OmniScan MX2 (Figure 1-4 on page 36).

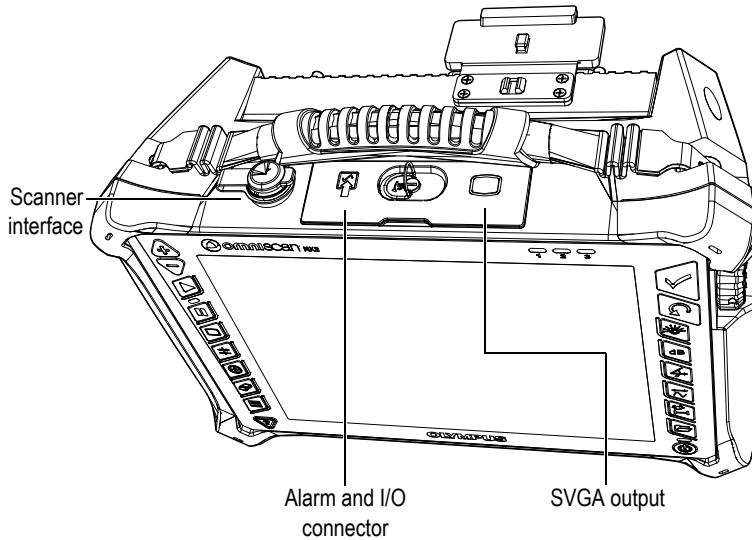

**Figure 1-4 Top panel of the OmniScan MX2**

### Scanner interface

Used to connect a scanner device equipped with an encoder.

### Alarm and I/O

Used as an alarm output and control input.

### SVGA output

An external VGA or SVGA monitor that mirrors the OmniScan MX2 display may be connected to this DB-15 port.

## 1.5 Rear Panel

The rear panel consists of the acquisition module currently connected to the OmniScan MX2. More information about each module's capabilities is available in the respective appendix.



### **CAUTION**

Using incompatible equipment can result in a malfunction and/or equipment damage.

---

For more information about installing or removing acquisition modules, refer to the appendices at the end of this manual.



---

## 2. Basic Operation

---

This chapter describes the basic principles and procedures involved in operating the OmniScan MX2 instrument.

### 2.1 Turning On and Off the OmniScan MX2

This section explains how to turn on and off the OmniScan MX2.

#### To turn on the OmniScan MX2



#### CAUTION

In order to prevent injury, do not place your fingers between the acquisition module and the instrument's support stand (when unfolded).

---

- ◆ Press the Power key () for one second.

The system starts up and performs a memory check. If there is more than one application installed on your instrument, each application will be displayed on one of the buttons appearing on the OmniScan MX2 touch screen. Choose the desired inspection application by tapping the appropriate menu on the touch screen.

**NOTE**

If the system encounters a problem during the start-up phase, the power indicator light will indicate the nature of the problem using a color code (for details, see “Power Indicator Light” on page 32).

---

**To turn off the OmniScan MX2**

1. Quickly press the Power key.

The “Select a command” message appears (Figure 2-1 on page 40).



**Figure 2-1 Shut Down button**

2. Select **Shut Down**.

A message asking you if you want to save your setup appears (Figure 2-2 on page 40).

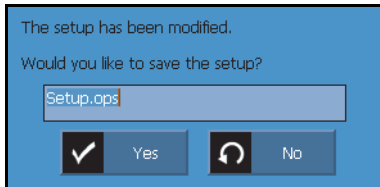

**Figure 2-2 Saving the setup**

3. To save your setup, select **Yes**.



**NOTE**



You can also turn off the OmniScan MX2 by pressing and holding the Power key for ten seconds. However, your setup will NOT be saved.

---

## 2.2 Automatic Start-Up Mode

The OmniScan MX2 has an automatic start-up mode: auto-boot. Use the auto-boot mode to remotely start the OmniScan MX2 instrument. When this mode is enabled, you do not need to press the Power key () to start the OmniScan MX2. The OmniScan MX2 starts up automatically when connected to a DC power adaptor. This mode is disabled by default.

### To activate the auto-boot

1. Turn off the OmniScan MX2 instrument, remove the batteries, and then disconnect the DC power adaptor.
2. Press and hold the Power key ()
3. Connect the OmniScan MX2 to a DC power adaptor.
4. Wait for the power indicator light to blink two times, and then release the Power key ()
5. To deactivate the auto-boot, repeat steps 1 to 4.

## 2.3 Power Supply Management

The OmniScan MX2 is a portable instrument that can draw power from either lithium-ion batteries or a DC power adaptor.

## 2.3.1 DC Power Adaptor

You can operate the OmniScan MX2 on AC power using the DC power adaptor (P/N: OMNI-A-AC [U8767093]). The OMNI-A-AC has a universal AC power input, which operates with any line voltage from 100 VAC to 120 VAC or from 200 VAC to 240 VAC, and at 50 Hz to 60 Hz line frequency.

### To use AC power

1. Connect the AC power cord to the DC power adaptor (P/N: OMNI-A-AC [U8767093]) and to an appropriate power outlet.



### CAUTION

Use only the AC power cord supplied with the OmniScan MX2. Do not use this AC power cord with other products.

---

2. On the right-hand side of the OmniScan MX2, lift the rubber seal covering the DC adaptor connector plug (Figure 2-3 on page 42).

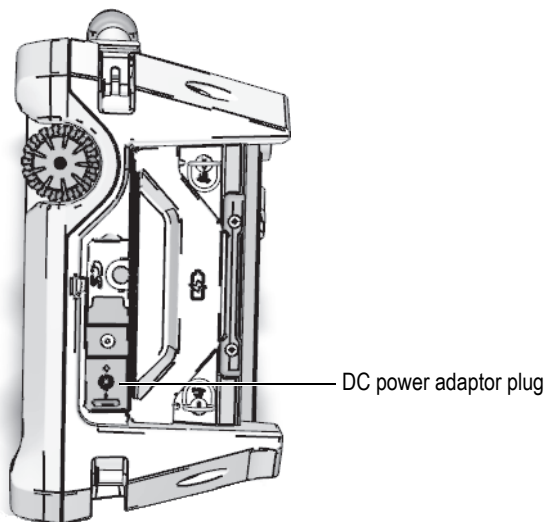

Figure 2-3 OmniScan MX2 DC power adaptor plug

3. Connect the DC power adaptor to the OmniScan MX2 DC power adaptor plug (Figure 2-3 on page 42).
4. Press the power key to start the OmniScan MX2.

### **2.3.2 Lithium-Ion Batteries**

The OmniScan MX2 holds up to two lithium-ion batteries, but will operate even with only one battery installed. When two batteries are installed, the OmniScan MX2 operates by default using the battery with the highest charge. When both batteries are at the same charge level, the OmniScan MX2 operates using both batteries at the same time. This increases battery life by about 10 % compared to using each battery individually.

Lithium-ion batteries can be inserted and removed without needing to shut down the OmniScan MX2, provided that there is another valid power source available (DC power adaptor or second battery).

The OmniScan MX2 also includes a lithium coin battery that does not need to be removed or replaced by the user. The coin battery keeps the instrument clock and masterboard configuration running.

### **2.3.3 Battery Status Indicators**

The battery status indicators located on the upper left corner of the display screen use one of the following two methods to indicate the amount of power remaining in each battery (Figure 2-4 on page 44):

- The remaining operation time is displayed on the battery status indicator. The OmniScan MX2 must be operated for approximately 15 minutes before it is able to accurately display this information.
- The charge indicator (bar) on the battery status indicator shows the approximate amount of remaining power in the battery.

If you attempt to start the OmniScan MX2 using batteries with an insufficient charge, the power indicator light will flash red for approximately three seconds. To operate the OmniScan MX2, replace the batteries or plug in the DC power adaptor.



**Figure 2-4 Battery charge status: Charge remaining in both batteries**

The battery currently in use is highlighted. When two batteries are used simultaneously, both are highlighted.

### **One-Battery Operation**

When there is only one battery inside the instrument, the charge indicator inside the battery status indicator displays the amount of power left in that battery.

### **Two-Battery Operation**







- When both batteries are used by the instrument simultaneously, the battery A indicator displays the total remaining operating time. Each battery status indicator indicates the discharge status.
- When one of the batteries has a higher charge level (voltage) than the other, the battery A indicator displays the total remaining operating time. However, only the battery with a higher voltage discharges, as shown by the status indicator.
- When both batteries are at the same charge level, they are both discharged at the same time. Discharging both batteries at the same time decreases resistance, which slightly increases the remaining operating time (by about 10 %).
- When a battery is removed, the remaining operating time is divided by two, minus approximately 10 %.
- The power reading remains displayed.

### **Battery Discharge**

Each battery status indicator displays the amount of time needed to discharge the corresponding battery.

The OmniScan MX2 software informs the user of the remaining power status. The battery status indicator variations are described in Table 4 on page 45.

**Table 4 Battery status indicator variations**

Indicator	Outline	Fill	Meaning
	Dotted	N/A	There is no battery in that compartment.
	Blue	Blue	The battery is functioning properly.
	Blue	Orange	The battery is too hot for use.
	Yellow (blinking)	Blue	The battery is charging.
	Orange	Blue	The battery is too hot to be charged, or the internal system temperature is too high to enable charging (over 60 °C [140 °F]).
	Red (blinking)	Blue	The battery charge is critically low (less than 10 %). A beeping noise is emitted when there is no spare battery available.
	N/A	Yellow	The OmniScan MX2 is being powered externally through the DC adaptor.

### 2.3.4 Battery Removal and Installation

#### To remove or install a battery

1. On the right side panel, turn the two quarter-turn latches to open the battery compartment door.
2. Pull the cloth tab to remove the battery (Figure 2-5 on page 46).

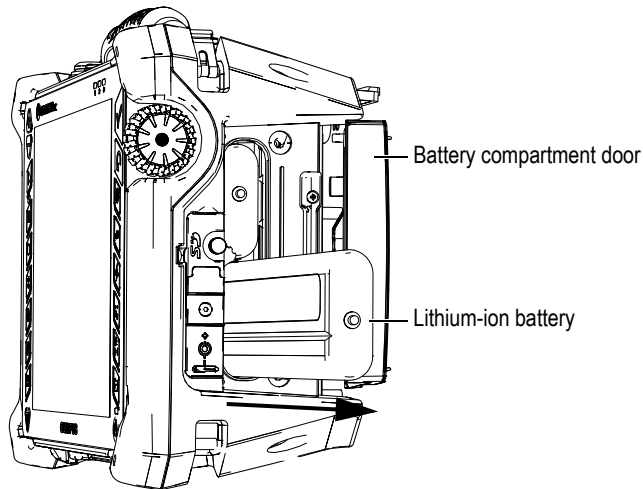

**Figure 2-5 Removing a lithium-ion battery**

3. Insert a new battery. Make sure that the groove on the battery is aligned with the small edge inside the battery compartment.
4. Close the battery compartment door.

The batteries are recharged inside the OmniScan MX2 when it is connected to a DC power adaptor. Connecting an adaptor automatically starts the recharging process. The batteries can also be recharged using an optional external charger.

## **2.3.5 Battery Charging**

### **To charge the OmniScan MX2 batteries**

- ◆ Connect the OmniScan MX2 to a proper DC power adaptor.

Battery charging is performed as follows:

- When the OmniScan MX2 is turned off:

When the OmniScan MX2 is connected to a proper DC power source and is turned off, it will automatically recharge any battery requiring charging, starting with the weakest battery (if the recharge conditions are met).

Once the weakest battery has reached the level of the other battery, both batteries are charged simultaneously.

The power indicator light indicates that batteries are currently being recharged when it flashes orange. When the charge is complete, the power indicator light emits a steady orange light. Each battery can take up to 3.5 hours to fully charge from a completely discharged state (less than 5 % remaining charge).

- When the OmniScan MX2 is running:

When the OmniScan MX2 is running and connected to a proper DC power source, it will automatically recharge any battery requiring charging, starting with the weakest battery (if the recharge conditions are met). The indicator for the battery being recharged flashes yellow.

Once the weakest battery has reached the same level as the other battery, both batteries are charged simultaneously.

Because the OmniScan MX2 is running, less power is available from the DC source to recharge the battery or batteries. As such, it could take up to 8 hours to charge each completely discharged battery. For more information about battery charge status, see Table 4 on page 45.

## 2.3.6 Maximizing the Performance of Lithium-Ion Batteries

This section describes lithium-ion battery care and maintenance.

### Storage instructions for rechargeable batteries

1. Before recharging, drain the batteries by running the OmniScan MX2 on battery power until it shuts down, or until you get a low-battery warning. Do not leave the battery dormant for long periods of time. Evident recommends using the battery at least once every two to three weeks. If a battery has not been used for a long period of time, perform the “New battery procedure” on page 48.

If you do not plan to use the OmniScan MX2 on battery power within three or more weeks, charge the batteries to between 40 % and 80 % capacity (three or four bars on the battery charge indicator), and then remove and store the batteries in a clean, cool, and dry place.

---

<b>NOTE</b>
-------------

Even when the OmniScan MX2 is turned off and unplugged, it draws a small amount of power from the battery, which could completely discharge the batteries in about 15 days.

---

2. Because lithium-ion batteries self-discharge over time, remember to check the remaining charge of any stored batteries approximately once a month to ensure that they have 40 % to 80 % remaining capacity, and recharge any that do not. Failure to do so may render a battery permanently unusable if it falls below a critical level (less than 1 %).
3. After an extended period of storage, the batteries should be recharged before use.

### **New battery procedure**

1. Anytime you acquire a new rechargeable battery, use it four to eight times consecutively in the OmniScan MX2, and ensure that you completely discharge and recharge it after each use. Doing so will enable it to reach maximum capacity, providing maximum run time.
2. It is good practice to completely discharge and recharge the battery after the first 10 to 15 periods of normal use (or after two to three weeks) in order to drain the battery, thus maintaining good run time and maximizing battery life.
3. Frequently switching from external DC power to battery power and vice versa may result in shorter battery life, because the charge/discharge cycles are limited (approximately 300 cycles). Please note that even a partial discharge and recharge of the battery accounts for one cycle.
4. To maximize battery life, before charging, always run the OmniScan MX2 on battery power until it shuts down, or until you get a low-battery warning. Recharge the battery with the OmniScan MX2 in turned-off mode for a shorter recharge time, or with the external charger if provided.

### **2.3.7 Used Battery Disposal**

Although lithium-ion batteries do not contain any environmentally hazardous components such as lead or cadmium, the batteries should be disposed of in accordance with local regulations. Batteries should be disposed of in a discharged state to avoid heat generation, and if applicable, in accordance with the European Directive on Waste Electrical and Electronic Equipment (WEEE). Refer to your local Evident distributor for return and/or collection systems available in your country.

### **2.3.8 Warnings on Battery Use**

Carefully read and observe the following warnings on battery use.



**WARNING**

- Do not open, crush, or perforate batteries; doing so could cause injury.
  - Do not incinerate batteries. Keep batteries away from fire and other sources of extreme heat. Exposing batteries to extreme heat (over 80 °C [176 °F]) could result in an explosion or personal injury.
  - Do not drop, hit, or otherwise abuse a battery, as doing so could expose the cell contents, which are corrosive and explosive.
  - Do not short-circuit the battery terminals. A short circuit could cause injury and severe damage to a battery, making it unusable.
  - Do not expose a battery to moisture or rain; doing so could cause an electric shock.
  - Only use the OmniScan MX2 or an external charger approved by Evident to charge the batteries.
  - Do not recharge a battery unless the indicators light up when the capacity check button on the battery is pressed. Doing so could be dangerous.
  - Do not store batteries that have less than 40 % remaining charge. Recharge batteries from 40 % to 80 % capacity before storing them.
  - During storage, keep the battery charged to between 40 % and 80 %.
  - Do not leave batteries in the OmniScan MX2 during instrument storage.
- 

## 2.4 Peripheral Connection

This section explains the peripherals that can be used with the OmniScan MX2.

---

**IMPORTANT**

The OmniScan MX2 has been tested and found to comply with the radio-frequency limits applicable to industrial devices, in accordance with the requirements of the EMC directive. To maintain OmniScan MX2 compliance with the emissions requirements of the EMC directive, the following conditions must be met:

- All cables used to connect the equipment must have an overall shielding to ensure electromagnetic compatibility and optimal performance.
-

- Ferrite clamp filters must be attached to the cables connected to the OmniScan MX2. For details, see “Ferrite clamp filters” on page 50.
- 

## Ferrite clamp filters

Before using the OmniScan MX2, attach the ferrite clamp filters (supplied with the OmniScan MX2) to the peripheral cables that will be connected to the OmniScan MX2 instrument and its modules. The optional peripherals are as follows:

- Evident UT probes
- Evident PA probe
- USB devices connected with a USB cable (printers, etc.)
- Ethernet network
- Scanner interface
- Alarm and I/O

If the ferrite clamp filters are not attached, the OmniScan MX2 instrument may fail to comply with the international and European electromagnetic emission specifications.

## To attach the clamp filters

---

<b>IMPORTANT</b>
------------------

- Make sure that the cable is not clamped in between the pawls of the ferrite clamp filter.
  - Attach the ferrite clamp filters as closely as possible to the cable ends. The ferrite clamp filters are not effective unless they are immediately adjacent to the cable end connected to the OmniScan MX2.
  - Use the ferrite clamp filter with the corresponding cable diameter. The filter must not slip easily or be difficult to clip onto the cable.
  - Make sure that the two ferrite clamp-filter parts are closed tight until the clamp clicks.
- 

1. Attach the ferrite clamp filter on the cable of the Evident UT probes, in close proximity to the connector for the OmniScan MX2.
  2. Attach the ferrite clamp filter on the cable of the Evident PA probe, in close proximity to the connector for the OmniScan MX2.
-

3. Attach the ferrite clamp filter to the USB cable, in close proximity to the connector for the OmniScan MX2.
4. Attach the ferrite clamp filter to the Ethernet cable, in close proximity to the connector (RJ-45) that connects to the OmniScan MX2.
5. Attach the ferrite clamp filter to the scanner interface cable, in close proximity to the connector (LEMO) for the OmniScan MX2.
6. Attach the ferrite clamp filter to the alarm and I/O cable, in close proximity to the connector (DE-9) for the OmniScan MX2.

Figure 2-6 on page 51 and Figure 2-7 on page 52 show the applicable connection for various cables on the OmniScan MX2, and the locations where the ferrite clamp filters must be attached.

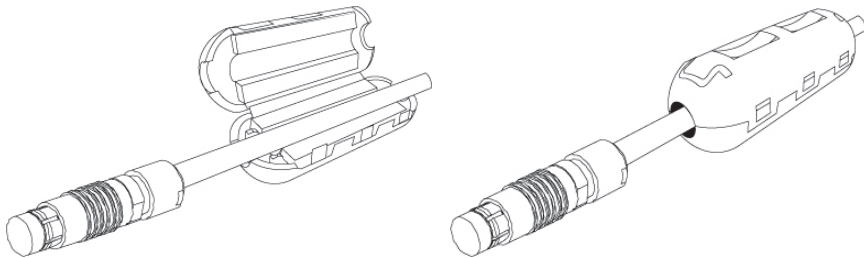

**Figure 2-6 Attaching a ferrite clamp filter to a cable (example shown with the scanner interface cable)**

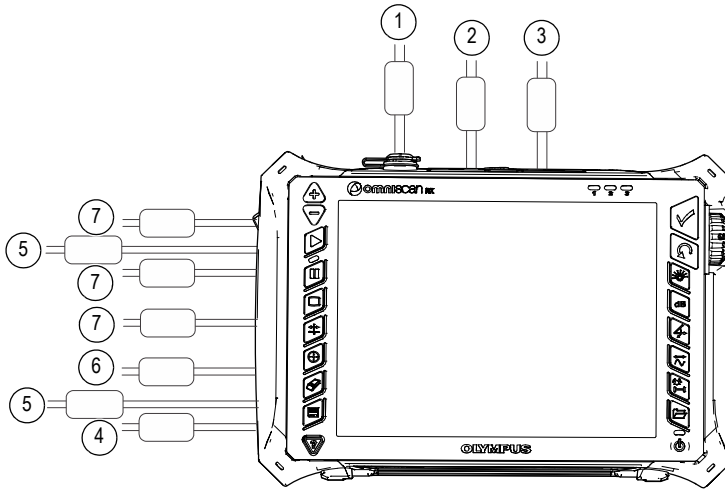

**Figure 2-7 OmniScan MX2 connection diagram — ferrite clamp filters**

**Table 5 Ferrite clamp filter locations**

ID	Description
1	Scanner connection
2	Alarm and I/O connector
3	SVGA output
4	Serial port
5	Probe connection (depending on the module)
6	LAN connection
7	USB device connections

## 2.5 OmniScan MX2 Software Installation

The OmniScan MX2 software installation is designed to be as trouble-free as possible. The software is stored on an SDHC card.

During upgrades to new versions, a message appears on the screen to inform you that the upgrade is taking place. However, no action is required on your part.

Refer to the Evident website for software updates and all related, applicable procedures.



---

## 3. Maintenance

---

This chapter describes the basic maintenance that must be performed on the OmniScan MX2 instrument by operators. The maintenance operations explained below enable you to keep your instrument in good physical and working condition. By virtue of its design, the OmniScan MX2 only requires minimal maintenance. The chapter covers preventative maintenance and instrument cleaning.

### 3.1 Preventative Maintenance

The OmniScan MX2 does not have many moving parts, and therefore only requires minimal preventative maintenance. Simply perform regular inspections to keep the OmniScan MX2 in proper working order.

### 3.2 Instrument Cleaning

The OmniScan MX2 external surfaces (which includes the casing, the acquisition module, and the touch-screen protector) may be cleaned as needed. This section provides the appropriate procedure for cleaning the instrument.

#### 3.2.1 Casing and Acquisition Module Cleaning

**To clean the casing and acquisition module (all modules except OMNI-M2-PA1664, OMNI-M2-PA16128, OMNI-M2-PA32128 and OMNI-M2-PA32128PR)**

1. Make sure that the instrument is turned off, and that the power cord is disconnected.
2. Disconnect all cables and connectors, and make sure that all external ports on the OmniScan MX2 have been covered with their rubber protectors.

3. Make sure that the access doors are closed.
4. Place the cap on the scanner interface connector.
5. Make sure that the battery compartment door is closed correctly, and that an acquisition module has been installed on the OmniScan MX2.



### CAUTION

Because the acquisition modules are not IP rated, you must install the module and instrument rubber protectors before cleaning the casing or acquisition module. Otherwise, liquid could seep into cracks or flow into the housing and damage circuits.

---

### IMPORTANT

Installing rubber protectors on the acquisition module will not render it IP compliant.

---

6. Make sure the left side panel is closed.
7. To restore the instrument's original finish, clean the casing and module with a soft cloth.
8. To remove persistent stains, use a damp cloth with a mild, soapy solution. Do not use abrasive products or powerful solvents, which could damage the finish.
9. Once the connector protectors are removed, make sure the connectors are dry before connecting anything to them. If they are wet, dry them with a soft, dry cloth, or let them air dry.

### **To clean the casing and acquisition module (OMNI-M2-PA1664, OMNI-M2-PA16128, OMNI-M2-PA32128 and OMNI-M2-PA32128PR modules only)**

1. Make sure that the instrument is turned off, and that the power cord is disconnected.
2. Install a PA connector cap on the PA connector (Figure 3-1 on page 57).  
OR  
Connect a EZ Latch probe to the PA connector.



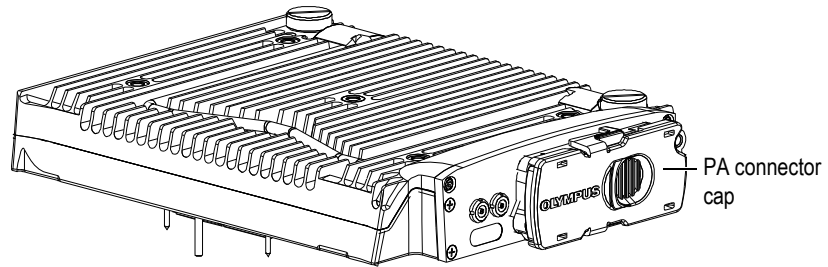

**Figure 3-1 Module with PA connector cap**

3. Make sure that all external ports on the OmniScan MX2 have been covered with their rubber protectors.
4. Make sure that the access doors are closed.
5. Place the cap on the scanner interface connector.
6. Make sure that the battery compartment door is closed correctly.
7. Make sure the left side panel is closed.
8. To restore the instrument's original finish, clean the casing and module with a soft cloth.
9. To remove persistent stains, use a damp cloth with a mild, soapy solution. Do not use abrasive products or powerful solvents, which could damage the finish.
10. Once the connector protectors are removed, make sure the connectors are dry before connecting anything to them. If they are wet, dry them with a soft, dry cloth, or let them air dry.

### **3.2.2 Screen and Screen Protector Cleaning**

Never use abrasive products or powerful solvents to clean the OmniScan MX2 touch screen and screen protector. Clean the touch screen and screen protector using a damp cloth moistened with a standard, evaporating glass cleaner. If necessary, remove any paper-towel residue with a soft-bristle brush.



### CAUTION

Never spray liquid directly onto the acquisition modules. Liquid could seep into the cracks or flow into the housing and damage circuits. Before cleaning the screen, make sure that the rubber protectors are installed on the acquisition module.

---

## 3.3 Replacing the Touch-Screen Protector

This section explains how to replace the touch-screen protector.

### To replace the touch-screen protector

1. Remove any dust or dirt on the touch screen (dust and dirt cause bubbles to appear on the protective film). See “Screen and Screen Protector Cleaning” on page 57.
2. Simply remove the label marked No. 1, and peel away the protective film on the back.

---

#### NOTE

Avoid touching the back of the screen protector after the protective film on the back is peeled away. Doing so will leave a trace of your finger prints.

---

3. Align the protector into the correct position on the screen, and slowly install the screen protector.
4. Remove the label marked No. 2, and peel away the film on the front. Provided that there is no dust trapped underneath, all small bubbles will dissipate within 48 hours.

---

#### TIP

Dust particles can be blown away prior to installation using a can of compressed air.

---

---

## 4. Troubleshooting

---

This chapter will help you resolve minor problems that could occur during operation of your OmniScan MX2 instrument. This troubleshooting guide has been prepared based on the assumption that the instrument has not been modified, and that all cables and connectors used are those provided and documented by Evident.

### 4.1 Start-Up Problems

The OmniScan MX2 does not start.

#### Possible solutions

- Check that the DC power adaptor is connected to both the OmniScan MX2 and a power outlet with the proper voltage. Use only the adaptor supplied with the OmniScan MX2.
- Make sure that there is at least one battery charged to at least 10 % capacity and correctly inserted into the battery compartment.
- Press and hold the Power key () for three seconds or longer.

### 4.2 Message

A message appears during the start-up sequence (Table 6 on page 60).

**Table 6 Message**

<b>Message</b>	<b>Solution</b>
<b>No module detected</b>	Make sure that you have an acquisition module correctly attached to the base unit.

### 4.3 Battery Charging Problems

The batteries do not charge when placed in the OmniScan MX2.

#### Possible solutions

- Make sure that the battery model used in the OmniScan MX2 is compatible with the model suggested by Evident. An incompatible battery may be able to power the instrument, but the recharge protocol may not recognize it.
- Make sure that the DC power adaptor is connected correctly.
- Charge the batteries using an external charger. The batteries charge much quicker when the OmniScan MX2 is not in use. However, the batteries will charge very slowly, if at all, if the power consumption is too high.
- Shut down the OmniScan MX2 and wait for it to cool. Battery charging is disabled when the battery temperature or the system's internal temperature is too high. This status will be indicated on the battery status indicator (Table 4 on page 45 for battery status indicator descriptions).

### 4.4 Battery Life Problems

The battery charge does not last as long as it used to.

#### Possible solutions

- Drain the batteries completely before recharging them to extend their life.
- Recondition the batteries once a month using an external battery charger. Although the lithium-ion batteries do not suffer from the "memory effect" commonly affecting other battery types, they should be reconditioned for optimum efficiency (for details, see "Maximizing the Performance of Lithium-Ion Batteries" on page 47).

- Verify your current configuration. There may be an option or combination of options that are causing the batteries to drain too quickly. Such options could include the brightness, voltage level, and acquisition rate.



## 5. Specifications

This chapter covers the OmniScan MX2 instrument specifications. It includes the general specifications for the instrument, in addition to the specifications applicable to alarms and safety (Table 7 on page 63 and Table 8 on page 66).

### NOTE

For the specifications applicable to specific acquisition modules, please refer to the respective appendices at the end of this manual.

**Table 7 OmniScan MX2 general specifications**

<b>Housing</b>	
Size	325 mm × 235 mm × 130 mm (12.8 in. × 9.3 in. × 5.1 in.)
Weight	3.2 kg (7 lb) [no module and one battery] 5 kg (11 lb) [with module and one battery]
<b>Environmental conditions</b>	
Operating temperature	0 °C to 45 °C [32 °F to 113 °F] -10 °C to 45 °C [14 °F to 113 °F] (with OMNI-M2 modules)
Storage temperature	-20 °C to 60 °C [-4 °F to 140 °F] (with batteries inside) -20 °C to 70 °C [-4 °F to 158 °F] (with no batteries inside)
Relative humidity (RH)	Max. 70 % RH at 45 °C [113 °F] noncondensing
Altitude	Up to 2000 m

**Table 7 OmniScan MX2 general specifications (continued)**

Outdoor use	To be used with batteries only
IP rating	Designed to meet requirements of IP66 when used with OMNI-M2 modules
Pollution level	2
<b>Batteries</b>	
Battery model	OMNI-A-BATT (U8760010)
Battery type	Smart lithium-ion batteries
Number of batteries	1 or 2
Battery storage temperature	-20 °C to 60 °C [-4 °F to 140 °F] ≤ 1 month -20 °C to 45 °C [-4 °F to 113 °F] ≤ 3 months
Battery charge time	<3.5 hours using the internal charger or an optional battery charger
Battery life	<ul style="list-style-type: none"> <li>• Minimum 6 hours with two batteries under normal operating conditions</li> <li>• OMNI-M2 modules: minimum 7 hours with two batteries under normal operating conditions</li> </ul>
Size	119 mm × 60 mm × 32 mm, ±1 mm (4.69 in. × 2.36 in. × 1.26 in., ±0.04 in.)
<b>External DC supply</b>	
DC-IN voltage	15 VDC to 18 VDC (min. 50 W)
Connector	Circular, 2.5 mm pin diameter, center-positive
Suggested model	OMNI-A-AC (U8767093)
<b>Display</b>	
Display size (diagonal)	264 mm (10.4 in.)
Resolution	800 × 600 pixels
Number of colors	16 million
Type	TFT LCD
Viewing angles	Horizontal: -80° to 80° Vertical: -60° to 80°



**Table 7 OmniScan MX2 general specifications (continued)**

<b>Data storage</b>	
Storage devices	SDHC card, most standard USB storage devices, or through optional Fast Ethernet
Maximum data file size	300 MB
<b>I/O ports</b>	
USB ports	2 USB ports compliant with USB 2.0 specifications: OTG <sup>a</sup> (On-the-Go) USB, USB High Speed (HS)
	1 USB port compliant with USB 1.1 specifications: USB full-speed (FS)
	USB HS and OTG USB (host mode) can operate at high speed, full speed, and low speed
	USB FS can operate at full speed and low speed
	Theoretical speed: HS: 480 Mbps (megabits per second) FS: 12 Mbps LS: 1.5 Mbps
Video output	Video out (SVGA)
Ethernet	10/100 Mbps
<b>I/O lines</b>	
Encoder	2-axis encoder line (quadrature or clock/direction)
Digital input	4 digital inputs TTL, 5 V
Digital output	4 digital outputs TTL, 5 V, 15 mA maximum per output
Remote communication	Remote communication RS-232: 2 serial ports using 3-wire RS-232
Acquisition on/off switch	Remote acquisition enable TTL, 5 V
Power output line	5 V nominal, 500 mA maximum, shared between both Serial Out connector and Scanner connector power output (short-circuit protected)

**Table 7 OmniScan MX2 general specifications (continued)**

Alarms	3 TTL, 5 V, 15 mA maximum
Analog output	2 analog outputs (12-bit resolution) $\pm 5$ V nominal in 10 k $\Omega$ , , maximum 10 mA per output
Pace input	5 V, TTL pace input

- a. At this time, OTG is available in host mode only.

**Table 8 OmniScan MX2 alarms**

Alarms	
Number of alarm zones	3
Conditions	Any logical combination of gates
Analog outputs	2



## 6. Connector References



### WARNING

Always use equipment and accessories that meet Evident specifications. Using incompatible equipment can result in a malfunction, equipment damage, or injury.

This chapter provides a technical description of the OmniScan MX2 instrument connectors and adaptor below:

- “Serial Connector” on page 68 ()
- “Scanner Interface Connector” on page 69
- “Alarm and I/O Connector” on page 72 ()

The following information is provided for each of these connectors: a brief description, the manufacturer’s number, the number of the corresponding cable connector, an illustration, and a table with the signal pinout for the connector.

The following OmniScan MX2 connectors comply with their respective standards:

- SDHC (memory card slot)
- Circular DC power jack, 2.5 mm pin diameter, 15 VDC to 18 VDC (polarity: )
- USB
- Fast Ethernet (RJ-45)
- VGA

## 6.1 Serial Connector

### Description

Mini-DIN, female connector

### Manufacturer, number

Kycon, KMDG-8S-BS

### Suggested cable connector

Kycon, KMDLA-8P

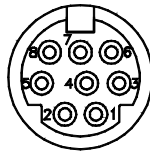

Figure 6-1 Serial connector

Table 9 Pinout for the serial connector

Pin	I/O	Signal	Description	Level
1	In	Video in	Video input	1 V <sub>p-p</sub>
2	–	+5 V	500 mA max. Note: This power is shared with pin 2 of the scanner interface connector (see “Scanner Interface Connector” on page 69).	N/A
3	–	SOUT2	Serial out	RS-232
4	–	GND	Ground	N/A
5	–	SIN2	Serial in	RS-232
6	–	NC	No connection	N/A

**Table 9 Pinout for the serial connector (continued)**

Pin	I/O	Signal	Description	Level
7	–	+10 V to 12.6 V	500 mA max., short- circuit protected	N/A
8	–	NC	No connection	N/A

## 6.2 Scanner Interface Connector

### Description

LEMO, 16-pin female circular connector

### Manufacturer, number

LEMO, EEG.1K.316.CLL

### Suggested cable connector

LEMO, FGG.1K.316.CLAC65Z

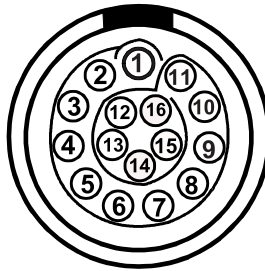

**Figure 6-2 Scanner interface LEMO connector (contact view)**

**Table 10 Pinout for the scanner interface LEMO connector**

Pin	I/O	Signal	Description	Current	Level
1	In	AIN	Analog input	$\pm 2.5$ mA (2 k $\Omega$ input impedance)	$\pm 5$ V
2	Out	+5 V	External power supply This power is shared with pin 2 of the serial connector (see “Serial Connector” on page 68).	500 mA	N/A
3	In	DIN1	Digital input 1. Programmable input. Can be configured for different functionalities. By default, this input is disabled. Refer to the <i>OmniScan MXU Software User’s Manual</i> (“Configuring the Digital Input”) for information on programming this input. To activate the input, you must use a high-level signal with a minimum signal length of 50 ms.	N/A	TTL
4	In	DIN2	Digital input 2. Programmable input. Can be configured for different functionalities. By default, this input is disabled. Refer to the <i>OmniScan MXU Software User’s Manual</i> (“Configuring the Digital Input”) for information on programming this input. To activate the input, you must use a high-level signal with a minimum signal length of 50 ms.	N/A	TTL

**Table 10 Pinout for the scanner interface LEMO connector (continued)**

Pin	I/O	Signal	Description	Current	Level
5	In	DIN3	Digital input 3. Programmable input. Can be configured for different functionalities. By default, this input is disabled. Refer to the <i>OmniScan MXU Software User's Manual</i> ("Configuring the Digital Input") for information on programming this input. To activate the input, you must use a high-level signal with a minimum signal length of 50 ms.	N/A	TTL
6	In	DIN4	Digital input 4. Programmable input. Can be configured for different functionalities. By default, this input is disabled. Refer to the <i>OmniScan MXU Software User's Manual</i> ("Configuring the Digital Input") for information on programming this input. To activate the input, you must use a high-level signal with a minimum signal length of 50 ms.	N/A	TTL
7	Out	DOUT1/ PaceOut	Digital out 1/pace output	±15 mA	TTL
8	Out	DOUT2	Digital output 2	±15 mA	TTL
9	In	PhA axis 1	Encoder 1: phase A/clock/up/ down	N/A	TTL
10	In	PhB axis 1	Encoder 1: phase B/direction/ N.U./N.U. <sup>a</sup>	N/A	TTL
11	In	PhB axis 2	Encoder 2: phase B/direction/ N.U./N.U.	N/A	TTL

**Table 10 Pinout for the scanner interface LEMO connector (continued)**

Pin	I/O	Signal	Description	Current	Level
12	In	PhA axis 2	Encoder 2: phase A/clock/up/ down	N/A	TTL
13	Out	DOUT3	Digital output 3	±25 mA	TTL
14	In	RRX	RX	N/A	RS-232
15	Out	RTX	TX	N/A	RS-232
16	–	GND	Ground	N/A	

a. N.U. = Not used

### 6.3 Alarm and I/O Connector

Description

DE-9, female connector

Manufacturer, number

Amphenol, 788797-1

Suggested cable connector

ITT Cannon, DE-9P

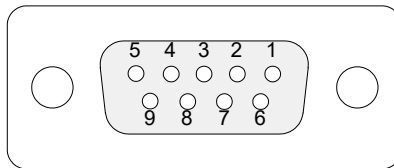

**Figure 6-3 Alarm and I/O connector**



Table 11 Pinout for the alarm and I/O connector

Pin	I/O	Signal	Description	Current	Level
1	Out	Al1	Alarm output 1. Disabled on reset, and is at 0 V. When active, it is at 5 V.	±15 mA	TTL
2	Out	Al2	Alarm output 2. Disabled on reset, and is at 0 V. When active, it is at 5 V.	±15 mA	TTL
3	Out	Al3	Alarm output 3. Disabled on reset, and is at 0 V. When active, it is at 5 V.	±15 mA	TTL
4	Out	AOUT1	Analog output 1	±10 mA	±5 V
5	Out	AOUT2	Analog output 2	±10 mA	±5 V
6	–	GND	Ground	N/A	N/A
7	Out	DOUT4	Digital output 4	±15 mA	TTL
8	Out	DOUT3	Digital output 3	±15 mA	TTL
9	In	DIN4/ ExtPace	Digital input 4/external pace input Programmable input. Can be configured as generic input 4, or as an external pace input (high level with a minimum signal length of 50 ms when used as DIN4, or 21 µs as ExtPace). Refer to the <i>OmniScan MXU Software User's Manual</i> (“Configuring the Digital Input”) for more information on programming this input.	N/A	TTL



# OmniScan MX and OmniScan MX1

Model no. OMNI-MX and OMNI-MX1



---

## Introduction

---

---

<b>IMPORTANT</b>
------------------

The OmniScan MX and OmniScan MX1 instrument models, for the purposes of the explanations in this manual, are most frequently referred to together as “OmniScan MX / MX1.” For details on the differences between these two models, see “Available and Discontinued Products” on page 77.

---

The OmniScan MX / MX1 by Evident is an innovative and portable multitechnology nondestructive testing (NDT) instrument. It is suitable for a number of applications, including tube inspection, weld inspection, and corrosion mapping.

The system supports any of the following NDT technologies: conventional ultrasonics (UT); phased array ultrasonics (PA); conventional eddy current testing (ECT); and eddy current array testing (ECA). Each of these technologies offers unique capabilities and a level of performance previously unseen in an instrument of this size.

The OmniScan MX / MX1 also doubles as an all-in-one instrument by virtue of its modular design. Various modules are available, each with a particular inspection technology.

## Available and Discontinued Products

Table 12 on page 78 lists the CE-compliant products—for eddy current array (ECA) and bond testing only—that are available at time of writing of this manual revision N (English), as well as the discontinued products.

**IMPORTANT**

The CE-compliant OmniScan MX1 model, module, and package are compatible only with ECA and bond testing applications. The OmniScan MX1 is not compatible with any phased array (PA) or ultrasonic (UT) applications. Any PA or UT features of the discontinued OmniScan MX model have been included in this manual revision N (English) only for current users of this instrument. At time of writing of this manual revision, Evident recommends the OmniScan MX2 instrument for any users who wish to purchase a new PA- or UT-capable instrument.

**IMPORTANT**

This unit has been licensed for Windows Compact 2013 and then downgraded back to Windows CE 5 for application compatibility.

**Table 12 Available OmniScan MX1 and discontinued OmniScan MX products**

Available OmniScan MX1 products (CE compliant, for ECA applications only)	Discontinued OmniScan MX products
OmniScan MX1 instrument P/N: OMNI-MX1 (Q1000033)	OmniScan MX instrument P/N: OMNI-MX (U8100026)
OmniScan MX1 – ECA module P/N: OMNI-M1-ECA4-32 (Q2700052)	OmniScan MX – ECA module P/N: OMNI-M-ECA4-32 (U8100014)
OmniScan MX1 – ECA package P/N: OMNI-P1-ECA4-32 (Q2700053)	OmniScan MX – ECA package P/N: OMNI-P-ECA4-32 (U8100027)

## OmniScan MX / MX1 Features

The OmniScan MX / MX1 offers the following features (ultrasound-related features are not included in the MX1 model):

- Data storage and imaging
- Conventional ultrasonic technology (UT)
- Phased array ultrasonic technology (PA)

- C-scan production
  - Real-time color display of the volume of a test part (sectorial scanning)
  - Up to 256 selectable A-scans per image
  - Conventional eddy current (ECT) and eddy current array (ECA) modules
- 

<b>NOTE</b>
-------------

The illustrations in this manual were prepared with the instrument version available at the time of publication; they may differ slightly from what you see on the OmniScan MX / MX1 according to the current instrument version you are using.

---





---

## 7. Overview of the Equipment

---

This chapter describes the physical characteristics of the OmniScan MX / MX1, which features a modular design. Each acquisition module is presented in its respective appendix at the end of this manual.

### 7.1 Front Panel of the OmniScan MX / MX1

The front panel of the OmniScan MX / MX1 (Figure 7-1 on page 82) contains all the main controls. This panel is divided into different areas, which are explained further in the following sections.

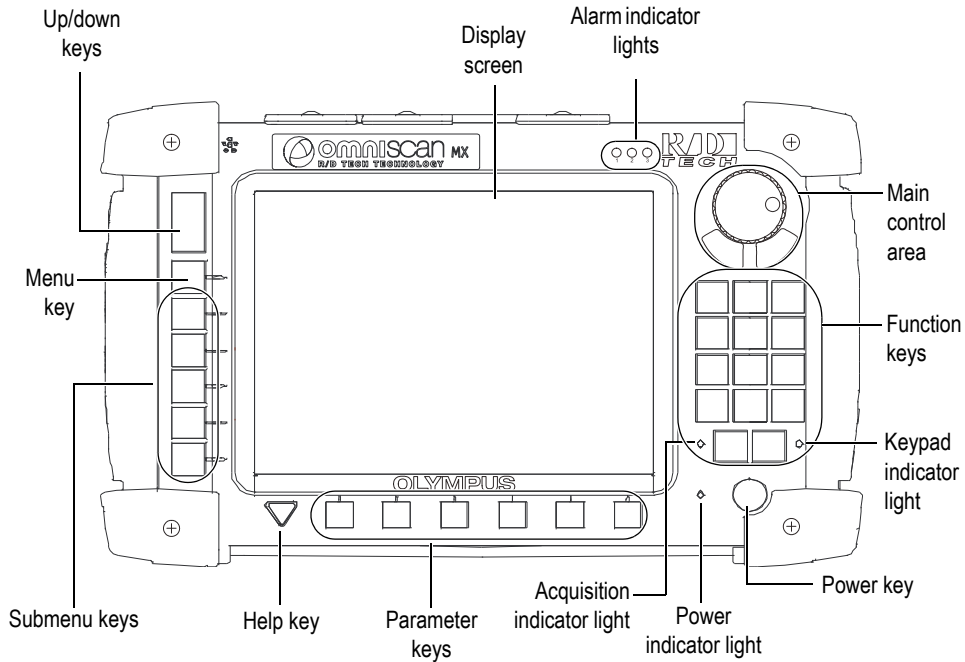



**Figure 7-1 Front panel of the OmniScan MX / MX1**

### 7.1.1 Main Control Area

The main control area is shown in Figure 7-1 on page 82. You can control the OmniScan MX / MX1 completely from this area if you wish. The main control area contains three elements, which are described in Table 13 on page 83.

**Table 13 Main control area**

Element	Name	Description
	Scroll knob	Used to navigate through selections without the need for a keyboard or mouse. Turning the scroll knob in a clockwise direction shifts a selection to the right (horizontal list), or upward (vertical list). For more information about using the scroll knob with the OmniScan software, refer to the Evident OmniScan software user's manuals.
	Cancel key	Used to cancel the current selection, or to go back one level in the menu hierarchy.
	Accept key	Used to confirm a selection.

### 7.1.2 Function Keys

There are 14 function keys on the front panel of the OmniScan MX / MX1. These keys include up to three types of information, with each type of information being color-coded as follows:

- White: a primary function when connected to either ECT or UT modules
- Yellow: alphabetical characters and symbols
- Green: numeric characters and signs

It is possible to use the function keys to enter alphabetical and numeric characters, symbols, and signs in an edit field.

To enter alphanumeric values in an edit field, the edit field must first be selected. This will cause the function keys to switch to alphanumeric mode, and the keypad indicator light to flash orange (see "Keypad Indicator Light" on page 86). You can then use the Start/Stop and Acquisition/Print keys to move the cursor forward and backward inside the edit field.

The function keys all have yellow and green printed characters (Figure 7-2 on page 84). The yellow characters represent alphabetical characters and symbols; the green characters represent numeric characters and signs. Pressing a function key will first cycle through the yellow characters, and next through the green characters, before returning back to yellow. To proceed to the next character, press another function key, or simply wait one second.

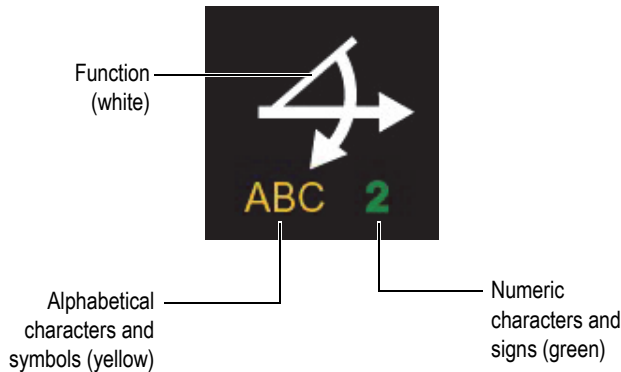

**Figure 7-2 Information provided on each key**

---

<b>NOTE</b>
-------------

Refer to the OmniScan software user’s manuals for more information on software functions.

---

### 7.1.3 Power Key

Power key (  )

Used to start or shut down the OmniScan MX / MX1.

## 7.1.4 Up and Down Keys

The Up and Down keys can be used to navigate the interface without having to use the scroll knob and Accept key in the main control area.

Up key ()

Used to move upward in a vertical list, or to the right in a horizontal list.

Down key ()

Used to move downward in a vertical list, or to the left in a horizontal list.

When these two keys are pressed simultaneously, they perform the same function as the Accept key in the main control area.



## 7.1.5 Menu Key

The blue Menu key is located on the upper left side of the OmniScan MX / MX1 front panel.

Menu key ()

Used to automatically display all available menus from almost any location within the software.

## 7.1.6 Submenu Keys

The submenu keys are labeled F2, F3, F4, F5, and F6 ( to ) , and are located on the left side of the OmniScan MX / MX1 front panel.

Each of these keys is used to select the submenu that appears next to it.



## 7.1.7 Help Key

The yellow Help key is shaped in the form of an inverted triangle, and located on the lower-left side of the OmniScan MX / MX1 front panel.

Help key (  )

Pressing this key displays the online help for the function currently selected.

## 7.1.8 Parameter Keys

The Parameter keys are labeled F7, F8, F9, F10, F11, and F12 (  to  ), and are located on the bottom of the OmniScan MX / MX1 front panel. These keys are used to select parameters for specific submenus.

Each of these keys is used to select the parameter displayed above it.

## 7.1.9 Indicator Lights

There are four types of indicator lights on the OmniScan MX / MX1 front panel: keypad, power, acquisition, and alarm. Each indicator light is described below.

### 7.1.9.1 Keypad Indicator Light

The keypad indicator light is located to the right of the Acquisition/Print key (  ). Its color identifies the status of the keypad (Table 14 on page 86).

**Table 14 Keypad indicator light statuses**

Off	Function mode
Green	Numeric keypad
Orange	Alphanumeric keypad
Red	Keypad locked

### 7.1.9.2 Power Indicator Light

The power indicator light is located to the left of the Power key (  ). Its color indicates the power status of the OmniScan MX / MX1 (Table 15 on page 87).

**Table 15 Power indicator light statuses**

Off	The OmniScan MX / MX1 is turned off.
Green	The instrument is ready (start-up complete).
Orange	Battery charging is complete.
Flashing orange/green	The OmniScan MX / MX1 is shut off. Battery A is charging.
Flashing orange/red	The OmniScan MX / MX1 is shut off. Battery B is charging.
Flashing red	Critical factor (temperature, very weak battery, etc.)

### 7.1.9.3 Acquisition Indicator Light

The acquisition indicator light is located to the left of the Start/Stop key (). The color of this light indicates the OmniScan MX / MX1 operating mode (Table 16 on page 87).

**Table 16 Acquisition indicator light statuses**

Off	Acquisition mode
Flashing orange	Paused analysis mode

#### **NOTE**

If an acquisition module is removed while the OmniScan MX / MX1 is turned on, the keypad, power, and acquisition indicator lights flash red for a few seconds, and then the unit automatically shuts down to prevent damage to the internal circuits.

#### 7.1.9.4 Alarm Indicator Lights

There are three alarm indicator lights (numbered 1, 2, and 3) located on the upper right corner of the OmniScan MX / MX1. These lights only flash one color (red) and indicate the trigger status of their respective alarms (set by the software).

---

<b>NOTE</b>
-------------

For more details about the alarm indicator lights, refer to the OmniScan software user's manuals.

---

## 7.2 Right Side Panel

The right side panel of the OmniScan MX / MX1 (Figure 7-3 on page 89) contains various input and output ports.



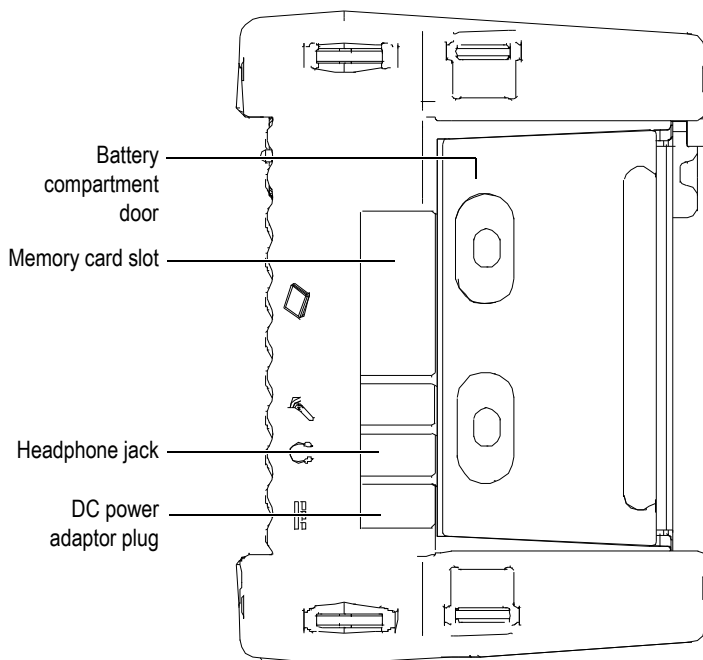

**Figure 7-3 Right side panel of the OmniScan MX / MX1**

#### DC power adaptor plug

Used to connect an external DC power adaptor to the OmniScan MX / MX1.

#### Headphone jack

Used to connect a set of headphones or external speakers to the OmniScan MX / MX1 for greater audio capacity than the internal speaker.

#### Memory card slot

Slot for inserting a CompactFlash memory card.

#### Battery compartment door

This door provides access to the battery compartment. Battery replacement is covered in "Battery Removal and Installation" on page 97.

## 7.3 Left Side Panel

The left side panel of the OmniScan MX / MX1 (Figure 7-4 on page 90) contains standard computer interface ports used for expanded connectivity.

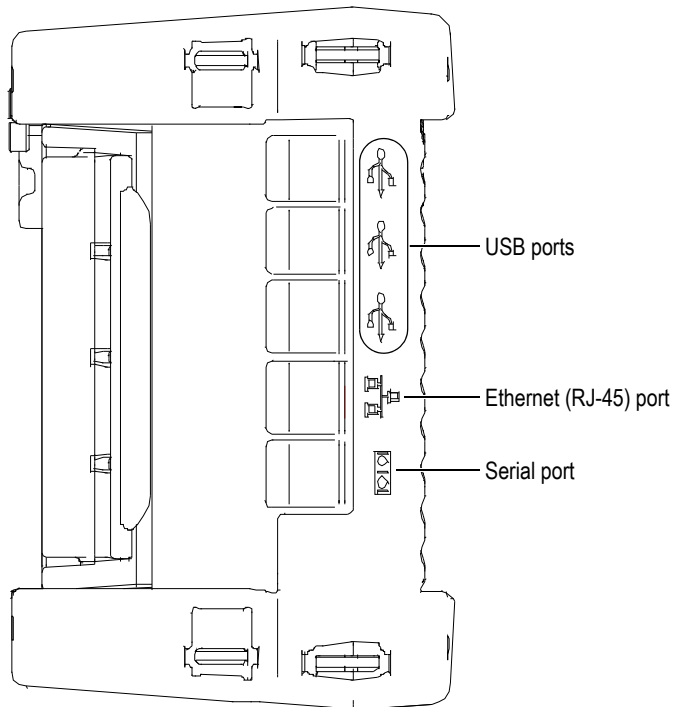

**Figure 7-4 Left side panel of the OmniScan MX / MX1**

### USB 1.1 ports (3)

Each one of the three USB 1.1 ports can accommodate USB peripherals such as external keyboards, mice, storage devices, printers.

### Ethernet (RJ-45) port

Used to connect to an Ethernet network.

### Serial port

Used mainly for debugging, or to supply DC power to accessories.

## 7.4 Top Panel

There are three connectors located on the top panel of the OmniScan MX / MX1 (Figure 7-5 on page 91).

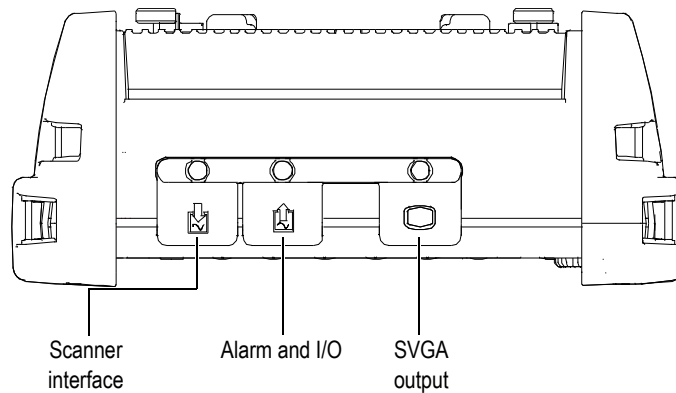

**Figure 7-5 Top panel of the OmniScan MX / MX1**

### Scanner interface

Used to connect a mechanical scanner.

### Alarm and I/O

Used as an alarm output and control input.

### SVGA output

An external VGA or SVGA monitor that mirrors the OmniScan MX / MX1 display may be connected to this DB-15 port.

## 7.5 Rear Panel

The rear panel consists of the acquisition module currently connected to the OmniScan MX / MX1. More information about each module's capabilities is available in the respective appendix.



**CAUTION**

Using incompatible equipment can result in a malfunction and/or equipment damage.

---

For more information about installing or removing acquisition modules, refer to the appendices at the end of this manual.

---

## 8. Basic Operation

---

This chapter describes the basic principles and procedures involved in operating the OmniScan MX / MX1.

### 8.1 Turning On and Off the OmniScan MX / MX1

To turn on the OmniScan MX / MX1



#### CAUTION

In order to prevent injury, do not place your fingers between the acquisition module and the instrument's support stand (when unfolded).

---

- ◆ Press and hold the Power key (  ) for one second.  
The system starts up, performs a memory check, and displays the OmniScan logo and software version number. If there is more than one application installed on your instrument, each application will be displayed on one of the buttons appearing on the OmniScan splash screen. Choose the desired inspection application by pressing the "F" (Parameter) key corresponding to the appropriate button.

---

<b>NOTE</b>
-------------

If the system encounters a problem during the start-up phase, the power indicator light will indicate the nature of the problem using a color code (for details, see “Power Indicator Light” on page 86).

---

### To turn off the OmniScan MX / MX1

- ◆ Press and hold the Power key () for three seconds.  
The power indicator light turns orange when the OmniScan MX / MX1 is shutting down.

## 8.2 Power Supply Management

The OmniScan MX / MX1 is a portable instrument that can draw power from either lithium-ion batteries or a DC power adaptor.

### 8.2.1 DC Power Adaptor

You can operate the OmniScan MX / MX1 with AC power using the DC power adaptor (P/N: OMNI-A-AC [U8767093]). The OMNI-A-AC has a universal AC power input, which operates with any line voltage from 100 VAC to 120 VAC or from 200 VAC to 240 VAC, and a 50 Hz to 60 Hz line frequency.

#### To use AC power

1. Connect the AC power cord to the DC power adaptor (P/N: OMNI-A-AC [U8767093]) and to an appropriate power outlet.



<b>CAUTION</b>
----------------

Use only the AC power cord supplied with the OmniScan MX / MX1. Do not use this AC power cord with other products.

---

2. On the right-hand side of the OmniScan MX / MX1, lift the rubber seal covering the DC adaptor connector plug (Figure 8-1 on page 95).

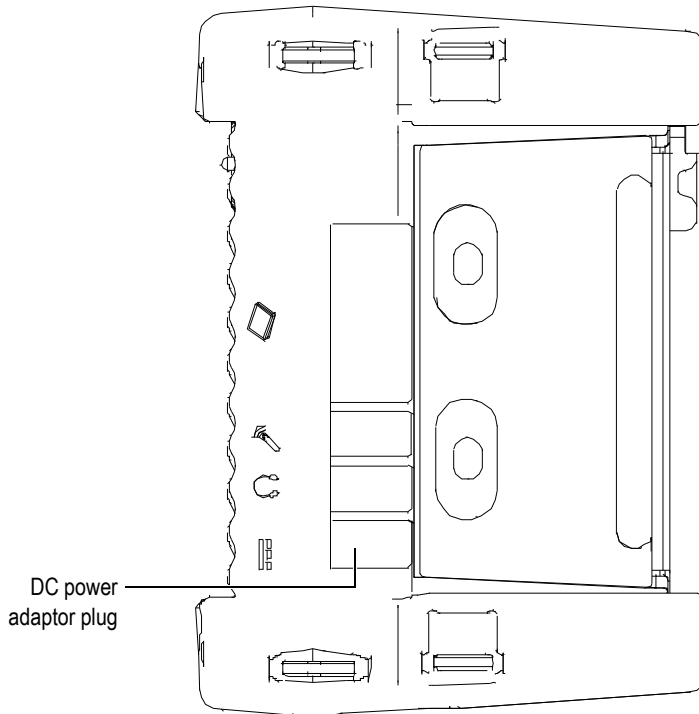

**Figure 8-1 OmniScan MX / MX1 DC power adaptor plug**

3. Connect the DC power adaptor to the OmniScan MX / MX1 DC power adaptor plug (Figure 8-1 on page 95).
4. Press the Power key to start the OmniScan MX / MX1.

## 8.2.2 Lithium-Ion Batteries

The OmniScan MX / MX1 holds up to two lithium-ion batteries, but will operate even with only one battery installed. When two batteries are installed, the OmniScan MX / MX1 operates by default using the battery with the highest charge, and automatically switches to the second battery once the first battery's remaining charge is less than 5 %.

Lithium-ion batteries can be inserted and removed without the need to shut down the OmniScan MX / MX1, provided that there is another valid power source (DC power adaptor or second battery).

The OmniScan MX / MX1 also includes a lithium coin battery that does not need to be removed or replaced by the user. The coin battery keeps the instrument clock and masterboard configuration running.

### 8.2.3 Battery Status Indicators

The battery status indicators located on the upper left corner of the display screen use one of the following two methods to indicate the amount of power remaining in each battery (Figure 8-2 on page 96):

- The remaining operation time is displayed on the battery status indicator. The OmniScan MX / MX1 must be operated for approximately 15 minutes before it is able to accurately display this information.
- The charge indicator (bar) on the battery status indicator shows the approximate amount of power remaining in the battery.

If you attempt to start the OmniScan MX / MX1 using batteries with an insufficient charge, the power indicator light will flash red for approximately three seconds. To operate the OmniScan MX / MX1 you will need to replace the batteries or plug in the DC power adaptor.











**Figure 8-2 Battery charge status: Charge remaining in both batteries**

The battery currently in use is highlighted.

The OmniScan MX / MX1 software keeps the user notified regarding battery status. The battery status indicator variations are described in Table 17 on page 97.



**Table 17 Battery status indicator variations**

Indicator	Outline	Fill	Meaning
	Dotted	N/A	There is no battery in that compartment.
	Blue	Blue	The battery is functioning properly.
	Blue	Orange	The battery is too hot for use.
	Yellow (blinking)	Blue	The battery is charging.
	Orange	Blue	The battery is too hot to be charged.
	Red (blinking)	Blue	The battery charge is critically low (less than 10 %). A beeping noise sounds when there is no spare battery available.
	N/A	Yellow	The OmniScan MX / MX1 is being powered externally through the DC adaptor.
	N/A	Dark green	The external power supply is insufficient.

## 8.2.4 Battery Removal and Installation

### To remove and install a battery

1. Open the battery compartment door on the right side panel of the instrument by pressing the two plastic buttons towards each other.
2. If there is already a battery in the compartment, pull the cloth tab to remove the battery (Figure 8-3 on page 98).

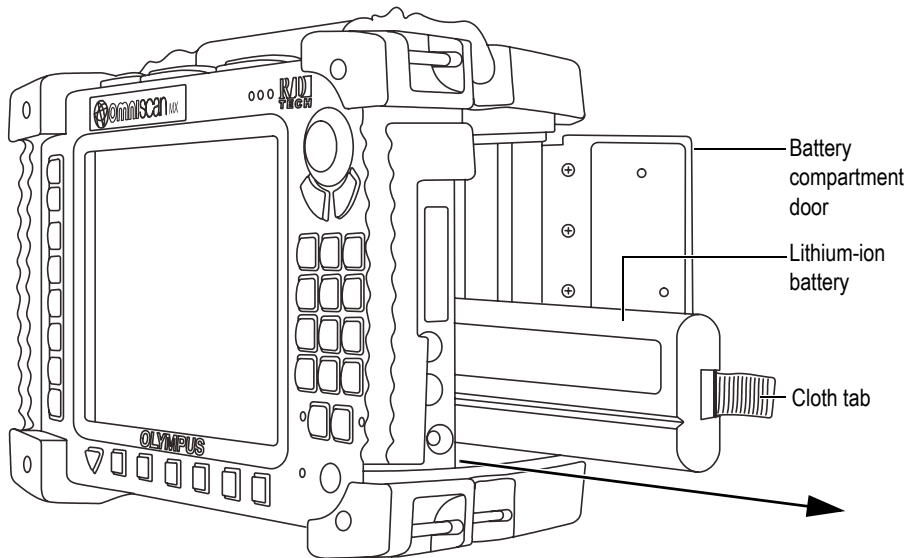

**Figure 8-3 Removing the lithium-ion battery**

3. Insert a new battery. Make sure that the groove on the battery is aligned with the small edge inside the battery compartment.
4. Close the battery compartment door.

The batteries are recharged inside the OmniScan MX / MX1 when it is connected to a DC power adaptor. Connecting an adaptor automatically starts the recharging process. The batteries can also be recharged using an optional external charger.

## 8.2.5 Battery Charging

### To charge the OmniScan MX / MX1 batteries

- ◆ Connect the OmniScan MX / MX1 to a proper DC power adaptor.

Battery charging is performed as follows:

- When the OmniScan MX / MX1 is turned off:

When the OmniScan MX / MX1 is connected to a proper DC power source and is turned off, it will automatically recharge any battery with less than 85 % remaining charge, starting with the weakest battery (if the recharge conditions are met).

The power indicator light indicates which battery is currently being recharged; the light blinks orange/green when recharging battery A, and orange/red when recharging battery B. When the charge is complete, the power indicator light emits a steady orange light. Each battery can take up to 3.5 hours to fully charge from a completely discharged state (less than 5 % remaining charge).

- When the OmniScan MX / MX1 is running:

When the OmniScan MX / MX1 is running and connected to a proper DC power source, it will automatically recharge any battery with less than an 85 % remaining charge, starting with the weakest battery (if the recharge conditions are met).

Because the OmniScan MX / MX1 is running, less power is available from the DC source to recharge the battery or batteries. As such, it could take up to 8 hours to charge each completely discharged battery. For more information about battery charge status, see Table 17 on page 97.

## 8.2.6 Maximizing the Performance of Lithium-Ion Batteries

This section describes lithium-ion battery care and maintenance.

### To store rechargeable batteries

1. Before recharging, drain the batteries by running the OmniScan MX / MX1 on battery power until it shuts down, or until you get a low-battery warning. Do not leave the battery dormant for long periods of time. Evident recommends using the battery at least once every two to three weeks. If a battery has not been used for a long period of time, perform the “New battery procedure” on page 100.

If you do not plan to use the OmniScan MX / MX1 on battery power within three or more weeks, charge the batteries to between 40 % and 80 % capacity (three or four bars on the battery charge indicator), and then remove and store the batteries in a clean, cool, and dry place.

---

<b>NOTE</b>
-------------

Even when the OmniScan MX / MX1 is turned off and unplugged, it draws a small amount of power from the battery, which could completely discharge the batteries in about 15 days.

---

2. Because lithium-ion batteries self-discharge over time, remember to check the remaining charge of any stored batteries approximately once a month to ensure that they have 40 % to 80 % remaining capacity, and recharge any that do not. Failure to do so may render a battery permanently unusable if it falls below a critical level (less than 1 %).
3. After an extended period of storage, the batteries should be fully recharged before use.

### **New battery procedure**

1. Anytime you acquire a new rechargeable battery, use it four to eight times consecutively in the OmniScan MX / MX1, and ensure that you completely discharge and recharge it after each use. Doing so will enable it to reach maximum capacity, providing maximum run time.
2. It is good practice to completely discharge and recharge the battery after the first 10 to 15 periods of normal use (or after two to three weeks) in order to drain the battery, thus maintaining good run time and maximizing battery life.
3. Frequently switching from external DC power to battery power and vice versa may result in shorter battery life, because the charge/discharge cycles are limited (approximately 300 cycles). Please note that even a partial discharge and recharge of the battery accounts for one cycle.
4. To maximize battery life, before recharging, always run the OmniScan MX / MX1 on battery power until it shuts down, or until you get a low-battery warning. Recharge the battery with the OmniScan MX / MX1 turned-off mode for a shorter recharge time, or with the external charger if provided.

### **8.2.7 Used Battery Disposal**

Although lithium-ion batteries do not contain any environmentally hazardous components such as lead or cadmium, the batteries should be disposed of in accordance with local regulations. Batteries should be disposed of in a discharged state to avoid heat generation, and if applicable, in accordance with the European Directive on Waste Electrical and Electronic Equipment (WEEE). Refer to your local Evident distributor for return and/or collection systems available in your country.

### **8.2.8 Warnings on Battery Use**

Carefully read and observe the following warnings on battery use.

**WARNING**

- Do not open, crush, or perforate batteries; doing so could cause injury.
  - Do not incinerate batteries. Keep batteries away from fire and other sources of extreme heat. Exposing batteries to extreme heat (over 80 °C [-4 °F to 140 °F]) could result in an explosion or personal injury.
  - Do not drop, hit, or otherwise abuse a battery, as doing so could expose the cell contents, which are corrosive and explosive.
  - Do not short-circuit the battery terminals. A short circuit could cause injury and severe damage to a battery, making it unusable.
  - Do not expose a battery to moisture or rain; doing so could cause an electric shock.
  - Only use the OmniScan MX / MX1 or an external charger approved by Evident to charge the batteries.
  - Do not recharge a battery unless the indicators light up when the capacity check button on the battery is pressed. Doing so could be dangerous.
  - Do not store batteries that have less than 40 % remaining charge. Recharge batteries to between 40 % and 80 % capacity before storing them.
  - During storage, keep the battery charged to between 40 % and 80 %.
  - Do not leave batteries in the OmniScan MX / MX1 during instrument storage.
- 

### 8.3 Peripheral Connection

Evident recommends shutting down the OmniScan MX / MX1 before installing any peripherals other than USB-compatible peripherals, which do not require a shutdown.

---

<b>IMPORTANT</b>
------------------

The OmniScan MX / MX1 has been tested and found to comply with the radio-frequency limits applicable to industrial devices, in accordance with the specifications of the EMC directive. To maintain OmniScan MX / MX1 compliance with the emissions specifications of the EMC directive, the following conditions must be respected:

- All cables used to connect the equipment must have an overall shielding to ensure electromagnetic compatibility and optimal performance.
  - Ferrite clamp filters must be attached to all cables connected to the OmniScan MX / MX1. For details, see “Ferrite clamp filters” on page 102.
- 

### **Ferrite clamp filters**

Before using the OmniScan MX / MX1, attach the ferrite clamp filters (supplied with the instrument) to the peripheral cables that will be connected to the OmniScan MX / MX1 unit and its modules. The optional peripherals are as follows:

- Evident array probe (ultrasound and eddy current)
- 19-pin eddy current probe
- USB
- Ethernet network
- Scanner interface
- Alarm and I/O

If the ferrite clamp filters are not attached, the OmniScan MX / MX1 will fail to comply with the international and European electromagnetic emission specifications.

### **To attach the clamp filters**

---

<b>IMPORTANT</b>
------------------

- Make sure that the cable is not clamped in between the pawls of the ferrite clamp filter.

- Attach the ferrite clamp filters as closely as possible to the cable ends. The ferrite clamp filters are not effective unless they are immediately adjacent to the cable end connected to the OmniScan MX / MX1.
- Use the ferrite clamp filter with the corresponding cable diameter. The filter must not slip easily or be difficult to clip onto the cable.
- Make sure that the two ferrite clamp-filter parts are closed tight until the clamp clicks.

1. Attach the ferrite clamp filter on the cable of the Evident array probe (ultrasound or eddy current, as applicable), in close proximity to the connector for the OmniScan MX / MX1.
2. Attach the ferrite clamp filter to the cable of the Evident 19-pin eddy current probe (4CH/MUX), in close proximity to the connector for the OmniScan MX / MX1.
3. Attach the ferrite clamp filter to the USB cable, in close proximity to the connector for the OmniScan MX / MX1.
4. Attach the ferrite clamp filter to the Ethernet cable, in close proximity to the connector (RJ-45) for the OmniScan MX / MX1.
5. Attach the ferrite clamp filter to the scanner interface cable, in close proximity to the connector (DE-15) for the OmniScan MX / MX1.
6. Attach the ferrite clamp filter to the alarm and I/O cable, in close proximity to the connector (DE-9) for the OmniScan MX / MX1.

Figure 8-4 on page 103 and Figure 8-5 on page 104 show the applicable connection for various cables on the OmniScan MX / MX1, and the locations where the ferrite clamp filters must be attached.

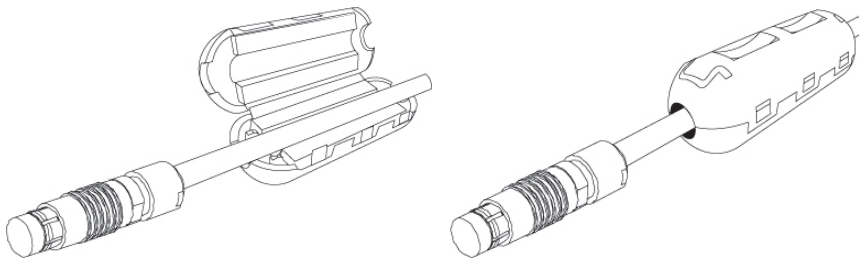

**Figure 8-4 Attaching a ferrite clamp filter to a cable (example shown with the 4CH/MUX cable)**

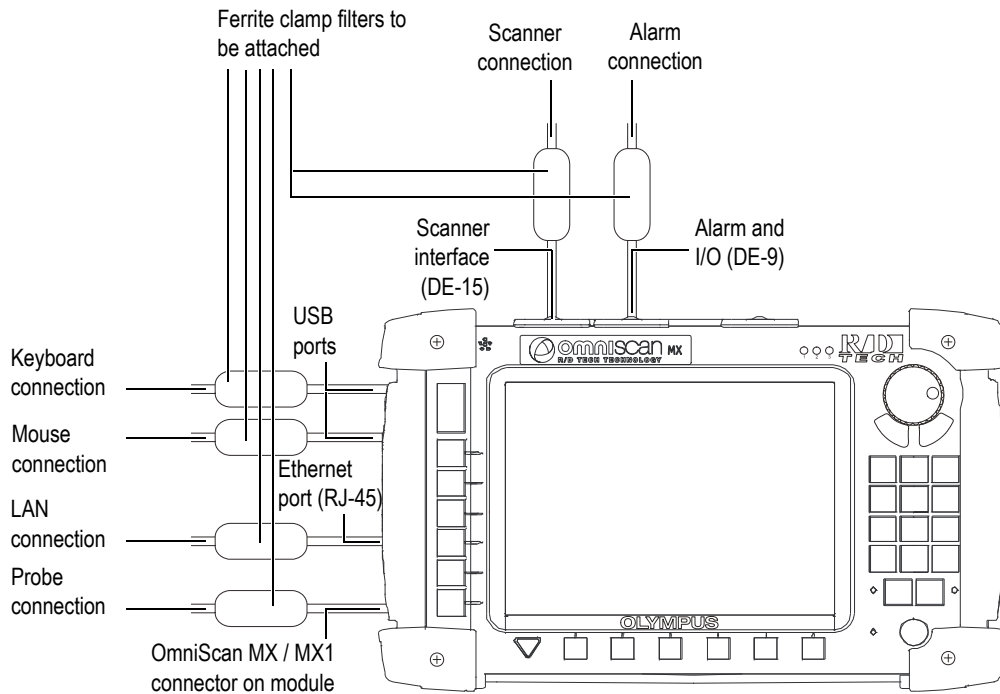

**Figure 8-5 OmniScan MX / MX1 connection diagram indicating where to attach ferrite clamp filters**

## 8.4 OmniScan Software Installation

The OmniScan software installation is designed to be as trouble-free as possible. The software is stored on a CompactFlash card.

If you are using multiple technologies (conventional ultrasonics, phased arrays, conventional eddy current testing, eddy current arrays), it is possible to obtain a single CompactFlash card containing all the software programs.

During upgrades to new versions, a message appears on the screen to inform you that the upgrade is taking place. However, no action is required on your part.

Refer to the Evident website for software updates and all related, applicable procedures.





**CAUTION**

For application versions prior to 1.7, the OmniScan software update overwrites the User folder. You must follow the software installation procedure applicable to your software version before proceeding with the software update. Failing to follow this procedure could result in the loss of valuable user files and data.

---



---

## 9. Maintenance

---

This chapter describes the basic maintenance that must be performed on the OmniScan MX / MX1 unit by operators. The maintenance operations explained below enable you to keep your instrument in good physical and working condition. By virtue of its design, the OmniScan MX / MX1 only requires minimal maintenance. The chapter covers preventative maintenance and instrument cleaning.

### 9.1 Preventative Maintenance

The OmniScan MX / MX1 does not have many moving parts, and therefore only requires minimal preventative maintenance. Simply perform regular inspections to keep the OmniScan MX / MX1 in proper working order.

### 9.2 Instrument Cleaning

The OmniScan MX / MX1 external surfaces (which includes the casing, the acquisition module, and the LCD screen protector) may be cleaned as needed. This section provides the appropriate procedure for cleaning the instrument.

#### 9.2.1 Casing and Acquisition Module Cleaning

##### To clean the casing and acquisition module

1. Make sure that the instrument is turned off, the power cord is disconnected, and the batteries have been removed.
2. Disconnect all cables and connectors, and make sure that all external ports on the OmniScan MX / MX1 have been covered with their rubber protectors.

3. Make sure that the battery compartment door is closed correctly, and that an acquisition module has been installed on the OmniScan MX / MX1.
4. To restore the instrument's original finish, clean the casing and module with a soft cloth.
5. To remove persistent stains, use a damp cloth with a mild, soapy solution. Do not use abrasive products or powerful solvents, which could damage the finish.
6. Once the connector protectors are removed, make sure the connectors are dry before connecting anything else to them. If they are wet, dry them with a soft, dry cloth, or let them air dry.

### **9.2.2 LCD Screen Protector Cleaning**

Never use abrasive products or powerful solvents to clean the OmniScan MX / MX1 screen. Clean the screen using a damp cloth moistened with windshield washer fluid. If you do not have windshield washer fluid, use a standard, evaporating glass cleaner. If necessary, remove any paper-towel residue with a soft-bristle brush.

---

## 10. Troubleshooting

---

This chapter will help you resolve minor problems that could occur during operation of your OmniScan MX / MX1 unit. This troubleshooting guide has been prepared based on the assumption that the instrument has not been modified, and that all cables and connectors used are those provided and documented by Evident.

### 10.1 Start-Up Problems

The OmniScan MX / MX1 does not start.

#### Possible solutions

- Check that the DC power adaptor is connected to both the OmniScan MX / MX1 and a power outlet with the proper voltage. Use only the adaptor supplied with the OmniScan MX / MX1.
- Make sure that there is at least one battery charged to at least 10 % capacity and correctly inserted into the battery compartment.
- Press and hold the Power key (  ) for three seconds or longer.

### 10.2 Messages

Messages appear during the start-up sequence (Table 18 on page 110).

**Table 18 Messages**

<b>Message</b>	<b>Solution</b>
<b>No module detected</b>	Make sure that you have an acquisition module correctly attached to the base unit.
<b>Error downloading code</b>	Restart the OmniScan MX / MX1.
	Make sure that the software is up-to-date.

### 10.3 Battery Charging Problems

The batteries do not charge when placed in the OmniScan MX / MX1.

#### Possible solutions

- Make sure that the battery model used in the OmniScan MX / MX1 is compatible with the model suggested by Evident. An incompatible battery may be able to power the unit, but the recharge protocol may not recognize it.
- Make sure that the DC power adaptor is connected correctly.
- Charge the batteries using an external charger. Batteries charge much quicker when the OmniScan MX / MX1 is not in use. However, the batteries will charge very slowly, if at all, if the power consumption is too high.
- Shut down the OmniScan MX / MX1 and wait for it to cool. The internal charger is equipped with a temperature monitor to prevent batteries from being recharged when the internal temperature is too high.

### 10.4 Battery Life Problems

The battery charge does not last as long as it used to.

#### Possible solutions

- Drain the batteries completely before recharging them to extend their life.
- Recondition the batteries once a month using an external battery charger. Although lithium-ion batteries do not suffer from the “memory effect” commonly affecting other battery types, they should be reconditioned for optimum

efficiency (for details, see “Maximizing the Performance of Lithium-Ion Batteries” on page 99).

- Verify your current configuration. There may be an option or combination of options that are causing the batteries to drain the batteries too quickly. Such options could include the backlight, voltage level, and acquisition rate.

## 10.5 Memory Card Problems

Problems are encountered when reading or writing a file from or to the memory card.

### Possible solutions

- Check that the memory card was inserted correctly into its slot.



#### CAUTION

The OmniScan MX / MX1 memory card slot could be damaged if you force the memory card the wrong way.

- If the memory card was removed while the OmniScan MX / MX1 was active, especially if data was being read or written at the time, data corruption may have occurred.



#### CAUTION

There is a slight possibility that removing the memory card while the OmniScan MX / MX1 is active could cause problems, especially if data is being read or written at the time of removal. These problems can range from a software crash to data loss, or even memory-card corruption.

- Make sure that there is enough space left on the memory card to store the data you are trying to save. Evident provides memory cards with various storage capacities. You may require a memory card with a larger storage capacity.
- Check your memory card to make sure that it is correctly formatted. In most cases, new cards are not formatted when purchased. A PC and CompactFlash memory card reader (USB or PCMCIA) are required to format memory cards in FAT32 format.

- Make sure your data is not corrupted. Several factors can cause data corruption. The most common factors are incomplete data transfer, electrostatic discharges, and removal of the memory card while the OmniScan MX / MX1 is active. Oftentimes, the only way to fix the problem is to delete the problem file(s), or to reformat the memory card.



### **CAUTION**

Create backup files before reformatting any memory cards. Reformatting causes all data on the memory card to be lost.

---

## **10.6 Headphone or Speaker Problems**

### **10.6.1 Internal Speaker**

The internal speaker does not work.

#### **Possible solution**

- Make sure that no headphones or external speakers are plugged into the headphone jack, as they disable the internal speaker.

### **10.6.2 Headphones or External Speakers**

The headphones or external speakers do not work.

#### **Possible solution**

- Make sure that the headphones or external speakers are plugged into the headphone jack correctly.

## **10.7 Video Input Problems**

The video input does not function.



### **Possible solutions**

- Make sure that the instrument is equipped with the video input option.
- Make sure that the video cable is correctly connected.

## **10.8 Video Output Problems**

The video output does not function.

### **Possible solutions**

- Make sure that the video output option, which must be purchased separately, is available.
- Make sure that the video cable is connected correctly.
- Make sure that the external video monitor can support a resolution of 800 × 600 pixels in VGA mode.
- Make sure that your monitor supports the VGA standard. The VGA standard requires the removal of pin 9 from the video connector. While the OmniScan MX / MX1 meets this requirement, some monitors do not. If pin 9 has not been removed from your monitor connector, you will need to remove it. Evident is not responsible for any potential damage that may result from pin removal.

## **10.9 Networking Problems**

Ethernet communication is unavailable.

### **Possible solutions**

- Make sure that the Ethernet option, which must be purchased separately, is available.
- Make sure that the Ethernet cable is connected correctly.
- Make sure that you have installed the software that is required for communication between the PC and the OmniScan MX / MX1.

## 10.10 USB Peripheral Problems

Some USB peripherals do not function when connected to the OmniScan MX / MX1.

### Possible solutions

- Only use a standard USB mouse.
- Only use a standard USB keyboard.
- Only use external storage devices that adhere to the USB Mass Storage specification.
- If a printer is malfunctioning, make sure that it is compatible with the OmniScan MX / MX1 (for a list of compatible printers, contact your local Evident representative).

## 10.11 Boot Problems

### 10.11.1 A-Scan Display

The OmniScan software boots up, but no A-scan is displayed.

### Possible cause

The BIOS version used is probably greater than 1.04B, but the fix for the old BIOS command **BIOS 1.04 Rev B.cmd** has been executed.

### Solution 1

Correct the BIOS version as follows:

1. Insert a CompactFlash memory card (with valid OmniScan software on it) in a memory card reader connected to a computer.
2. On the memory card, search for a directory named **Run the Fix for old BIOS**.
3. Run the **Undo Fix.cmd** program.  
This removes incompatible files.
4. Insert the memory card into the OmniScan MX / MX1, and then start the OmniScan MX / MX1 using the usual start-up procedure.

## Solution 2

Correct the BIOS version as follows:

- ◆ Delete the contents of the memory card, and then, without running the **BIOS 1.04 Rev B.cmd** command, copy a clean version of the software onto it.

### 10.11.2 OmniScan MX / MX1 Start-Up

The OmniScan logo is displayed with the BIOS version and an exclamation point (!), but the OmniScan MX / MX1 fails to start.

#### Possible cause

A CompactFlash memory card containing files necessary for the old BIOS version has been used in the OmniScan MX / MX1, and the BIOS is in monitor mode.

#### Solution

Update the BIOS version as follows:

1. Insert a CompactFlash memory card containing valid OmniScan software into a memory card reader connected to a computer.
2. On the memory card, search for a directory named **Run the Fix for old BIOS**.
3. Run the **Reset CMOS.cmd** program to create the necessary files on the memory card.
4. Start the OmniScan MX / MX1 with the memory card. You should see the exclamation point (!) displayed, but nothing else.  
This operation resets the CMOS parameters.
5. Take the memory card out of the OmniScan MX / MX1 and reinsert it into the reader.
6. Search for the directory named **Run the Fix for old BIOS**.
7. Run the **Undo Reset CMOS.cmd** program to remove unnecessary files on the memory card.
8. Start the OmniScan MX / MX1 with the memory card.  
The instrument should now start normally.



## 11. Specifications

This chapter covers the OmniScan MX / MX1 unit specifications. It includes the general specifications for the instrument, in addition to the specifications applicable to alarms and safety (Table 19 on page 117 and Table 20 on page 119).

### NOTE

For the specifications applicable to specific acquisition modules, please refer to the respective appendices at the end of this manual.

**Table 19 OmniScan MX / MX1 general specifications**

<b>Housing</b>	
Size	321 mm × 209 mm × 125 mm (12.6 in. × 8.2 in. × 5 in.)
Weight	2.8 kg (6.2 lb) [no module and one battery] 4.6 kg (10.1 lb) [module and one battery]
<b>Environmental conditions</b>	
Operating temperature	0 °C to 40 °C [32 °F to 104 °F]
Storage temperature	-20 °C to 60 °C [-4 °F to 140 °F]
Relative humidity	Max. 85 % RH at 40 °C [104 °F] noncondensing
Altitude	Up to 2000 m
Outdoor use	With batteries only
Pollution level	2
<b>Batteries</b>	
Battery model	OMNI-A-BATT (U8760010)

**Table 19 OmniScan MX / MX1 general specifications (continued)**

Battery type	Smart lithium-ion batteries
Number of batteries	1 or 2
Battery storage temperature	-20 °C to 60 °C [-4 °F to 140 °F] ≤ 1 month -20 °C to 45 °C [-4 °F to 113 °F] ≤ 3 months
Battery charge time	<3.5 hours using the internal battery charger or an optional battery charger
Battery life	Minimum 6 hours with two batteries; minimum 3 hours per battery under normal operating conditions
Size	119 mm × 60 mm × 32 mm, ±1 mm (4.69 in. × 2.36 in. × 1.26 in., ±0.04 in.)
<b>External DC supply</b>	
DC-IN voltage	15 VDC to 18 VDC (min. 50 W)
Connector	Circular, 2.5 mm pin diameter, center-positive
Suggested model	OMNI-A-AC (U8767093)
<b>Display</b>	
Display size (diagonal)	213 mm (8.4 in.)
Resolution	800 × 600 pixels
Number of colors	16 million
Type	TFT LCD visible from any angle
<b>Data storage</b>	
Storage devices	Optional CompactFlash card, most standard USB storage devices, or through optional fast Ethernet
Maximum data file size	Limited to available internal flash memory: 180 MB (or 300 MB optional)
<b>I/O ports</b>	
USB ports	3 USB 1.1 ports, rated 500 mA output current
Speaker out	Yes, mono, minimum of 8 Ω total impedance
Video output	Video out (SVGA)
Video input	Video input (NTSC/PAL)
Ethernet	10/100 Mbps (megabits per second)

**Table 19 OmniScan MX / MX1 general specifications (continued)**

<b>I/O lines</b>	
Encoder	2-axis encoder line (quadrature or clock/direction)
Digital input	2 digital inputs TTL, 5 V
Digital output	4 digital outputs TTL, 5 V, 15 mA maximum per output
Remote communication	Remote communication RS-232 or RS-485
Acquisition on/off switch	Remote acquisition enable TTL, 5 V
Power output line	5 V nominal, 500 mA nominal power output line (short-circuit protected)
Alarms	3 TTL, 5 V, 15 mA maximum.
Analog output	2 analog outputs (12-bit resolution) $\pm 5$ V nominal in 10 k $\Omega$ , 10 mA maximum per output
Pace input	5 V, TTL pace input

**Table 20 OmniScan MX / MX1 alarms**

<b>Alarms</b>	
Number of alarm zones	3
Conditions	Any logical combination of gates
Analog outputs	2







## 12. Connector References



### WARNING

Always use equipment and accessories that meet Evident specifications. Using incompatible equipment can result in a malfunction, equipment damage, or injury.

This chapter provides a technical description of the three OmniScan MX / MX1 unit connectors below:

- “Serial Connector” on page 122 ()
- “Scanner Interface Connector” on page 123 ()
- “Alarm and I/O Connector” on page 126 ()

The following information is provided for each of these connectors: a brief description, the manufacturer’s number, the number of the corresponding cable connector, an illustration, and a table with the signal pinout for the connector.

The following OmniScan MX / MX1 connectors comply with their respective standards:

- CompactFlash PCMCIA (memory card slot)
- Audio output (headphone jacks)
- Circular DC power jack, 2.5 mm pin diameter, 15 VDC to 18 VDC (polarity: )
- USB
- Ethernet (RJ-45)

- VGA

## 12.1 Serial Connector

### Description

Mini-DIN, female connector

### Manufacturer, number

Kycon, KMDG-8S-BS

### Suggested cable connector

Kycon, KMDLA-8P

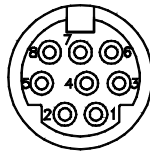

Figure 12-1 Serial connector

Table 21 Pinout for the serial connector

Pin	I/O	Signal	Description	Level
1	In	Video in	Video input	1 V p-p
2	–	NC	No connection	
3	–	SOUT2	Serial out	RS-232
4	–	GND	Ground	
5	–	SIN2	Serial in	RS-232
6	–	NC	No connection	
7	–	+9 to 12 V	500 mA max.	
8	–	NC	No connection	

## 12.2 Scanner Interface Connector

### Description

DE-15, female connector

### Manufacturer, number

Kycon, K61-E15S-NS

### Suggested cable connector

Conec, 301A10129X

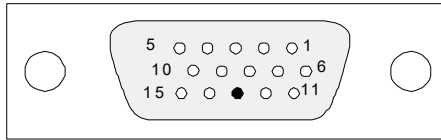

Figure 12-2 Scanner interface connector

Table 22 Pinout for the scanner interface connector

Pin	I/O	Signal	Description	Current	Level
1	In	DIN1/ Preset1	Digital input 1/preset axis 1.  Programmable input. Can be configured as generic input 1, or as the preset of encoder 1. Refer to the OmniScan software user's manuals ("Configuring the Digital Input") for instructions on programming this input.  To preset, you must use a high-level signal with a minimum signal length of 50 ms.		TTL

**Table 22 Pinout for the scanner interface connector (continued)**

Pin	I/O	Signal	Description	Current	Level
2	In	DIN2/ Preset2	Digital input 2/preset axis 2.  Programmable input. Can be configured as generic input 2, or as the preset of encoder 2. Refer to the OmniScan software user's manuals ("Configuring the Digital Input") for information on programming this input.  To preset, you must use a high-level signal with a minimum signal length of 50 ms.		TTL
3	Out	+5 V	External power supply	500 mA	
4	In	AIN	Analog input		±5 V
5	In	DIN3/ AcqEn	Digital input 3/acquisition enable.  Programmable input. Can be configured as generic input 3, or as an acquisition-enabled signal (enabled at a high level with a minimum signal length of 50 ms). By default, configured as generic input 3. Refer to the OmniScan software user's manuals ("Configuring the Digital Input") for information on programming this input.		TTL

**Table 22 Pinout for the scanner interface connector (continued)**

Pin	I/O	Signal	Description	Current	Level
6	Out	DOUT1/ PaceOut	Digital out 1/pace output	±15 mA	TTL
7	In	RRX	Rx		RS-232/485
8	Out	RTX	Tx		RS-232/485
9	In	PhA axis 1	Encoder 1: phase A/clock / up/down.		TTL
10	In	PhB axis 1	Encoder 1: phase B/direction/N.U./ N.U. <sup>a</sup>		TTL
11	In	PhA axis 2	Encoder 2: phase A/clock/up/down.		TTL
12	In	PhB axis 2	Encoder 2: phase B/direction/N.U./ N.U.		TTL
13	–		Key		
14	Out	DOUT2	Digital output 2	±15 mA	TTL
15	–	GND	Ground		

a. N.U. = Not used

## 12.3 Alarm and I/O Connector

### Description

DE-9, female connector

### Manufacturer, number

Amphenol, 788797-1

### Suggested cable connector

ITT Cannon, DE-9P

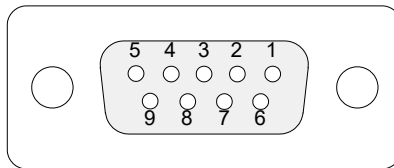

Figure 12-3 Alarm and I/O connector

Table 23 Pinout for the alarm and I/O connector

Pin	I/O	Signal	Description	Current	Level
1	Out	A11	Alarm output 1. Disabled on reset, and is at 0 V. When active, it is at 5 V.	±15 mA	TTL
2	Out	A12	Alarm output 2. Disabled on reset, and is at 0 V. When active, it is at 5 V.	±15 mA	TTL
3	Out	A13	Alarm output 3. Disabled on reset, and is at 0 V. When active, it is at 5 V.	±15 mA	TTL
4	Out	AOUT1	Analog output 1	±15 mA	±5 V
5	Out	AOUT2	Analog output 2	±15 mA	±5 V
6	–	GND	Ground		

**Table 23 Pinout for the alarm and I/O connector (continued)**

Pin	I/O	Signal	Description	Current	Level
7	Out	DOUT4	Digital output 4	±15 mA	TTL
8	Out	DOUT3	Digital output 3	±15 mA	TTL
9	In	DIN4/ ExtPace	Digital input 4/external pace input. Programmable input. Can be configured as generic input 4, or as external pace input (high level with a minimum signal length of 50 ms when used as DIN4, or 21 µs as ExtPace). Refer to the OmniScan software user's manuals ("Configuring the Digital Input") for information on programming this input.		TTL





## Appendix A: Compatibility Tables



### WARNING

Always use equipment and accessories that meet Evident specifications. Using incompatible equipment can result in a malfunction, equipment damage, or injury.

This appendix presents the modules, software, and accessories that are compatible with the OmniScan MX2 and the OmniScan MX / MX1 (Table 24 on page 129 to Table 28 on page 131).

**Table 24 Module compatibility**

Module model	Part number	OMNI-MX2	OMNI-MX	OMNI-MX1
OMNI-M-PA1616M	U8100019	No	Yes	No
OMNI-M-PA1664M	U8100020	Yes	Yes	No
OMNI-M-PA1616	U8100018	No	Yes	No
OMNI-M-PA1664	U8100087	No	No	No
OMNI-M-PA16128	U8100029	No	Yes	No
OMNI-M-PA16128PR	U8100017	No	Yes	No
OMNI-M-PA32128	U8100021	Yes	Yes	No
OMNI-M-PA32128PR	U8100022	Yes	Yes	No
OMNI-M-UT	All models	Yes	Yes	No
OMNI-M-ECT/ECA	All models	No	Yes	Yes
OMNI-M1-ECA4-32	Q2700052	No	Yes	Yes
OMNI-M2-PA1664	U8100121	Yes	No	No

**Table 24 Module compatibility (continued)**

Module model	Part number	OMNI-MX2	OMNI-MX	OMNI-MX1
OMNI-M2-PA16128	U8100122	Yes	No	No
OMNI-M2-PA32128	U8100123	Yes	No	No
OMNI-M2-PA32128PR	U8100145	Yes	No	No
OMNI-M2-UT-2C	U8100131	Yes	No	No

**IMPORTANT**

The software versions mentioned in Table 25 on page 130 and Table 26 on page 131 were the versions available at the time of the publication. Subsequent qualified versions will also be compatible.

**Table 25 OmniScan MX2 software compatibility**

Module	Acquisition	Analysis
UT	MXU 3.1R3 <sup>a</sup> TomoView 2.10R5 with OSTV 3.0	OmniPC 3.1R3 <sup>a</sup> TomoView 2.10R5
PA	MXU 4.1 <sup>b</sup> TomoView 2.10R5 with OSTV 3.0	OmniPC 4.1 <sup>b</sup> TomoView 2.10R5
UT2	MXU 4.1	OmniPC 4.1 <sup>b</sup> TomoView 2.10R5
PA2	MXU 4.1 <sup>b</sup>	OmniPC 4.1 <sup>b</sup> TomoView 2.10R5

- a. Not compatible with version later than 3.1.
- b. MXU 3.2 and OmniPC 3.2 are also compatible.

**Table 26 OmniScan MX / MX1 software compatibility**

Module	Acquisition	Analysis
UT	MXU 2.0R27 TomoView 2.10R5 with OSTV 1.7 <sup>a</sup>	OmniPC 3.1R3 TomoView 2.10R5
PA	MXU 2.0R27 TomoView 2.10R5 with OSTV 1.7 <sup>a</sup>	OmniPC 4.1 <sup>b</sup> TomoView 2.10R5

- a. Not compatible with version later than 3.1.  
b. OmniPC 3.2 also compatible.

**Table 27 Old accessory compatibility**

Accessories	Part number	OMNI-MX2	OMNI-MX and OMNI-MX1
OMNI-A-ADP03, Hypertronic to OmniScan connector adaptor	U8767014	Using E128P extension cables: yes	Yes
OMNI-A-ADP05, PA Y-Adaptor	U8767016	Using E128P extension cables: yes	Yes
OMNI-A-ADP11, 8UT to OmniScan connector adaptor	U8767019	Using E128P extension cables: yes	Yes
Scanners with DE-15 encoder connectors	All models	Using DE-15 to LEMO adaptor: yes	Yes

**Table 28 New accessories compatibility**

Accessories	Part number	OMNI-MX2	OMNI-MX and OMNI-MX1
OMNI-A2-ADP03, Hypertronic to OmniScan connector adaptor	U8775202	Yes	Yes
Encoder adaptor to connect scanners with DE-15 connectors to MX2 with LEMO connector	U8775201	Yes	No

**Table 28 New accessories compatibility (continued)**

<b>Accessories</b>	<b>Part number</b>	<b>OMNI-MX2</b>	<b>OMNI-MX and OMNI-MX1</b>
Encoder adaptor to connect scanners with LEMO connectors to MX with DE-15 connector	U8780329	No	Yes

---

## Appendix B: Acquisition Module Description and Replacement Procedures

---

This appendix outlines the following items: the general specifications for the modules and connectors, the procedure for replacing and connecting an acquisition module used with the OmniScan MX / MX1 and OmniScan MX2 units, and the procedure for cleaning a module fan filter.

### B.1 General Specifications

Table 29 on page 134 lists the general specifications common to all acquisition modules, except the OMNI-M2-PA1664, OMNI-M2-PA16128, OMNI-M2-PA32128 and OMNI-M2-PA32128PR modules. For general specifications for the OMNI-M2-PA1664, OMNI-M2-PA16128, OMNI-M2-PA32128 and OMNI-M2-PA32128PR modules, see Table 30 on page 134. Finally, Table 31 on page 135 lists the general specifications for the OMNI-M2-UT-2C module.

**Table 29 General specifications for all modules**

Specifications	Modules	
		OMNI-M-UT-2C OMNI-M-UT-4C OMNI-M-UT-8C OMNI-M-PA1616M OMNI-M-PA1664M OMNI-M-PA1616 OMNI-M-PA16128 OMNI-M-PA16128PR OMNI-M-ECA4-32 OMNI-M1-ECA4-32
Overall dimensions	244 mm × 182 mm × 57 mm (9.62 in. × 7.17 in. × 2.15 in.)	250 mm × 190 mm × 57 mm (9.84 in. × 7.48 in. × 2.15 in.)
Weight	1.2 kg (2.6 lb)	1.38 kg (3 lb)
Probe recognition	Automatic probe recognition and setup	
Operating temperature	0 °C to 40 °C [32 °F to 104 °F]	0 °C to 35 °C [32 °F to 95 °F]
Storage temperature	-20 °C to 70 °C [-4 °F to 158 °F]	
Relative humidity	95 % noncondensing	

**Table 30 General specifications – OMNI-M2-PA1664/16128 /32128/32128PR**

Specifications	Modules	
		OMNI-M2-PA-1664 OMNI-M2-PA-16128 OMNI-M2-PA-32128 OMNI-M2-PA-32128PR
Overall dimensions	226 mm × 183 mm × 40 mm (8.9 in. × 7.2 in. × 1.6 in.)	
Weight	1.6 kg (3.5 lb)	

**Table 30 General specifications – OMNI-M2-PA1664/16128  
/32128/32128PR (continued)**

Specifications	Modules
	OMNI-M2-PA-1664 OMNI-M2-PA-16128 OMNI-M2-PA-32128 OMNI-M2-PA-32128PR
Probe recognition	Automatic probe recognition and setup
Operating temperature	-10 °C to 45 °C [14 °F to 113 °F]
Storage temperature	-20 °C to 70 °C [-4 °F to 158 °F]
Relative humidity	Max. 70 % RH at 45 °C [113 °F] noncondensing
Connectors	Phased array connector: Evident PA connector
	UT connector: LEMO 00

**Table 31 General specifications – OMNI-M2-UT-2C**

Specifications	Module
	OMNI-M2-UT-2C
Overall dimensions	226 mm × 183 mm × 40 mm (8.9 in. × 7.2 in. × 1.6 in.)
Weight	1.6 kg (3.5 lb)
Probe recognition	N/A
Operating temperature	-10 °C to 45 °C [14 °F to 113 °F]
Storage temperature	-20 °C to 70 °C [-4 °F to 158 °F]
Relative humidity	Max. 70 % RH at 45 °C [113 °F] noncondensing
Connectors	LEMO 00

## B.2 Connectors

Certain acquisition modules are equipped with one phased array connector; certain modules are equipped with BNC connectors (only OMNI-M-PA1616, OMNI-M-PA1664, OMNI-M-PA16128, OMNI-M-PA16128PR, OMNI-M-PA1616M, and OMNI-M-PA1664M modules) or LEMO connectors (OMNI-M-UT-8C, OMNI-M2-PA1664, OMNI-M2-PA16128, OMNI-M2-PA32128, OMNI-M2-PA32128PR and OMNI-M2-UT-2C).

R1

BNC or LEMO connector used for the reception of ultrasonic signals when using the pitch-catch inspection technique.

P1

BNC or LEMO connector used for the transmission of ultrasonic signals when using the pitch-catch or the pulse-echo technique.

### PHASED ARRAY

Connector used for phased array probes.

The compatible probe connectors are presented in Figure B-1 on page 136.

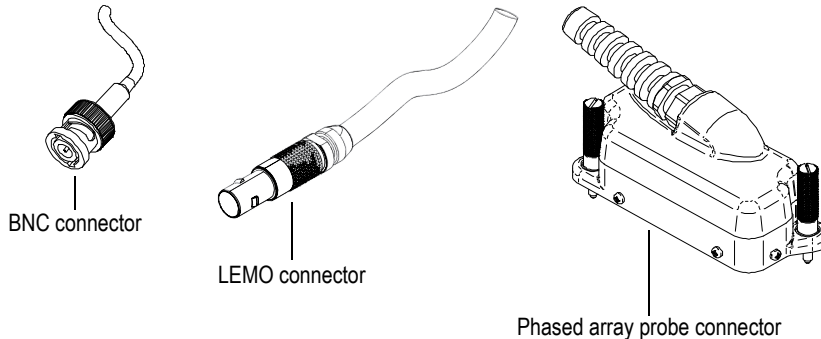

**Figure B-1 BNC, LEMO, and phased array probe connectors**



## B.3 Replacement Procedure

This section outlines the procedure for replacing an acquisition module and connecting the phased array probe to it.



### CAUTION

Do not remove an acquisition module if the OmniScan is turned on. Doing so could damage the circuits and cause any unsaved data to be lost. Always make sure that the OmniScan is shut down before removing any acquisition modules.



### CAUTION

In order to prevent injury, do not place your fingers between the acquisition module and the instrument's stand (when unfolded).

### To replace an acquisition module

1. Shut down the OmniScan.
2. Remove all batteries, and disconnect the DC adaptor if applicable.
3. Place the instrument face down on a stable surface.
4. Unscrew the two captive screws either by hand or using a flathead screwdriver.  
If the captive screws are sufficiently loose, small metal springs cause them to pop out on their own.



### CAUTION

Do not try to remove the captive screws completely, because they are not designed for this purpose. Trying to remove them will result in material damage.

5. Push out the two module retaining hooks (the two plastic levers located on the opposite side of the captive screws) to loosen the module.
6. Remove the module.

7. Align the connector of the new module on top of the OmniScan connector, and then gently press down.
8. Secure the new module with the retaining hooks.
9. Tighten the two captive screws manually, or with a flathead screwdriver.
10. Put the batteries back in the battery compartment, or plug in the DC power adaptor if needed.
11. Connect the phased array probe connector as follows:
  - a) Align the phased array probe connector correctly by matching its guide pins with the PHASED ARRAY module connector (Figure B-2 on page 138).

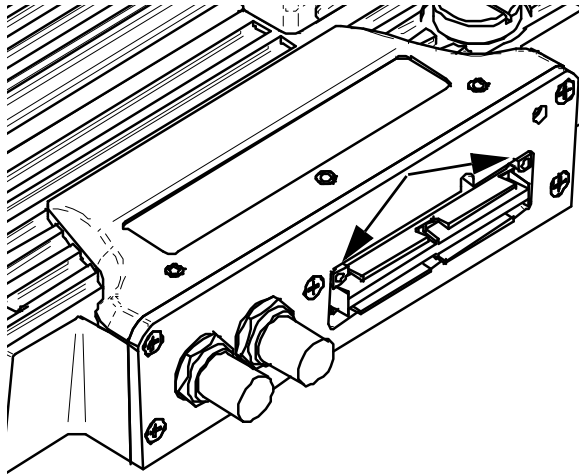

**Figure B-2 Phased array module connector guide location**

- b) Gently press the phased array probe connector into the PHASED ARRAY module connector until it is fully inserted.
- c) Tighten the retaining screws located on each side of the phased array probe connector.

## **B.4 Fan Filter Cleaning Procedure**

This section describes the procedure for cleaning the acquisition module fan filter for models OMNI-M-PA3232, OMNI-M-PA32128, and OMNI-M-PA32128PR.

## To clean the fan filter

1. On the fan grill, remove the screw securing the grill to the module (Figure B-3 on page 139).

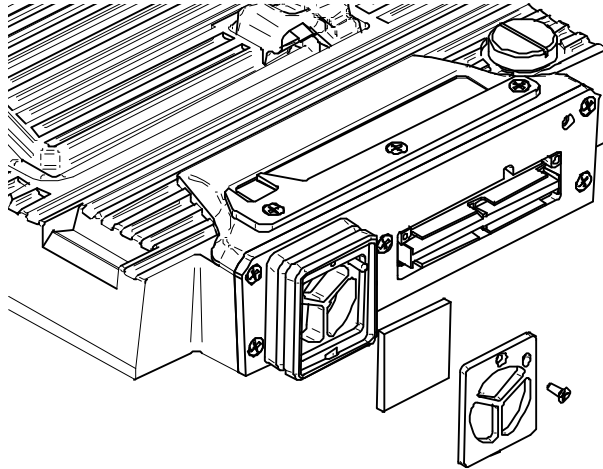

**Figure B-3** Grill and filter of the OMNI-M-PA32mm model

2. Remove the filter.
3. Clean the filter using soap and water.
4. Rinse the filter thoroughly with clean water and allow to dry.
5. Reinstall the filter inside the fan opening.
6. Reinstall the grill, and then secure it with the screw.



---

## Appendix C: OMNI-M-PA32128 Module Specifications

---

This appendix outlines the technical specifications for OmniScan PA acquisition module model OMNI-M-PA32128 (Figure C-1 on page 141).

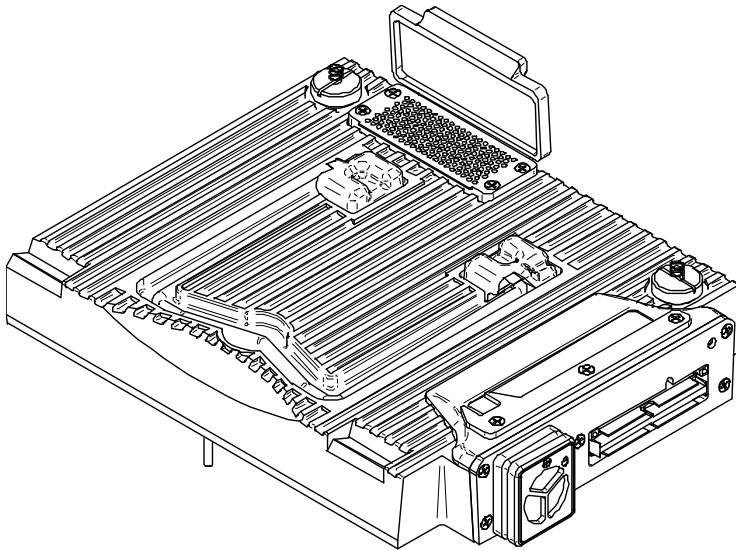

**Figure C-1** Phased array module model OMNI-M-PA32128

## C.1 Acoustic Specifications

This section describes the acoustic specifications for the pulser, receiver, and beam formation (Table 32 on page 142).

**Table 32 Acoustic specifications — OMNI-M-PA32128**

<b>Pulser</b>	
Voltage	Low: 45 V High: 90 V
Pulse width	Adjustable from 30 ns to 500 ns; resolution of 2.5 ns.
Fall time	<5 ns
Pulse shape	Negative square pulse
Output impedance	<30 $\Omega$
<b>Receiver</b>	
Gain range	0 dB to 74 dB in steps of 0.1 dB, maximum input signal 1.25 Vp-p
Input impedance	50 $\Omega$
System bandwidth	0.53 MHz to 21 MHz, $\pm 10\%$ ( $-3$ dB)
<b>Beam formation</b>	
Scan type	Sectorial and linear
Aperture	32 elements
Number of elements	128 elements
Number of focal laws	256
Delay range transmission	0 $\mu$ s to 10 $\mu$ s in 2.5 ns increments
Delay range reception	0 $\mu$ s to 10 $\mu$ s in 2.5 ns increments

## C.2 Acquisition Specifications

This section details the acquisition specifications of frequency, data display, and synchronization (Table 33 on page 143).

**Table 33 Acquisition specifications – OMNI-M-PA32128**

<b>Frequency</b>	
Effective digitizing frequency	Up to 100 MHz (10 bits)
A-scan (acquisition mode)	Up to 6000 A-scans per second (512-point, 8-bit A-scan)
Maximum pulsing rate	Up to 10 kHz (C-scan)
Depth in material	59.8 meters in steel (longitudinal wave), 10 ms with compression 0.49 meters in steel (longitudinal wave), 81.9 $\mu$ s without compression
<b>Display</b>	
Refresh rate	A-scan: 60 Hz; S-scan: 20 Hz to 30 Hz
Envelope (echo-dynamic mode)	Yes: Volume-corrected S-scan (30 Hz)
<b>Synchronization</b>	
On internal clock	1 Hz to 10 kHz
External pace	Yes
On encoder	On 2 axes: from 1 to 65536 steps.

## C.3 Data Specifications

This section details the data specifications of processing, TCG, and storage (Table 34 on page 143).

**Table 34 Data specifications – OMNI-M-PA32128**

<b>Processing</b>	
Number of data points	Up to 8000.
Real-time averaging	2, 4, 8, and 16
Rectification	RF, full wave, half wave+, half wave-

**Table 34 Data specifications – OMNI-M-PA32128 (continued)**

Filtering	Low-pass (adjusted to probe frequency), digital filtering (bandwidth, frequency range)
Video filtering	Smoothing (adjusted to the probe frequency range)
<b>Programmable TCG</b>	
Number of points	16: One TCG (time-corrected gain) curve per channel for focal laws
<b>Storage</b>	
A-scan recording	6000 A-scans per second (512-point, 8-bit A-scan)
C-scan recording	I, A, B, up to 10 kHz
Maximum file size	Limited to available internal flash memory: OmniScan MX / MX1: 180 MB (or 300 MB optional) OmniScan MX2: 300 MB



## Appendix D: OMNI-M-UT-2C, OMNI-M-UT-4C, and OMNI-M-UT-8C Module Specifications

---

This appendix presents the technical specifications for OmniScan UT acquisition module models OMNI-M-UT-2C, OMNI-M-UT-8C (Figure D-1 on page 145), and OMNI-M-UT-4C.

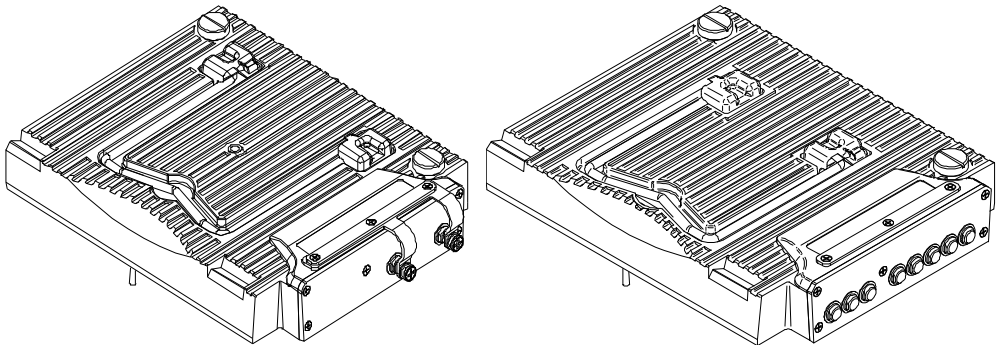

**Figure D-1** Modules OMNI-M-UT-2C (*left*) and OMNI-M-UT-8C (*right*)

## D.1 Acoustic Specifications

This section outlines the number of channels available per acquisition module, and the acoustic specifications for the pulser and the receiver (Table 35 on page 146).

**Table 35 Acoustic specifications – OMNI-M-UT-*n*C**

<b>Number of channels</b>	
Pulse-echo mode	2 channels, OMNI-M-UT-2C 4 channels, OMNI-M-UT-4C 8 channels, OMNI-M-UT-8C
Pitch-catch mode	1 pulser and 1 receiver, OMNI-M-UT-2C 2 pulsers and 2 receivers, OMNI-M-UT-4C 4 pulsers and 4 receivers, OMNI-M-UT-8C
<b>Pulser</b>	
Voltage	50 V, 100 V, 200 V, 300 V
Pulse width	Adjustable from 30 ns to 1000 ns; resolution of 2.5 ns
Fall time	Less than 7 ns
Pulse shape	Negative square pulse
Output impedance	<7 $\Omega$
<b>Receiver</b>	
Receiver gain range	0 dB to 100 dB, maximum input signal 20 V <sub>p-p</sub>
Input impedance	50 $\Omega$
Bandwidth	0.25 MHz to 32 MHz (-3 dB)

## D.2 Acquisition Specifications

This section lists the acquisition specifications for frequency, data display, and synchronization (Table 36 on page 147).

**Table 36 Acquisition specifications – OMNI-M-UT-*n*C**

<b>Frequency</b>	
Effective digitizing frequency	Up to 100 MHz (10 bits)
A-scan (acquisition mode)	Up to 6000 A-scans per second (512-point, 8-bit A-scan)
Maximum pulsing rate	Up to 10 kHz (C-scan)
Depth in material	59.8 meters in steel (L-wave), 10 ms with compression 0.49 meter in steel (L-wave), 81.9 $\mu$ s without compression
<b>Display</b>	
Refresh rate	A-scan: 60 Hz
Envelope (echo-dynamic mode)	Yes
<b>Synchronization</b>	
On internal clock	1 Hz to 10 kHz
External pace	Yes
On encoder	On 2 axes: from 1 to 65536 steps

## D.3 Data Specifications

This section outlines the data specifications for processing, TCG, and storage (Table 37 on page 147).

**Table 37 Data specifications – OMNI-M-UT-*n*C**

<b>Processing</b>	
Number of data points	Up to 8000
Real-time averaging	2, 4, 8, 16
Rectification	RF, full wave, half wave+, half wave-

**Table 37 Data specifications – OMNI-M-UT-nC (continued)**

Video filtering	Smoothing (adjusted to probe frequency range)
Filtering	Centered at: 1 MHz 2 MHz 5 MHz 10 MHz 15 MHz 20 MHz
	Band-pass filter: 0.25 MHz to 2.25 MHz $\pm 10\%$ 2 MHz to 25 MHz $\pm 10\%$
<b>Programmable TCG</b>	
Number of points	16: One TCG (time-corrected gain) curve per channel
Maximum gain	40 dB
Maximum slope	20 dB/ $\mu$ s
Step	0.1 dB
Synchronization	Pulser or gate I
<b>Storage</b>	
A-scan recording (TOFD)	6000 A-scans per second (512-point, 8-bit A-scan)
C-scan recording	I, A, B, up to 10 kHz
Maximum file size	Limited to available internal flash memory: OmniScan MX / MX1: 180 MB (or 300 MB optional) OmniScan MX2: 300 MB

---

## Appendix E: OMNI-M-PA1616M and OMNI-M-PA1664M Module Specifications

---



### CAUTION

To reduce the risk of electric shock, avoid touching the inner conductor of the BNC (or LEMO) connectors. Up to 200 V can be present on the inner conductor. The warning symbol near the BNC connectors signals this electric shock risk.

---

### IMPORTANT

The OMNI-M-PA1616M module is compatible with the OmniScan MX only.

---

This appendix outlines the technical specifications for OmniScan PA acquisition module models OMNI-M-PA1616M and OMNI-M-PA1664M (Figure E-1 on page 150).

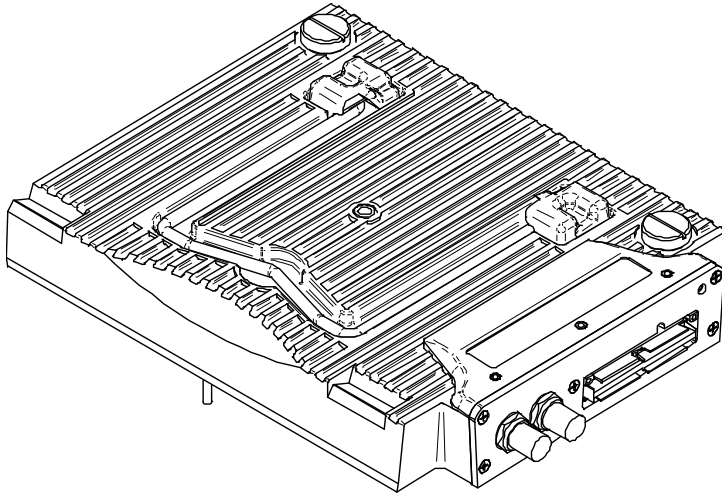

**Figure E-1 Phased array module models OMNI-M-PA1616M and OMNI-M-PA1664M**

## E.1 Acoustic Specifications

This section lists the acoustic specifications for the pulser, receiver, and beam formation (Table 38 on page 150).

**Table 38 Acoustic specifications — OMNI-M-PA16mmM**

<b>Pulser</b>	
Voltage	Low: 40 V High: 80 V
Pulse width	Adjustable from 30 ns to 500 ns; resolution of 2.5 ns
Fall time	<10 ns
Pulse shape	Negative square pulse
Output impedance	<25 $\Omega$
<b>Receiver</b>	
Gain range	0 dB to 74 dB, maximum input signal 1.32 V <sub>p-p</sub>
Input impedance	75 $\Omega$

**Table 38 Acoustic specifications – OMNI-M-PA16mmM (continued)**

System bandwidth	0.75 MHz to 18 MHz (-3 dB)
<b>Beam formation</b>	
Scan type	Sectorial and linear
Aperture	16 elements
Number of elements	16 elements for the OMNI-M-PA1616M 64 elements for the OMNI-M-PA1664M
Number of focal laws	128
Delay range transmission	0 $\mu$ s to 10 $\mu$ s in 2.5 ns increments
Delay range reception	0 $\mu$ s to 10 $\mu$ s in 2.5 ns increments

## E.2 Acquisition Specifications

This section details the acquisition specifications of frequency, data display, and synchronization (Table 39 on page 151).

**Table 39 Acquisition specifications – OMNI-M-PA16mmM**

<b>Frequency</b>	
Effective digitizing frequency	Up to 100 MHz (10 bits)
Maximum pulsing rate	Up to 10 kHz (C-scan)
<b>Display</b>	
Refresh rate	A-scan: 60 Hz; S-scan: up to 40 Hz
Envelope (echo-dynamic mode)	Yes: Volume-corrected S-scan (up to 40 Hz)
<b>Synchronization</b>	
On internal clock	1 Hz to 10 kHz

## E.3 Data Specifications

This section details the data specifications of processing and TCG (Table 40 on page 152).

**Table 40 Data specifications – OMNI-M-PA16mmM**

<b>Processing</b>	
Real-time averaging	2, 4, 8, and 16
Rectification	RF, full wave, half wave+, half wave-
Filtering	Low-pass (adjusted to probe frequency), digital filtering (bandwidth, frequency range).
Video filtering	Smoothing (adjusted to the probe frequency range).
<b>Programmable TCG</b>	
Number of points	16: One TCG (time-corrected gain) curve per channel for focal laws.
<b>Storage</b>	
C-scan recording	I, A, B, up to 10 kHz
Maximum file size	Limited to available internal flash memory: OmniScan MX / MX1: 180 MB (or 300 MB optional). OmniScan MX2: 300 MB



---

## Appendix F: OMNI-M-PA1616 Module Specifications

---



### CAUTION

Avoid touching the inner conductor of the BNC (or LEMO) connectors to reduce the risk of electric shock. Up to 200 V can be present on the inner conductor. The warning symbol near the BNC connectors signals this electric shock risk.

---

### IMPORTANT

The OMNI-M-PA1616 module is compatible with the OmniScan MX only.

---

This appendix lists the technical specifications for OmniScan PA acquisition module model OMNI-M-PA1616 (Figure F-1 on page 154).

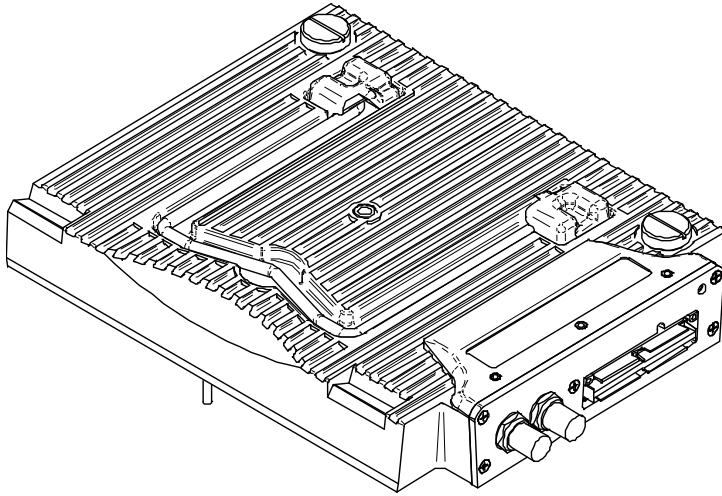

Figure F-1 Phased array module model OMNI-M-PA1616

## F.1 Acoustic Specifications

This section details the acoustic specifications of the pulser, receiver, and beam formation (Table 41 on page 154).

Table 41 Acoustic specifications— OMNI-M-PA1616

<b>Pulser</b>	
Voltage	Low: 40 V High: 80 V
Pulse width	Adjustable from 30 ns to 500 ns; resolution of 2.5 ns
Fall time	<10 ns
Pulse shape	Negative square pulse
Output impedance	<25 $\Omega$
<b>Receiver</b>	
Gain range	0 dB to 74 dB maximum input signal 1.32 V <sub>p-p</sub>
Input impedance	75 $\Omega$
System bandwidth	0.75 MHz to 18 MHz (-3 dB)

**Table 41 Acoustic specifications— OMNI-M-PA1616 (continued)**

<b>Beam formation</b>	
Scan type	Sectorial and linear
Aperture	16 elements
Number of elements	16 elements
Number of focal laws	256
Delay range transmission	0 $\mu$ s to 10 $\mu$ s in 2.5 ns increments
Delay range reception	0 $\mu$ s to 10 $\mu$ s in 2.5 ns increments

## F.2 Acquisition Specifications

This section details the acquisition specifications of frequency, data display, and synchronization (Table 42 on page 155).

**Table 42 Acquisition specifications – OMNI-M-PA1616**

<b>Frequency</b>	
Effective digitizing frequency	Up to 100 MHz (10 bits)
A-scan (acquisition mode)	Up to 6000 A-scans per second (512-point, 8-bit A-scan)
Maximum pulsing rate	Up to 10 kHz (C-scan)
Depth in material	59.8 meters in steel (longitudinal wave), 10 ms with compression 0.49 meter in steel (longitudinal wave), 81.9 $\mu$ s without compression
<b>Display</b>	
Refresh rate	A-scan: 60 Hz; S-scan: 20 Hz to 30 Hz
Envelope (echo-dynamic mode)	Yes: Volume-corrected S-scan (30 Hz)
<b>Synchronization</b>	
On internal clock	1 Hz to 10 kHz
External pace	Yes
On encoder	On 2 axes: from 1 to 65536 steps.

## F.3 Data Specifications

This section details the data specifications of processing, TCG, and storage (Table 43 on page 156).

**Table 43 Data specifications — OMNI-M-PA1616**

<b>Processing</b>	
Number of data points	Up to 8000
Real-time averaging	2, 4, 8, and 16
Rectification	RF, full wave, half wave+, half wave-
Filtering	Low-pass (adjusted to probe frequency), digital filtering (bandwidth, frequency range)
Video filtering	Smoothing (adjusted to the probe frequency range)
<b>Programmable TCG</b>	
Number of points	16: one TCG (time-corrected gain) curve per channel for focal laws
<b>Storage</b>	
A-scan recording	6000 A-scans per second (512-point, 8-bit A-scan)
C-scan recording	I, A, B, up to 10 kHz
Maximum file size	Limited to available internal flash memory: OmniScan MX / MX1: 180 MB (or 300 MB optional) OmniScan MX2: 300 MB

---

## Appendix G: OMNI-M-PA16128 Module Specifications

---



### CAUTION

To reduce the risk of electric shock, avoid touching the inner conductor of the BNC (or LEMO) connectors. Up to 200 V can be present on the inner conductor. The warning symbol near the BNC connectors signals this electric shock risk.

---

This appendix lists the technical specifications for OmniScan PA acquisition module model OMNI-M-PA16128 (Figure G-1 on page 157).

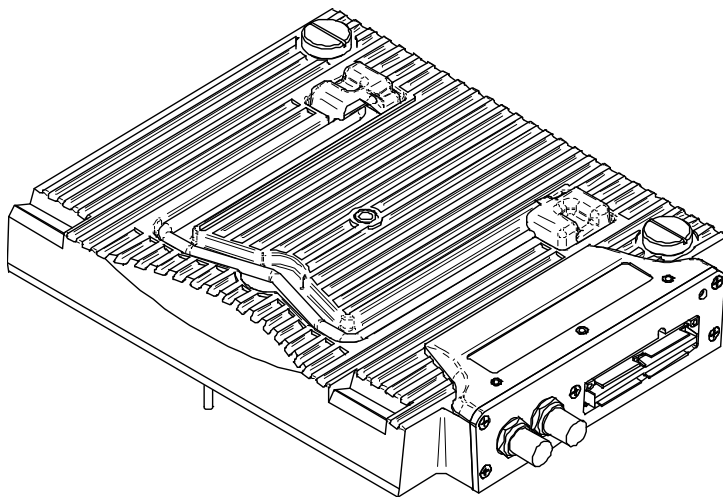

**Figure G-1** Phased array module model OMNI-M-PA16128

## G.1 Acoustic Specifications

This section details the acoustic specifications of the pulser, receiver, and beam formation (Table 44 on page 158).

**Table 44 Acoustic specifications — OMNI-M-PA16128**

<b>Pulser</b>	
Voltage	Low: 40 V High: 80 V
Pulse width	Adjustable from 30 ns to 500 ns; resolution of 2.5 ns
Fall time	<10 ns
Pulse shape	Negative square pulse
Output impedance	<25 $\Omega$
<b>Receiver</b>	
Gain range	0 dB to 74 dB maximum input signal 1.32 V <sub>p-p</sub>
Input impedance	75 $\Omega$
System bandwidth	0.75 MHz to 18 MHz (-3 dB)
<b>Beam formation</b>	
Scan type	Sectorial and linear
Aperture	16 elements
Number of elements	128 elements
Number of focal laws	256
Delay range transmission	0 $\mu$ s to 10 $\mu$ s in 2.5 ns increments
Delay range reception	0 $\mu$ s to 10 $\mu$ s in 2.5 ns increments

## G.2 Acquisition Specifications

This section lists the acquisition specifications for frequency, data display, and synchronization (Table 45 on page 159).

**Table 45 Acquisition specifications – OMNI-M-PA16128**

<b>Frequency</b>	
Effective digitizing frequency	Up to 100 MHz (10 bits)
A-scan (acquisition mode)	Up to 6000 A-scans per second (512-point, 8-bit A-scan)
Maximum pulsing rate	Up to 10 kHz (C-scan)
Depth in material	59.8 meters in steel (longitudinal wave), 10 ms with compression 0.49 meter in steel (longitudinal wave), 81.9 $\mu$ s without compression
<b>Display</b>	
Refresh rate	A-scan: 60 Hz; S-scan: 20 Hz to 30 Hz
Envelope (echo-dynamic mode)	Yes: Volume-corrected S-scan (30 Hz)
<b>Synchronization</b>	
On internal clock	1 Hz to 10 kHz
External pace	Yes
On encoder	On 2 axes: from 1 to 65536 steps

## G.3 Data Specifications

This section details the data specifications of processing, TCG, and storage (Table 46 on page 159).

**Table 46 Data specifications – OMNI-M-PA16128**

<b>Processing</b>	
Number of data points	Up to 8000
Real-time averaging	2, 4, 8, and 16
Rectification	RF, full wave, half wave+, half wave-

**Table 46 Data specifications – OMNI-M-PA16128 (continued)**

Filtering	Low-pass (adjusted to probe frequency), digital filtering (bandwidth, frequency range)
Video filtering	Smoothing (adjusted to the probe frequency range)
<b>Programmable TCG</b>	
Number of points	16: One TCG (time-corrected gain) curve per channel for focal laws
<b>Storage</b>	
A-scan recording	6000 A-scans per second (512-point, 8-bit A-scan)
C-scan recording	I, A, B, up to 10 kHz
Maximum file size	Limited to available internal flash memory: OmniScan MX / MX1: 180 MB (or 300 MB optional) OmniScan MX2: 300 MB



---

## Appendix H: OMNI-M-PA16128PR Module Specifications

---



### CAUTION

To reduce the risk of electric shock, avoid touching the inner conductor of the BNC (or LEMO) connectors. Up to 200 V can be present on the inner conductor. The warning symbol near the BNC connectors signals this electric shock risk.

---

### IMPORTANT

The OMNI-M-PA16128PR module is compatible with the OmniScan MX only.

---

This appendix lists the technical specifications for OmniScan PA acquisition module model OMNI-M-PA16128PR (Figure H-1 on page 162).

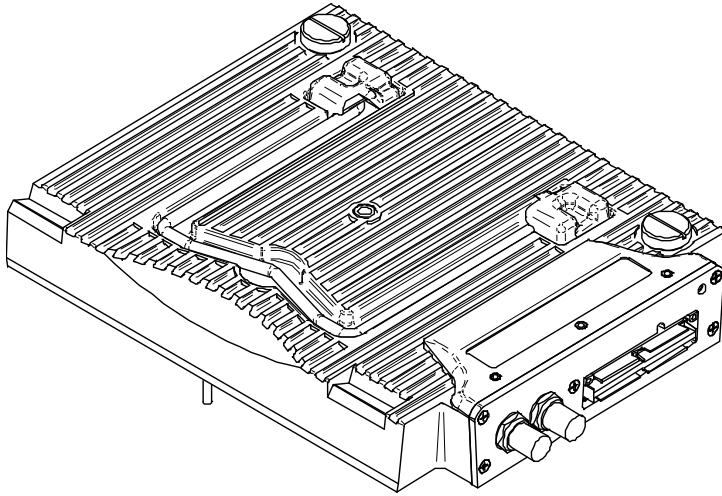

**Figure H-1 Phased array module model OMNI-M-PA16128PR**

## H.1 Acoustic Specifications

This section lists the acoustic specifications for the pulser, receiver, and beam formation (Table 47 on page 162).

**Table 47 Acoustic specifications — OMNI-M-PA16128PR**

<b>Pulser</b>	
Voltage	Low: 40 V High: 80 V
Pulse width	Adjustable from 30 ns to 500 ns; resolution of 2.5 ns
Fall time	<10 ns
Pulse shape	Negative square pulse
Output impedance	<25 $\Omega$
<b>Receiver</b>	
Gain range	0 dB to 74 dB maximum input signal 1.32 V <sub>p-p</sub>
Input impedance	50 $\Omega$ (pulse-echo channel) 150 $\Omega$ (pitch-catch channel)

**Table 47 Acoustic specifications — OMNI-M-PA16128PR (continued)**

System bandwidth	0.75 MHz to 18 MHz (-3 dB)
<b>Beam formation</b>	
Scan type	Sectorial and linear
Aperture	16 elements
Number of elements	128 elements
Number of focal laws	256
Delay range transmission	0 $\mu$ s to 10 $\mu$ s in 2.5 ns increments
Delay range reception	0 $\mu$ s to 10 $\mu$ s in 2.5 ns increments

## H.2 Acquisition Specifications

This section details the acquisition specifications of frequency, data display, and synchronization (Table 48 on page 163).

**Table 48 Acquisition specifications — OMNI-M-PA16128PR**

<b>Frequency</b>	
Effective digitizing frequency	Up to 100 MHz (10 bits)
A-scan (acquisition mode)	Up to 6000 A-scans per second (512-point, 8-bit A-scan)
Maximum pulsing rate	Up to 10 kHz (C-scan).
Depth in material	59.8 meters in steel (longitudinal wave), 10 ms with compression 0.49 meter in steel (longitudinal wave), 81.9 $\mu$ s without compression
<b>Display</b>	
Refresh rate	A-scan: 60 Hz; S-scan: 20 Hz to 30 Hz
Envelope (echo-dynamic mode)	Yes: Volume-corrected S-scan (30 Hz)
<b>Synchronization</b>	
On internal clock	1 Hz to 10 kHz
External pace	Yes
On encoder	On 2 axes: from 1 to 65536 steps

## H.3 Data Specifications

This section details the data specifications of processing, TCG, and storage (Table 49 on page 164).

**Table 49 Data specifications – OMNI-M-PA16128PR**

<b>Processing</b>	
Number of data points	Up to 8000
Real-time averaging	2, 4, 8, and 16
Rectification	RF, full wave, half wave+, half wave-
Filtering	Low-pass (adjusted to probe frequency), digital filtering (bandwidth, frequency range).
Video filtering	N/A
<b>Programmable TCG</b>	
Number of points	16: One TCG (time-corrected gain) curve per channel for focal laws
<b>Storage</b>	
A-scan recording	6000 A-scans per second (512-point, 8-bit A-scan)
C-scan recording	I, A, B, up to 10 kHz
Maximum file size	Limited to available internal flash memory: OmniScan MX / MX1: 180 MB (or 300 MB optional) OmniScan MX2: 300 MB

---

## Appendix I: OMNI-M-PA32128PR Module Specifications

---

This appendix presents the technical specifications for OmniScan PA acquisition module model OMNI-M-PA32128PR (Figure I-1 on page 165).

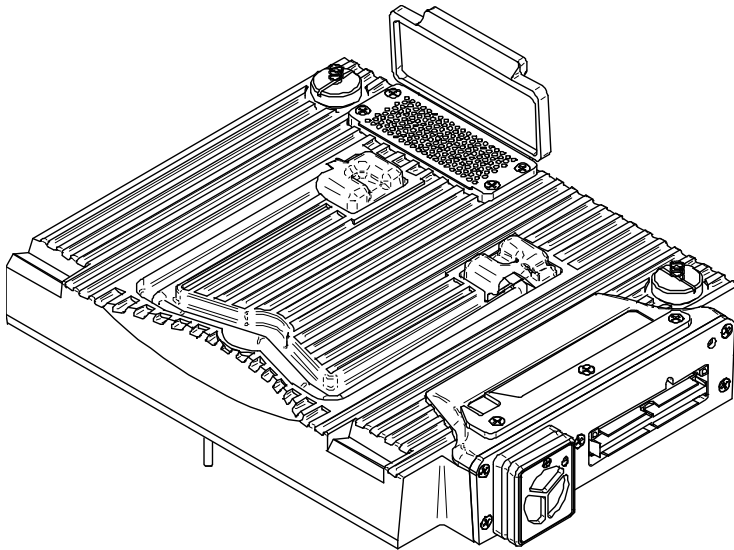

**Figure I-1** Phased array module model OMNI-M-PA32128PR

## I.1 Acoustic Specifications

This section lists the acoustic specifications for the pulser, receiver, and beam formation (Table 50 on page 166).

**Table 50 Acoustic specifications — OMNI-M-PA32128PR**

<b>Pulser</b>	
Voltage	Low: 45 V High: 90 V
Pulse width	Adjustable from 30 ns to 500 ns; resolution of 2.5 ns
Fall time	<5 ns
Pulse shape	Negative square pulse
Output impedance	<30 $\Omega$
<b>Receiver</b>	
Gain range	0 dB to 74 dB in steps of 0.1 dB, maximum input signal 1.3 V <sub>p-p</sub> (pulse-echo channel) and 0.9 V <sub>p-p</sub> (pitch-catch channel)
Input impedance	50 $\Omega$ (pulse-echo channel) and 150 $\Omega$ (pitch-catch channel)
System bandwidth	0.53 MHz to 21 MHz, $\pm 10$ % ( $-3$ dB)
<b>Beam formation</b>	
Scan type	Sectorial and linear
Aperture	32 elements
Number of elements	128 elements
Number of focal laws	256
Delay range transmission	0 $\mu$ s to 10 $\mu$ s in 2.5 ns increments
Delay range reception	0 $\mu$ s to 10 $\mu$ s in 2.5 ns increments

## I.2 Acquisition Specifications

This section lists the acquisition specifications for frequency, data display, and synchronization (Table 51 on page 167).

**Table 51 Acquisition specifications – OMNI-M-PA32128PR**

<b>Frequency</b>	
Effective digitizing frequency	Up to 100 MHz (10 bits)
A-scan (acquisition mode)	Up to 6000 A-scans per second (512-point, 8-bit A-scan)
Maximum pulsing rate	Up to 10 kHz (C-scan)
Depth in material	59.8 meters in steel (longitudinal wave), 10 ms with compression 0.49 meter in steel (longitudinal wave), 81.9 $\mu$ s without compression
<b>Display</b>	
Refresh rate	A-scan: 60 Hz; S-scan: 20 Hz to 30 Hz
Envelope (echo-dynamic mode)	Yes: Volume-corrected S-scan (30 Hz)
<b>Synchronization</b>	
On internal clock	1 Hz to 10 kHz
External pace	Yes
On encoder	On 2 axes: from 1 step to 65536 steps

## I.3 Data Specifications

This section details the data specifications of processing, TCG, and storage (Table 52 on page 167).

**Table 52 Data specifications – OMNI-M-PA32128PR**

<b>Processing</b>	
Number of data points	Up to 8000
Real-time averaging	2, 4, 8, and 16
Rectification	RF, full wave, half wave+, half wave-

**Table 52 Data specifications – OMNI-M-PA32128PR (continued)**

Filtering	Low-pass (adjusted to probe frequency), digital filtering (bandwidth, frequency range)
Video filtering	Smoothing (adjusted to the probe frequency range)
<b>Programmable TCG</b>	
Number of points	16: One TCG (time-corrected gain) curve per channel for focal laws
<b>Storage</b>	
A-scan recording	6000 A-scans per second (512-point, 8-bit A-scan)
C-scan recording	I, A, B, up to 10 kHz
Maximum file size	Limited to available internal flash memory: OmniScan MX / MX1: 180 MB (or 300 MB optional) OmniScan MX2: 300 MB



## Appendix J: OMNI-M-PA3232 Module Specifications

---

This appendix lists the technical specifications for OmniScan PA acquisition module model OMNI-M-PA3232 (Figure J-1 on page 169).

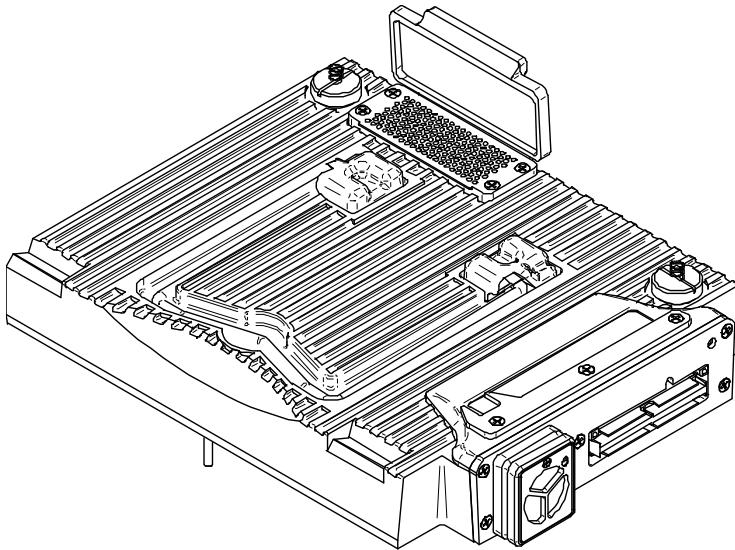

**Figure J-1** Phased array module model OMNI-M-PA3232

## J.1 Acoustic Specifications

This section details the acoustic specifications of the pulser, receiver, and beam formation (Table 53 on page 170).

**Table 53 Acoustic specifications – OMNI-M-PA3232**

<b>Pulser</b>	
Voltage	Low: 50 V Medium: 100 V High: 200 V
Pulse width	Adjustable from 30 ns to 500 ns; resolution of 2.5 ns
Fall time	<5 ns
Pulse shape	Negative square pulse
Output impedance	<30 $\Omega$
<b>Receiver</b>	
Gain range	0 dB to 74 dB in steps of 0.1 dB, maximum input signal 1.1 V <sub>p-p</sub>
Input impedance	50 $\Omega$
System bandwidth	0.53 MHz to 23 MHz, $\pm 10\%$ ( $-3$ dB)
<b>Beam formation</b>	
Scan type	Sectorial and linear
Aperture	32 elements
Number of elements	32 elements
Number of focal laws	256
Delay range transmission	0 $\mu$ s to 10 $\mu$ s in 2.5 ns increments
Delay range reception	0 $\mu$ s to 10 $\mu$ s in 2.5 ns increments

## J.2 Acquisition Specifications

This section details the acquisition specifications of frequency, data display, and synchronization (Table 54 on page 171).

**Table 54 Acquisition specifications – OMNI-M-PA3232**

<b>Frequency</b>	
Effective digitizing frequency	Up to 100 MHz (10 bits)
A-scan (acquisition mode)	Up to 6000 A-scans per second (512-point, 8-bit A-scan)
Maximum pulsing rate	Up to 10 kHz (C-scan)
Depth in material	59.8 meters in steel (longitudinal wave), 10 ms with compression 0.49 meter in steel (longitudinal wave), 81.9 $\mu$ s without compression
<b>Display</b>	
Refresh rate	A-scan: 60 Hz; S-scan: 20 Hz to 30 Hz
Envelope (echo-dynamic mode)	Yes: Volume-corrected S-scan (30 Hz)
<b>Synchronization</b>	
On internal clock	1 Hz to 10 kHz
External pace	Yes
On encoder	On 2 axes: from 1 step to 65536 steps

## J.3 Data Specifications

This section details the data specifications of processing, TCG, and storage (Table 55 on page 171).

**Table 55 Data specifications – OMNI-M-PA3232**

<b>Processing</b>	
Number of data points	Up to 8000
Real-time averaging	2, 4, 8, and 16
Rectification	RF, full wave, half wave+, half wave-

**Table 55 Data specifications – OMNI-M-PA3232 (continued)**

Filtering	Low-pass (adjusted to probe frequency), digital filtering (bandwidth, frequency range)
Video filtering	Smoothing (adjusted to the probe frequency range)
<b>Programmable TCG</b>	
Number of points	16: One TCG (time-corrected gain) curve per channel for focal laws
<b>Storage</b>	
A-scan recording	6000 A-scans per second (512-point, 8-bit A-scan)
C-scan recording	I, A, B, up to 10 kHz
Maximum file size	Limited to available internal flash memory: OmniScan MX / MX1: 180 MB (or 300 MB optional) OmniScan MX2: 300 MB

---

## Appendix K: OMNI-M-PA1664 Module Specifications

---



### CAUTION

To reduce the risk of electric shock, avoid touching the inner conductor of the BNC (or LEMO) connectors. Up to 200 V can be present on the inner conductor. The warning symbol near the BNC connectors signals this electric shock risk.

---

### IMPORTANT

The OMNI-M-PA1664 module is compatible with the OmniScan MX2 only.

---

This appendix lists the technical specifications for OmniScan PA acquisition module model OMNI-M-PA1664 (Figure K-1 on page 174).

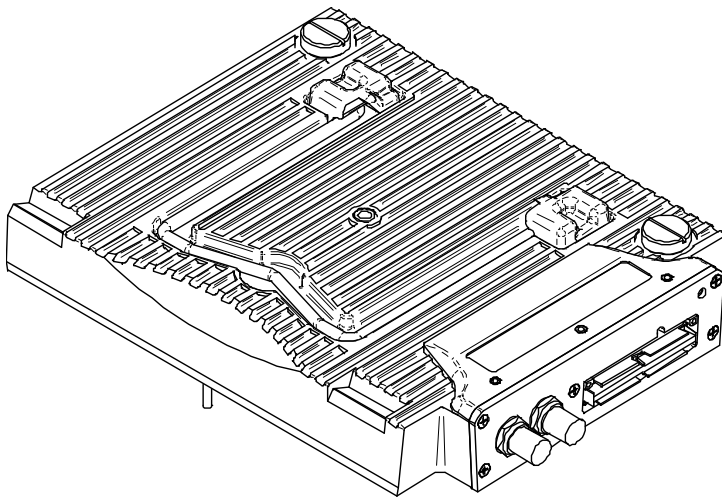

Figure K-1 Phased array module model OMNI-M-PA1664

## K.1 Acoustic Specifications

This section details the acoustic specifications of the pulser, receiver, and beam formation (Table 56 on page 174).

Table 56 Acoustic specifications — OMNI-M-PA1664

<b>Pulser</b>	
Voltage	Low: 40 V High: 80 V
Pulse width	Adjustable from 30 ns to 500 ns; resolution of 2.5 ns
Fall time	<10 ns
Pulse shape	Negative square pulse
Output impedance	<25 $\Omega$
<b>Receiver</b>	
Gain range	0 dB to 74 dB maximum input signal 1.32 V <sub>p-p</sub>
Input impedance	75 $\Omega$
System bandwidth	0.75 MHz to 18 MHz (-3 dB)

**Table 56 Acoustic specifications – OMNI-M-PA1664 (continued)**

<b>Beam formation</b>	
Scan type	Sectorial and linear
Aperture	16 elements
Number of elements	64 elements
Number of focal laws	256
Delay range transmission	0 $\mu$ s to 10 $\mu$ s in 2.5 ns increments
Delay range reception	0 $\mu$ s to 10 $\mu$ s in 2.5 ns increments

## K.2 Acquisition Specifications

This section lists the acquisition specifications for frequency, data display, and synchronization (Table 57 on page 175).

**Table 57 Acquisition specifications – OMNI-M-PA1664**

<b>Frequency</b>	
Effective digitizing frequency	Up to 100 MHz (10 bits)
A-scan (acquisition mode)	Up to 6000 A-scans per second (512-point, 8-bit A-scan)
Maximum pulsing rate	Up to 10 kHz (C-scan)
Depth in material	59.8 meters in steel (longitudinal wave), 10 ms with compression 0.49 meter in steel (longitudinal wave), 81.9 $\mu$ s without compression
<b>Display</b>	
Refresh rate	A-scan: 60 Hz; S-scan: 20 Hz to 30 Hz
Envelope (echo-dynamic mode)	Yes: Volume-corrected S-scan (30 Hz)
<b>Synchronization</b>	
On internal clock	1 Hz to 10 kHz
External pace	Yes
On encoder	On 2 axes: from 1 to 65536 steps

## K.3 Data Specifications

This section details the data specifications of processing, TCG, and storage (Table 58 on page 176).

**Table 58 Data specifications – OMNI-M-PA1664**

<b>Processing</b>	
Number of data points	Up to 8000
Real-time averaging	2, 4, 8, and 16
Rectification	RF, full wave, half wave+, half wave-
Filtering	Low-pass (adjusted to probe frequency), digital filtering (bandwidth, frequency range)
Video filtering	Smoothing (adjusted to the probe frequency range)
<b>Programmable TCG</b>	
Number of points	16: One TCG (time-corrected gain) curve per channel for focal laws
<b>Storage</b>	
A-scan recording	6000 A-scans per second (512-point, 8-bit A-scan)
C-scan recording	I, A, B, up to 10 kHz
Maximum file size	Limited to available internal flash memory: 300 MB



---

## Appendix L: OMNI-M-ECA4-32 and OMNI-M1-ECA4-32 Module Specifications

---

---

<b>IMPORTANT</b>
------------------

The OMNI-M-ECA4-32 module and OMNI-M1-ECA4-32 module are compatible with the OmniScan MX / MX1 only. For more details about standards compliance and compatibility of these modules, see “Available and Discontinued Products” on page 77 and “Compatibility Tables” on page 129.

---

This appendix presents eddy current array (ECA) acquisition module model OMNI-M-ECA4-32 and OMNI-M1-ECA4-32, which can be used with the OmniScan MX / MX1 unit.

### L.1 ECA Acquisition Module Description

The ECA acquisition module (Figure L-1 on page 178) is designed for durability and simplicity. You can use the module to perform eddy current array or conventional eddy current inspections.

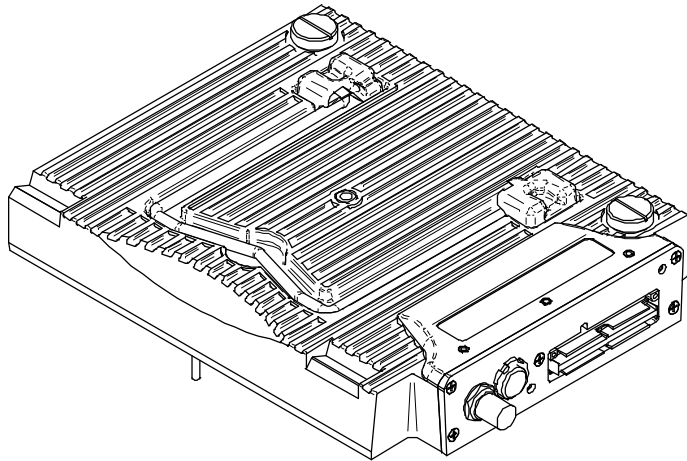

**Figure L-1 OMNI-M-ECA4-32 and OMNI-M1-ECA4-32 acquisition module**

## **L.2 ECA Acquisition Module Receptacles**

The ECA acquisition module is equipped with three receptacles on the left side:

### **1CH**

BNC receptacle for one single-coil eddy current probe using conventional eddy current technique.

### **4CH**

A 19-pin receptacle used for eddy current probes with up to four single coils.

### **EC ARRAY**

Evident receptacle used for the eddy current array inspection technique.

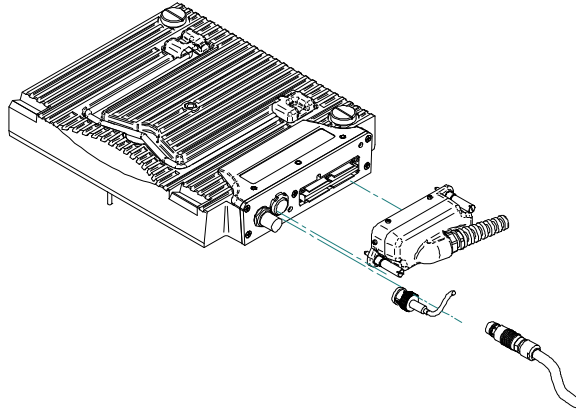

**Figure L-2 ECA module with connectors**

### **To connect the ECA probe connector**

1. Align the ECA probe connector correctly by matching its guide pins with the EC ARRAY module receptacle (Figure L-2 on page 179).
2. Gently press the ECA probe connector into the EC ARRAY module receptacle until completely inserted and maintain pressure on the probe connector.
3. Tighten the retaining screws located on each side of the ECA probe connector.

## **L.3 Probe Connectors**

The probes can be connected to the eddy current array module using three types of connectors.

- The first type is the Evident ECA probe connector (Figure L-3 on page 180).

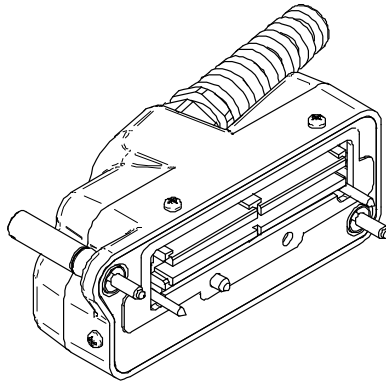

**Figure L-3 Evident ECA probe connector**

- The second type is a 19-pin connector (Figure L-4 on page 180) used in multiple-coil eddy current technology probes.

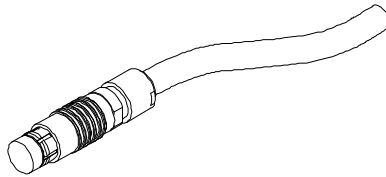

**Figure L-4 19-pin eddy current probe connector**

The references for this connector are found in “4CH Connector References” on page 181.

- The third type is a BNC connector (Figure L-5 on page 180), used in certain single-coil eddy current technology probes.

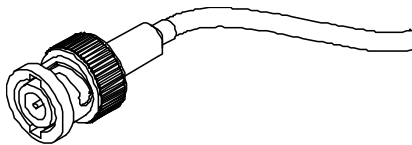

**Figure L-5 Eddy current probe BNC connector**

## L.4 4CH Connector References

### Description

19-pin connector

### Manufacturer, number

Fischer, 1031-A019-130

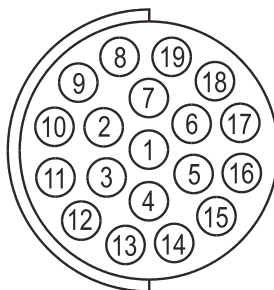

Figure L-6 4CH connector

Table 59 Pinout for the 4CH connector [OMNI-M-ECA4-32 and OMNI-M1-ECA4-32 modules]

Pin	Signal	Description	Current
1	PROBEDATA_P	Probe ID Data	
2	GEN50_1	Main generator 50/100 $\Omega$ Termination #1	
3	HSWAP1	Automatic probe detection	
4	ANGD	Ground	
5	ANGD	Ground	
6	ANGD	Ground	
7	GEN50_2	Main generator 50/100 $\Omega$ Termination #2	
8	GEN0°	Main generator #1 direct output	

**Table 59 Pinout for the 4CH connector [OMNI-M-ECA4-32 and OMNI-M1-ECA4-32 modules] (continued)**

Pin	Signal	Description	Current
9	GEN180°	Main generator #2 direct output	
10	-VDC_DRV_P	External MUX power supply -8/-10 V	500 mA
11	IN1+	Input 1 positive	
12	IN1-	Input 1 negative	
13	IN2+	Input 2 positive	
14	IN2-	Input 2 negative	
15	IN3+	Input 3 positive	
16	IN3-	Input 3 negative	
17	IN4+	Input 4 positive	
18	IN4-	Input 4 negative	
19	+VDC_DRV_P	External MUX power supply +8/+10 V	500 mA

## L.5 ECA Acquisition Module Specifications

This section covers the ECA acquisition module specifications, and includes the general specifications for the module, in addition to the specifications applicable to the multiplexer and data parameters.

## L.5.1 General Specifications

**Table 60 General specifications — OMNI-M-ECA4-3 and OMNI-M1-ECA4-32 modules**

Receptacles	1 Evident eddy current array probe receptacle
	1 19-pin Fischer eddy current probe receptacle
	1 BNC receptacle
Number of channels	1 to 64

## L.5.2 Generator and Receiver

**Table 61 Generator and receiver specifications — OMNI-M-ECA4-32 and OMNI-M1-ECA4-32**

<b>Channels</b>	
Number of channels	32 channels with internal multiplexer 64 channels with external multiplexer
<b>Generator</b>	
Number of generators	2 (Gen. 2 used as internal reference)
Supported voltage	12 Vp-p
Operational frequency	20 Hz to 6 MHz
Bandwidth	8 Hz to 5 KHz (single coil); inversely proportional to the time slot duration and set by the instrument (multiplexed)
Maximum load	10 $\Omega$
<b>Receiver</b>	
Number of receivers	1 to 4
Operation frequency	20 Hz to 6 MHz
Maximum input signal	1 Vp-p (minimum gain)
Maximum balance offset	266 mVp-p
Gain	With analog gain, 28 dB fixed and 40 dB adjustable With digital gain, 22 dB to 98 dB

**Table 61 Generator and receiver specifications — OMNI-M-ECA4-32 and OMNI-M1-ECA4-32 (continued)**

<b>Internal multiplexer</b>	
Number of generators	32 (4 simultaneously on 8 time slots)
Maximum amplitude	12 Vp-p
Maximum load	50 $\Omega$
Number of receivers	4 differential receivers (8 time slots each)
Maximum input signal	1 Vp-p

### L.5.3 Data

**Table 62 Data specifications — OMNI-M-ECA4-32 and OMNI-M1-ECA4-32**

<b>Data acquisition</b>	
Digitizing frequency	40 MHz
Acquisition rate	1 Hz to 20 kHz (single coil) The rate can be limited by the instrument's processing capabilities, or by delays set by the multiplexed excitation mode.
Analog/digital resolution	16 bits
<b>Data processing</b>	
Phase rotation	0° to 360° with increments of 0.1°
Filtering	FIR low-pass (adjustable cutoff frequency)
	FIR high-pass (adjustable cutoff frequency)
	FIR band-pass (adjustable cutoff frequency)
	FIR band-stop (adjustable cutoff frequency)
	Median filter (variable from 2 points to 200 points)
	Mean filter (variable from 2 points to 200 points)
Channel processing	Mixing Merging Interpolation
<b>Data storage</b>	



**Table 62 Data specifications – OMNI-M-ECA4-32 and OMNI-M1-ECA4-32**

Maximum file size	Limited to available internal flash memory: 180 MB (or 300 MB optional)
<b>Data synchronization</b>	
On internal clock	1 Hz to 20 kHz (single coil)
External pace	Yes
On 1 axis or 2 axes	Yes
<b>Alarms</b>	
Number of alarm outputs	3
Outputs	Visual, audio, and TTL signal



---

## Appendix M: OMNI-M2-PA1664/16128/32128/32128PR Module Specifications

---



### CAUTION

- To reduce the risk of electric shock, avoid touching the inner conductor of the LEMO connectors. Up to 340 V can be present on the inner conductor of the UT connectors, and up to 115 V can be present on the PA connector. The warning symbol near the LEMO connectors signals this electric shock risk (Figure M-1 on page 187).
  - Reinforced insulation must be provided for the probes connected to the module.
- 

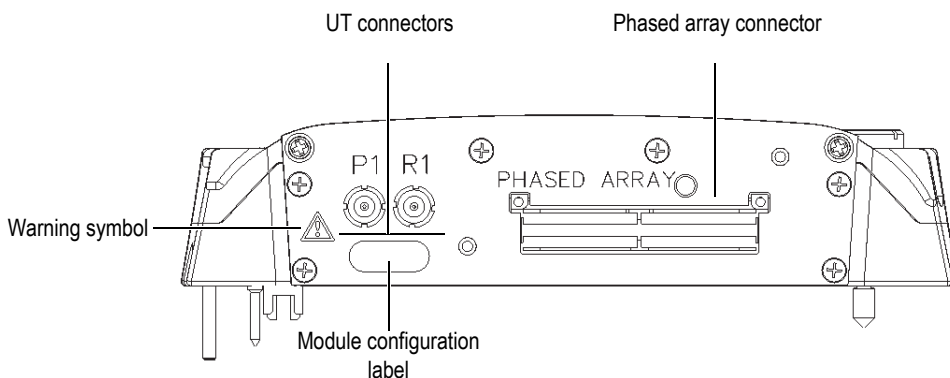

**Figure M-1** Module side view

This appendix lists the technical specifications for OmniScan PA acquisition module models OMNI-M2-PA1664, OMNI-M2-PA16128, OMNI-M2-PA32128 and OMNI-M2-PA32128PR (Figure M-2 on page 188).

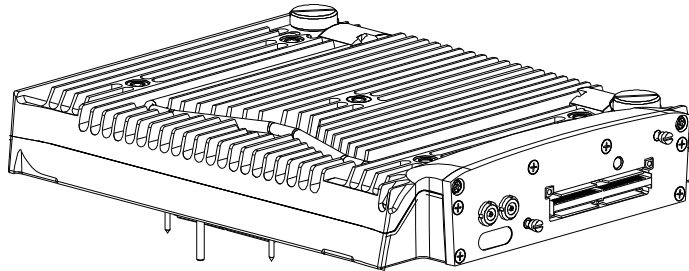

**Figure M-2 Phased array module model OMNI-M2-PA1664/16128/32128/32128PR**

By default, these acquisition modules come with an anchor base (Figure M-3 on page 188), which allows the usage of EZ Latch probe connectors.

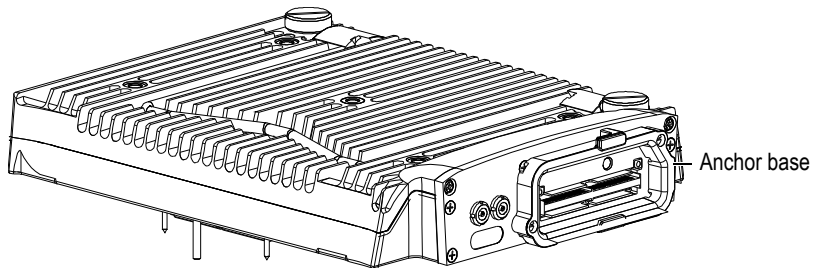

**Figure M-3 Module with anchor base**

A PA connector cap is attached to the anchor base (Figure M-4 on page 189). When the UT channel is the only channel used, place this cap over the PA connector to protect it against dirt and water.

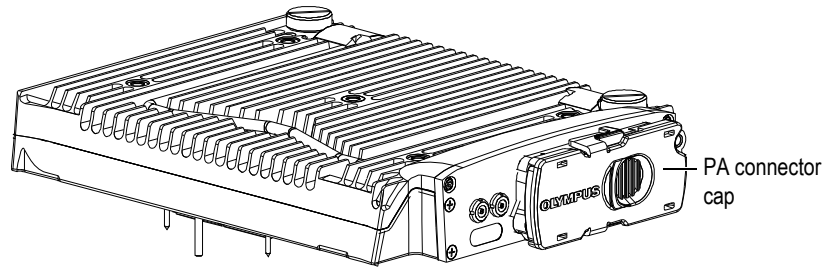

**Figure M-4 Module with PA connector cap**

---

**NOTE**

Before using a phased array probe that is not equipped with an EZ Latch connector, remove the anchor base, which is secured by two screws.

---

You can also attach accessories to these acquisition modules using the fastening holes (Figure M-5 on page 190).

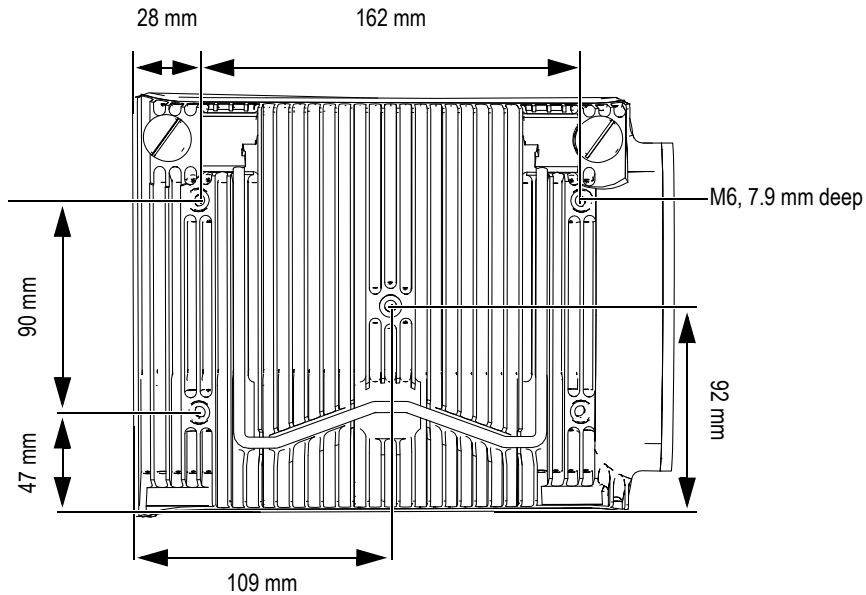

**Figure M-5 Fastening hole location and specifications**

## M.1 Acoustic Specifications

This section details the acoustic specifications of the pulser, receiver, and beam formation, for both UT and PA modes (Table 63 on page 190 and Table 64 on page 191).

**Table 63 Acoustic specifications — UT channel using UT connector**

Pulser	
Voltage	95 V, 175 V, and 340 V
Pulse width	Adjustable from 30 ns to 1000 ns; resolution of 2.5 ns
Fall time	<10 ns
Pulse shape	Negative square pulse
Output impedance	<30 $\Omega$

**Table 63 Acoustic specifications – UT channel using UT connector (continued)**

<b>Receiver</b>	
Gain range	0 dB to 120 dB maximum input signal 34.5 Vp-p (full-screen height)
Input impedance	60 $\Omega$ in pulse-echo mode 50 $\Omega$ in pulse-receive mode
System bandwidth	0.25 MHz to 28 MHz (-3 dB)

**NOTE**

When the UT channel is used in pulse-echo mode, pulses occur on both the P1 and R1 connectors. When pulse-echo mode is selected, Evident recommends using only the P1 connector to connect the probe.

**Table 64 Acoustic specifications – PA channel**

<b>Pulser</b>	
Voltage	40 V, 80 V, and 115 V
Pulse width	Adjustable from 30 ns to 500 ns; resolution of 2.5 ns
Fall time	<10 ns
Pulse shape	Negative square pulse
Output impedance	For 32128PR model: 35 $\Omega$ in pulse-echo 30 $\Omega$ in pitch-catch For other models: 25 $\Omega$
<b>Receiver</b>	
Gain range	0 dB to 80 dB maximum input signal 550 mVp-p (full-screen height).
Input impedance	For 32128PR model: 50 $\Omega$ in pulse-echo 90 $\Omega$ in pitch-catch For other models: 65 $\Omega$

**Table 64 Acoustic specifications — PA channel (continued)**

System bandwidth	0.5 MHz to 18 MHz NOTE: The previously stated 0.6 MHz lower limit used a strict -3 dB attenuation for the cutoff frequency.
<b>Beam formation</b>	
Scan type	Sectorial and linear
Aperture	OMNI-M2-PA1664 = 16 elements OMNI-M2-PA16128 = 16 elements OMNI-M2-PA32128 = 32 elements OMNI-M2-PA32128PR = 32 elements
Number of elements	OMNI-M2-PA1664 = 64 elements OMNI-M2-PA16128 = 128 elements OMNI-M2-PA32128 = 128 elements OMNI-M2-PA32128PR = 128 elements
Number of focal laws	256
Delay range transmission	0 $\mu$ s to 10 $\mu$ s in 2.5 ns increments
Delay range reception	0 $\mu$ s to 6.4 $\mu$ s in 2.5 ns increments

## M.2 Acquisition Specifications

This section lists the acquisition specifications for frequency, data display, and synchronization (Table 65 on page 192).

**Table 65 Acquisition specifications — OMNI-M2-PA $m$** 

<b>Frequency</b>	
Effective digitizing frequency	Up to 100 MHz
A-scan (acquisition mode)	Up to 6000 A-scans per second (512-point, 8-bit A-scan)
Maximum pulsing rate	Up to 10 kHz (C-scan)
Depth in material	59.8 meters in steel (longitudinal wave), 10 ms with compression 0.49 meter in steel (longitudinal wave), 81.9 $\mu$ s without compression



**Table 65 Acquisition specifications — OMNI-M2-PA<sub>nn</sub> (continued)**

<b>Display</b>	
Refresh rate	A-scan: 60 Hz; S-scan: 20 Hz to 30 Hz
Envelope (echo-dynamic mode)	Yes: Volume-corrected S-scan (30 Hz)
<b>Synchronization</b>	
On internal clock	1 Hz to 10 kHz
External pace	Yes
On encoder	On 2 axes: from 1 to 65536 steps

### M.3 Data Specifications

This section details the data specifications of processing, TCG, and storage (Table 66 on page 193).

**Table 66 Data specifications — OMNI-M2-PA<sub>nn</sub>**

<b>Processing</b>	
Number of data points	Up to 8192
Real-time averaging	PA: 2, 4, 8, 16 UT: 2, 4, 8, 16, 32, 64
Rectification	RF, full wave, half wave+, half wave-
Filtering	PA channel: 3 low-pass, 6 band-pass, and 4 high-pass filters UT channel: 3 low-pass, 6 band-pass, and 4 high-pass filters (3 low-pass filters when configured in TOFD)
Video filtering	Smoothing (adjusted to the probe frequency range)
<b>Programmable TCG</b>	
Number of points	32: One TCG (time-corrected gain) curve per focal law
Range	PA: 40 dB per step of 0.1 dB UT: 100 dB per step of 0.1 dB
Maximum slope	40 dB/10 ns
<b>Storage</b>	

**Table 66 Data specifications – OMNI-M2-PA<sub>nn</sub> (continued)**

A-scan recording	6000 A-scans per second (512-point, 8-bit A-scan)
C-scan recording	I, A, B, up to 10 kHz
Maximum file size	Limited to available internal flash memory: 300 MB

## Appendix N: OMNI-M2-UT-2C Module Specifications



### CAUTION

- To reduce the risk of electric shock, avoid touching the inner conductor of the LEMO connectors. Up to 340 V can be present on the inner conductor of the UT connectors. The warning symbol near the LEMO connectors signals this electric shock risk (Figure N-1 on page 195).
- Reinforced insulation must be provided for the probes connected to the module.

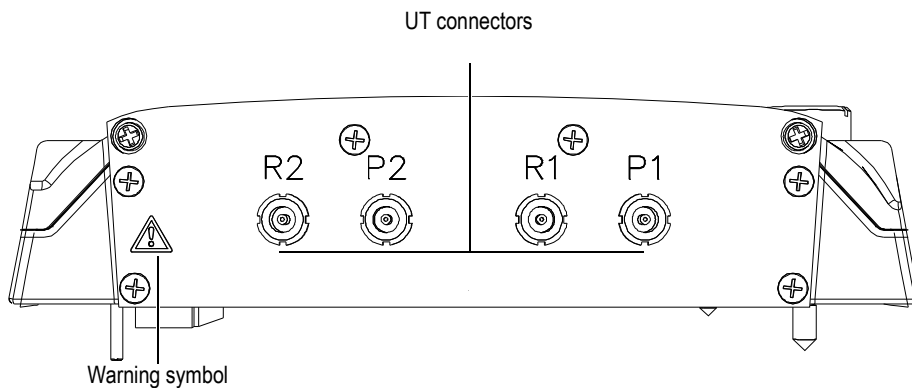
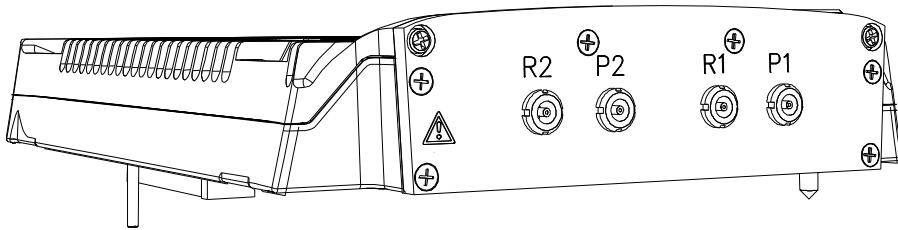

Figure N-1 Module side view

This appendix lists the technical specifications for OmniScan UT acquisition module model OMNI-M2-UT-2C (Figure N-2 on page 196).



**Figure N-2 Module model OMNI-M2-UT-2C**

You can also attach accessories to these acquisition modules using the fastening holes (Figure N-3 on page 196).

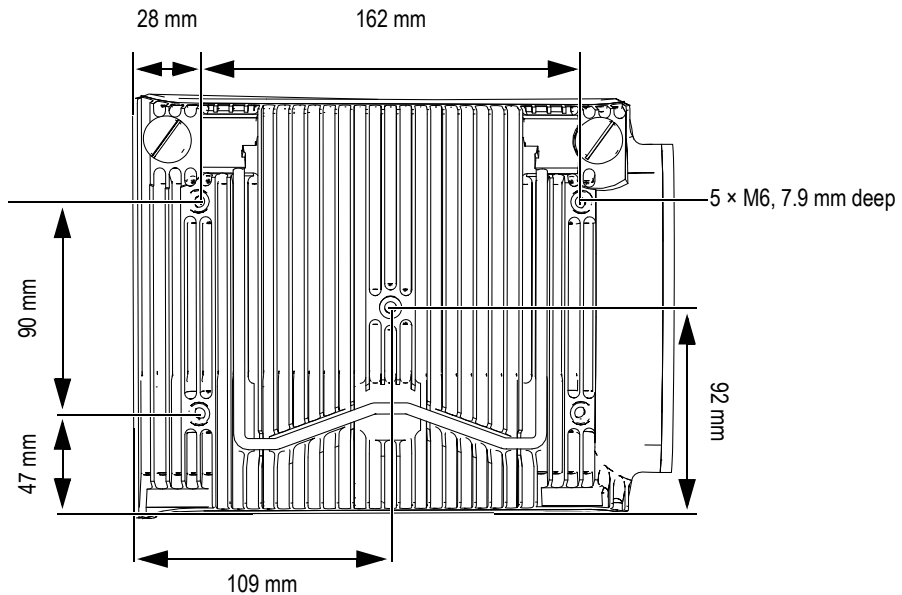

**Figure N-3 Fastening hole location and specifications**

## N.1 Acoustic Specifications

This section details the acoustic specifications of the pulser, receiver, and beam formation (Table 67 on page 197).

**Table 67 Acoustic specifications – OMNI-M2-UT-2C**

<b>Pulser</b>	
Voltage	95 V, 175 V, and 340 V
UT channel quantity	2
Pulse-echo mode	Pulser 1 to pulser 1 Pulser 2 to pulser 2
Pitch-and-catch mode	Pulser 1 to receiver 1 Pulser 2 to receiver 2
Pulse width	Adjustable from 30 ns to 1000 ns; resolution of 2.5 ns
Fall time	<10 ns
Pulse shape	Negative square pulse
Output impedance	<30 $\Omega$
<b>Receiver</b>	
Gain range	0 dB to 120 dB maximum input signal 34.5 Vp-p (full-screen height)
Input impedance	64 $\Omega$ in pulse-echo mode 51 $\Omega$ in pulse-receive mode
System bandwidth	0.26 MHz to 27 MHz (-3 dB)

### NOTE

When used in pulse-echo mode, pulses occur on both the P1 and R1 connectors. When pulse-echo mode is selected, Evident recommends using only the P1 connector to connect the probe.

## N.2 Acquisition Specifications

This section lists the acquisition specifications for frequency, data display, and synchronization (Table 68 on page 198).

**Table 68 Acquisition specifications – OMNI-M2-UT-2C**

Frequency	
Digitizing frequency	100 MHz
A-scan (acquisition mode)	Up to 6000 A-scans per second (512-point, 8-bit A-scan)
Maximum pulsing rate	Up to 10 kHz (C-scan)
Depth in material	59.8 meters in steel (longitudinal wave), 10 ms with compression 0.49 meter in steel (longitudinal wave), 81.9 $\mu$ s without compression
Display	
Refresh rate	A-scan: 60 Hz; S-scan: 20 Hz to 30 Hz
Envelope (echo-dynamic mode)	Yes: Volume-corrected S-scan (30 Hz)
Synchronization	
On internal clock	1 Hz to 10 kHz
External pace	Yes
On encoder	On 2 axes: from 1 to 65536 steps

## N.3 Data Specifications

This section details the data specifications of processing, TCG, and storage (Table 69 on page 198).

**Table 69 Data specifications – OMNI-M2-UT-2C**

Processing	
Number of data points	Up to 8192
Real-time averaging	2, 4, 8, 16, 32, 64

**Table 69 Data specifications – OMNI-M2-UT-2C (continued)**

Rectification	RF, full wave, half wave+, half wave-
Filtering	3 low-pass, 6 band-pass, and 3 high-pass filters (8 low-pass filters when configured in TOFD)
Video filtering	Smoothing (adjusted to the probe frequency range)
<b>Programmable TCG</b>	
Number of points	32: One TCG (time-corrected gain) curve per focal law
Range	100 dB per step of 0.1 dB
Maximum slope	40 dB/10 ns
<b>Storage</b>	
A-scan recording	6000 A-scans per second (512-point, 8-bit A-scan).
C-scan recording	I, A, B, up to 10 kHz
Maximum file size	Limited to available internal flash memory: 300 MB





---

## List of Figures

---

Figure 1-1	Front panel of the OmniScan MX2 .....	30
Figure 1-2	Right side panel of the OmniScan MX2 .....	34
Figure 1-3	Left side panel of the OmniScan MX2 .....	35
Figure 1-4	Top panel of the OmniScan MX2 .....	36
Figure 2-1	Shut Down button .....	40
Figure 2-2	Saving the setup .....	40
Figure 2-3	OmniScan MX2 DC power adaptor plug .....	42
Figure 2-4	Battery charge status: Charge remaining in both batteries .....	44
Figure 2-5	Removing a lithium-ion battery .....	46
Figure 2-6	Attaching a ferrite clamp filter to a cable (example shown with the scanner interface cable) .....	51
Figure 2-7	OmniScan MX2 connection diagram — ferrite clamp filters .....	52
Figure 3-1	Module with PA connector cap .....	57
Figure 6-1	Serial connector .....	68
Figure 6-2	Scanner interface LEMO connector (contact view) .....	69
Figure 6-3	Alarm and I/O connector .....	72
Figure 7-1	Front panel of the OmniScan MX / MX1 .....	82
Figure 7-2	Information provided on each key .....	84
Figure 7-3	Right side panel of the OmniScan MX / MX1 .....	89
Figure 7-4	Left side panel of the OmniScan MX / MX1 .....	90
Figure 7-5	Top panel of the OmniScan MX / MX1 .....	91
Figure 8-1	OmniScan MX / MX1 DC power adaptor plug .....	95
Figure 8-2	Battery charge status: Charge remaining in both batteries .....	96
Figure 8-3	Removing the lithium-ion battery .....	98
Figure 8-4	Attaching a ferrite clamp filter to a cable (example shown with the 4CH/MUX cable) .....	103
Figure 8-5	OmniScan MX / MX1 connection diagram indicating where to attach ferrite clamp filters .....	104
Figure 12-1	Serial connector .....	122
Figure 12-2	Scanner interface connector .....	123

Figure 12-3	Alarm and I/O connector .....	126
Figure B-1	BNC, LEMO, and phased array probe connectors .....	136
Figure B-2	Phased array module connector guide location .....	138
Figure B-3	Grill and filter of the OMNI-M-PA32 <i>mn</i> model .....	139
Figure C-1	Phased array module model OMNI-M-PA32128 .....	141
Figure D-1	Modules OMNI-M-UT-2C ( <i>left</i> ) and OMNI-M-UT-8C ( <i>right</i> ) .....	145
Figure E-1	Phased array module models OMNI-M-PA1616M and OMNI-M-PA1664M .....	150
Figure F-1	Phased array module model OMNI-M-PA1616 .....	154
Figure G-1	Phased array module model OMNI-M-PA16128 .....	157
Figure H-1	Phased array module model OMNI-M-PA16128PR .....	162
Figure I-1	Phased array module model OMNI-M-PA32128PR .....	165
Figure J-1	Phased array module model OMNI-M-PA3232 .....	169
Figure K-1	Phased array module model OMNI-M-PA1664 .....	174
Figure L-1	OMNI-M-ECA4-32 and OMNI-M1-ECA4-32 acquisition module .....	178
Figure L-2	ECA module with connectors .....	179
Figure L-3	Evident ECA probe connector .....	180
Figure L-4	19-pin eddy current probe connector .....	180
Figure L-5	Eddy current probe BNC connector .....	180
Figure L-6	4CH connector .....	181
Figure M-1	Module side view .....	187
Figure M-2	Phased array module model OMNI-M2-PA1664/16128/32128/32128PR .....	188
Figure M-3	Module with anchor base .....	188
Figure M-4	Module with PA connector cap .....	189
Figure M-5	Fastening hole location and specifications .....	190
Figure N-1	Module side view .....	195
Figure N-2	Module model OMNI-M2-UT-2C .....	196
Figure N-3	Fastening hole location and specifications .....	196

---

## List of Tables

---

Table 1	Main control area .....	31
Table 2	Power indicator light statuses .....	32
Table 3	Acquisition indicator light statuses .....	33
Table 4	Battery status indicator variations .....	45
Table 5	Ferrite clamp filter locations .....	52
Table 6	Message .....	60
Table 7	OmniScan MX2 general specifications .....	63
Table 8	OmniScan MX2 alarms .....	66
Table 9	Pinout for the serial connector .....	68
Table 10	Pinout for the scanner interface LEMO connector .....	70
Table 11	Pinout for the alarm and I/O connector .....	73
Table 12	Available OmniScan MX1 and discontinued OmniScan MX products .....	78
Table 13	Main control area .....	83
Table 14	Keypad indicator light statuses .....	86
Table 15	Power indicator light statuses .....	87
Table 16	Acquisition indicator light statuses .....	87
Table 17	Battery status indicator variations .....	97
Table 18	Messages .....	110
Table 19	OmniScan MX / MX1 general specifications .....	117
Table 20	OmniScan MX / MX1 alarms .....	119
Table 21	Pinout for the serial connector .....	122
Table 22	Pinout for the scanner interface connector .....	123
Table 23	Pinout for the alarm and I/O connector .....	126
Table 24	Module compatibility .....	129
Table 25	OmniScan MX2 software compatibility .....	130
Table 26	OmniScan MX / MX1 software compatibility .....	131
Table 27	Old accessory compatibility .....	131
Table 28	New accessories compatibility .....	131
Table 29	General specifications for all modules .....	134

Table 30	General specifications – OMNI-M2-PA1664/16128 /32128/32128PR .....	134
Table 31	General specifications – OMNI-M2-UT-2C .....	135
Table 32	Acoustic specifications – OMNI-M-PA32128 .....	142
Table 33	Acquisition specifications – OMNI-M-PA32128 .....	143
Table 34	Data specifications – OMNI-M-PA32128 .....	143
Table 35	Acoustic specifications – OMNI-M-UT- <i>n</i> C .....	146
Table 36	Acquisition specifications – OMNI-M-UT- <i>n</i> C .....	147
Table 37	Data specifications – OMNI-M-UT- <i>n</i> C .....	147
Table 38	Acoustic specifications – OMNI-M-PA16 <i>nm</i> M .....	150
Table 39	Acquisition specifications – OMNI-M-PA16 <i>nm</i> M .....	151
Table 40	Data specifications – OMNI-M-PA16 <i>nm</i> M .....	152
Table 41	Acoustic specifications – OMNI-M-PA1616 .....	154
Table 42	Acquisition specifications – OMNI-M-PA1616 .....	155
Table 43	Data specifications – OMNI-M-PA1616 .....	156
Table 44	Acoustic specifications – OMNI-M-PA16128 .....	158
Table 45	Acquisition specifications – OMNI-M-PA16128 .....	159
Table 46	Data specifications – OMNI-M-PA16128 .....	159
Table 47	Acoustic specifications – OMNI-M-PA16128PR .....	162
Table 48	Acquisition specifications – OMNI-M-PA16128PR .....	163
Table 49	Data specifications – OMNI-M-PA16128PR .....	164
Table 50	Acoustic specifications – OMNI-M-PA32128PR .....	166
Table 51	Acquisition specifications – OMNI-M-PA32128PR .....	167
Table 52	Data specifications – OMNI-M-PA32128PR .....	167
Table 53	Acoustic specifications – OMNI-M-PA3232 .....	170
Table 54	Acquisition specifications – OMNI-M-PA3232 .....	171
Table 55	Data specifications – OMNI-M-PA3232 .....	171
Table 56	Acoustic specifications – OMNI-M-PA1664 .....	174
Table 57	Acquisition specifications – OMNI-M-PA1664 .....	175
Table 58	Data specifications – OMNI-M-PA1664 .....	176
Table 59	Pinout for the 4CH connector [OMNI-M-ECA4-32 and OMNI-M1-ECA4-32 modules] .....	181
Table 60	General specifications – OMNI-M-ECA4-3 and OMNI-M1-ECA4-32 modules .....	183
Table 61	Generator and receiver specifications – OMNI-M-ECA4-32 and OMNI-M1-ECA4-32 .....	183
Table 62	Data specifications – OMNI-M-ECA4-32 and OMNI-M1-ECA4-32 .....	184
Table 63	Acoustic specifications – UT channel using UT connector .....	190
Table 64	Acoustic specifications – PA channel .....	191
Table 65	Acquisition specifications – OMNI-M2-PA <i>nm</i> .....	192
Table 66	Data specifications – OMNI-M2-PA <i>nm</i> .....	193
Table 67	Acoustic specifications – OMNI-M2-UT-2C .....	197

Table 68	Acquisition specifications — OMNI-M2-UT-2C .....	198
Table 69	Data specifications — OMNI-M2-UT-2C .....	198

