



WeldROVER

Motorized Weld Scanner

User's Manual

DMTA060-01EN — Rev. C
September 2022

This instruction manual contains essential information on how to use this Evident product safely and effectively. Before using this product, thoroughly review this instruction manual. Use the product as instructed. Keep this instruction manual in a safe, accessible location.

EVIDENT CANADA, 3415, Rue Pierre-Ardouin, Québec (QC) G1P 0B3 Canada

Copyright © 2022 by Evident. All rights reserved. No part of this publication may be reproduced, translated, or distributed without the express written permission of Evident.

This document was prepared with particular attention to usage to ensure the accuracy of the information contained therein, and corresponds to the version of the product manufactured prior to the date appearing on the title page. There could, however, be some differences between the manual and the product if the product was modified thereafter.

The information contained in this document is subject to change without notice.

Part number: DMTA060-01EN

Rev. C

September 2022

Printed in Canada

All brands are trademarks or registered trademarks of their respective owners and third party entities.

Table of Contents

List of Abbreviations	7
Important Information – Please Read Before Use	9
Intended Use	9
Instruction Manual	9
Device Compatibility	10
Repair and Modification	10
Safety Symbols	10
Safety Signal Words	11
Note Signal Words	12
Safety	12
Warnings	12
Battery Precautions	13
Regulations for Shipping Products with Lithium-Ion Batteries	15
Equipment Disposal	15
BC (Battery Charger - California, USA Community)	15
CE (European Community)	16
UKCA (United Kingdom)	16
RCM (Australia)	16
WEEE Directive	16
China RoHS	17
Korea Communications Commission (KCC)	18
EMC Directive Compliance	18
FCC (USA) Compliance	19
ICES-001 (Canada) Compliance	20
Warranty Information	20
Technical Support	21

- Introduction 23**
- 1. WeldROVER System Overview 25**
 - 1.1 Remote Control 26
 - 1.2 Motion Controller 27
 - 1.3 WeldROVER Motorized Scanner 28
 - 1.3.1 Magnetic Wheels and Related Safety Information 29
 - 1.3.2 Probe Holders 32
- 2. Assembly and Setup Instructions 33**
 - 2.1 Basic Operations 33
 - 2.2 Configurations 43
 - 2.2.1 The Standard Configuration of the WeldROVER 44
 - 2.2.2 Configuration for Three Pairs of Probe 44
 - 2.2.3 Back and Front Configuration 46
 - 2.2.4 Low-Profile Configuration 46
 - 2.2.5 Circumferential Inspection Inside a Pipe 48
 - 2.2.6 Configuration According to PCS 49
 - 2.2.7 Yoke Orientation 56
- 3. Preparation for an Inspection 57**
 - 3.1 WeldROVER Manipulation on Ferromagnetic Surfaces 57
 - 3.2 Adaptation to the Inspection Surface 58
 - 3.3 Cleaning the Magnetic Wheels 63
- 4. WeldROVER Operation 65**
 - 4.1 Basic Operations 65
 - 4.2 Performing an Inspection with the WeldROVER 68
- 5. Accessories and Spare Parts 71**
 - 5.1 WeldROVER Transport Case 71
 - 5.2 WeldROVER System Components 73
 - 5.3 Yokes 74
 - 5.4 Couplant-Feed Units 76
 - 5.5 Connector Reference 76
 - 5.6 WeldROVER Scanner Spare Parts 77
- 6. Technical Specifications 81**

7. WeldROVER System Connectors Description	83
7.1 MCDC-01 connectors	83
7.1.1 Power-In Connector	84
7.1.2 Encoder Out Connector	86
7.1.3 Remote Control Connector	89
7.1.4 Scanner Connector	91
7.1.5 RS-232 Communication Port	93
7.2 WeldROVER Scanner Connectors	94
7.2.1 Control Connector	95
7.2.2 Laser Guide Connector	97
Appendix A: Troubleshooting the MCDC-01	99
Appendix B: Maintenance	101
B.1 Adjustment of the Carbide Wear-Pins on Wedges	101
B.2 Replacing a Conventional Ultrasonic Transducer	102
B.3 Replacing a Phased Array Probe	103
B.4 Unit Cleaning	104
List of Figures	107
List of Tables	109

List of Abbreviations

AC	alternating current
DC	direct current
EFUP	environment-friendly use period
hex.	hexagonal
ID	inside diameter
LED	light emitting diode
N/A	not applicable
OD	outside diameter
P/E	pulse-echo
PA	phased array
PCS	probe center separation
SLA	spring-loaded arm
TOFD	time-of-flight diffraction
UT	ultrasonic testing

Important Information — Please Read Before Use

Intended Use

The WeldROVER is designed to perform nondestructive inspections on industrial and commercial materials.



WARNING

Do not use the WeldROVER for any purpose other than its intended use. It must never be used to inspect or examine human or animal body parts.

Instruction Manual

This instruction manual contains essential information on how to use this product safely and effectively. Before using this product, thoroughly review this instruction manual. Use the product as instructed. Keep this instruction manual in a safe, accessible location.

IMPORTANT

Some of the details of components illustrated in this manual may differ from the components installed on your device. However, the operating principles remain the same.

Device Compatibility

Only use this device with the approved ancillary equipment provided by Evident. Equipment provided by Evident and approved for use with this device is described later in this manual.



CAUTION

Always use equipment and accessories that meet Evident specifications. Using incompatible equipment could cause equipment malfunction and/or damage, or human injury.

Repair and Modification

This device does not contain any user-serviceable parts. Opening the device might void the warranty.



CAUTION

In order to prevent human injury and/or equipment damage, do not disassemble, modify, or attempt to repair the device.

Safety Symbols

The following safety symbols might appear on the device and in the instruction manual:



General warning symbol

This symbol is used to alert the user to potential hazards. All safety messages that follow this symbol shall be obeyed to avoid possible harm or material damage.



High voltage warning symbol

This symbol is used to alert the user to potential electric shock hazards greater than 1000 volts. All safety messages that follow this symbol shall be obeyed to avoid possible harm.

Safety Signal Words

The following safety symbols might appear in the documentation of the device:



DANGER

The DANGER signal word indicates an imminently hazardous situation. It calls attention to a procedure, practice, or the like, which, if not correctly performed or adhered to, will result in death or serious personal injury. Do not proceed beyond a DANGER signal word until the indicated conditions are fully understood and met.



WARNING

The WARNING signal word indicates a potentially hazardous situation. It calls attention to a procedure, practice, or the like, which, if not correctly performed or adhered to, could result in death or serious personal injury. Do not proceed beyond a WARNING signal word until the indicated conditions are fully understood and met.



CAUTION

The CAUTION signal word indicates a potentially hazardous situation. It calls attention to an operating procedure, practice, or the like, which, if not correctly performed or adhered to, may result in minor or moderate personal injury, material damage, particularly to the product, destruction of part or all of the product, or loss of data. Do not proceed beyond a CAUTION signal word until the indicated conditions are fully understood and met.

Note Signal Words

The following note signal words could appear in the documentation of the device:

IMPORTANT

The IMPORTANT signal word calls attention to a note that provides important information, or information essential to the completion of a task.

NOTE

The NOTE signal word calls attention to an operating procedure, practice, or the like, which requires special attention. A note also denotes related parenthetical information that is useful, but not imperative.

TIP

The TIP signal word calls attention to a type of note that helps you apply the techniques and procedures described in the manual to your specific needs, or provides hints on how to effectively use the capabilities of the product.

Safety

Before turning on the device, verify that the correct safety precautions have been taken (see the following warnings). In addition, note the external markings on the device, which are described under “Safety Symbols.”

Warnings



WARNING

General Warnings

- Carefully read the instructions contained in this instruction manual prior to turning on the device.
- Keep this instruction manual in a safe place for further reference.

- Follow the installation and operation procedures.
- It is imperative to respect the safety warnings on the device and in this instruction manual.
- If the equipment is used in a manner not specified by the manufacturer, the protection provided by the equipment could be impaired.
- Do not install substitute parts or perform any unauthorized modification to the device.
- Service instructions, when applicable, are for trained service personnel. To avoid the risk of electric shock, do not perform any work on the device unless qualified to do so. For any problem or question regarding this device, contact Evident or an authorized Evident representative.
- Do not touch the connectors directly by hand. Otherwise, a malfunction or electric shock may result.
- Do not allow metallic or foreign objects to enter the device through connectors or any other openings. Otherwise, a malfunction or electric shock may result.

**WARNING****Electrical Warning**

The device must only be connected to a power source corresponding to the type indicated on the rating label.

**CAUTION**

If a non-approved power supply cord not dedicated to Evident products is used, Evident will not be able to ensure the electrical safety of the equipment.

Battery Precautions**CAUTION**

- Before disposing of a battery, check your local laws, rules, and regulations, and follow them accordingly.

- Transportation of lithium-ion batteries is regulated by the United Nations under the United Nations Recommendations on the Transport of Dangerous Goods. It is expected that governments, intergovernmental organizations, and other international organizations shall conform to the principles laid down in these regulations, thus contributing to worldwide harmonization in this field. These international organizations include the International Civil Aviation organization (ICAO), the International Air Transport Association (IATA), the International Maritime Organization (IMO), the US Department of Transportation (USDOT), Transport Canada (TC), and others. Please contact the transporter and confirm current regulations before transportation of lithium-ion batteries.
- For California (USA) only:
The device may contain a CR battery. The CR battery contains perchlorate material, and special handling may be required. Refer to <http://www.dtsc.ca.gov/hazardouswaste/perchlorate>.
- Do not open, crush, or perforate batteries; doing so could cause injury.
- Do not incinerate batteries. Keep batteries away from fire and other sources of extreme heat. Exposing batteries to extreme heat (over 80 °C) could result in an explosion or personal injury.
- Do not drop, hit, or otherwise abuse a battery, as doing so could expose the cell contents, which are corrosive and explosive.
- Do not short-circuit the battery terminals. A short circuit could cause injury and severe damage to a battery making it unusable.
- Do not expose a battery to moisture or rain; doing so could cause an electric shock.
- Only use an external charger approved by Evident to charge the batteries.
- Only use batteries supplied by Evident.
- Do not store batteries that have less than 40 % remaining charge. Recharge batteries to between 40 % and 80 % capacity before storing them.
- During storage, keep the battery charge between 40 % and 80 %.
- Do not leave batteries in the WeldROVER unit during device storage.

Regulations for Shipping Products with Lithium-Ion Batteries

IMPORTANT

When shipping a Li-ion battery or batteries, be sure to follow all local transportation regulations.



WARNING

Damaged batteries cannot be shipped through normal routes — DO NOT ship damaged batteries to Evident. Contact your local Evident representative or material disposal professionals.

Equipment Disposal

Before disposing of the WeldROVER, check your local laws, rules, and regulations, and follow them accordingly.

BC (Battery Charger - California, USA Community)



The BC marking indicates that this product has been tested and complies with the Appliance Efficiency Regulations as stated in the California Code of Regulations Title 20, Sections 1601 through 1608 for Battery Charger Systems. The internal battery charger within this device has been tested and certified pursuant to the California Energy Commission's (CEC) requirements; this device is listed on the online CEC's (T20) database.

CE (European Community)



This device complies with the requirements of directive 2014/30/EU concerning electromagnetic compatibility, directive 2014/35/EU concerning low voltage, and directive 2015/863 which amends 2011/65/EU concerning restriction of hazardous substances (RoHS). The CE marking is a declaration that this product conforms to all the applicable directives of the European Community.

UKCA (United Kingdom)



This device complies with the requirements of the Electromagnetic Compatibility Regulations 2016, the Electrical Equipment (Safety) Regulations 2016, and the Restriction of the Use of Certain Hazardous Substances in Electrical and Electronic Equipment Regulations 2012. The UKCA marking indicates compliance with the above regulations.

RCM (Australia)



The regulatory compliance mark (RCM) label indicates that the product complies with all applicable standards, and has been registered with the Australian Communications and Media Authority (ACMA) for placement on the Australian market.

WEEE Directive



In accordance with European Directive 2012/19/EU on Waste Electrical and Electronic Equipment (WEEE), this symbol indicates that the product must not be disposed of as unsorted municipal waste, but should be collected separately. Refer to your local Evident distributor for return and/or collection systems available in your country.



China RoHS

China RoHS is the term used by industry generally to describe legislation implemented by the Ministry of Information Industry (MII) in the People's Republic of China for the control of pollution by electronic information products (EIP).



The China RoHS mark indicates the product's Environment-Friendly Use Period (EFUP). The EFUP is defined as the number of years for which listed controlled substances will not leak or chemically deteriorate while in the product. The EFUP for the WeldROVER has been determined to be 15 years.

Note: The Environment-Friendly Use Period (EFUP) is not meant to be interpreted as the period assuring functionality and product performance.



本标志是根据“电器电子产品有害物质限制使用管理办法”以及“电子电气产品有害物质限制使用标识要求”的规定，适用于在中国销售的电器电子产品上的电器电子产品有害物质使用限制标志。

电器电子产品有
有害物质限制使用
标志

（注意）电器电子产品有害物质限制使用标志内的数字为在正常的使用条件下有害物质等不泄漏的期限，不是保证产品功能性能的期间。

产品中有害物质的名称及含量

部件名称		有害物质					
		铅及其化合物 (Pb)	汞及其化合物 (Hg)	镉及其化合物 (Cd)	六价铬及其化合物 (Cr(VI))	多溴联苯 (PBB)	多溴二苯醚 (PBDE)
主体	机构部件	×	○	○	○	○	○
	光学部件	×	○	○	○	○	○
	电气部件	×	○	○	○	○	○

产品中有害物质的名称及含量

部件名称	有害物质					
	铅及其化合物 (Pb)	汞及其化合物 (Hg)	镉及其化合物 (Cd)	六价铬及其化合物 (Cr(VI))	多溴联苯 (PBB)	多溴二苯醚 (PBDE)
附件	×	○	○	○	○	○

本表格依据 SJ/T 11364 的规定编制。

○：表示该有害物质在该部件所有均质材料中的含量均在 GB/T26572 规定的限量要求以下。

×：表示该有害物质至少在该部件的某一均质材料中的含量超出 GB/T26572 规定的限量要求。

Korea Communications Commission (KCC)



Seller and user shall be noticed that this equipment is suitable for electromagnetic equipment for office work (class A) and it can be used outside the home. This device complies with the EMC requirements of Korea.

The MSIP code for the device is the following: MSIP-REM-OYN-WELDROVER.

이 기기는 업무용 환경에서 사용할 목적으로 적합성평가를 받은 기기로서 가정용 환경에서 사용하는 경우 전파간섭의 우려가 있습니다.

EMC Directive Compliance

This equipment generates and uses radio-frequency energy and, if not installed and used properly (that is, in strict accordance with the manufacturer's instructions), may cause interference. The WeldROVER has been tested and found to comply with the limits for an industrial device in accordance with the specifications of the EMC directive.

FCC (USA) Compliance

NOTE

This product has been tested and found to comply with the limits for a Class A digital device, pursuant to Part 15 of the FCC Rules. These limits are designed to provide reasonable protection against harmful interference when the product is operated in a commercial environment. This product generates, uses, and can radiate radio frequency energy, and if not installed and used in accordance with the instruction manual, might cause harmful interference to radio communications. Operation of this product in a residential area is likely to cause harmful interference, in which case you will be required to correct the interference at your own expense.

IMPORTANT

Changes or modifications not expressly approved by the party responsible for compliance could void the user's authority to operate the product.

FCC Supplier's Declaration of Conformity

Hereby declares that the product,

Product name: WeldROVER

Model: WeldROVER-MR/WeldROVER-CW

Conforms to the following specifications:

FCC Part 15, Subpart B, Section 15.107 and Section 15.109.

Supplementary information:

This device complies with Part 15 of the FCC Rules. Operation is subject to the following two conditions:

- (1) This device may not cause harmful interference.
- (2) This device must accept any interference received, including interference that may cause undesired operation.

Responsible party name:

EVIDENT CANADA

Address:

3415, Rue Pierre-Ardouin, Québec (QC) G1P 0B3 Canada

Phone number:

+1 781-419-3900

ICES-001 (Canada) Compliance

This Class A digital apparatus complies with Canadian ICES-001.

Cet appareil numérique de la classe A est conforme à la norme NMB-001 du Canada.

Warranty Information

Evident guarantees your Evident product to be free from defects in materials and workmanship for a specific period, and in accordance with conditions specified in the Terms and Conditions available at <https://www.olympus-ims.com/en/terms/>.

The Evident warranty only covers equipment that has been used in a proper manner, as described in this instruction manual, and that has not been subjected to excessive abuse, attempted unauthorized repair, or modification.

Inspect materials thoroughly on receipt for evidence of external or internal damage that might have occurred during shipment. Immediately notify the carrier making the delivery of any damage, because the carrier is normally liable for damage during shipment. Retain packing materials, waybills, and other shipping documentation needed in order to file a damage claim. After notifying the carrier, contact Evident for assistance with the damage claim and equipment replacement, if necessary.

This instruction manual explains the proper operation of your Evident product. The information contained herein is intended solely as a teaching aid, and shall not be used in any particular application without independent testing and/or verification by the operator or the supervisor. Such independent verification of procedures becomes increasingly important as the criticality of the application increases. For this reason, Evident makes no warranty, expressed or implied, that the techniques, examples, or procedures described herein are consistent with industry standards, nor that they meet the requirements of any particular application.

Evident reserves the right to modify any product without incurring the responsibility for modifying previously manufactured products.

Technical Support

Evident is firmly committed to providing the highest level of customer service and product support. If you experience any difficulties when using our product, or if it fails to operate as described in the documentation, first consult the user's manual, and then, if you are still in need of assistance, contact our After-Sales Service. To locate the nearest service center, visit the Service Centers page on the Evident Scientific Web site.

Introduction

This manual provides instructions for assembling, installing, and operating the WeldROVER scanner. The WeldROVER can be configured with up to six probes for phased array (PA), time-of-flight diffraction (TOFD), and conventional pulse-echo (P/E) inspection. The system can easily be set up for weld inspections.

To help users understand and safely operate the system, the manual includes the following subject matter:

- The WeldROVER system's main components
- Assembly and setup
- Preparation for inspection
- Scanner operation
- Spare parts, with exploded view diagram and descriptions
- Technical specifications
- System connectors

1. WeldROVER System Overview

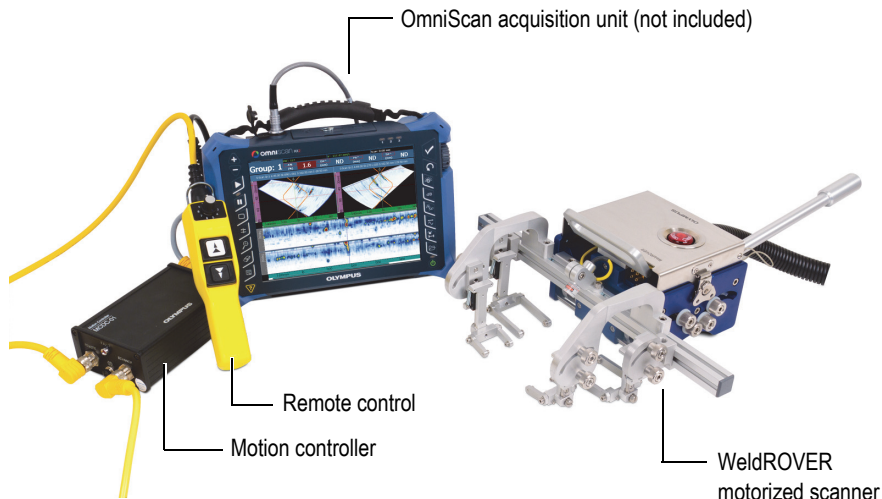

Figure 1-1 WeldROVER system

The WeldROVER is a motorized scanner for conventional UT and phased array inspections. The main purpose of the system is to help perform weld inspections on ferromagnetic pipes or pressure vessels without the need of a welding band.

The motorization, remote control, and compact design features of the WeldROVER allow you to achieve constant-speed inspections that would otherwise be difficult to realize with a manual scanner.

The WeldROVER system is fully compatible with the OmniScan acquisition unit (not included), and with the TomoScan FOCUS LT unit (not included). An encoder adaptor may be required (Table 3 on page 74).

1.1 Remote Control

The WeldROVER is a motorized scanner that comes with a remote control. The remote control is equipped with three buttons that control the scanner's speed and motion in a forward and backward direction (Figure 1-2 on page 26). The commands are transmitted by the remote control to a one-axis motion-control unit (MCDC-01) that drives the scanner motor.

The speed is set using a rotary button that is graded from 1 to 10, where 1 represents the lowest speed (5.0 mm/s), and 10 represents the highest speed (50 mm/s). The scanner speed can be adjusted gradually when the scanner is in motion. The forward and backward motions are carried out using 2-step push buttons. Pressing half way down provides a jog motion, and pressing all the way down provides a continuous motion. When the scanner is in continuous motion, pressing either of the two buttons stops the scanner's motion.



Figure 1-2 WeldROVER — remote control

1.2 Motion Controller

The MCDC-01 is a compact, one-axis DC motion controller that provides a range of scan speeds. The MCDC-01 interprets the information coming from the remote control, and drives the scanner motor accordingly. The unit also transfers the encoder signal to an acquisition unit.

The MCDC-01 has four main connectors: REMOTE, SCANNER, power in, and ENCODER OUT (Figure 1-3 on page 27 and Figure 1-4 on page 28). There is also an RS-232 communication port. This port is reserved for support and advanced troubleshooting by Evident specialists.

A FAULT LED lights up when internal sensors detect that a threshold has been exceeded for more than two seconds (see “Troubleshooting the MCDC-01” on page 99).



Figure 1-3 MCDC-01 – motion control unit (LED panel)

IMPORTANT

When you turn on the MCDC-01, the fault LED flashes twice. This is a confirmation signal that indicates that the LED is functioning correctly. If this occurs, you can assume that the MCDC-01 configuration is correct.



Figure 1-4 MCDC-01 – motion control unit (switch panel)

The LED on the power switch illuminates green when the MCDC-01 is turned on.

1.3 WeldROVER Motorized Scanner

The motorized scanner (Figure 1-5 on page 29) contains the following main elements:

- Magnetic wheels (page 29)
- Probe holders (page 32)

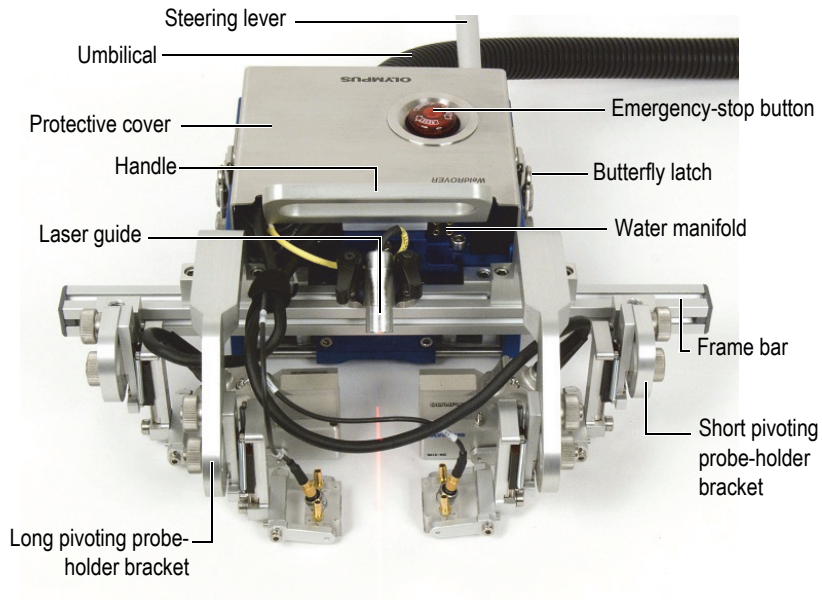

Figure 1-5 WeldROVER scanner — main components

1.3.1 Magnetic Wheels and Related Safety Information

The WeldROVER uses magnetic attraction forces to maintain contact with a ferromagnetic surface. The wheels on the WeldROVER contain strong magnets (Figure 1-6 on page 30). Each front wheel can hold up to 37 kg (82.5 lb), and each back wheel can hold up to 29 kg (65 lb). Because of the strong attractive forces, the motorized scanner must be handled with care. Be sure to observe the following important safety information and procedures.

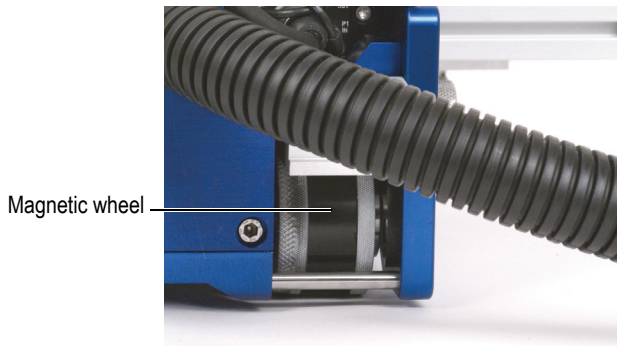

Figure 1-6 WeldROVER scanner – magnetic wheel



WARNING



The WeldROVER generates a magnetic field strong enough to affect pace makers, watches, and other sensitive electronic devices, and anyone wearing or depending on such devices should keep a safe distance away from the WeldROVER to avoid the risk of serious injuries or death. This magnetic field can also demagnetize credit cards, magnetic ID (identification) badges, etc.



CAUTION



To avoid the risk of injuries and equipment damage, be careful when approaching a ferromagnetic surface with the WeldROVER. The wheels' magnetic force is strong and the scanner will be attracted to the surface without warning. Ensure that your feet have a solid grip on the floor. Use a rubber carpet when the floor is wet and slippery.

**WARNING**

To avoid the risk of serious injuries, or death, and equipment damage, always ensure that the surface to be inspected is made of continuous ferromagnetic material. If there is an interruption in the ferromagnetic surface, the WeldROVER can break away and fall down. Always use a lanyard for safety.

**CAUTION**

To avoid the risk of equipment damage or potential injuries, whenever there is a weld across the inspection path of the WeldROVER, be sure to grind this weld flush against the surface. Doing this protects the wedges from bumping against a raised weld, and it also ensures a continuous wedge-to-surface contact.

**WARNING**

To avoid the risk of serious injuries or death, always use a lanyard for safety. The scanner must always be secured using a proper lanyard when used at a height higher than 2 meters above the ground.

**CAUTION**

The magnetic wheels of the WeldROVER exert strong magnetic attractive forces. Sharp filings can be attracted to the wheels, which can cause equipment malfunction or injuries (see “Cleaning the Magnetic Wheels” on page 63 for the proper cleaning procedure).

1.3.2 Probe Holders

The WeldROVER comes with three types of probe holders: a short probe holder, a short pivoting-probe holder, and a long pivoting-probe holder (Figure 1-7 on page 32).

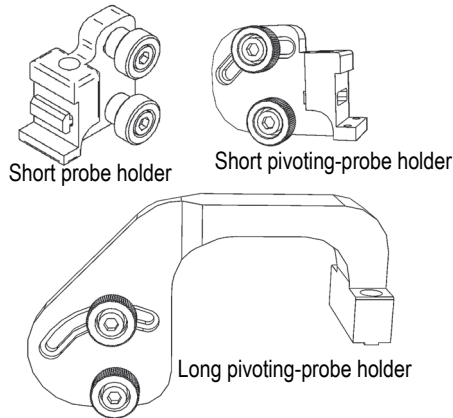

Figure 1-7 WeldROVER—Three types of probe holder

Each probe holder type has a unique installation configuration that uses t-nuts to connect the parts. The probe holders can be adjusted using the supplied hexagonal key. Typical configurations are illustrated in Figure 2-11 on page 45 and Figure 2-12 on page 45.

Short probe holder

This probe holder is attached to the frame bar with one 90-degree elbow screw. It fits the rear vertical face of the frame bar, and must be used with the offset bracket (for offset bracket details, see “To install the offset bracket” on page 45).

Short pivoting-probe holder

This probe holder is attached to the frame bar with one 90-degree elbow screw. It fits the front vertical face of the frame bar.

Long pivoting-probe holder

This probe holder is attached to the frame bar with two screws. It fits the upper horizontal face of the frame bar.

2. Assembly and Setup Instructions

The WeldROVER's design lets you easily change and adjust parts. This chapter illustrates several examples of part changes and adjustments for basic operations and configurations.

2.1 Basic Operations

WeldROVER operators typically must perform the following basic operations:

- Use the emergency-stop button (for details see page 33)
- Remove and/or replace the protective cover (for details see page 34)
- Connect the umbilical to the WeldROVER (for details see page 36)
- Adjust the position of the laser guide (for details see page 39)
- Remove and install the frame bar (for details see page 40)
- Remove and install the steering lever (for details see page 41)
- Remove and install the handle (for details see page 42)
- Remove and install a probe holder (for details see page 43)

To use the emergency-stop button

When the emergency-stop button is pressed (engaged), the power to the motion controller is cut off (Figure 2-1 on page 34). The remote controller no longer communicates with the scanner, and the laser guide turns off. The system remains disabled as long as the emergency-stop button is engaged. When the emergency-stop button is disengaged, the system will return to normal operation.

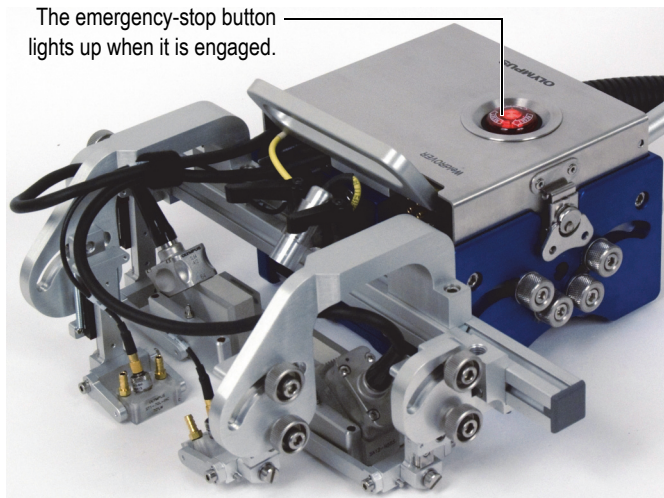

Figure 2-1 WeldROVER—emergency-stop button

1. To stop the WeldROVER immediately, press the emergency-stop button.
 - The scanner stops ongoing motion immediately, without controlled deceleration.
 - The emergency-stop button lights up.
2. To disengage (release) the emergency-stop button, press and twist it clockwise.

IMPORTANT

The emergency-stop button is intended to be used in emergency situations only. Under normal circumstances, the scanner's motion is stopped with the remote controller. The emergency-stop button should not be considered as, or be used as, a simple stop button.

To remove or replace the protective cover

1. On each side of the scanner, lift the butterfly latch (Figure 2-2 on page 35).

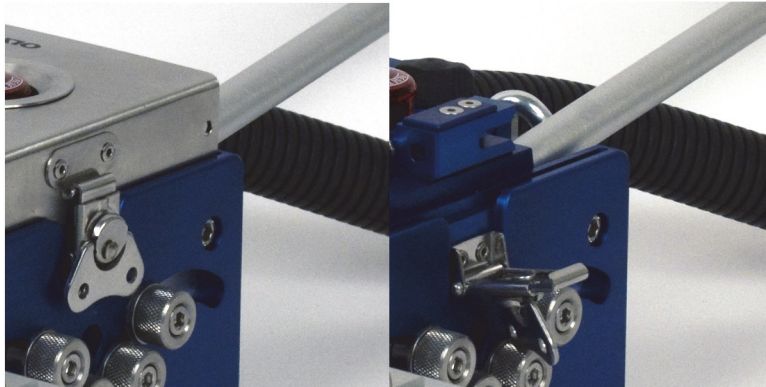

Figure 2-2 WeldROVER— butterfly latches

2. Turn the butterfly latches counterclockwise to unhook the latch.
3. Remove the protective cover.
4. To reinstall the protective cover, reverse the above operation.



CAUTION

To avoid cable damage when reinstalling the protective cover, make sure to avoid pinching the cables between the cover and frame.

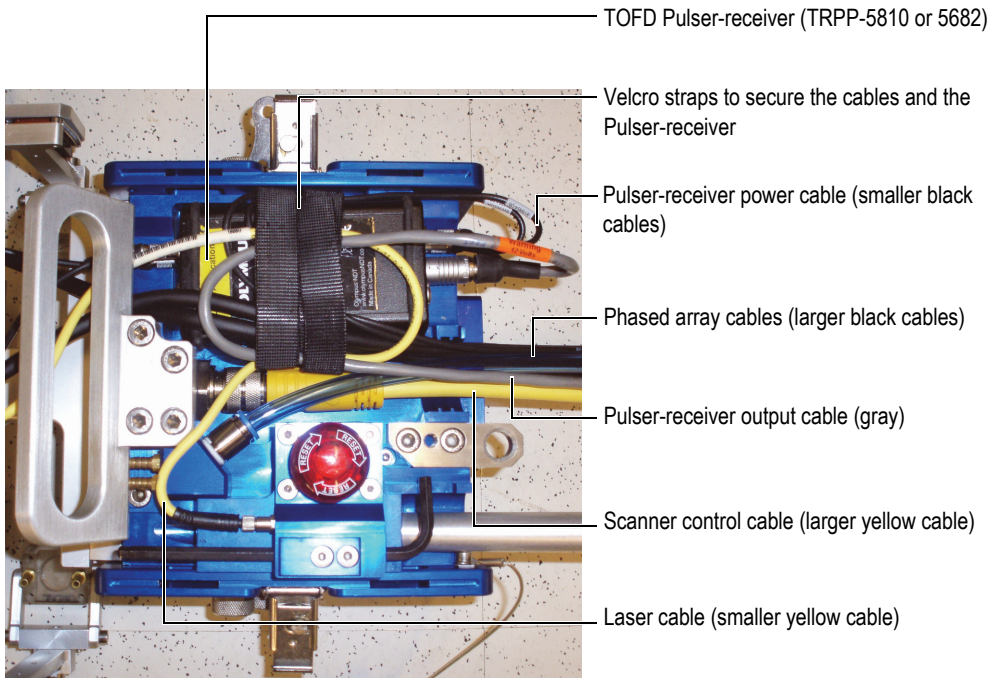

Figure 2-3 WeldROVER—distribution of the main elements under the cover

To connect the umbilical to the WeldROVER

1. Remove the protective cover (see “To remove or replace the protective cover” on page 34).
2. Connect and install the water tube, the control cable, and the optional items, such as probes and pulser/receiver.
3. Unscrew the wing knob to release the clamp on the fastening device (Figure 2-4 on page 37).

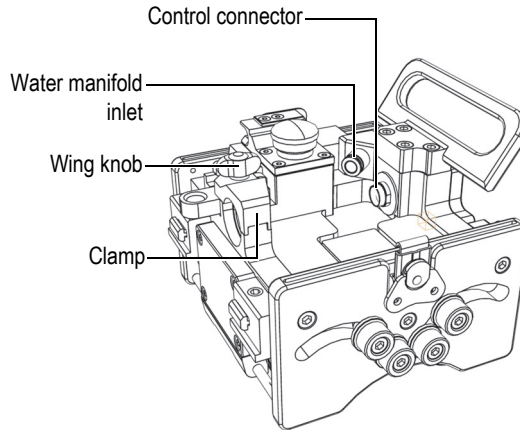

Figure 2-4 WeldROVER—umbilical fastening mechanism and connectors

4. Pivot the clamp to open the divisible conduit attachment.
5. Align the divisible conduit with the divisible conduit attachment.
6. If required, use the supplied draw-in tool (Evident part number 54EC0282) to insert the cable bundle into the divisible cable conduit (Figure 2-5 on page 38):
 - a) Insert the cable bundle into the supplied draw-in tool (see step A in Figure 2-5 on page 38).
 - b) Insert the base of the draw-in tool into the slot on the divisible conduit (see step B in Figure 2-5 on page 38).
 - c) Slowly pull the draw-in tool to insert the cable bundle into the divisible conduit (see step C in Figure 2-5 on page 38).

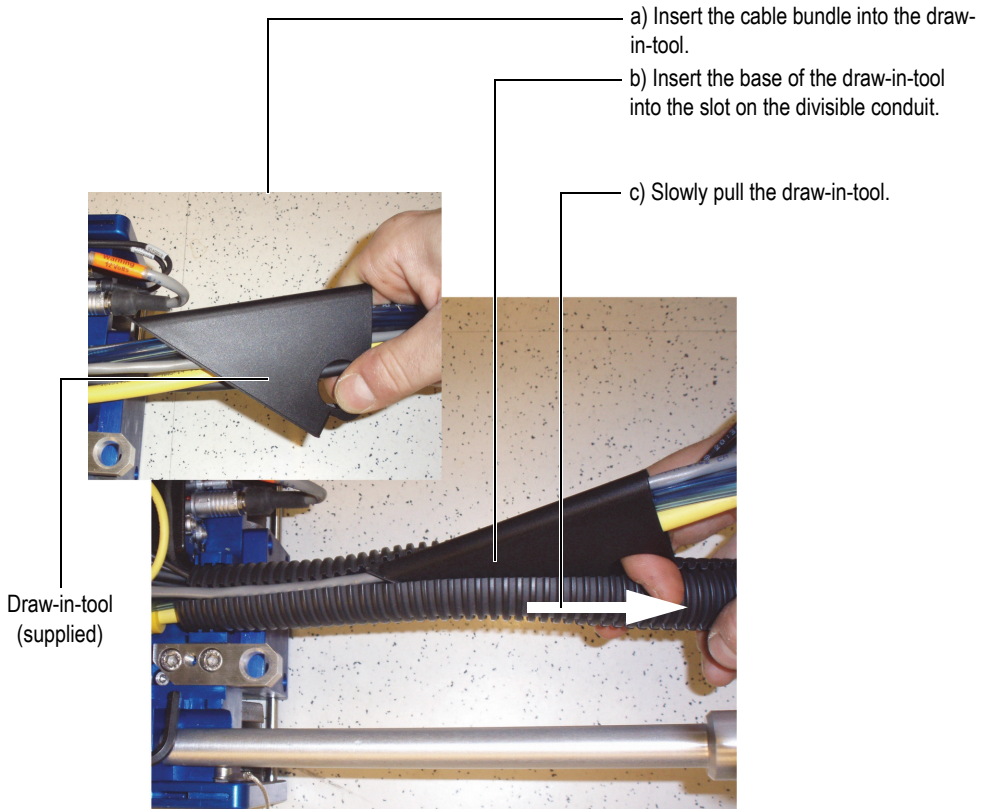

Figure 2-5 Umbilical—draw-in-tool and divisible conduit

TIP

When several cables need to be inserted into the divisible conduit, it can be difficult to insert the entire cable bundle in a single pass. In this case, the cables can be inserted using more than one pass.

7. Install the overall shell over the divisible conduit (Figure 2-6 on page 39).

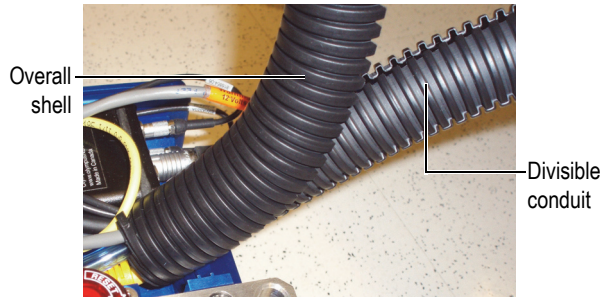

Figure 2-6 Umbilical –the overall shell over the divisible conduit

8. Insert the divisible cable protection spiral into the grooves of the divisible conduit attachment.
9. Close the clamp over the umbilical.
10. Screw the wing knob on tightly to secure the umbilical.
11. Replace the protective cover.

To adjust the position of the laser guide

1. Loosen the laser guide attachment screws (Figure 2-7 on page 40).
2. Slide the laser guide along the frame bar.
3. Tighten the laser guide attachment screws.

To adjust the laser-line angle

1. Loosen the laser guide adjustment screw.
2. Fine-tune the adjustment by manually rotating the laser casing in the holder (Figure 2-7 on page 40).
3. Tighten the laser guide adjustment screw.

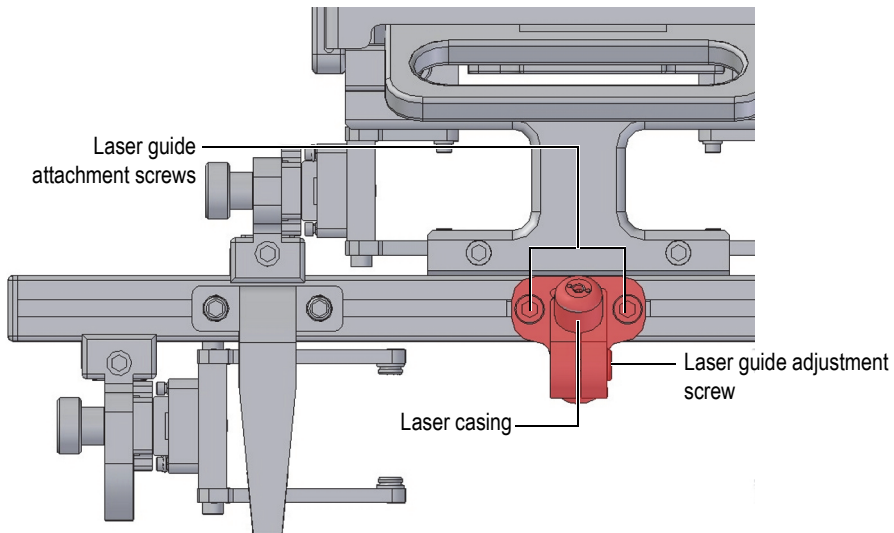

Figure 2-7 WeldROVER—laser guide position adjustment

To remove or install the frame bar

1. Remove the plastic cap from one end of the frame bar.
2. Use the supplied hexagonal key to loosen the screws located on each of the probe holder arms (Figure 2-8 on page 41).
3. Slide the frame bar out.
4. To install the frame bar, reverse the above operation.

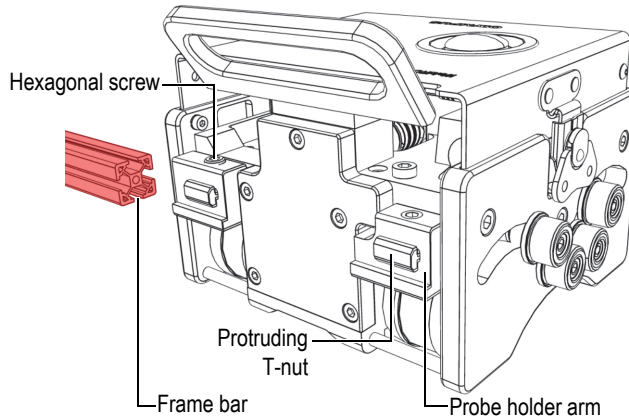

Figure 2-8 WeldROVER—Installing the frame bar

To remove or install the steering lever

Two steering levers are provided with the WeldROVER system. The steering lever is used to adjust and correct the scanner's direction when required (see "To align the WeldROVER with the weld" on page 66). A steering lever is also required on the back (rear) of the WeldROVER when removing or installing the it over a ferromagnetic surface (see "To install the WeldROVER onto a ferromagnetic surface" on page 57).

1. Determine the required steering lever position(s): at the front or back of the WeldROVER, or at both locations (Figure 2-9 on page 42).
2. Insert the steering lever into the WeldROVER, and then turn it clockwise to screw it in.
3. To remove the steering lever, reverse the above operation.

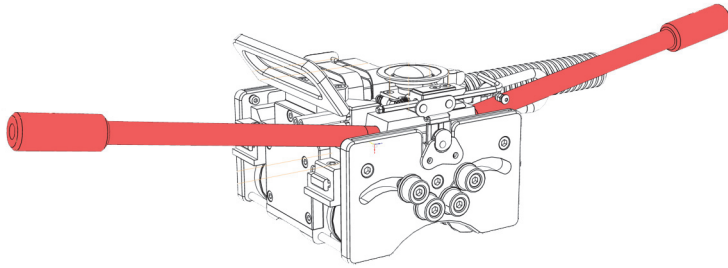

Figure 2-9 WeldROVER—Two steering levers are provided with the system

To remove or install the handle

The handle can be removed if it is necessary to reduce the height clearance of the scanner.

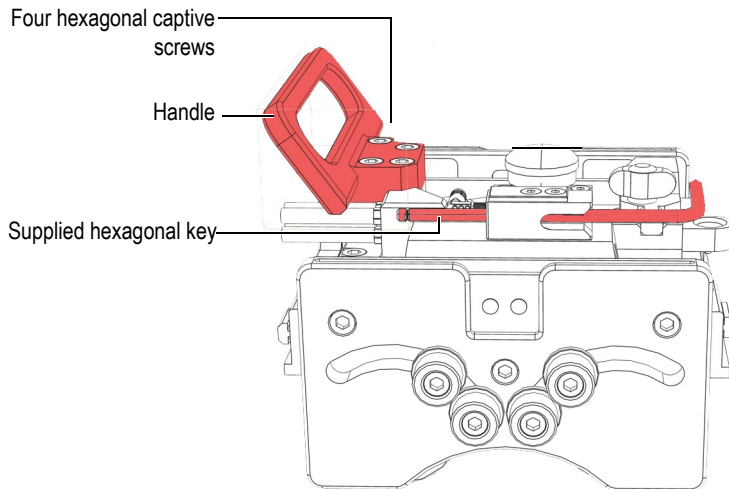

Figure 2-10 WeldROVER—removing the handle

1. Remove the protective cover (see “To remove or replace the protective cover” on page 34).

2. Use the supplied hexagonal key to unscrew the four captive screws (Figure 2-10 on page 42).
3. Remove the handle.
4. Reinstall the protective cover.
5. To install the handle, reverse the above operation.

To install or remove a probe holder

1. Loosen either one or two hexagonal screws on the probe holder, depending on the selected type of probe holder (see “Probe Holders” on page 32).
2. Insert the t-nut into the appropriate groove on the frame bar (Figure 2-8 on page 41).
3. Slide the probe holder along the frame bar into the approximate operating position.
4. Tighten either one or two hexagonal screws on the probe holder, depending on the probe-holder type.
5. To remove a probe holder, reverse the above operation.

See “Maintenance” on page 101 for wedge-probe assembly maintenance.

2.2 Configurations

The WeldROVER can employ three types of ultrasonic testing probes at the front of the scanner:

- Phased array (PA) probes
- Time-of-flight-diffraction (TOFD) probes
- Pulse/echo (P/E) probes

The WeldROVER is designed to perform weld inspections for a wide range of situations on ferromagnetic surfaces (see Table 1 on page 44 for inspections on plates and pipe exteriors). The following common configurations are possible on the WeldROVER:

- Standard configuration (for details, see page 44)
- Three-pair probe configuration (for details, see page 44)
- Back-and-front configuration (for details, see page 46)
- Low-profile configuration (for details, see page 46)

- Pipe-interior circumference configuration (for details, including pipe diameter ranges, see page 48)
- PCS configuration (for details, see page 49)

Table 1 WeldROVER—number of probes according to diameter

Outside diameter range	Front of the scanner	Back of the scanner	Total
10 cm (4 in.) to flat	2	2	4
30 cm (12 in.) to flat	4	2	6
40 cm (16 in.) to flat	6	2	8

2.2.1 The Standard Configuration of the WeldROVER

The standard configuration for pressure vessels, or pipes inspections, is the one that counts two pairs of probes at the front of the scanner (Figure 1-5 on page 29). This configuration is suitable for circumferential scans on pipes with 305 mm (12 in.) outside diameters (OD) and up. For longitudinal scans, the OD is 762 mm (30 in.) and up with this configuration.

2.2.2 Configuration for Three Pairs of Probe

The WeldROVER can support up to three pairs of probes at the front of the scanner for pipes 406 mm (16 in.) OD and up (circumferential scans), and 762 mm (30 in.) OD and up (longitudinal scans). However, this configuration has some limitations (Figure 2-11 on page 45).

- The offset bracket is required (see “To install the offset bracket” on page 45).
- The probe holder used between the body of the WeldROVER and the frame bar must be the short probe holder type; not the pivoting type (Figure 1-7 on page 32).
- Small probes—such as TOFD or P/E—are preferable, because they easily fit between the body and the frame bar.

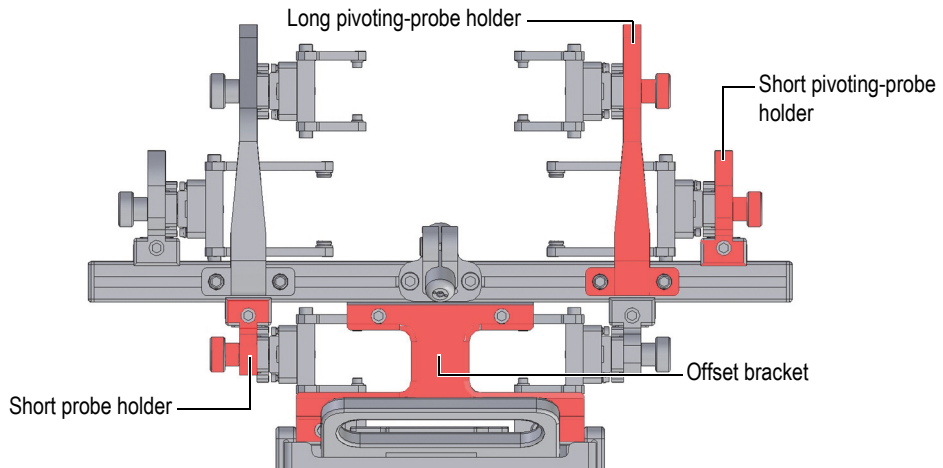

Figure 2-11 WeldROVER—example of a three-pair probe configuration

To install the offset bracket

1. Remove the frame bar (see “To remove or install the frame bar” on page 40).
2. Slide the offset bracket onto the protruding t-nuts on the probe-holder arms.
3. Tighten the hexagonal screws.
4. Install the frame bar onto the offset bracket (see “To remove or install the frame bar” on page 40).

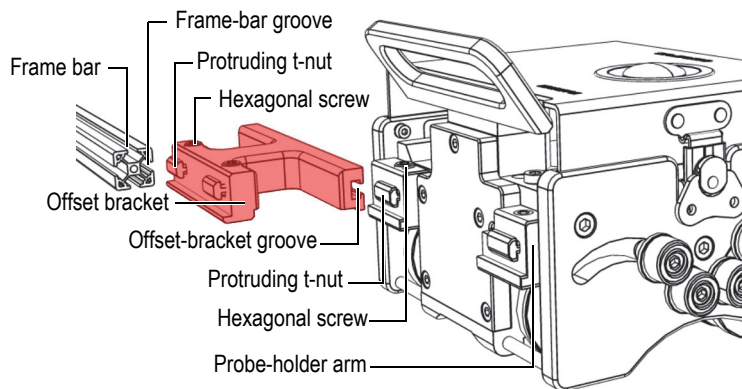

Figure 2-12 WeldROVER—installing the offset bracket

5. Install the various probe holders, SLAs (spring-loaded arms), yokes, and wedges.

2.2.3 Back and Front Configuration

For circumferential scans, the WeldROVER can also support two probes at the back and two at the front of the scanner for pipes 102 mm (4 in.) OD and up (Figure 2-13 on page 46).

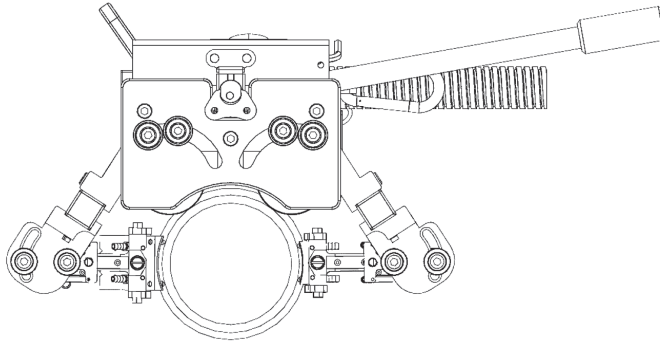

Figure 2-13 WeldROVER—an example of a back and front configuration

NOTE

The back and front configuration requires four short pivoting-probe holders.

2.2.4 Low-Profile Configuration

When space is limited, the height clearance of the WeldROVER can be reduced by making the following adjustments:

- Remove the steering lever (see “To remove or install the steering lever” on page 41).
- Remove the protective cover (see “To remove or replace the protective cover” on page 34).
- Remove the handle (see “To remove or install the handle” on page 42).

- Use the short pivoting-probe holder instead of the long pivoting-probe holders (Figure 1-7 on page 32).
- For a 4-probe configuration, use the back and front configuration (see “Back and Front Configuration” on page 46).

When all peripheral components have been removed, the WeldROVER has a height clearance of 134.5 mm (5.30 in.) on a flat surface (Figure 2-14 on page 47) and a radial clearance of 122.0 mm (4.8 in.) on a 114.3 mm (4.5 in.) OD pipe (Figure 2-15 on page 48).

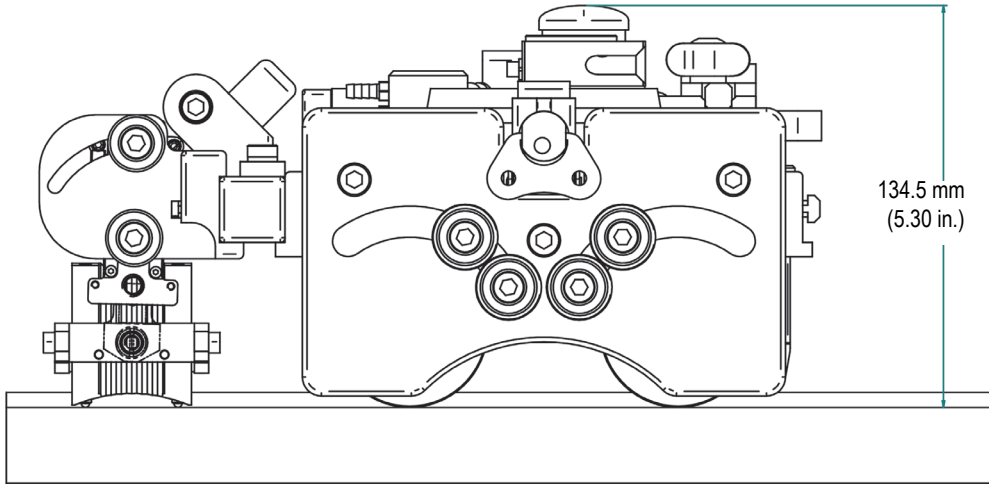

Figure 2-14 WeldROVER – clearance with low-profile configuration – flat surface

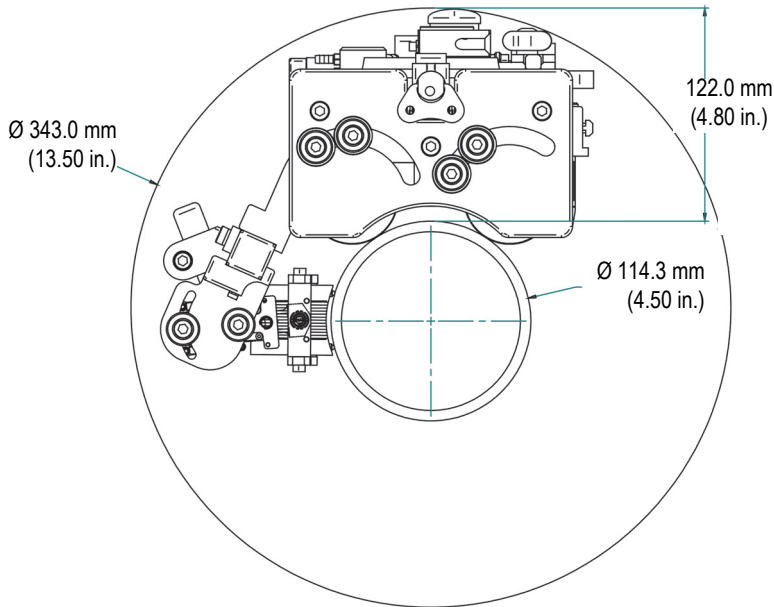

Figure 2-15 WeldROVER—radial clearance—low-profile configuration

2.2.5 Circumferential Inspection Inside a Pipe

The WeldROVER can inspect the interior of large pipes. The minimum pipe diameter depends on the probe configuration (Figure 2-16 on page 48, Figure 2-17 on page 49, and Figure 2-18 on page 49).

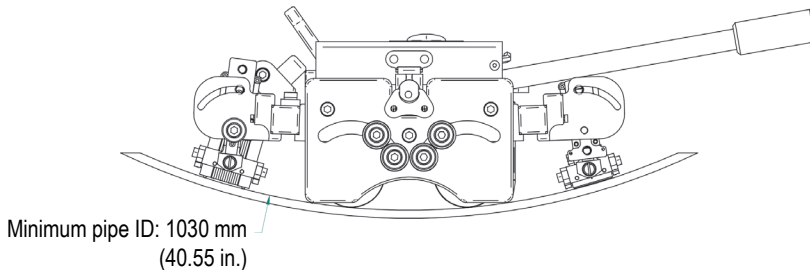

Figure 2-16 WeldROVER—two probes at the front and two probes at the back

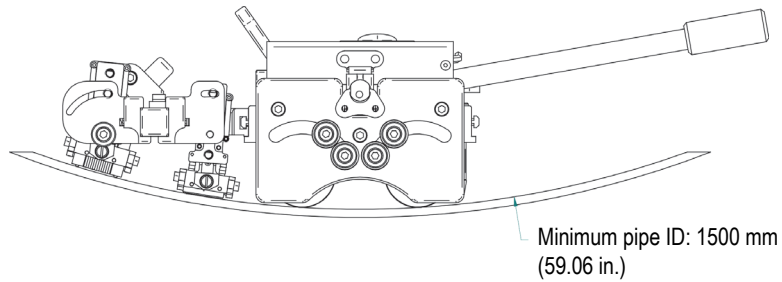

Figure 2-17 WeldROVER—four probes at the front

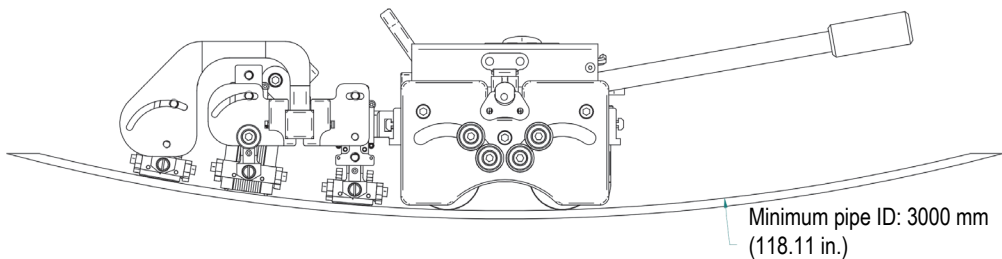

Figure 2-18 WeldROVER—six probes at the front

2.2.6 Configuration According to PCS

Your choice of configuration is based on your scan plan. The scan plan must be completed before you finalize the probe configuration on the scanner. After you have decided on the probe models to use and the probe-center separation values (PCS), consult Table 2 on page 51 to determine the correct configuration.

IMPORTANT

The WeldROVER can be used to inspect pipes as small as 762 mm (30 in) OD in the axial direction. However, some PCS, probe, and diameter combinations may not be possible. For example, the greater the PCS and the smaller the diameter, the more difficult the configuration will be. Always test your configuration to make sure that it is possible before planning your inspection.

With a pair of PA wedges, the PCS is measured from the face of the wedge to the face of the other wedge (Figure 2-20 on page 51). The yoke-arm length is measured from the pivot button to the yoke's rear member (Figure 2-19 on page 50).

For TOFD, the PCS is measured between the two beam-exit points (Figure 2-21 on page 51).

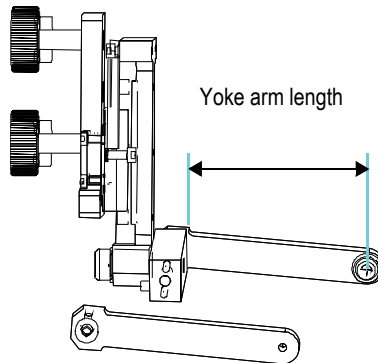

Figure 2-19 WeldROVER—Yoke arm length measurement

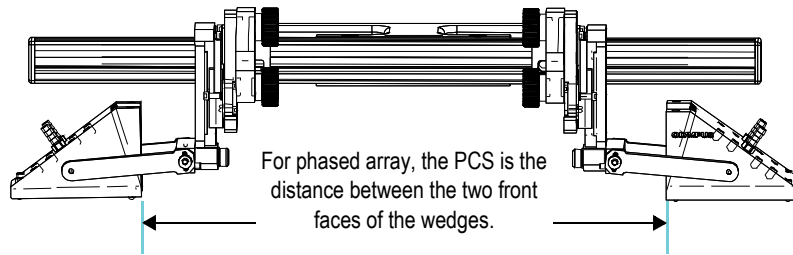

Figure 2-20 WeldROVER—PCS measurement for PA wedges

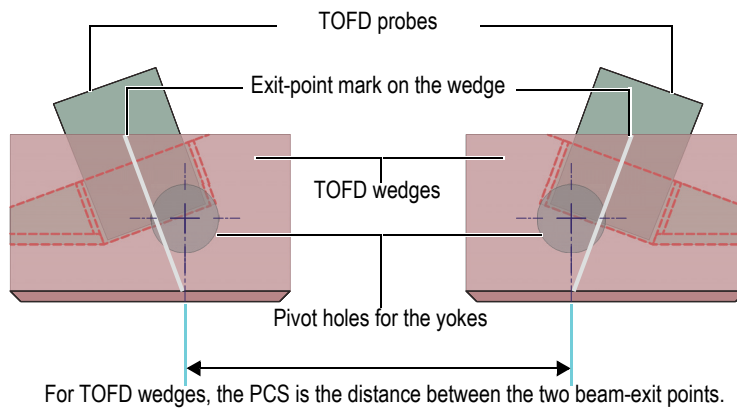

Figure 2-21 WeldROVER—PCS measurement for TOFD wedges

Table 2 WeldROVER—Probe-center separation (PCS) for typical wedges

Wedge type	Probe holder type ^a	PCS	Yoke arm length ^b	Yoke orientation ^c	Figure
SA12	Short pivoting	0 mm to 148 mm	55 mm	Standard	Figure 2-22 (A.)
		142 mm to 498 mm	46 mm	Reverse	Figure 2-22 (B-1.) and (B-2.)
SPWZ1 and SA14	Short pivoting	0 mm to 128 mm	65 mm	Standard	Figure 2-23 (A.)
		126 mm to 486 mm	46 mm	Reverse	Figure 2-23 (B-1.) and (B-2.)

Table 2 WeldROVER—Probe-center separation (PCS) for typical wedges

Wedge type	Probe holder type ^a	PCS	Yoke arm length ^b	Yoke orientation ^c	Figure
TOFD (ST1 and ST2)	Short	0 mm to 285 mm	23.5 mm	Standard	Figure 2-24 (A.)
		260 mm to 527 mm		Reverse	Figure 2-24 (B-1.) and (B-2.)
	Short pivoting	0 mm to 285 mm		Standard	Figure 2-24 (A.)
		175 mm to 527 mm		Reverse	Figure 2-24 (B-1.) and (B-2.)
	Long pivoting	0 mm to 260 mm		Standard	Figure 2-24 (A.)
		230 mm to 501 mm		Reverse	Figure 2-24 (B-1.) and (B-2.)

- For details on the different probe holder types, see Figure 1-7 on page 32.
- For yoke arm-length measurement, see Figure 2-19 on page 50.
- For the procedure to reverse the yoke orientation, see “Yoke Orientation” on page 56.

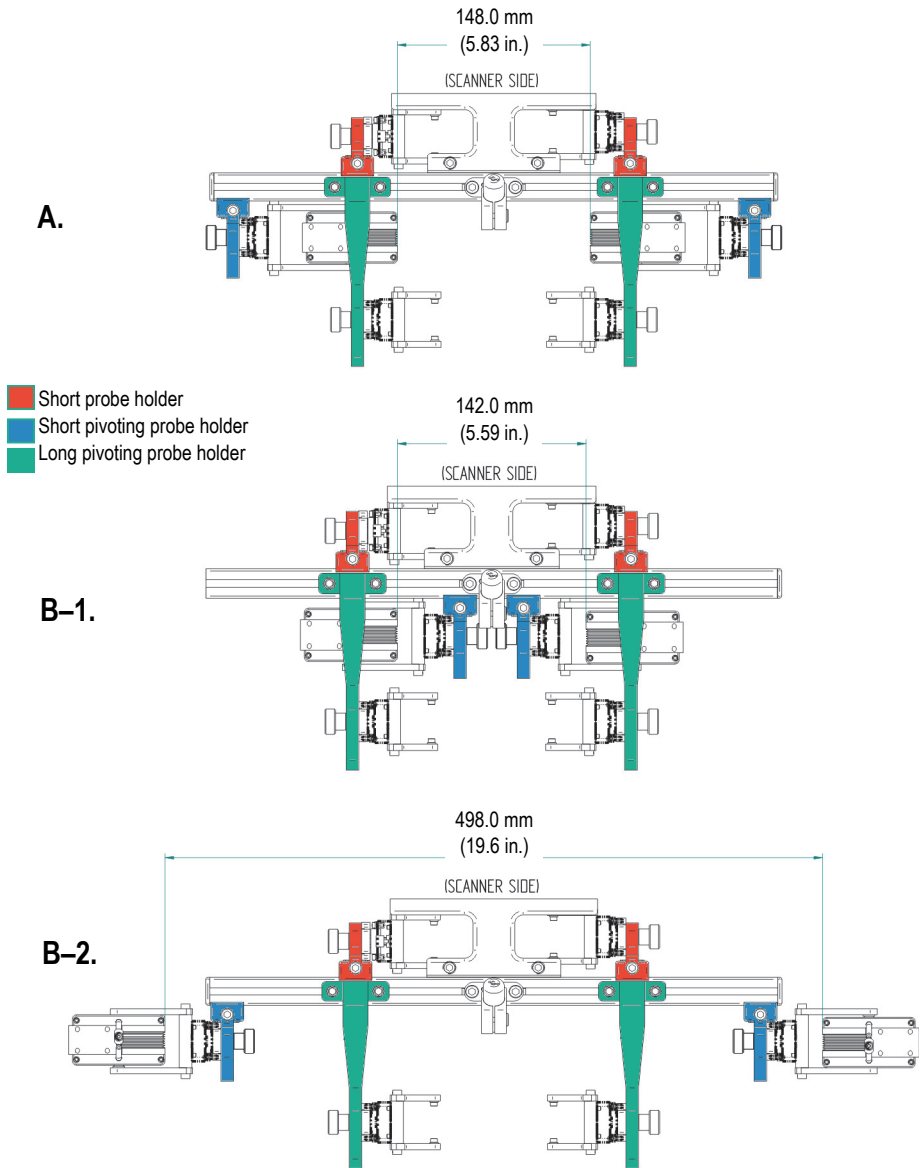

Figure 2-22 WeldROVER—PCS for SA12 wedge type

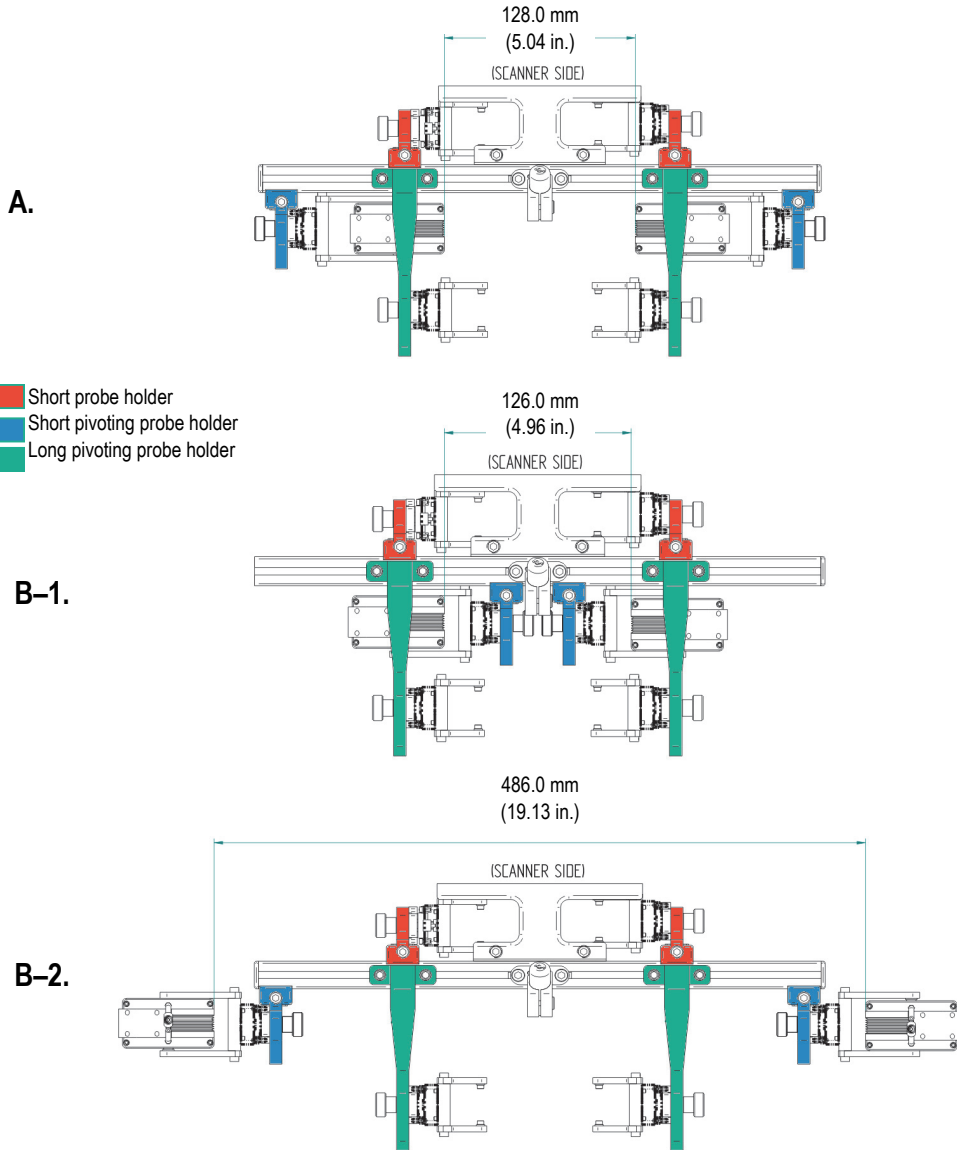

Figure 2-23 WeldROVER—PCS for SPWZ or SA14 wedge types

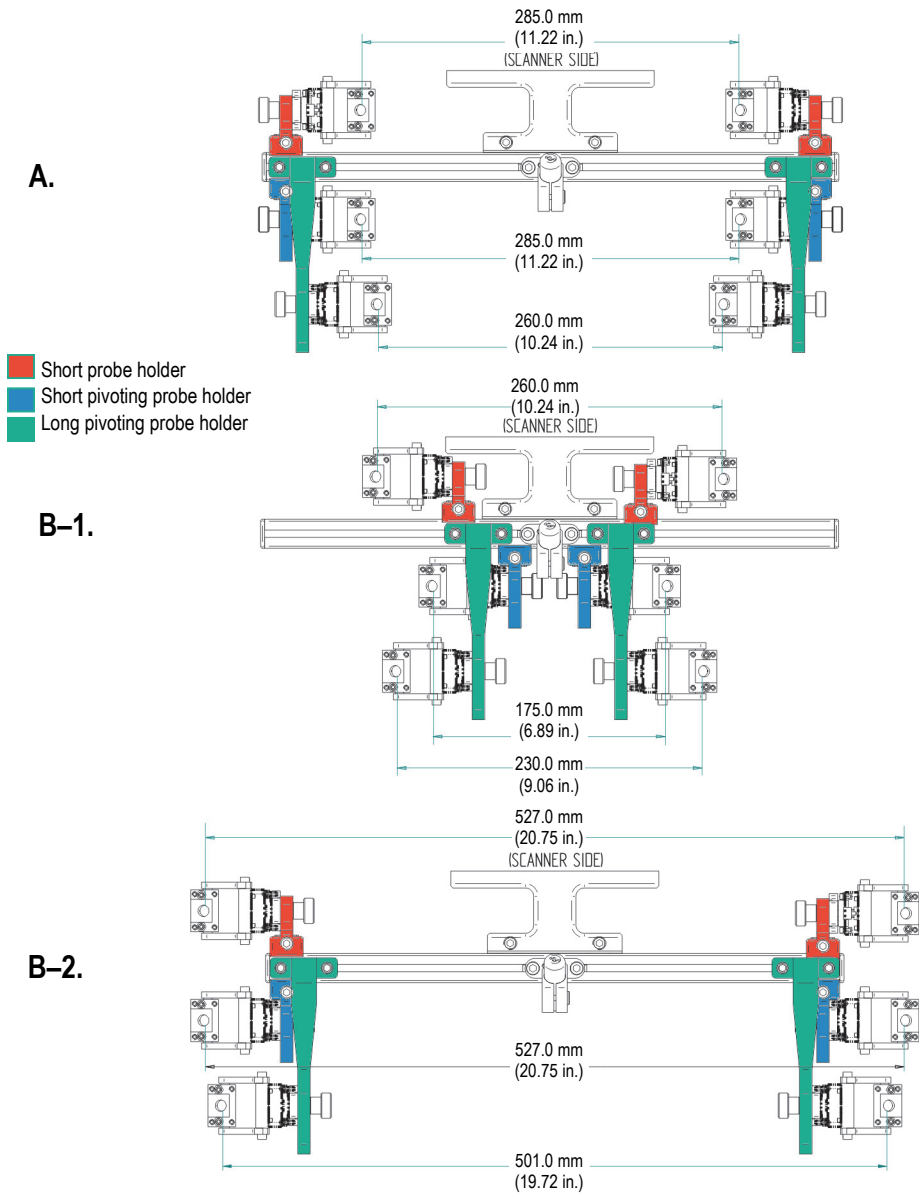

Figure 2-24 WeldROVER—PCS for TOFD wedge type

2.2.7 Yoke Orientation

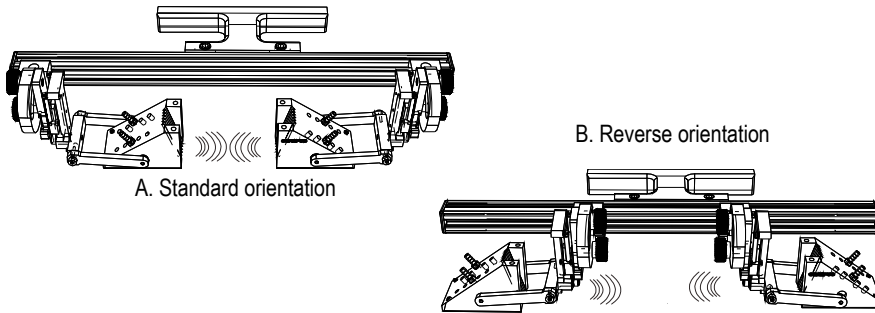

Figure 2-25 WeldROVER—yoke orientation

To change the orientation of the yokes

Based on standard configuration A in Figure 2-25 on page 56:

1. Remove the two plastic caps from the frame bar.
2. Loosen one of the two probe holder assemblies—this is referred to as **Probe assembly A** (see “To install or remove a probe holder” on page 43).
3. Slide out **Probe assembly A** and remove it from the frame bar.
4. Loosen the other probe holder assembly—**Probe assembly B**—from the frame bar.
5. Slide **Probe assembly B** to the opposite end of the frame bar.
6. Re-install **Probe assembly A** onto the first end of the frame bar (the previous location of **Probe assembly B**).
7. For each wedge:
 - a) Loosen one of the yoke arm screws to disengage it from the wedge.
 - b) If necessary, change the two yoke arms according to the PCS configuration found in Table 2 on page 51.
 - c) Remove the wedge from the yoke.
 - d) Reverse the wedge orientation.
 - e) Reinstall the wedge on the yoke.
 - f) Re-tighten the yoke arm on the SLA.

3. Preparation for an Inspection

WeldROVER inspection preparation requires the following types of actions:

- Installing the WeldROVER onto the ferromagnetic surface (page 57)
- Adapting the WeldROVER to the inspection surface (page 58)
- Removing the WeldROVER from the inspection surface (page 58)
- Cleaning the magnetic wheels (page 63)

3.1 WeldROVER Manipulation on Ferromagnetic Surfaces

This section contains the procedures recommended by Evident for manipulating the WeldROVER scanner over ferromagnetic inspection surfaces.

To install the WeldROVER onto a ferromagnetic surface

1. Grab the WeldROVER handle with one hand, and the steering lever with the other hand (when the steering lever is installed at the back of the scanner).
2. Check to make sure that your feet have a good grip on the floor, and then lift and steadily hold the scanner.
3. Brace yourself to control the anticipated magnetic attraction forces between the magnetic wheels and the inspection surface.
4. Slowly step forward, and proceed as follows to install the scanner over the weld to be inspected (use the laser beam to guide you):
 - a) Place the back wheels onto the surface to be inspected.
 - b) Ensure that all wedges are correctly positioned.
 - c) Lower the scanner until the front wheels touch the surface.

To remove the WeldROVER from a ferromagnetic surface

1. Grab the WeldROVER handle with one hand, and the steering lever with the other hand (when the steering lever is installed at the back of the scanner).
2. Using the back wheels as a pivot, lift the handle while pushing down on the steering lever.
This motion detaches the front wheels from the inspection surface.
3. Continue the lifting and pushing motions to use the scanner's frame as a lever.
This motion detaches the back wheels from the inspection surface.



CAUTION



Be careful when approaching a ferromagnetic surface with the WeldROVER. The wheels' magnetic force is strong and the scanner will be attracted by the surface without warning. Ensure that your feet have a solid grip on the ground. Use a rubber carpet when the floor is wet and slippery.

3.2 Adaptation to the Inspection Surface

In order to perform quality inspections, the wedges must maintain permanent contact with the surface being inspected. This is achieved with the spring-loaded arms (SLA). However, the SLAs must have enough displacement clearance to maintain contact. Precise adjustments of the probe-holder assemblies are required to ensure the correct clearance.

To adapt the WeldROVER to the inspection surface

1. Choose the correct inspection configuration for the scanner (see "Configurations" on page 43).
2. Install all probe holders required for the inspection, if this has not already been done (see "To install or remove a probe holder" on page 43).
3. Install the SLAs, yokes, probes, and wedges.
4. Check the magnetic wheels and, if necessary, remove any debris (see "To clean the magnetic wheels" on page 64).

5. Place the WeldROVER at the approximate, desired inspection position for the weld to be inspected (see “To install the WeldROVER onto a ferromagnetic surface” on page 57).
6. Adjust the position of the laser guide (see “To adjust the position of the laser guide” on page 39).
7. Use the laser guide to align the WeldROVER, and precisely position it parallel to the weld to be inspected (see “To align the WeldROVER with the weld” on page 66).
8. Adjust the position of the probe holders on the weld to be inspected.
9. Tighten the probe-holder screws.
10. Adjust the angle of the probe-holder arms (see “To adjust the angle of the probe-holder arms” on page 59).
11. If necessary, change the height of the SLAs (see “To adjust the height of the SLA” on page 60).
12. Adjust the SLA angle to set all SLAs perpendicular to the surface (see “To adjust the angle of the SLAs” on page 61).

IMPORTANT

The SLAs must have enough displacement clearance to maintain contact with the surface being inspected.

To adjust the angle of the probe-holder arms

1. Place the WeldROVER onto the surface to be inspected (see “To install the WeldROVER onto a ferromagnetic surface” on page 57).

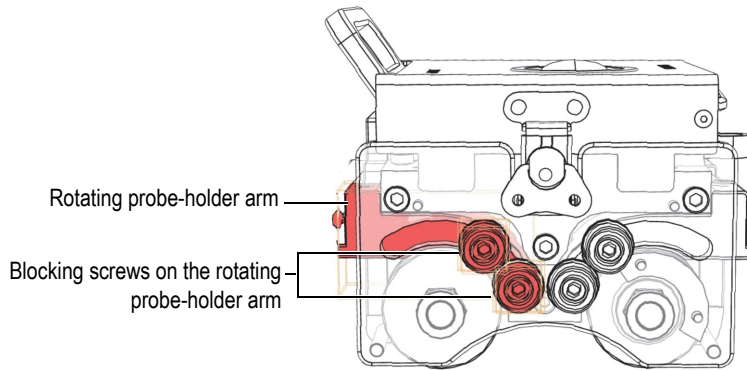

Figure 3-1 WeldROVER—Rotating probe-holder arm

2. Loosen the blocking screws on the rotating probe-holder arms (Figure 3-1 on page 60).
3. Adjust the angle of the rotating probe-holder arms.
4. Adjust the height of the SLAs (see “To adjust the height of the SLA” on page 60).
5. When all wedges properly contact the surface, verify the displacement of the SLAs. The SLAs must have enough displacement clearance. If this is not the case, repeat steps 3 to 5 until proper contact is made, and then proceed with step 6.
6. Tighten the blocking screws on the rotating probe-holder arms.

To adjust the height of the SLA

The SLAs have two height positions: high and low (Figure 3-2 on page 61):

- If a SLA is compressed too much, it must be raised.
- If a SLA is not compressed enough, it must be lowered.

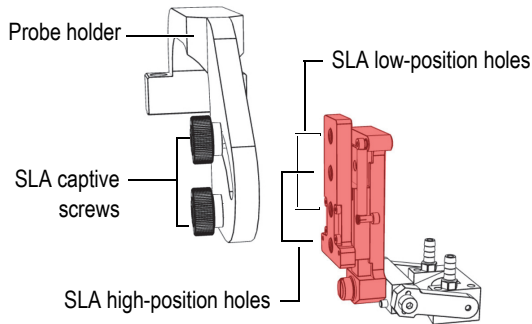

Figure 3-2 WeldROVER—two height positions for the SLA

1. Unscrew the two SLA captive screws.
2. Change the position of the SLA.
3. Tighten the two SLA captive screws.

TIP

To more easily remove the captive screws, do not try to completely unscrew one before the other. Instead, alternate between the two screws. You can also unscrew them simultaneously.

IMPORTANT

The SLAs must have enough displacement clearance to maintain contact with the surface being inspected.

To adjust the angle of the SLAs

1. Adjust the angle of the probe-holder arms (see “To adjust the angle of the probe-holder arms” on page 59).
The wedge should now be in contact with the surface to be inspected, and the angle between the SLA and the yoke needs to be adjusted to make it as close as possible to 90° (Figure 3-3 on page 62). When the adjustment is correct, the

springs of the SLA ensure a permanent contact between the wedge and the surface to be inspected.

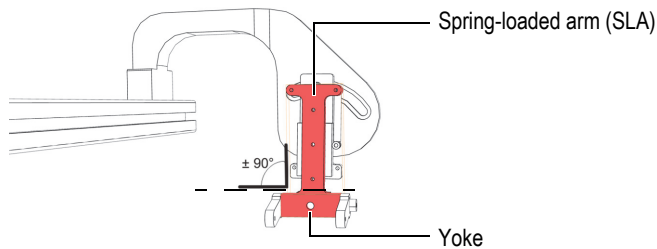

Figure 3-3 WeldROVER—Approximate 90° angle between the SLA and the yoke

2. Loosen the two captive screws on the SLA.

TIP

For an easier manipulation of the captive screws, do not try to unscrew one and then the other. Instead, alternate between the two screws. You can also unscrew them simultaneously.

3. Tilt the SLA to the left or to the right until the angle between the SLA and the yoke is 90°.
4. Tighten the two captive screws.
5. Repeat step 1 to step 4 for each SLA.

IMPORTANT

Always check to make sure that wedges that face each other are correctly aligned.

3.3 Cleaning the Magnetic Wheels

As detailed in “Magnetic Wheels and Related Safety Information” on page 29, the magnetic wheels are strongly attracted to ferromagnetic materials. Therefore, to avoid injuries, you must be careful when cleaning the wheels.



WARNING



Before every use of the WeldROVER, ensure that no ferromagnetic object has become attached to the wheels. Foreign objects on the wheels can cause the scanner to deviate from its path and decrease its stability. The magnetic bond between the magnetic wheels and the surface may become weak enough to cause the scanner to break away and fall down. To avoid the risk of injuries and equipment damage, always use a lanyard for safety.



WARNING



The WeldROVER generates a magnetic field strong enough to affect pace makers, watches, and other sensitive electronic devices, and anyone wearing or depending on such devices should keep a safe distance away from the WeldROVER to avoid the risk of serious injuries, or death, and damaged devices. This magnetic field can also demagnetize credit cards, magnetic ID (identification) badges, etc.

Cleaning frequency:

- Before every inspection session

Required accessories and tools:

- Stainless steel brush (provided, Evident part number 54AP0042)
- A clean cloth
- Work gloves

Prerequisite actions to perform:

- Connect the remote control to the MCDC-01.
- Connect the motorized scanner to the MCDC-01.

- Connect the MCDC-01 power supply to an appropriate AC power source.

To clean the magnetic wheels

1. Put on your work gloves.
2. Place the scanner wheels in the up position on a stable working surface.
3. Turn the power on.
4. On the remote control, set the speed to position 5.
5. Press the forward button to set the wheels in a continuous motion (see “To move the WeldROVER continuously forward or backward” on page 66).
6. Use the stainless steel brush to remove any ferromagnetic-material residue from the wheel (Figure 3-4 on page 64).
7. Hold the clean cloth against the wheel to remove small particles.
8. Repeat steps 6 and 7 for each remaining wheel.
9. Press any remote control button to stop the wheels’ motion.

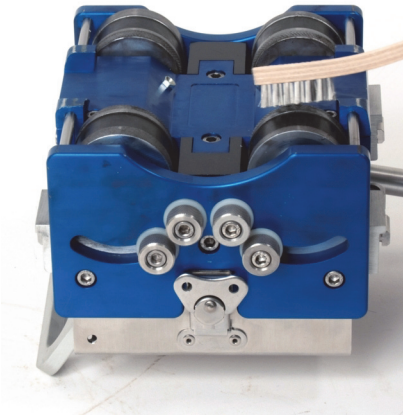

Figure 3-4 WeldROVER—Stainless steel brush on the wheel

4. WeldROVER Operation

Once the WeldROVER has been correctly prepared, scanning a weld becomes a simple operation; this lets you focus on moving the scanner along the inspection path.

4.1 Basic Operations

WeldROVER inspections require the following operations:

- Jogging the scanner forward or backward (page 65).
- Moving the scanner forward or backward continuously (page 66).
- Aligning the scanner with the weld (page 66).
- Determining the speed of the acquisition (page 67).



WARNING

To avoid the risk of serious injuries, or death, and equipment damage, always use a lanyard for safety. The scanner must always be secured to a proper lanyard when being used at a height higher than 2 meters.

To jog the WeldROVER forward or backward

1. On the remote control, press the corresponding button halfway down (Figure 4-1 on page 66).
2. Release the button to stop the motion.

To move the WeldROVER continuously forward or backward

1. On the remote control, press the corresponding button completely down (Figure 4-1 on page 66).
2. Press any button to stop the motion.

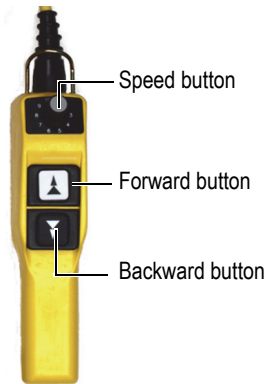

Figure 4-1 WeldROVER—Remote control for MCDC-01

To align the WeldROVER with the weld

1. Place the WeldROVER on the surface being inspected so that the laser beam is aligned with the weld (see “To install the WeldROVER onto a ferromagnetic surface” on page 57).
2. On the remote control, press the forward button to jog the scanner forward (see “Remote Control” on page 26).
3. To steer the WeldROVER, apply pressure against either side of the steering lever as follows:
 - ◆ When the scanner is heading towards the left, apply pressure towards the left and vice versa.
4. Repeat step 3 until the laser guide correctly follows the weld to be inspected.
5. Drive the scanner back to its starting position to recover the umbilical.

The scanner should now be aligned correctly, parallel to the weld.

NOTE

If the steering lever is at the front of the scanner—or if you prefer moving the WeldROVER backward—reverse the pressure on the lever. For example, if the scanner is heading left, push on the steering lever towards the right.

**WARNING**

To avoid the risk of serious injuries, or death, and equipment damage, ensure that the surface to be inspected is a continuous ferromagnetic material surface. If there is an interruption in the ferromagnetic surface, the WeldROVER can break away and fall down. Always use a lanyard for safety.

To determine the speed of the acquisition

Evident recommends that you perform several tests to determine the optimal speed of the scanner. For each application, the scanner speed should be optimized according to the acquisition rate of the acquisition unit.

1. Set the speed on the remote control to position 1 (5 mm/s).
 2. Press the corresponding button to move the scanner forward.
 3. Progressively increase the speed of the scanner until the acquisition unit display is missing data.
 4. Slow down the scanner by one or two positions on the speed button.
This is the optimal scanner speed for your acquisition rate.
-

**WARNING**

To avoid the risk of serious injuries, or death, and equipment damage, before the inspection begins, ensure that the umbilical is long enough to cover the complete surface to be inspected. Also, be sure that the movement of the umbilical does not interfere with personnel or any objects around.



WARNING

To avoid the risk of serious injuries, or death, and equipment damage, before launching the WeldROVER forward for the inspection, verify that the inspection path is clear of debris or obstruction.

4.2 Performing an Inspection with the WeldROVER

Before driving the WeldROVER along a weld, you must make sure that the following preparations have been made and precautions have been taken:

1. You have read, and you fully understand the safety notice in “Magnetic Wheels and Related Safety Information” on page 29.
2. The acquisition unit—OmniScan, or TomoScan FOCUS LT— has been properly set up (refer to the *User’s Manual* of your acquisition unit for details).
3. The required connections (water tube, probe cables, control cable, etc.) have been completed (see “To connect the umbilical to the WeldROVER” on page 36).
4. You have chosen and completed the most suitable WeldROVER configuration for the pipe or the pressure vessel to be inspected (for examples of configurations, see “Configurations” on page 43).
5. The proper combination of probes for the type of inspection has been selected, and has been installed.
6. The laser guide has been properly positioned, according to the scanner and probe configuration (see “To adjust the position of the laser guide” on page 39).
7. The WeldROVER has been adapted to the surface to be inspected (see “To adapt the WeldROVER to the inspection surface” on page 58).
8. The WeldROVER is aligned with the weld (see “To align the WeldROVER with the weld” on page 66).
9. The optimal speed of the scanner has been determined according to the specific acquisition rate of the instrument, and has been set on the remote control (see “To determine the speed of the acquisition” on page 67).
10. The inspection path is clear of any debris or obstruction.
11. You have double-checked that the pipe or the pressure vessel to be inspected provides a continuous ferromagnetic surface.

12. You have double-checked that the WeldROVER is secured with an adequate safety lanyard.

To drive the WeldROVER along a weld

1. Ensure that there is enough couplant for the inspection, and that the couplant flow is steady.



CAUTION

Using water as a couplant can make the floor slippery. To avoid the risk of injuries and equipment damage, be sure to have a solid grip on the floor. Use a rubber carpet if necessary.

-
2. Press the corresponding button on the remote control to initiate the WeldROVER forward motion.
 3. On large pipes or pressure vessels, periodically verify that the weld being inspected remains aligned with the laser beam. Correct the WeldROVER's direction, if required, using the steering lever.
 4. When the scan is finished, press any button on the remote control to stop the scanner's motion.
 5. If a flaw is detected during the inspection process, you can jog backward or forward to the exact location of the flaw for a more thorough examination.
 6. Once the surface have been fully covered by the WeldROVER, drive the scanner back to its starting position in order to recover the umbilical.

5. Accessories and Spare Parts

This chapter contains details on the WeldROVER system components, including the transport case, accessories, and spare parts.

5.1 WeldROVER Transport Case

The WeldROVER comes standard with a hard carrying case for transport (Figure 5-1 on page 71).

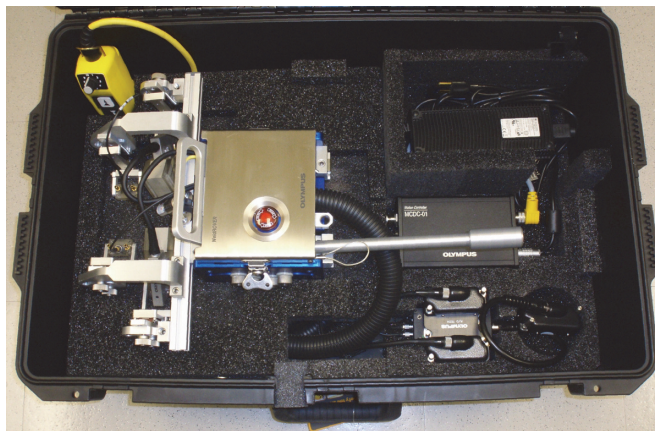

Figure 5-1 WeldROVER—standard hard carrying case

An optional hard carrying case for instruments and accessories is also available (Evident part number: WELDROVER-A-ICASE) [see Figure 5-2 on page 72]. This optional case contains removable trays that can hold different acquisition units or accessories.

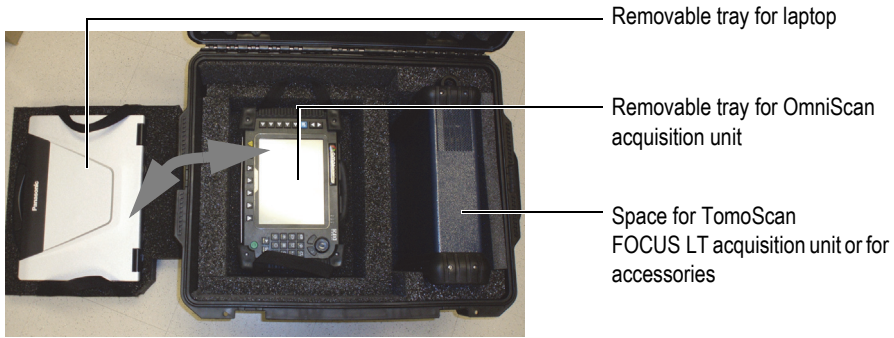

Figure 5-2 WeldROVER—optional hard carrying case

The removable trays in the optional case are also designed for use in the WeldROVER standard hard carrying case. The standard case's wheels, opening for the umbilical, and removable trays allow you to easily transform it into a field-ready mobile workstation without having to unplug any cables other than the AC power cable.



Figure 5-3 WeldROVER hard carrying case—mobile workstation configuration



Figure 5-4 WeldROVER—transporting the system in the field

5.2 WeldROVER System Components

The main components of the WeldROVER system are shown in Figure 5-5 on page 73, and corresponding Evident part numbers are listed in Table 3 on page 74.

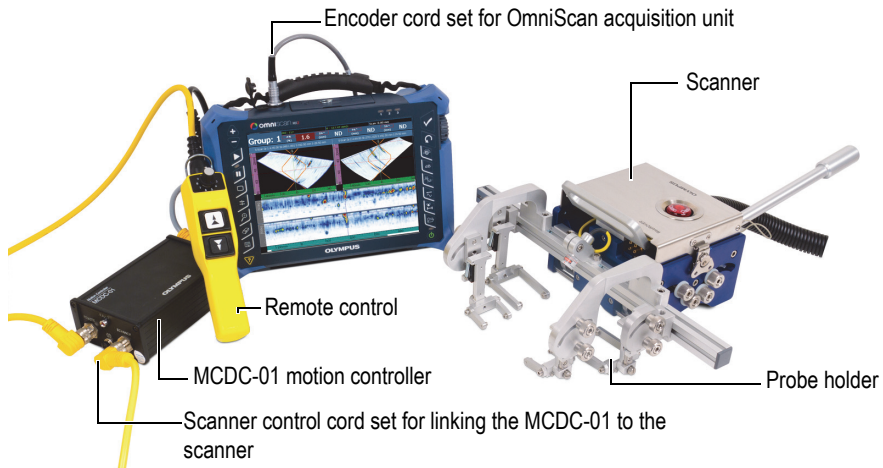

Figure 5-5 WeldROVER system—Principal components

Table 3 WeldROVER part numbers for principal components

Component	Part number	Order number	Description
Power supply	EKIX0162A	U8905948	Input voltage: 100 VAC or 240 VAC, auto-switching, 43 Hz to 53 Hz
MCDC-01	AAIX0460	U8906418	Motion controller
Encoder out cable	WELDROVER-SP-LCABLE	U8775311	Links the MCDC-01 to an OmniScan MX2 or SX acquisition unit (1.5 m)
Remote control	WELDROVER-A-REMOTE	U8775126	Remote control with 5 m cable
Scanner	ACIX1249	U8906417	WeldROVER motorized scanner (without probe holder)
Scanner control cord set	WELDROVER-SP-CAB01	U8840175	Links the MCDC-01 to the WeldROVER scanner (5 m)
Probe holder package	ABIX0637	N/A	Standard probe holder package for 2 pairs of probes including the laser module (probes not included)
Transport case	WeldRover-SP-Scase	U8775192	WeldROVER hard carrying case

**WARNING**

To avoid the risk of serious injuries, or death, and equipment damage, only use the power supply delivered with your WeldROVER system. Failure to comply can also invalidate your warranty.

5.3 Yokes

Figure 5-6 on page 75 and Table 4 on page 75 provide ordering information for yokes. Yoke dimensions depend on the wedge model used.

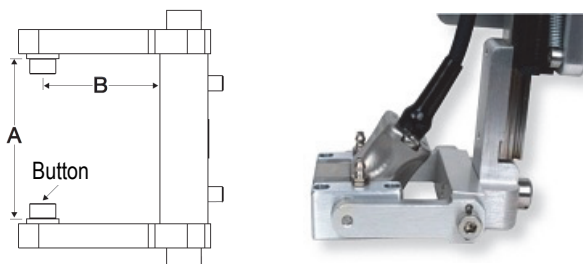

Figure 5-6 Yoke geometry

Table 4 Replacement yokes

Part Number	Item Number	Wedge compliance	Button OD (mm)	A (mm)	B (mm)
Standard yokes					
ADIX689 ^a	U8775048	ST1, ST2, SPE1, SPE2, SPE3, SA0	5	31.75	23.5
ADIX655 ^b	U8775047	SA1, SA2, SA10, SA11, SA12, SPWZ3, SNW1-AQ25 (WR), SNW3-AQ25	8	40	55
Other yokes					
ADIX612	U8775046	SA10 and SA11	8	40	38
ADIX1354	U8775187	SPWZ1 and SA14 (in reverse position)	8	40	46
ADIX1082	U8780194	SPWZ1, SA14, RexoFORM, SNW3-AQ25-WR	8	40	65
ADIX853	U8775055	SA1-L (lateral)	8	45	60
ADIX846	U8779096	SA3	8	50	55
ADIX893	U8775084	SA4, SA5, and HydroFORM-A-LiteHolder	8	55	55
ADIX908	U8779097	Water wedge	8	50	65
ADIX870	U8775056	Creeping wave probe holder (ADIX1129)[U8775080]	5	40	23
ADIX1325	U8775132	SNW1	8	31.75	55
ADIX1482	U8775165	SNW2	8	31.75	23.5
ADIX1481	U8775164	SNW3	8	31.75	65

- a. Standard yoke for TOFD-P/E probe mounting.
b. Standard yoke for phased array probe mounting.

5.4 Couplant-Feed Units

Couplant can be supplied to wedges by either an electric or a manual pump (Table 5 on page 76).

Table 5 Couplant-feed units

Part number	Item number	Description
CFU03	U8780008	Electric couplant-feed unit. 3.78 L/min at 414 kPa (1 GPM at 60 psi) 100 VAC/240 VAC
CFU05	U8780009	Electric couplant-feed unit with suction capability. Same operating specification as CFU03.
WTR-SPRAYER-8L	U8775001	8 L manual water pump with irrigation tubes and fittings.

5.5 Connector Reference

WeldROVER models sold after July 2013 come standard with the LEMO connector, which is compatible with the OmniScan MX2 and SX instruments. If the WeldROVER is used with a different instrument, an optional adaptor is required (Table 6 on page 76).

Table 6 Required encoder cable adaptor

Scanner Connector	Instrument			
	OmniScan MX	OmniScan MX2	OmniScan SX	TomoScan FOCUS LT
LEMO (from July 2013 onward)	OMNI-A-ADP27 (EWIX902) [U8780329]	—	—	C1-LF-BXM-0.3M [U8769010]
DE15 (Prior to July 2013)	—	OMNI-A2-ADP20 [U8775201]	OMNI-A2-ADP20 [U8775201]	C1-DE15F-BXM-0.30M [U8767107]

5.6 WeldROVER Scanner Spare Parts

An exploded view of the WeldROVER scanner parts is shown in Figure 5-7 on page 77, and the spare part numbers are listed in Table 7 on page 78.

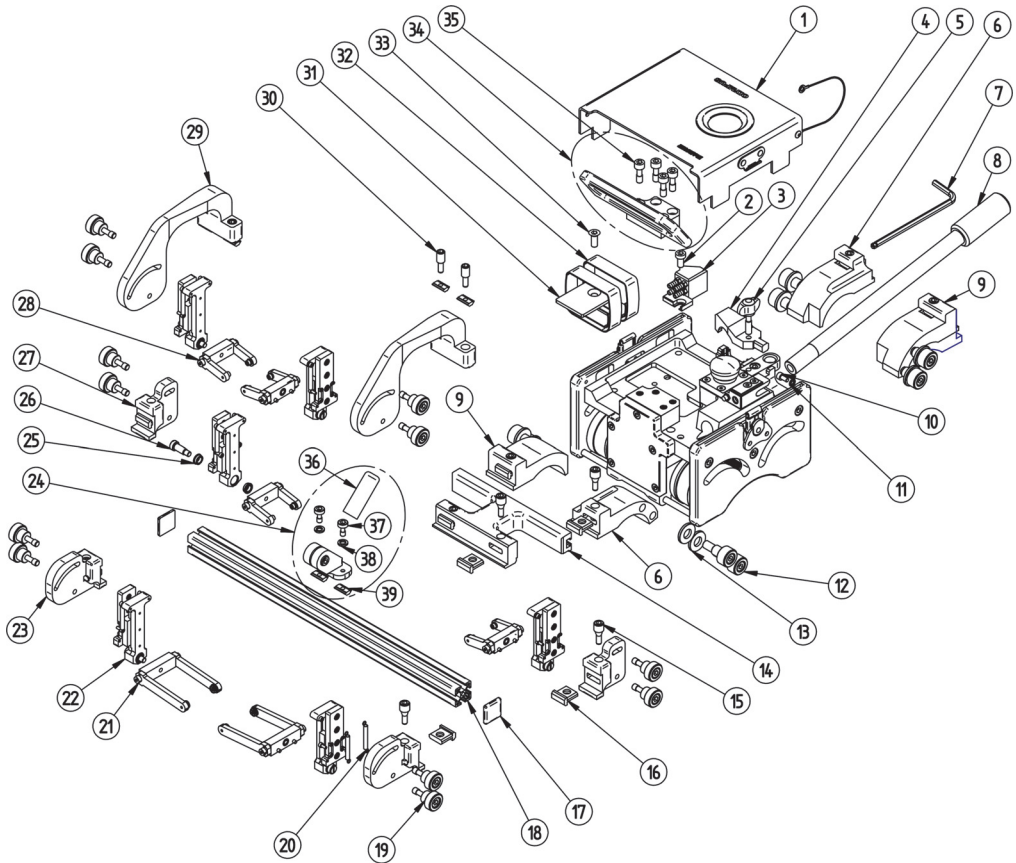

Figure 5-7 WeldROVER scanner exploded view

Table 7 WeldROVER scanner spare parts list

Number	Quantity	Part number	Order number	Description
1	1	MSIX1631	N/A	Protective cover assembly
2	1	28OA0052	N/A	Manifold screw M6 × 12 mm hex., stainless
3	1	ADIX1191	N/A	Water manifold
4	1	MQIV3339	N/A	Umbilical clamp
5	1	MKIX1197	N/A	Clamp thumb screw M6 × 25 mm
6	2	AEIX0472	N/A	Rotating arm with corner break
7	1	54CD0116	U8906659	Hexagonal key, 5 mm
8	1	MQIV1776	U8908862	Steering lever
9	2	AEIX0452	N/A	Probe holder arm
10	1	28MA0044	U8906821	Screw M4 × 8 mm hex., stainless
11	1	28ME0002	U8902446	Spring washer M4, stainless
12	8	MSIX1728	U8906666	Knob for rotating arms
13	8	28QE0147	U8906658	Knob flat washer M10 nylon
14	1	ADIX1280	U8150300	Offset bracket assembly with nuts and screws
15	10	MKIX950	U8906562	Taper hex. S-set screw M10 × 10 mm
16	10	MQIV3714	U8906563	90° Dovetail nut
17	6	25GA0189	U8906556	Frame bar cap, 22 mm × 22 mm
18	1	Weldrover -SP- Fbar430	U8779175	Frame bar, 430 mm
19	12	MSIX1655	U8906557	Yoke knob assembly
20	12	25CC0042	U8906541	Spring for SLA
21	2	ADIX655	U8775047	Phased array yoke 5° 40 mm × 55 mm
22	6	WELDRO VER-A- SLA	U8775125	SLA support assembly

Table 7 WeldROVER scanner spare parts list (continued)

Number	Quantity	Part number	Order number	Description
23	2	ADIX1222	U8906558	Short rotating probe holder assembly with nuts and screws
24	1	AAIX0466	N/A	Laser guide assembly with holder
25	12	25BB0116	U8775110	Bearing for SLA
26	6	MKUX567	U8775041	Shoulder screw for SLA
27	2	ADIX1298	U8906559	Short probe holder assembly with nuts and screws
28	4	ADIX689	U8775048	TOFD yoke 10° 31.75 mm × 23.5 mm
29	2	ADIX1223	U8775191	Long pivoting probe holder assembly with nuts and screws
30	4	MKIX1103	U8906664	Hex. set screw M10 modified
31	1	MQIV1667	N/A	Velcro plate
32	2	MKIX955	N/A	Velcro strap
33	1	28OA0008	U8830211	Velcro screw M6 × 16 mm hex. Flat. stainless
34	1	ADIX1286	N/A	Handle assembly
35	4	MKIX1160	U8830260	Handle captive screw M10 × 18 mm hex. stainless
36	1	WELDRO VER-A- LASER	U8775124	Laser module and cable
37	2	MKIX1204	U8831979	Laser captive screw M6 × 12 mm hex. stainless
38	2	28OE0006	U8150203	Laser spring washer M6, stainless
39	6	25GA0009	U8900310	Dovetail M5 nut
NOT SHOWN	2	Weldrover -SP- FBar200	U8831641	Frame bar, 200 mm
NOT SHOWN	2	ADIX1082	U8780194	Yoke 5° 40 mm × 65 mm (for SPWZ1-IHC wedges)

Table 7 WeldROVER scanner spare parts list (continued)

Number	Quantity	Part number	Order number	Description
NOT SHOWN	1	KITX0202	N/A	Irrigation kit
NOT SHOWN	1	54EC0282	U8906531	Draw-in tool
NOT SHOWN	1	OPTX0719	U8779095	5 m divisible cable conduit 24.2 mm ID
NOT SHOWN	4	MQIV541	U8906665	4 in. Velcro strap

6. Technical Specifications

This chapter lists the technical specifications of the WeldROVER system.

Table 8 WeldROVER specifications

Specification	Value
Scanner speed	5 mm to 50 mm per second (0.20 in. to 1.97 in. per second)
Encoder resolution	2100 steps/mm (typical)
Power consumption	90 W
Maximum input current	4.0 A
Voltage input	24 VDC
Front wheel magnetic force	37.45 kg /wheel (82.5 lb /wheel)
Back wheel magnetic force	29.48 kg /wheel (65.0 lb /wheel)
Operating temperature	5 °C to 40 °C (41 °F to 104 °F)
Storage temperature	-20 °C to 60 °C (-4 °F to 140 °F)
Operating altitude	2000 m max. (6561 ft. max.)
Outdoor use	Yes
Wet location	Yes
Pollution level	1
IP rating	Waterproof— designed to meet IP65
Relative humidity (RH)	85 %, noncondensing
Manifold max. pressure	48 kPa (7 psi)

Table 9 WeldROVER—Power supply specifications

Specification	Value
Power output	150 W
Maximum output current	6.25 A
Voltage input	100 VAC to 240 VAC, 47 Hz to 63 Hz
Voltage output	24 VDC

Table 10 WeldROVER scanner—physical characteristics

Component	Length mm (in.)	Width mm (in.)	Height mm (in.)	Weight kg (lb)
Scanner with long bar and 6 probes	430 (17)	340 (14)	175 (7)	12.0 (25) ^a
Scanner with small bars and 4 probes	380 (15)	200 (8)	175 (7)	11.0 (24) ^a
MCDC-01 motion controller	175 (7)	110 (4)	60 (2)	1.5 (3)
Power supply	200 (8)	85 (3)	50 (2)	1.0 (2)
Remote control	230 (9)	50 (2)	90 (3)	0.8 (2)

a. The total weight of the scanner and its parts must not exceed 13.5 kg (29.76 lb).

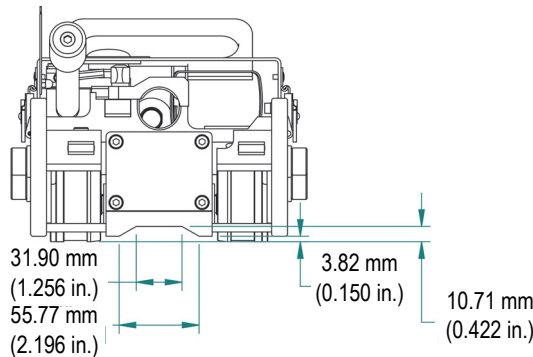
**Figure 6-1 WeldROVER scanner—weld cap clearance**

7. WeldROVER System Connectors Description

The WeldROVER system requires various cables and connectors for linking components. Most connectors are for the MCDC-01 and the WeldROVER scanner. This chapter lists the WeldROVER system connectors, including description, part number, mating cable, and pinout.

7.1 MCDC-01 connectors

The MCDC-01 motion controller contains the following five connectors (see “Motion Controller” on page 27 and Figure 7-1 on page 84):

- Power supply connector
- RS-232 communication port
- ENCODER OUT connector
- REMOTE connector
- SCANNER connector

The RS-232 communication port is reserved for advanced diagnosis by Evident’ specialized technicians.

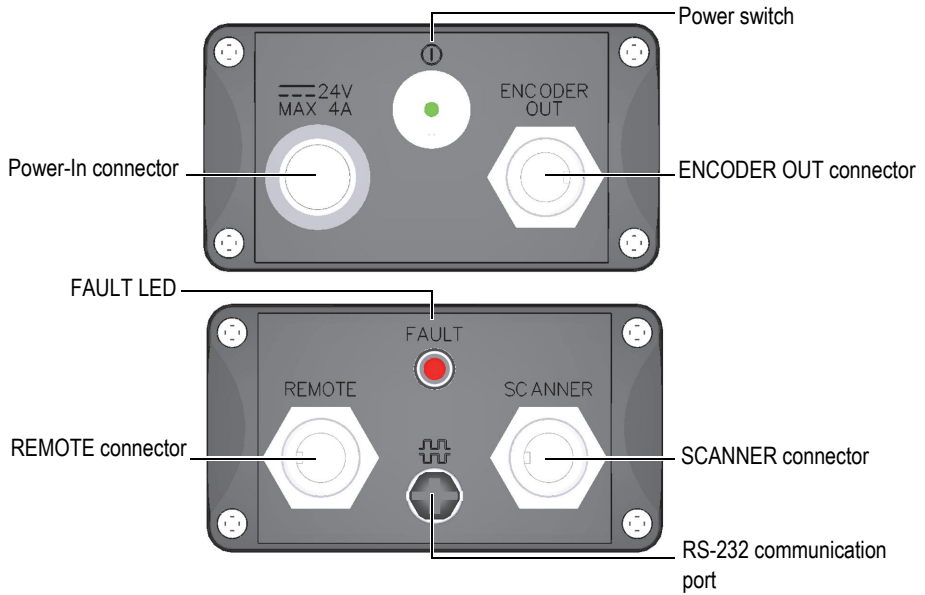



Figure 7-1 MCDC-01—connector identification

7.1.1 Power-In Connector

Location

See Figure 7-1 on page 84.

Label

 24V MAX 4A

Description

Metal sealed, hermaphroditic connector
AWG 20, 1700 V (AC), 2400 V (DC), 15 A (AC/DC)
IEC IP66

Manufacturer, number

LEMO, ERA.2E.304.CLL
Evident, 21AB5389

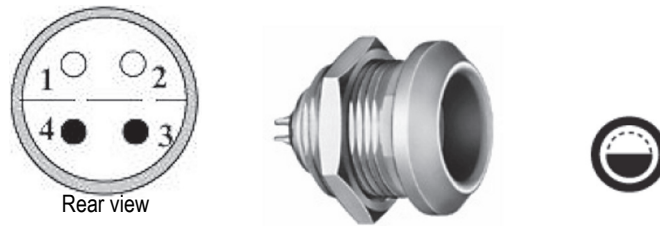

Figure 7-2 MCDC-01 – Power-In connector

Suggested mating connector

LEMO, FFA.2E.304.CLAC60

Evident, 21AB5388



Figure 7-3 MCDC-01 – Suggested mating connector for power supply

Table 11 MCDC-01 – Pinout for the power supply's mating cord set

Evident part number	Pin number	Suggested mating cord set color	Name
EKIX0162 (Complete power supply assembly)	1	Black	GND
	2	Red	+24 V
	3	Red	+24 V
	4	Black	GND
	(shell)	Drain	Earth

7.1.2 Encoder Out Connector

Location

See Figure 7-1 on page 84.

Label

ENCODER OUT

Description

8-pin M-16 *versafast*, female connector
22 AWG, 105 °C,
125 VAC/VDC, 7 A
IEC IP67

Manufacturer, number

Turck Inc., BKFD 8-8-05/M18
Evident, 21AI5262

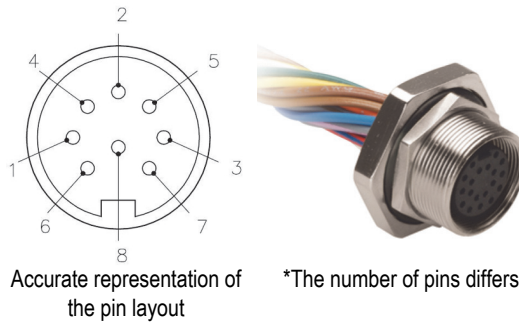

Figure 7-4 MCDC-01—Encoder Out connector

Suggested mating cord set

Turck Inc., BS 8-0
Evident, EWIX1427, 21AI5312



Figure 7-5 MCDC-01 – Encoder Out mating cord set

Table 12 MCDC-01 – Pinout for the Encoder Out mating cord set

Evident part number	Pin number	Suggested mating cord set color	Name
EWIX1427	1	White	RX
	2	Black	TX
	3	White	PHA
	4	Brown	PHB
	5	Orange	ACQEN
	6	Red	+5 V
	7	White	GND
	(Shell)	DRAIN	EARTH

Suggested mating cord set

LEMO, FGG.1K.316.CLAC60Z

Evident, EWIX1427, 21AB5436



Figure 7-6 OmniScan MX2 or SX—Encoder Out mating cord set

Table 13 OmniScan MX2 or SX—Pinout for Encoder Out mating cord set

Evident part number	Pin number	Suggested mating cord set color	Name
EWIX1427	2	Red	+5 V
	5	Orange	ACQEN
	9	White	PHA
	10	Brown	PHB
	14	Black	RX
	15	White	TX
	16	White	GND
	Case	DRAIN	EARTH

7.1.3 Remote Control Connector

Location

See Figure 7-1 on page 84.

Label

REMOTE

Description

12-pin M16 *versafast*, female connector
22 AWG, 105 °C,
125 VAC/VDC, 4 A
IEC IP67

Manufacturer, number

Turck Inc., BKFD 12-12-0.5/M18
Evident, 21AI0238

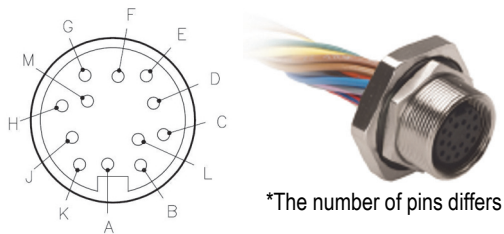

Figure 7-7 MCDC-01—Remote control connector

Suggested mating cord set

Turck Inc., BSWM 12-436-5/CSI1760

Evident, 60NA0332

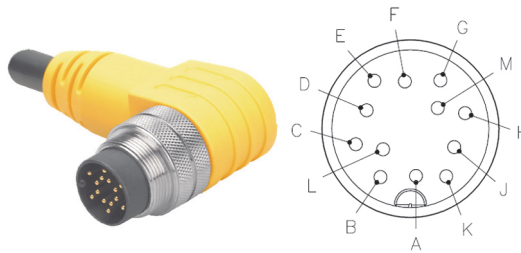

Figure 7-8 MCDC-01—Remote control mating connector

Table 14 MCDC-01—Pinout for remote controller's mating cord set

Evident part number	Pin number	Suggested mating cord set color	Name
60NA0332	A	Brown	GND
	B	Blue	AUTO
	C	White	UP
	D	Green	DOWN
	E	Yellow	SPARE
	F	DRAIN	FRAME
	G	Pink	10 V
	H	Red	5 V
	J	Black	GND
	K	Orange	FAULT
	L	Tan	AIN
	M	Violet	AGND

7.1.4 Scanner Connector

Location

See Figure 7-1 on page 84.

Label

SCANNER

Description

14-pin M16 *versafast*, female connector
 22 AWG, 105 °C,
 125 VAC/VDC, 3 A
 IEC IP67

Manufacturer, number

Turck Inc., BKFD 14-14-0.5/M18
 Evident, 21AI0237

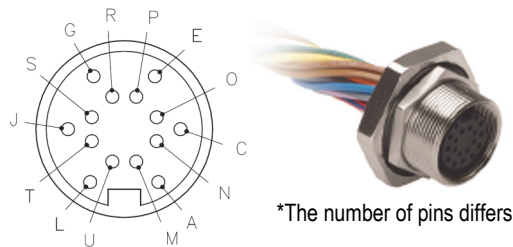

Figure 7-9 MCDC-01—Scanner connector

Suggested mating cord set

Turck Inc., BSWM BKM 14-436-5/CS11759
 Evident, 60NA0330

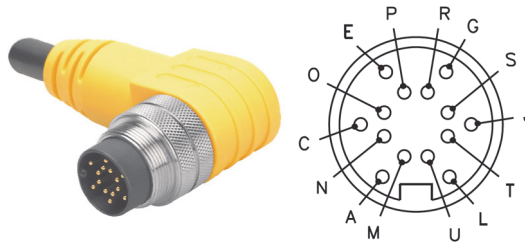

Figure 7-10 MCDC-01—Scanner mating cord set

Table 15 MCDC-01—Pinout for scanner connector's mating cord set

Evident part number	Pin number	Suggested mating cord set color	Name
60NA0330	A	Brown	LED
	C	Red/Blue	LASER
	E	Black	GND
	G	Pink	MOT+
	J	Green	MOT+
	L	Blue	MOT-
	M	Orange	MOT-
	N	Grey/Brown	ESTOP
	O	Violet	PHA+
	P	White	PHA-
	R	Red	+5 V
	S	DRAIN	EARTH
	T	Yellow	PHB+
	U	Tan	PHB-

7.1.5 RS-232 Communication Port

Location

See Figure 7-1 on page 84.

Label



Description

3-pin *picofast*, female connector
22 AWG, 80 °C,
125 V, 4 A
IEC IP67

Manufacturer, number

Turck Inc., WMFK 3F
Evident, 21AI0242

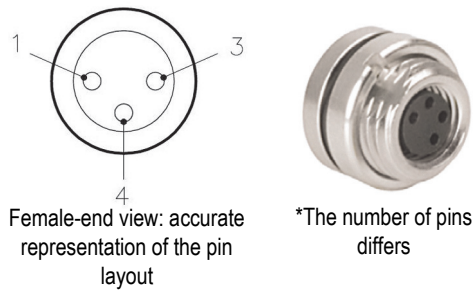

Figure 7-11 MCDC-01—RS-232 communication port

Suggested mating cord set

Turck Inc., PSW 3M-DB9F/CS11763
Evident, 60NA0334

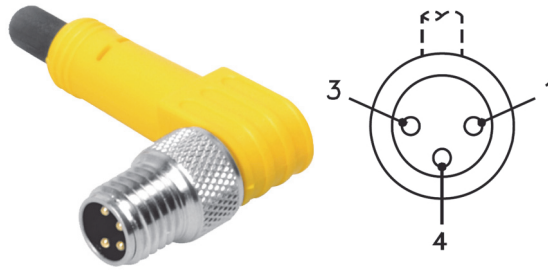

Figure 7-12 MCDC-01—RS-232 communication port mating cord set

Table 16 MCDC-01—Pinout for RS-232 communication port's mating cord set

Evident part number	Pin number	Suggested mating cord set color	Name
601NA0334	1	Black	AGND
	3	Blue	RXD
	4	Brown	TXD

Closure cap for RS-232 connector

picofast, closure cap

Closure cap manufacturer, number

Turck Inc., PSGM-CC

Evident, 21AI0243

7.2 WeldROVER Scanner Connectors

The WeldROVER scanner has two connectors under its protective cover: the laser guide connector and the control cable connector (Figure 7-13 on page 95).

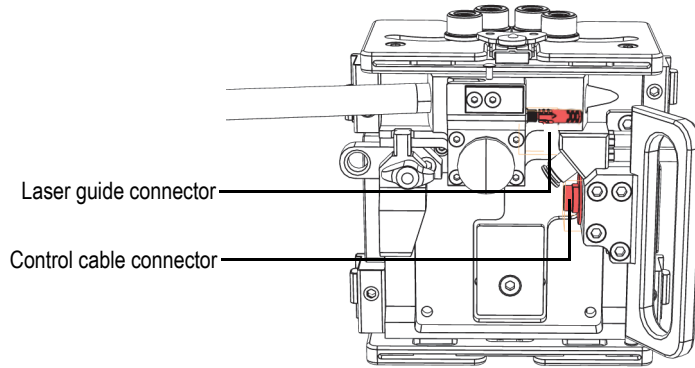

Figure 7-13 WeldROVER scanner—Connectors location

7.2.1 Control Connector

Location

On the scanner, under the protective cover (Figure 7-13 on page 95).

Label

None

Description

14-pin M16 *versafast*, female connector
 22 AWG, 105 °C,
 125 VAC/VDC, 3 A
 IEC IP67

Manufacturer, number

Turck Inc., BSF 14-14-0.5/M18
 Evident, 21AI0239

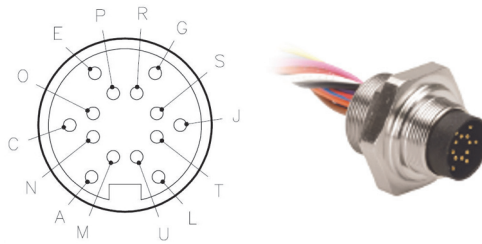

Figure 7-14 WeldROVER scanner—Control connector

Suggested mating cord set

Turck Inc., BSWM BKM 14-436-5/CS11759

Evident, 60NA0330

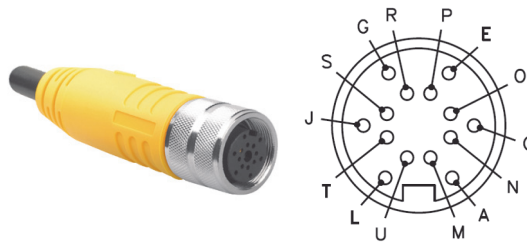

Figure 7-15 WeldROVER scanner—Control mating cable

Table 17 Scanner—Pinout for control connector’s mating cord set

Evident part number	Pin number	Suggested mating cord set color	Name
60NA0330	A	Brown	LED
	C	Red/Blue	LASER
	E	Black	GND
	G	Pink	MOT+
	J	Green	MOT+
	L	Blue	MOT-
	M	Orange	MOT-
	N	Gray/Brown	ESTOP
	O	Violet	PHA+
	P	White	PHA-
	R	Red	+5 V
	S	DRAIN	EARTH
	T	Yellow	PHB+
	U	Tan	PHB-

7.2.2 Laser Guide Connector

Location

On the scanner, under the protective cover (Figure 7-13 on page 95).

Label

None

Description

3-pin *pentafast*, female connector
 26 AWG, 80 °C, 125 V, 1 A
 IEC IP67

Manufacturer, number
 Turck Inc., VFK 3-0.2
 Evident, 21AI0235

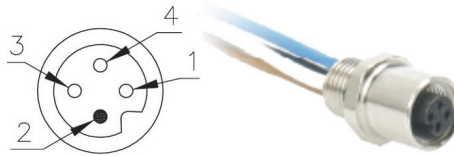

Figure 7-16 WeldROVER scanner—Laser guide connector

Suggested mating cord set
 Turck Inc., VSG 3M-0.5/S90
 Evident, 60NA0319



Figure 7-17 WeldROVER scanner—Laser guide mating connector

Table 18 Scanner—Pinout for laser guide’s mating cord set connector

Pin number	Suggested mating cord set color	Name
1	Brown	N/C
2	—	—
3	Blue	LASER
4	Black	GND

Appendix A: Troubleshooting the MCDC-01

The MCDC-01 has a FAULT LED to help troubleshoot WeldROVER problems. The FAULT LED illuminates when a limitation value has been reached and maintained for more than two seconds. Table 1 on page 99 lists the faults, limitation values, and recommended actions.

Table 1 MCDC-01 FAULT LED and recommended actions

Fault	Threshold	Action ^a
One of the current limitation values has been exceeded.	6 A continuous 10 A peak	Ensure that the WeldROVER's movement is not restrained in any way.
The permissible speed deviation has been exceeded.	0.8 mm/s gap between the remote-control set speed and the real speed of the motorized scanner.	Check for: <ul style="list-style-type: none"> - Too much weight on the scanner; - Debris or obstruction on the inspection path; - Not enough clearance for the scanner (use the low-profile configuration if necessary [see "Configurations" on page 43]); - Wedges are not in proper contact with the surface; - Umbilical is caught as a result of its movement; etc.
The maximum drive temperature has been exceeded.	85 °C (185 °F)	Let the unit cool down.

Table 1 MCDC-01 FAULT LED and recommended actions (continued)

Fault	Threshold	Action*
An overvoltage is detected	32 V	This normally should not occur, because the power supply provided with the WeldROVER system is 24 VDC (see Table 3 on page 74). If this does occur, verify the output voltage of your power supply (see Table 8 on page 81).

a. See the following notes.

NOTE

If you experience a problem with the system but the MCDC-01 fault LED has not illuminated, verify that all cable connectors are tightly connected.

IMPORTANT

After a problem has been encountered and resolved, you might have to reset the MCDC-01. To reset the MCDC-01:

- ◆ Turn off and then turn on the MCDC-01 using the power switch.
-

IMPORTANT

If the proposed solutions do not work, contact your nearest Evident service center. The list of Evident service centers is available at:

<https://www.olympus-ims.com/en/service-and-support/service-centers/>.

Appendix B: Maintenance

The wedges and probes used on the WeldROVER might eventually require replacement or adjustment, depending on operating conditions and user requirements. WeldROVER system components may also require periodic cleaning.

B.1 Adjustment of the Carbide Wear-Pins on Wedges

Wedges are designed to hold a transducer or a phased array probe in order to ensure an adequate ultrasonic diffusion through the surface being inspected, and to direct the couplant flow correctly. To limit wear of the wedge, carbide wear pins can be inserted at each corner of the contact surface of the wedge (see Figure B-1 on page 102).

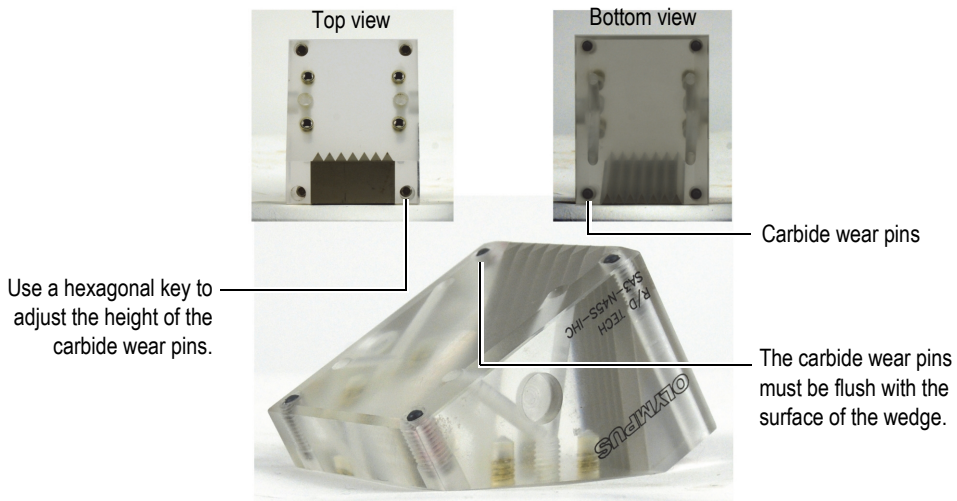

Figure B-1 Wedges—Adjusting the carbide wear pins

To adjust the carbide wear pins on a wedge

1. Turn off the couplant flow.
2. Use a hexagonal key to adjust the height of the carbide wear pins on each installed wedge. Ensure that the top of each pin is flush with the surface of the wedge (see Figure B-1 on page 102).

B.2 Replacing a Conventional Ultrasonic Transducer

To replace a conventional ultrasonic transducer, the assembly holding the transducer must be removed and partially disassembled.

To replace a conventional ultrasonic transducer

1. Turn off the couplant flow.
2. Disconnect the couplant tubes from the couplant source, or from the wedge.
3. Remove the scanner from the inspection surface (see “To remove the WeldROVER from a ferromagnetic surface” on page 58).
4. Disconnect the transducer cable.

5. Use the hexagonal key to free the yoke arm holding the wedge.
6. Ensure that the transducer cable is disconnected, and then unscrew the transducer from the wedge.
It is possible to unscrew the transducer without removing the wedge.
7. Screw the new transducer onto the wedge.

NOTE

Before installing a new transducer on the wedge, ensure that there is a sufficient amount of couplant between the transducer and the wedge.

8. Tighten the transducer on the wedge.

**CAUTION**

Do not overtighten the transducer; overtightening might crack the wedge.

9. Reinstall the wedge-probe assembly onto the yoke.

B.3 Replacing a Phased Array Probe

To replace a phased array ultrasonic probe, the probe assembly must be removed and partially disassembled.

To replace a phased array probe

1. Turn off the couplant flow.
2. Disconnect the couplant tubes from the couplant source.
3. Disconnect the probe cable from the instrument.

**CAUTION**

To prevent any damage to the Hypertronics connector pins, be sure to always install the protective cover when the probe cable is disconnected.

4. Remove the scanner from the inspection surface (see “To remove the WeldROVER from a ferromagnetic surface” on page 58).
 5. Use the hexagonal key to free the yoke arm holding the wedge.
 6. Using a cross-headed screwdriver, unscrew the screws that hold the probe on the wedge (either two or four screws, depending on the model), and then remove the probe.
 7. Install the new probe onto the wedge.
-

NOTE

Before installing a new probe on the wedge, ensure that there is a sufficient amount of couplant between the probe and the wedge.

8. Tighten the screws that hold the probe on the wedge.
-



CAUTION

Do not overtighten the screws; overtightening might crack the wedge.

9. Reinstall the wedge-probe assembly onto the yoke.

B.4 Unit Cleaning

The WeldROVER’s external surfaces can be cleaned when needed.



WARNING



The WeldROVER generates a magnetic field strong enough to affect pace makers, watches, and other sensitive electronic devices, and anyone wearing or depending on such devices should keep a safe distance away from the WeldROVER to avoid the risk of serious injuries or death. This magnetic field can also demagnetize credit cards, magnetic ID (identification) badges, etc. The wheels’ magnetic force is strong and may

be attracted to a ferromagnetic material without warning. Sharp filings can be attracted and attached to the wheels. See also “Magnetic Wheels and Related Safety Information” on page 29.

IMPORTANT

The magnetic wheels must be inspected before each inspection and cleaned, if necessary. For details, see “Cleaning the Magnetic Wheels” on page 63.

To clean the unit

1. Ensure the unit is turned off by removing the source of power.
2. Disconnect all cables.
3. To bring the unit back to its original finish, clean the housing with a soft cloth.
4. To remove persistent stains, use a damp cloth with a soft, soapy solution. Do not use abrasive products or powerful solvents that could damage the finish.
5. Wait until the unit dries completely before reconnecting the cables.

List of Figures

Figure 1-1	WeldROVER system	25
Figure 1-2	WeldROVER – remote control	26
Figure 1-3	MCDC-01 – motion control unit (LED panel)	27
Figure 1-4	MCDC-01 – motion control unit (switch panel)	28
Figure 1-5	WeldROVER scanner – main components	29
Figure 1-6	WeldROVER scanner – magnetic wheel	30
Figure 1-7	WeldROVER – Three types of probe holder	32
Figure 2-1	WeldROVER – emergency-stop button	34
Figure 2-2	WeldROVER – butterfly latches	35
Figure 2-3	WeldROVER – distribution of the main elements under the cover	36
Figure 2-4	WeldROVER – umbilical fastening mechanism and connectors	37
Figure 2-5	Umbilical – draw-in-tool and divisible conduit	38
Figure 2-6	Umbilical – the overall shell over the divisible conduit	39
Figure 2-7	WeldROVER – laser guide position adjustment	40
Figure 2-8	WeldROVER – Installing the frame bar	41
Figure 2-9	WeldROVER – Two steering levers are provided with the system	42
Figure 2-10	WeldROVER – removing the handle	42
Figure 2-11	WeldROVER – example of a three-pair probe configuration	45
Figure 2-12	WeldROVER – installing the offset bracket	45
Figure 2-13	WeldROVER – an example of a back and front configuration	46
Figure 2-14	WeldROVER – clearance with low-profile configuration – flat surface	47
Figure 2-15	WeldROVER – radial clearance – low-profile configuration	48
Figure 2-16	WeldROVER – two probes at the front and two probes at the back	48
Figure 2-17	WeldROVER – four probes at the front	49
Figure 2-18	WeldROVER – six probes at the front	49
Figure 2-19	WeldROVER – Yoke arm length measurement	50
Figure 2-20	WeldROVER – PCS measurement for PA wedges	51
Figure 2-21	WeldROVER – PCS measurement for TOFD wedges	51
Figure 2-22	WeldROVER – PCS for SA12 wedge type	53
Figure 2-23	WeldROVER – PCS for SPWZ or SA14 wedge types	54

Figure 2-24	WeldROVER – PCS for TOFD wedge type	55
Figure 2-25	WeldROVER – yoke orientation	56
Figure 3-1	WeldROVER – Rotating probe-holder arm	60
Figure 3-2	WeldROVER – two height positions for the SLA	61
Figure 3-3	WeldROVER – Approximate 90° angle between the SLA and the yoke ...	62
Figure 3-4	WeldROVER – Stainless steel brush on the wheel	64
Figure 4-1	WeldROVER – Remote control for MCDC-01	66
Figure 5-1	WeldROVER – standard hard carrying case	71
Figure 5-2	WeldROVER – optional hard carrying case	72
Figure 5-3	WeldROVER hard carrying case – mobile workstation configuration	72
Figure 5-4	WeldROVER – transporting the system in the field	73
Figure 5-5	WeldROVER system – Principal components	73
Figure 5-6	Yoke geometry	75
Figure 5-7	WeldROVER scanner exploded view	77
Figure 6-1	WeldROVER scanner – weld cap clearance	82
Figure 7-1	MCDC-01 – connector identification	84
Figure 7-2	MCDC-01 – Power-In connector	85
Figure 7-3	MCDC-01 – Suggested mating connector for power supply	85
Figure 7-4	MCDC-01 – Encoder Out connector	86
Figure 7-5	MCDC-01 – Encoder Out mating cord set	87
Figure 7-6	OmniScan MX2 or SX – Encoder Out mating cord set	88
Figure 7-7	MCDC-01 – Remote control connector	89
Figure 7-8	MCDC-01 – Remote control mating connector	90
Figure 7-9	MCDC-01 – Scanner connector	91
Figure 7-10	MCDC-01 – Scanner mating cord set	92
Figure 7-11	MCDC-01 – RS-232 communication port	93
Figure 7-12	MCDC-01 – RS-232 communication port mating cord set	94
Figure 7-13	WeldROVER scanner – Connectors location	95
Figure 7-14	WeldROVER scanner – Control connector	96
Figure 7-15	WeldROVER scanner – Control mating cable	96
Figure 7-16	WeldROVER scanner – Laser guide connector	98
Figure 7-17	WeldROVER scanner – Laser guide mating connector	98
Figure B-1	Wedges – Adjusting the carbide wear pins	102

List of Tables

Table 1	WeldROVER—number of probes according to diameter	44
Table 2	WeldROVER—Probe-center separation (PCS) for typical wedges	51
Table 3	WeldROVER part numbers for principal components	74
Table 4	Replacement yokes	75
Table 5	Couplant-feed units	76
Table 6	Required encoder cable adaptor	76
Table 7	WeldROVER scanner spare parts list	78
Table 8	WeldROVER specifications	81
Table 9	WeldROVER—Power supply specifications	82
Table 10	WeldROVER scanner—physical characteristics	82
Table 11	MCDC-01—Pinout for the power supply’s mating cord set	85
Table 12	MCDC-01—Pinout for the Encoder Out mating cord set	87
Table 13	OmniScan MX2 or SX—Pinout for Encoder Out mating cord set	88
Table 14	MCDC-01—Pinout for remote controller’s mating cord set	90
Table 15	MCDC-01—Pinout for scanner connector’s mating cord set	92
Table 16	MCDC-01—Pinout for RS-232 communication port’s mating cord set	94
Table 17	Scanner—Pinout for control connector’s mating cord set	97
Table 18	Scanner—Pinout for laser guide’s mating cord set connector	98
Table 19	MCDC-01 FAULT LED and recommended actions	99

