



ChainSCANNER

Chain-Link Mounted Scanner

User's Manual

DMTA069-01EN — Rev. E
September 2022

This instruction manual contains essential information on how to use this Evident product safely and effectively. Before using this product, thoroughly review this instruction manual. Use the product as instructed. Keep this instruction manual in a safe, accessible location.

EVIDENT CANADA, 3415, Rue Pierre-Ardouin, Québec (QC) G1P 0B3 Canada

Copyright © 2022 by Evident. All rights reserved. No part of this publication may be reproduced, translated, or distributed without the express written permission of Evident.

This document was prepared with particular attention to usage to ensure the accuracy of the information contained therein, and corresponds to the version of the product manufactured prior to the date appearing on the title page. There could, however, be some differences between the manual and the product if the product was modified thereafter.

The information contained in this document is subject to change without notice.

Part number: DMTA069-01EN

Rev. E

September 2022

Printed in Canada

All brands are trademarks or registered trademarks of their respective owners and third party entities.

Table of Contents

List of Abbreviations	7
Important Information – Please Read Before Use	9
Intended Use	9
Instruction Manual	9
Device Compatibility	10
Repair and Modification	10
Safety Symbols	10
Safety Signal Words	11
Note Signal Words	12
Safety	12
Warnings	12
Battery Precautions	13
Regulations for Shipping Products with Lithium-Ion Batteries	15
Equipment Disposal	15
BC (Battery Charger - California, USA Community)	15
CE (European Community)	16
UKCA (United Kingdom)	16
RCM (Australia)	16
WEEE Directive	16
China RoHS	17
Korea Communications Commission (KCC)	18
EMC Directive Compliance	18
FCC (USA) Compliance	19
ICES-001 (Canada) Compliance	20
Warranty Information	20
Technical Support	21

Introduction	23
1. Overview	25
1.1 Slide Bar Assembly	26
1.2 Probe Displacement System	26
1.3 Probe-Holder Assembly	27
1.4 Buckle Assembly	28
1.5 Main Module and Encoder Umbilical Cable	29
1.6 Y-Axis Encoder	30
1.7 Short and Long Links	31
2. ChainSCANNER Setup and Connection	33
2.1 Main Module Setup and Connection	33
2.2 ChainSCANNER Setup	38
2.3 Probe Holders Adjustment and Maintenance	39
2.4 Changing the Yoke Arm to Fit the Length of a Wedge	44
2.5 Slide Bar, Lead Screw, and Y-Axis Adjustment	46
2.6 Y-Axis Encoder Removal and Installation	47
2.7 Umbilical Sheath Strain Relief Assembly	48
2.8 Optional Four-Probe Kit	52
2.9 Optional Mouse Conversion Kit	54
2.10 Optional 20-Centimeter Bar and Lead Screw Kit	58
3. Preparing the ChainSCANNER for an Inspection	61
4. Operating the ChainSCANNER	65
5. Maintenance	67
5.1 Preventive Maintenance	67
5.2 Unit Cleaning	67
6. Spare Parts and Optional Kits	69
6.1 Spare Parts	69
6.2 Optional Kits and Parts	74
7. ChainSCANNER Specifications	79
7.1 General and Operating Environment Specifications	79
7.2 Connector Reference	80

Appendix A: ChainSCANNER Sizing Charts 83

Appendix B: Wedge-Probe Assembly Maintenance 89

 B.1 Adjustment of the Carbide Wear-Pins on Wedges 89

 B.2 Replacing a Conventional Ultrasonic Transducer 90

 B.3 Replacing a Phased Array Probe 92

List of Figures 95

List of Tables 97

List of Abbreviations

EFUP	environment-friendly use period
N/A	not applicable
OD	outside diameter
P/N	part number
TOFD	time-of-flight diffraction

Important Information — Please Read Before Use

Intended Use

The ChainSCANNER is designed to perform nondestructive inspections on industrial and commercial materials.



WARNING

Do not use the ChainSCANNER for any purpose other than its intended use. It must never be used to inspect or examine human or animal body parts.

Instruction Manual

This instruction manual contains essential information on how to use this product safely and effectively. Before using this product, thoroughly review this instruction manual. Use the product as instructed. Keep this instruction manual in a safe, accessible location.

IMPORTANT

Some of the details of components illustrated in this manual may differ from the components installed on your device. However, the operating principles remain the same.

Device Compatibility

Only use this device with the approved ancillary equipment provided by Evident. Equipment provided by Evident and approved for use with this device is described later in this manual.



CAUTION

Always use equipment and accessories that meet Evident specifications. Using incompatible equipment could cause equipment malfunction and/or damage, or human injury.

Repair and Modification

This device does not contain any user-serviceable parts. Opening the device might void the warranty.



CAUTION

In order to prevent human injury and/or equipment damage, do not disassemble, modify, or attempt to repair the device.

Safety Symbols

The following safety symbols might appear on the device and in the instruction manual:



General warning symbol

This symbol is used to alert the user to potential hazards. All safety messages that follow this symbol shall be obeyed to avoid possible harm or material damage.



High voltage warning symbol

This symbol is used to alert the user to potential electric shock hazards greater than 1000 volts. All safety messages that follow this symbol shall be obeyed to avoid possible harm.

Safety Signal Words

The following safety symbols might appear in the documentation of the device:



DANGER

The DANGER signal word indicates an imminently hazardous situation. It calls attention to a procedure, practice, or the like, which, if not correctly performed or adhered to, will result in death or serious personal injury. Do not proceed beyond a DANGER signal word until the indicated conditions are fully understood and met.



WARNING

The WARNING signal word indicates a potentially hazardous situation. It calls attention to a procedure, practice, or the like, which, if not correctly performed or adhered to, could result in death or serious personal injury. Do not proceed beyond a WARNING signal word until the indicated conditions are fully understood and met.



CAUTION

The CAUTION signal word indicates a potentially hazardous situation. It calls attention to an operating procedure, practice, or the like, which, if not correctly performed or adhered to, may result in minor or moderate personal injury, material damage, particularly to the product, destruction of part or all of the product, or loss of data. Do not proceed beyond a CAUTION signal word until the indicated conditions are fully understood and met.

Note Signal Words

The following note signal words could appear in the documentation of the device:

IMPORTANT

The IMPORTANT signal word calls attention to a note that provides important information, or information essential to the completion of a task.

NOTE

The NOTE signal word calls attention to an operating procedure, practice, or the like, which requires special attention. A note also denotes related parenthetical information that is useful, but not imperative.

TIP

The TIP signal word calls attention to a type of note that helps you apply the techniques and procedures described in the manual to your specific needs, or provides hints on how to effectively use the capabilities of the product.

Safety

Before turning on the device, verify that the correct safety precautions have been taken (see the following warnings). In addition, note the external markings on the device, which are described under “Safety Symbols.”

Warnings



WARNING

General Warnings

- Carefully read the instructions contained in this instruction manual prior to turning on the device.
- Keep this instruction manual in a safe place for further reference.

- Follow the installation and operation procedures.
- It is imperative to respect the safety warnings on the device and in this instruction manual.
- If the equipment is used in a manner not specified by the manufacturer, the protection provided by the equipment could be impaired.
- Do not install substitute parts or perform any unauthorized modification to the device.
- Service instructions, when applicable, are for trained service personnel. To avoid the risk of electric shock, do not perform any work on the device unless qualified to do so. For any problem or question regarding this device, contact Evident or an authorized Evident representative.
- Do not touch the connectors directly by hand. Otherwise, a malfunction or electric shock may result.
- Do not allow metallic or foreign objects to enter the device through connectors or any other openings. Otherwise, a malfunction or electric shock may result.

**WARNING****Electrical Warning**

The device must only be connected to a power source corresponding to the type indicated on the rating label.

**CAUTION**

If a non-approved power supply cord not dedicated to Evident products is used, Evident will not be able to ensure the electrical safety of the equipment.

Battery Precautions**CAUTION**

- Before disposing of a battery, check your local laws, rules, and regulations, and follow them accordingly.

- Transportation of lithium-ion batteries is regulated by the United Nations under the United Nations Recommendations on the Transport of Dangerous Goods. It is expected that governments, intergovernmental organizations, and other international organizations shall conform to the principles laid down in these regulations, thus contributing to worldwide harmonization in this field. These international organizations include the International Civil Aviation organization (ICAO), the International Air Transport Association (IATA), the International Maritime Organization (IMO), the US Department of Transportation (USDOT), Transport Canada (TC), and others. Please contact the transporter and confirm current regulations before transportation of lithium-ion batteries.
- For California (USA) only:
The device may contain a CR battery. The CR battery contains perchlorate material, and special handling may be required. Refer to <http://www.dtsc.ca.gov/hazardouswaste/perchlorate>.
- Do not open, crush, or perforate batteries; doing so could cause injury.
- Do not incinerate batteries. Keep batteries away from fire and other sources of extreme heat. Exposing batteries to extreme heat (over 80 °C) could result in an explosion or personal injury.
- Do not drop, hit, or otherwise abuse a battery, as doing so could expose the cell contents, which are corrosive and explosive.
- Do not short-circuit the battery terminals. A short circuit could cause injury and severe damage to a battery making it unusable.
- Do not expose a battery to moisture or rain; doing so could cause an electric shock.
- Only use an external charger approved by Evident to charge the batteries.
- Only use batteries supplied by Evident.
- Do not store batteries that have less than 40 % remaining charge. Recharge batteries to between 40 % and 80 % capacity before storing them.
- During storage, keep the battery charge between 40 % and 80 %.
- Do not leave batteries in the ChainSCANNER unit during device storage.

Regulations for Shipping Products with Lithium-Ion Batteries

IMPORTANT

When shipping a Li-ion battery or batteries, be sure to follow all local transportation regulations.



WARNING

Damaged batteries cannot be shipped through normal routes — DO NOT ship damaged batteries to Evident. Contact your local Evident representative or material disposal professionals.

Equipment Disposal

Before disposing of the ChainSCANNER, check your local laws, rules, and regulations, and follow them accordingly.

BC (Battery Charger - California, USA Community)



The BC marking indicates that this product has been tested and complies with the Appliance Efficiency Regulations as stated in the California Code of Regulations Title 20, Sections 1601 through 1608 for Battery Charger Systems. The internal battery charger within this device has been tested and certified pursuant to the California Energy Commission's (CEC) requirements; this device is listed on the online CEC's (T20) database.

CE (European Community)



This device complies with the requirements of directive 2014/30/EU concerning electromagnetic compatibility, directive 2014/35/EU concerning low voltage, and directive 2015/863 which amends 2011/65/EU concerning restriction of hazardous substances (RoHS). The CE marking is a declaration that this product conforms to all the applicable directives of the European Community.

UKCA (United Kingdom)



This device complies with the requirements of the Electromagnetic Compatibility Regulations 2016, the Electrical Equipment (Safety) Regulations 2016, and the Restriction of the Use of Certain Hazardous Substances in Electrical and Electronic Equipment Regulations 2012. The UKCA marking indicates compliance with the above regulations.

RCM (Australia)



The regulatory compliance mark (RCM) label indicates that the product complies with all applicable standards, and has been registered with the Australian Communications and Media Authority (ACMA) for placement on the Australian market.

WEEE Directive



In accordance with European Directive 2012/19/EU on Waste Electrical and Electronic Equipment (WEEE), this symbol indicates that the product must not be disposed of as unsorted municipal waste, but should be collected separately. Refer to your local Evident distributor for return and/or collection systems available in your country.



China RoHS

China RoHS is the term used by industry generally to describe legislation implemented by the Ministry of Information Industry (MII) in the People's Republic of China for the control of pollution by electronic information products (EIP).



The China RoHS mark indicates the product's Environment-Friendly Use Period (EFUP). The EFUP is defined as the number of years for which listed controlled substances will not leak or chemically deteriorate while in the product. The EFUP for the ChainSCANNER has been determined to be 15 years.

Note: The Environment-Friendly Use Period (EFUP) is not meant to be interpreted as the period assuring functionality and product performance.



电器电子产品有害
物质限制使用
标志

本标志是根据“电器电子产品有害物质限制使用管理办法”以及“电子电气产品有害物质限制使用标识要求”的规定，适用于在中国销售的电器电子产品上的电器电子产品有害物质使用限制标志。

（注意）电器电子产品有害物质限制使用标志内的数字为在正常的使用条件下有害物质等不泄漏的期限，不是保证产品功能性能的期间。

产品中有害物质的名称及含量

部件名称		有害物质					
		铅及其化合物 (Pb)	汞及其化合物 (Hg)	镉及其化合物 (Cd)	六价铬及其化合物 (Cr(VI))	多溴联苯 (PBB)	多溴二苯醚 (PBDE)
主体	机构部件	×	○	○	○	○	○
	光学部件	×	○	○	○	○	○
	电气部件	×	○	○	○	○	○

产品中有害物质的名称及含量

部件名称	有害物质					
	铅及其化合物 (Pb)	汞及其化合物 (Hg)	镉及其化合物 (Cd)	六价铬及其化合物 (Cr(VI))	多溴联苯 (PBB)	多溴二苯醚 (PBDE)
附件	×	○	○	○	○	○
本表格依据 SJ/T 11364 的规定编制。 ○：表示该有害物质在该部件所有均质材料中的含量均在 GB/T26572 规定的限量要求以下。 ×：表示该有害物质至少在该部件的某一均质材料中的含量超出 GB/T26572 规定的限量要求。						

Korea Communications Commission (KCC)



Seller and user shall be noticed that this equipment is suitable for electromagnetic equipment for office work (class A) and it can be used outside the home. This device complies with the EMC requirements of Korea.

이 기기는 업무용 환경에서 사용할 목적으로 적합성평가를 받은 기기로서 가정용 환경에서 사용하는 경우 전파간섭의 우려가 있습니다 .

EMC Directive Compliance

This equipment generates and uses radio-frequency energy and, if not installed and used properly (that is, in strict accordance with the manufacturer's instructions), may cause interference. The ChainSCANNER has been tested and found to comply with the limits for an industrial device in accordance with the specifications of the EMC directive.

FCC (USA) Compliance

NOTE

This product has been tested and found to comply with the limits for a Class A digital device, pursuant to Part 15 of the FCC Rules. These limits are designed to provide reasonable protection against harmful interference when the product is operated in a commercial environment. This product generates, uses, and can radiate radio frequency energy, and if not installed and used in accordance with the instruction manual, might cause harmful interference to radio communications. Operation of this product in a residential area is likely to cause harmful interference, in which case you will be required to correct the interference at your own expense.

IMPORTANT

Changes or modifications not expressly approved by the party responsible for compliance could void the user's authority to operate the product.

FCC Supplier's Declaration of Conformity

Hereby declares that the product,

Product name: ChainSCANNER

Model: ChainSCANNER-MR/ChainSCANNER-CW

Conforms to the following specifications:

FCC Part 15, Subpart B, Section 15.107 and Section 15.109.

Supplementary information:

This device complies with Part 15 of the FCC Rules. Operation is subject to the following two conditions:

- (1) This device may not cause harmful interference.
- (2) This device must accept any interference received, including interference that may cause undesired operation.

Responsible party name:

EVIDENT CANADA

Address:

3415, Rue Pierre-Ardouin Québec (QC) G1P 0B3 Canada

Phone number:

+1 781-419-3900

ICES-001 (Canada) Compliance

This Class A digital apparatus complies with Canadian ICES-001.

Cet appareil numérique de la classe A est conforme à la norme NMB-001 du Canada.

Warranty Information

Evident guarantees your Evident product to be free from defects in materials and workmanship for a specific period, and in accordance with conditions specified in the Terms and Conditions available at <https://www.olympus-ims.com/en/terms/>.

The Evident warranty only covers equipment that has been used in a proper manner, as described in this instruction manual, and that has not been subjected to excessive abuse, attempted unauthorized repair, or modification.

Inspect materials thoroughly on receipt for evidence of external or internal damage that might have occurred during shipment. Immediately notify the carrier making the delivery of any damage, because the carrier is normally liable for damage during shipment. Retain packing materials, waybills, and other shipping documentation needed in order to file a damage claim. After notifying the carrier, contact Evident for assistance with the damage claim and equipment replacement, if necessary.

This instruction manual explains the proper operation of your Evident product. The information contained herein is intended solely as a teaching aid, and shall not be used in any particular application without independent testing and/or verification by the operator or the supervisor. Such independent verification of procedures becomes increasingly important as the criticality of the application increases. For this reason, Evident makes no warranty, expressed or implied, that the techniques, examples, or procedures described herein are consistent with industry standards, nor that they meet the requirements of any particular application.

Evident reserves the right to modify any product without incurring the responsibility for modifying previously manufactured products.

Technical Support

Evident is firmly committed to providing the highest level of customer service and product support. If you experience any difficulties when using our product, or if it fails to operate as described in the documentation, first consult the user's manual, and then, if you are still in need of assistance, contact our After-Sales Service. To locate the nearest service center, visit the Service Centers page on the Evident Scientific Web site.

Introduction

This manual provides instructions for assembling, installing, and operating the ChainSCANNER. The ChainSCANNER is a manual pipe inspection scanner for outside pipe diameters ranging from 45 mm to 965 mm (1.75 in. to 38 in.). The ChainSCANNER allows encoding the position on the two axes.

This manual is organized to allow a progressive understanding of the scanner's different functions. Each section, however, is complete in itself. This manual is therefore a useful reference.

1. Overview

This chapter provides an overview of the ChainSCANNER components in the standard configuration. The scanner is shown in Figure 1-1 on page 25. A description of each component follows.

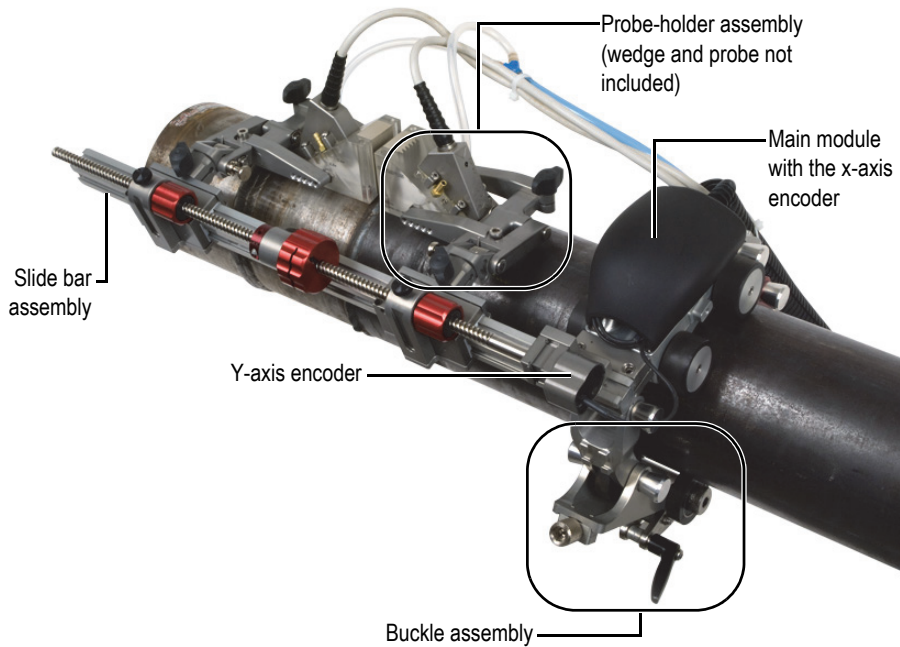

Figure 1-1 The ChainSCANNER main components

1.1 Slide Bar Assembly

The slide bar holds most of the components of the ChainSCANNER, and permits easy and precise positioning of the probe-holder assemblies (see Figure 1-2 on page 26).

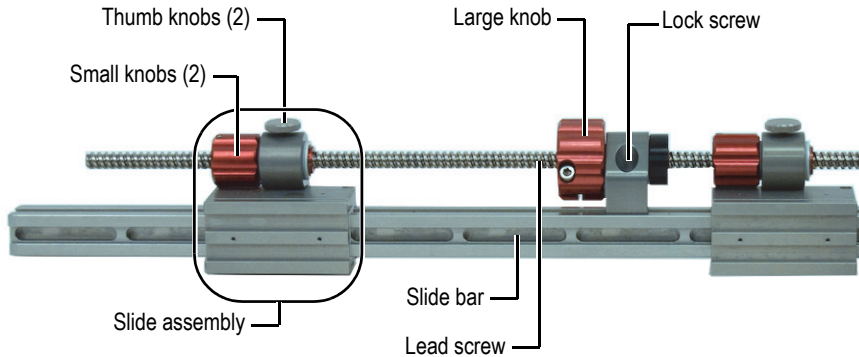

Figure 1-2 The slide bar assembly

The slide bar assembly can hold a pair of probe holders. These can be either conventional ultrasonic transducers or phased array probes.

1.2 Probe Displacement System

The probe displacement system offers a convenient way to adjust the distance between the probes and to center the pair of probes over the surface to be inspected by using a convenient lead screw system. However, it is not required, and the probe holders can be attached directly to the dovetail groove of the slide bar (see Figure 1-3 on page 27).

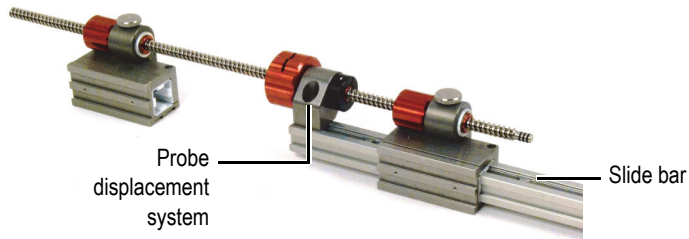

Figure 1-3 The probe displacement system

1.3 Probe-Holder Assembly

The probe-holder assembly is designed to hold a wedge-probe assembly and to ensure contact between the wedge and the surface (see Figure 1-4 on page 28).

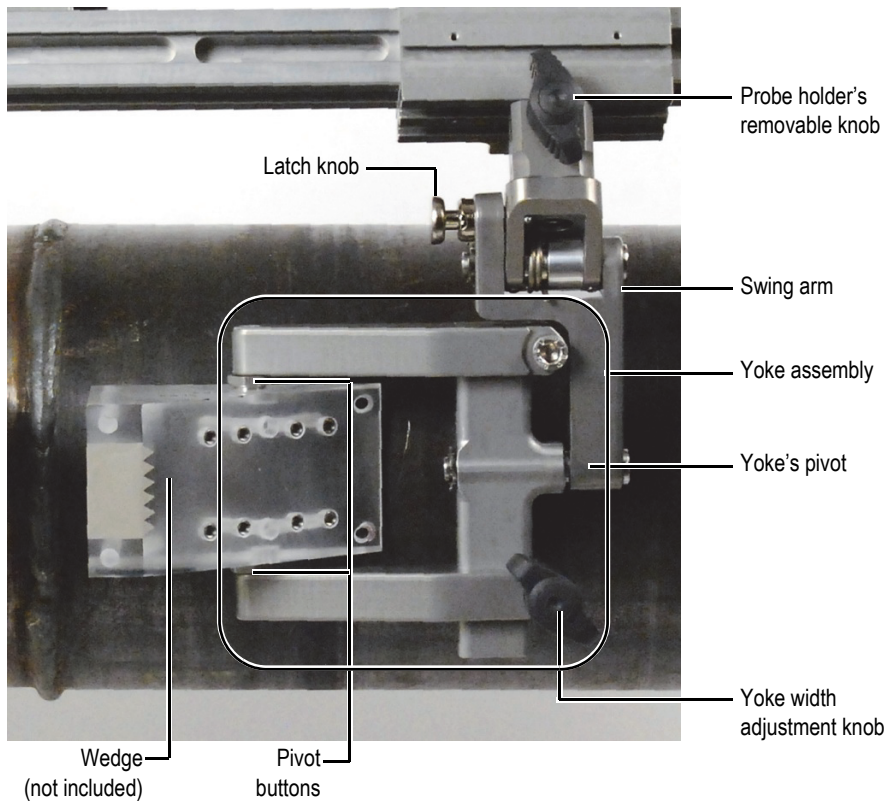

Figure 1-4 The probe-holder assembly parts

The pair of pivot buttons must be changed to match the size of the wedge pivot holes. Phased array wedges require 8 mm (0.312 in.) pivot buttons. Pulse-echo and TOFD wedges require 5 mm (0.204 in.) pivot buttons.

The length of the yoke arms can also be changed to suit the length of the wedge (see "To change the yoke arms" on page 45).

1.4 Buckle Assembly

The purpose of the buckle assembly is to attach the ChainSCANNER and to adjust the tension around the pipe (see Figure 1-5 on page 29). For extra-small

pipe outside diameters (OD), the catch link can be removed and the buckle arm hooked directly onto the rear attachment of the main module (see Figure 3-1 on page 62).

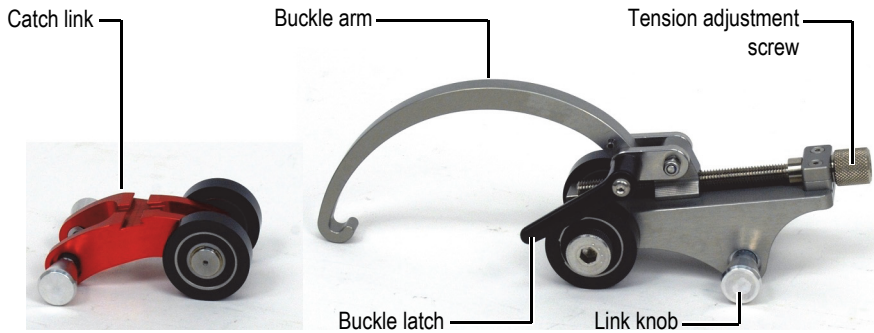

Figure 1-5 The buckle assembly parts

1.5 Main Module and Encoder Umbilical Cable

The main module of the ChainSCANNER offers an ergonomic grip to manipulate the scanner (see Figure 1-7 on page 30). The main module also holds an internal x-axis encoder and its connector. The umbilical encoder cable connects to the x-axis connector and provides the y-axis encoder connector (see Figure 1-6 on page 29).

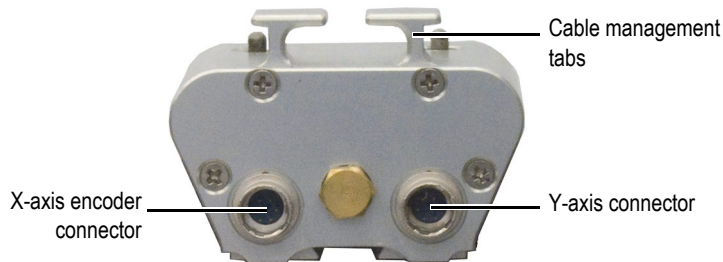

Figure 1-6 The encoder umbilical cable

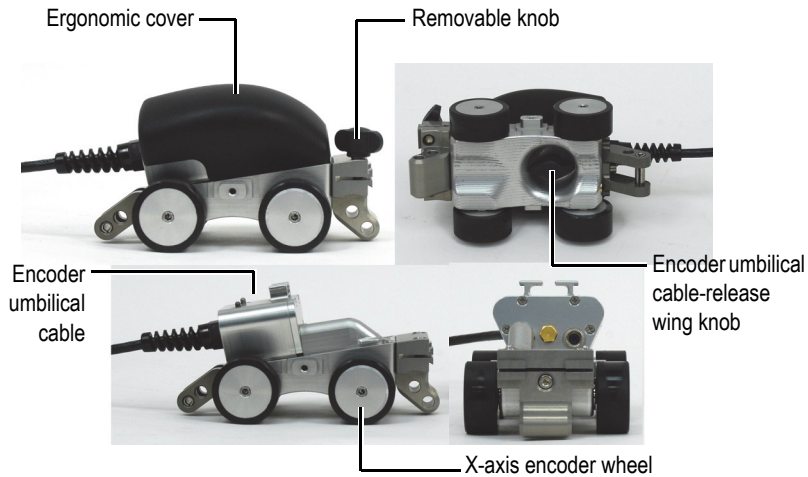

Figure 1-7 The main module components

1.6 Y-Axis Encoder

The y-axis encoder measures the probe holders displacement on the lateral axis (see Figure 1-8 on page 30).

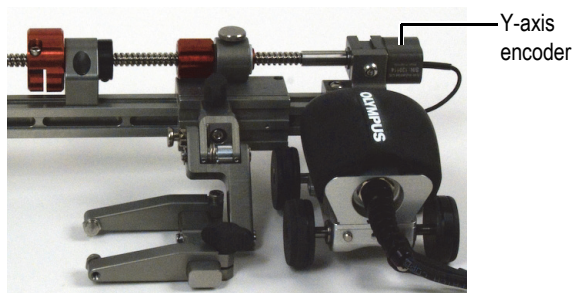

Figure 1-8 The y-axis encoder location

The y-axis encoder is waterproof, like the x-axis encoder.

1.7 Short and Long Links

Links can be added or removed to alter the chain length. This is accomplished by simply pulling out on the link knobs to retract the pins, which hold the links together. To facilitate the reassembly, the knobs can be latched open by pulling them out and rotating them slightly (see Figure 1-9 on page 31).

There are two link lengths for the ChainSCANNER — short links (P/N: CHAINSCAN-A-SLINK [U8775127]) and long links (P/N: CHAINSCAN-A-LGLINK [U8750042]). Consult Table 8 on page 84 or Table 9 on page 86 to find the adequate combination of links according to the outside diameter of the surface to be inspected.

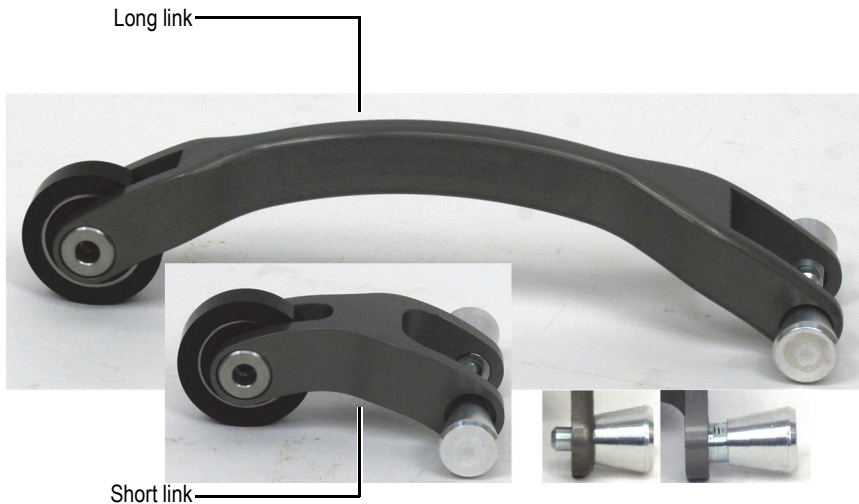

Figure 1-9 The short and long links

NOTE

The ChainSCANNER is not recommended for pipes larger than 965 mm (38 in.) OD, because on pipes above this diameter, the scanner tends to make ellipsoidal rotations, which makes it difficult to align the probes with the weld.

2. ChainSCANNER Setup and Connection

The ChainSCANNER is designed so that part changes and adjustments can be easily carried out. This chapter provides procedures for the main module, chain links, probe holders, y-axis, umbilical cable, and optional parts kits.

2.1 Main Module Setup and Connection

This section gives the procedures used to configure the main module in order to use it as a component of the ChainSCANNER. To use the main module in the mouse scanner configuration, the optional mouse conversion kit is required, see “Optional Mouse Conversion Kit” on page 54.

To couple the main module and the slide bar

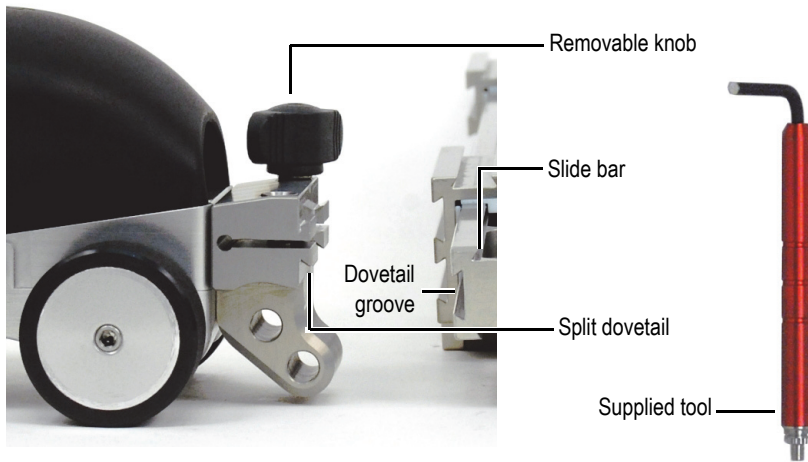

Figure 2-1 Coupling the main module with the slide bar

1. If there is enough room to manipulate the removable knob, use it to couple the main module to the slide bar. When there is not enough room, remove the knob (simply pull it out), and use the supplied tool (insert into the screws) (see Figure 2-1 on page 34).
2. Turn the removable knob, or the tool, clockwise to collapse the split dovetail. Do the same with the other screw.
3. Insert the collapsed split dovetail into the dovetail groove.
4. Turn the removable knob, or the tool, counterclockwise to secure the split dovetail into the dovetail groove.
5. Ensure that the two screws are secured.

TIP

Using the split dovetail assembling mode is somewhat counterintuitive, since you have to turn *clockwise* to loosen the mounting (in fact, collapsing the split dovetail), and *counterclockwise* to secure the mount (in fact, opening the split dovetail).

Once the split dovetail is collapsed, it can be inserted anywhere along the dovetail groove (see Figure 2-2 on page 35).

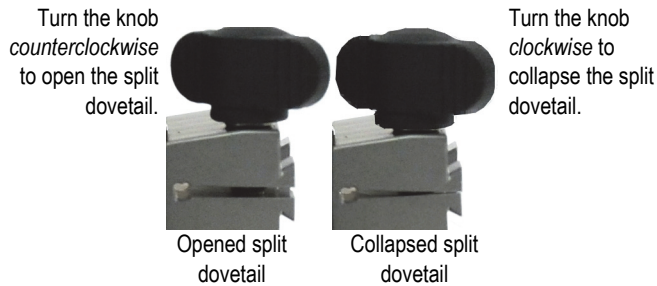

Figure 2-2 Collapsing and opening a split dovetail

To remove the ergonomic cover

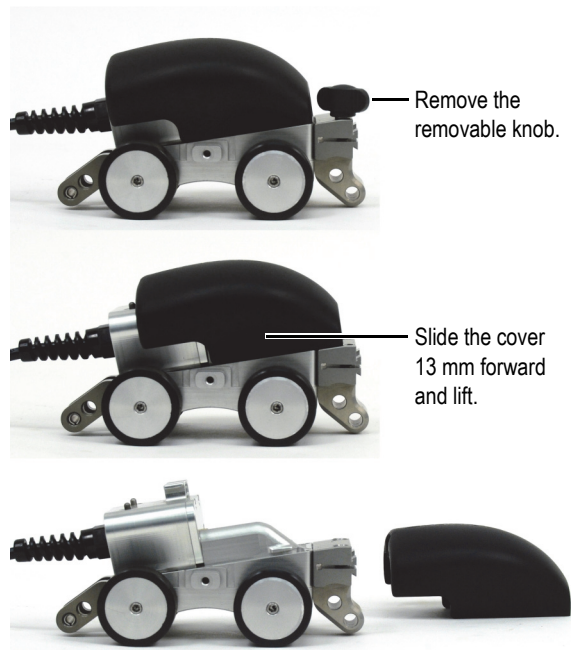

Figure 2-3 Removing the ergonomic cover

1. Pull out the removable knob if required (see Figure 2-3 on page 36).
2. Hold the metallic body of the main module.
3. Slide the cover forward approximately 13 mm (0.5 in.) and lift it straight up.
4. Reverse the operation to reinstall the ergonomic cover.

To install or release the encoder umbilical cable

1. Remove the ergonomic cover (see “To remove the ergonomic cover” on page 36).
2. Locate the encoder umbilical cable-release wing knob under the main module (see Figure 1-7 on page 30).
3. Loosen the wing knob by turning it counterclockwise.
4. Remove the encoder umbilical cable (see Figure 2-4 on page 37).

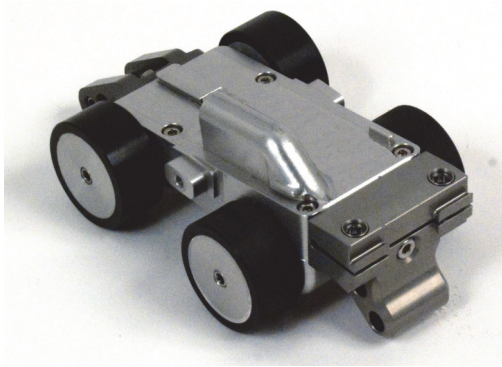

Figure 2-4 The main module without the encoder umbilical cable

5. Reverse the operation to install the encoder umbilical cable.

To connect the y-axis encoder cable

1. Remove the ergonomic cover (see “To remove the ergonomic cover” on page 36).

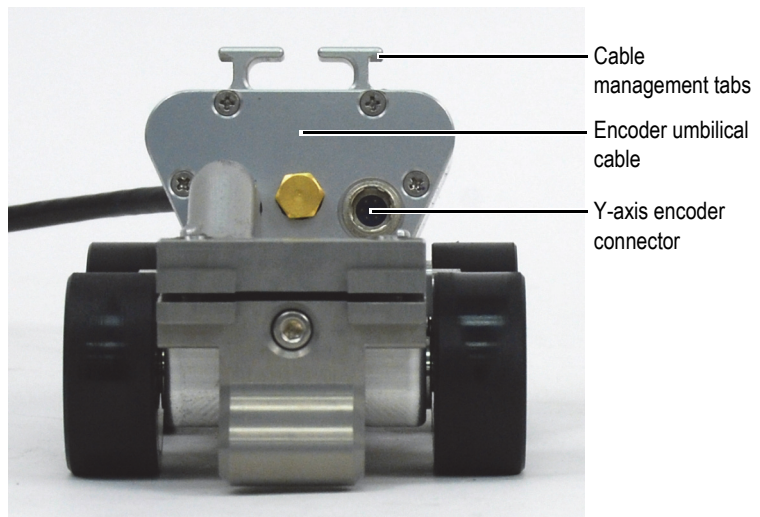

Figure 2-5 The encoder connector and the cable management tabs.

2. Connect the y-axis encoder cable to the encoder connector (see Figure 2-5 on page 37).
3. Use the cable management tabs and the ergonomic cover to conceal any excessive cable.



CAUTION

When reinstalling the ergonomic cover, take care to not pinch the encoder cables.

2.2 ChainSCANNER Setup

Refer to Table 8 on page 84 (inches) or Table 9 on page 86 (centimeters) to determine the correct combination of short and long links for a given pipe outside diameter, or for a given pipe circumference.

To add or remove a link on the ChainSCANNER

1. Measure the outside diameter or the circumference of the pipe to be inspected.
2. Use Table 8 on page 84 (inches) or Table 9 on page 86 (centimeters) to find the correct link combination.

IMPORTANT

On bigger pipes, long links are required at the front and the rear of the main module. Failure to do so will result in insufficient pressure between the wheel and the pipe, which will generate encoder count lost and reduce stability.

NOTE

Handles are supplied with the ChainSCANNER. Evident recommends installing them at intervals along the chain in order to help rotate the scanner around the pipe. A short link with dovetails is required to mount a handle.

3. Determine the position of the buckle assembly along the pipe circumference according to the following:

- When the catch link is used, the buckle-catch link assembly can be placed at any convenient location along the circumference of the pipe.
 - When the catch link is not used (on a pipe with a curvature smaller radius, for example), hook the buckle directly to the rear attachment of the main module.
4. Using the link knobs, assemble the selected links together (see Figure 2-6 on page 39).

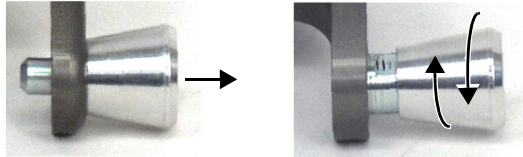

Figure 2-6 Pull out and rotate slightly to latch the link knobs to the open position.

5. Attach this link assembly to the front and rear attachments of the main module.

2.3 Probe Holders Adjustment and Maintenance

The ChainSCANNER can hold a pair of conventional UT probes or a pair of phased array probes. The probes are mounted on probe holders (see Figure 2-7 on page 40) that need the following types of adjustments:

- Latching or unlatching the probe holder (see page 40).
- Installing the wedge-probe assembly onto the probe holder (see page 41).
- Installing the probe holder onto the ChainSCANNER (see page 41).
- Installing or removing the y-axis slide assembly (see page 46).
- Using the y-axis adjustment (see page 44).
- Adjusting the distance between the probes (see page 43).

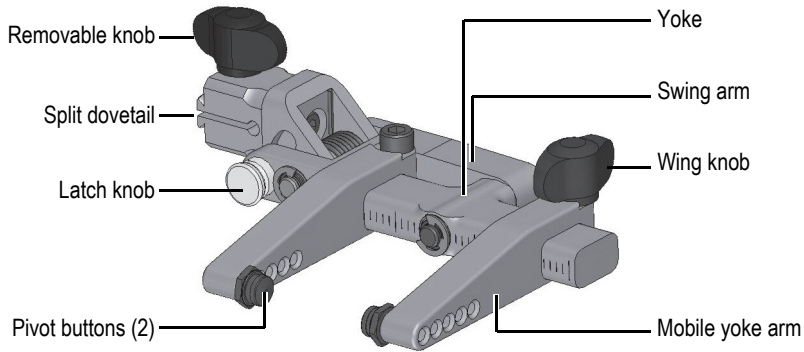

Figure 2-7 Probe-holder assembly parts

Removable knob

The removable knob mounted on the swing arm allows for a precise positioning of the probe holder along the slide assembly or the slide bar (see Figure 2-7 on page 40).

Swing arm

The swing arm holds the yoke and ensures a constant contact pressure between the probe-wedge assembly and the surface being inspected. A latch knob allows for releasing the spring pressure to ease the installation of a wedge-probe assembly (see Figure 2-7 on page 40).

Yoke

The yoke is the U-shaped part holding the wedge-probe assembly. Assembled to the swing arm with bearings, the yoke rotates to maintain the wedge parallel to the surface being inspected. The pivot buttons also allow the wedge to swivel (see Figure 2-7 on page 40).

To latch the swing arm

- ◆ Lift the swing arm upward until the latch knob engages itself with a click. See Figure 2-7 on page 40 for the location of the latch knob.

To unlatch the swing arm

1. Lift and hold the swing arm slightly to remove the spring force on the latch knob.

2. Pull out the latch knob and slowly release the swing arm. See Figure 2-7 on page 40 for the location of the latch knob.

IMPORTANT

For proper contact between the wedge and the part being inspected when performing an inspection, always make sure the swing arm is unlatched.

To install the wedge-probe assembly to the probe holder

1. Ensure the yoke arms have the proper pivot buttons installed to fit the pivot holes in the wedge.
2. Loosen the wing knob one turn.
3. Slide the mobile yoke arm to accept the wedge-probe assembly so that the pivot buttons engage in the wedge holes.
4. Tighten the wing knob.

To install the probe holder onto the ChainSCANNER

1. Collapse the split dovetail by rotating the removable knob clockwise.
2. Insert the probe holder assembly directly into the scanner's dovetail groove.

TIP

The probe holders can be installed either into the slide assembly upper or lower dovetail groove, or directly into the slide bar when the slide assembly is not needed.

3. Clamp the probe holder in place by rotating the removable knob counterclockwise (see Figure 2-9 on page 42).

TIP

Using the split dovetail assembling mode is somewhat counterintuitive, since you have to turn *clockwise* to loosen the mount—in fact, collapsing the split dovetail—and *counterclockwise* to secure the mount—in fact, opening the split dovetail (see Figure 2-8 on page 42).

Once the split dovetail is collapsed, it can be inserted anywhere along the dovetail groove.

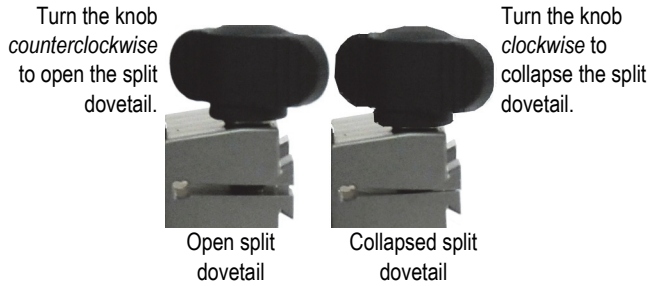

Figure 2-8 Collapsing and opening a split dovetail

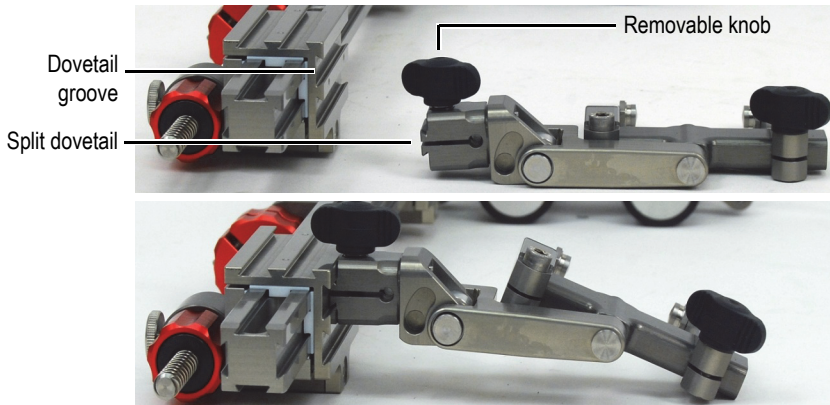

Figure 2-9 Installing a probe holder

To adjust the distance between the probes

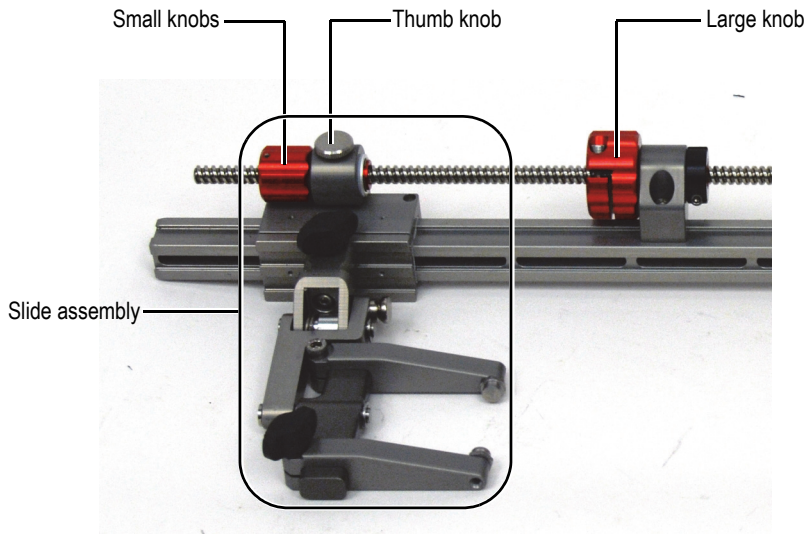

Figure 2-10 Adjusting the distance between the probes

1. Loosen the thumb knob on the slide assembly that you wish to adjust (see Figure 2-10 on page 43).
2. Turn the small knob on the slide assembly while holding the large knob to prevent it from rotating.
3. Tighten the thumb knob.

To move the probe holders together

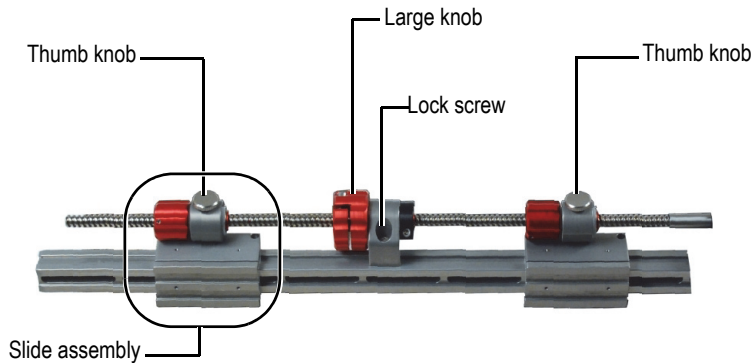

Figure 2-11 The slide bar assembly

1. Ensure that the thumb-knobs, the lock screw, and the large knob are tight.
2. Attach the probe holders to the slide assembly (see “To install the probe holder onto the ChainSCANNER” on page 41).
3. Rotate the large knob to adjust the position of the pair of probes (see Figure 2-11 on page 44).

TIP

In summary, the large red knob is used to move the two slide assemblies together, while each small red knob moves its respective slide assembly. Once the distance between the probes is set, you can then use the large red knob to maintain the probes aligned with the weld during the displacement of the scanner. This is especially useful on larger pipe diameters.

2.4 Changing the Yoke Arm to Fit the Length of a Wedge

When necessary, the yoke arms can be changed to fit the length of different wedge-probe assemblies.

To change the yoke arms

Refer to Figure 2-12 on page 45 for the identification of the parts.

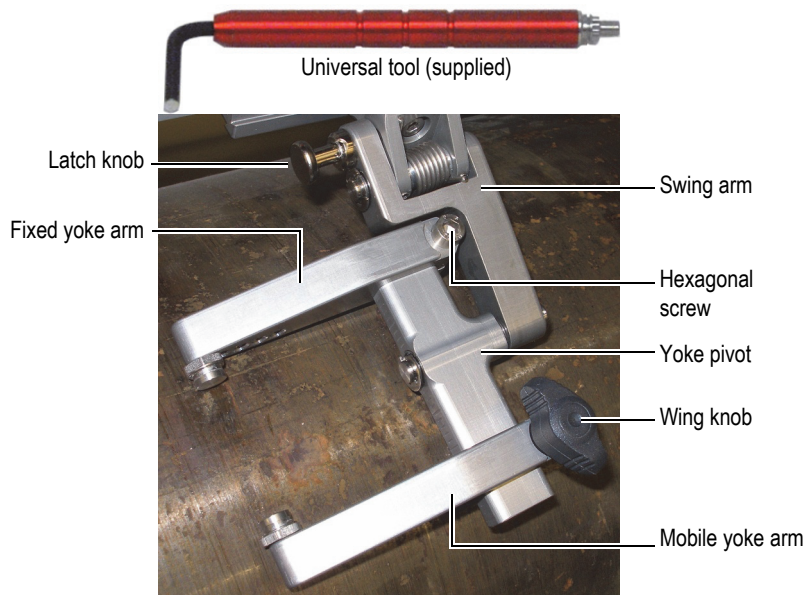

Figure 2-12 Changing the yoke arms

1. Use the latch knob to release the spring tension on the swing arm (see “To unlatch the swing arm” on page 40).
2. Use the supplied universal tool to loosen the hexagonal screw (see Figure 2-12 on page 45).
3. Slide out the fixed yoke arm.
4. Remove the wedge-probe assembly.
5. Install the new fixed yoke arm and tighten the hexagonal screw.
6. Loosen the wing knob to free the mobile yoke arm
7. Remove the mobile yoke arm.
8. Install the wedge-probe assembly (see “To install the wedge-probe assembly to the probe holder” on page 41).
9. Install the new mobile yoke arm and tighten the wing knob.
10. Ensure that the wedge-probe assembly is centered with the yoke pivot.

2.5 Slide Bar, Lead Screw, and Y-Axis Adjustment

To replace the slide bar and the lead screw

1. If an encoder assembly is present, remove it (see “To remove the y-axis encoder” on page 47).
2. Loosen the hexagonal screw on the large knob two turns.
3. Loosen the lock screw.

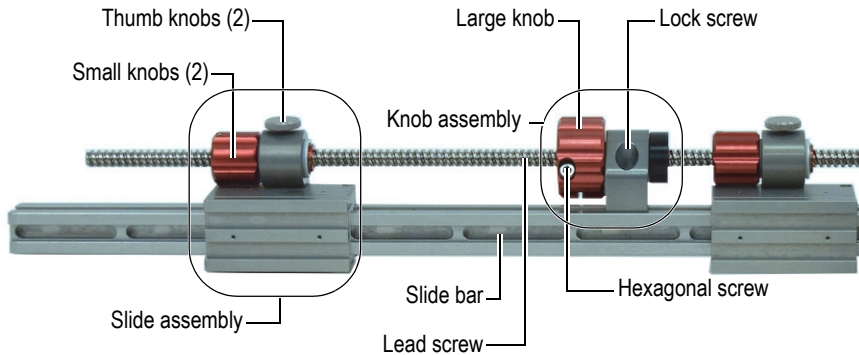

Figure 2-13 Replacing the slide bar and the lead screw

4. Ensure that the thumb knobs are tight and rotate the lead screw to remove it from the assembly.
5. Remove the knob assembly and the slide assemblies from the slide bar.
6. Slide the knob assembly and the slide assemblies onto the new slide bar.
7. Position the knob assembly where desired and tighten the lock screw.
8. Thread the new lead screw into the small knob(s) to the desired position and tighten the screw on the large knob.
9. If required, reinstall the encoder assembly (see Figure 2-13 on page 46).

To removing the y-axis assembly

1. Loosen the lock screw with a hexagonal key (see Figure 2-14 on page 47).

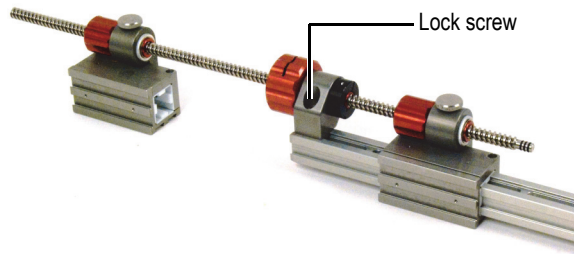

Figure 2-14 Installing or removing the y-axis slide assembly

2. Remove the y-axis slide assembly from the slide bar by sliding it out.

To install the y-axis assembly

1. Install the y-axis slide assembly on the slide bar by sliding it in.
2. Tighten the lock screw with a hexagonal key (see Figure 2-14 on page 47).

2.6 Y-Axis Encoder Removal and Installation

The ChainSCANNER comes equipped with a y-axis encoder. If required, the y-axis encoder can be removed or installed.

To remove the y-axis encoder

1. To remove, loosen the lock screw.
2. Slide the y-axis encoder assembly out of the slide bar and off the lead screw. Expect some resistance because the coupling between the lead screw and the encoder is strong (see Figure 2-15 on page 48).

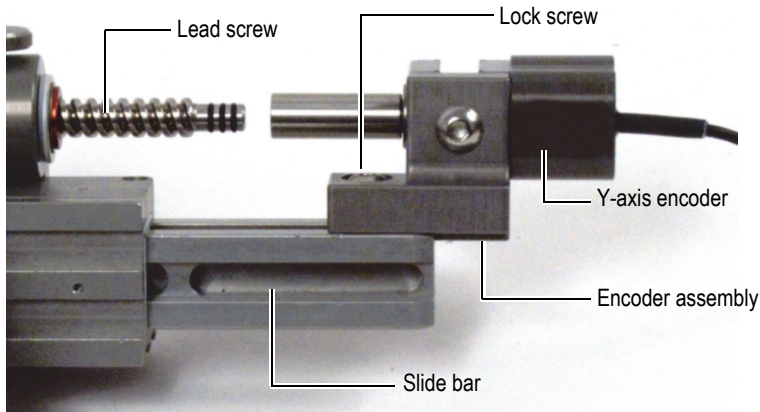

Figure 2-15 Installing or removing the y-axis encoder

To install the y-axis encoder

1. Slide the y-axis encoder assembly in the slide bar and onto the lead screw. Expect some resistance because the coupling between the lead screw and the encoder is strong (see Figure 2-15 on page 48).
2. Tighten the lock screw.

2.7 Umbilical Sheath Strain Relief Assembly

The umbilical cable must be attached to the ChainSCANNER.

To assemble the umbilical cable sheath

1. Slide the annular part of the strain relief over the cable sheath, as shown in Figure 2-16 on page 49.



Figure 2-16 Sliding annular part of the relief connector over the cable sheath

2. Split the cable sheath over a short portion (see Figure 2-17 on page 49).
3. Insert the threaded portion of the strain relief into the internal section of the cable sheath (see Figure 2-17 on page 49).



Figure 2-17 Inserting the threaded portion of the strain relief into the cable sheath

4. Put the cable sheath sections back together.
5. Align and assemble the threaded and annular parts of the strain relief (see Figure 2-18 on page 50).

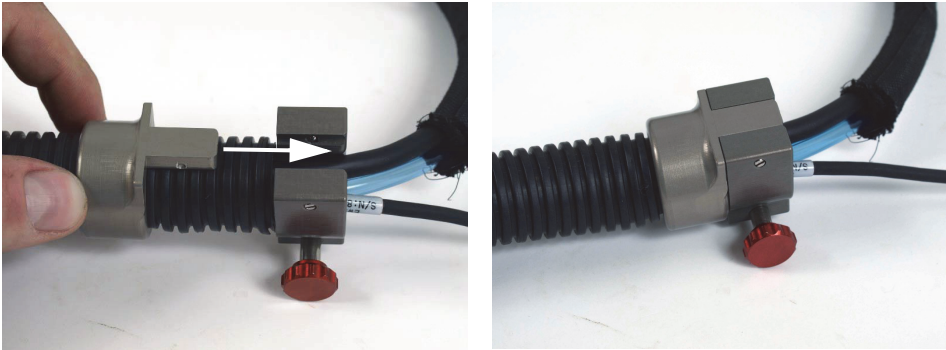

Figure 2-18 Assembling the strain relief connector

6. Connect the LEMO connector of the umbilical cable to the main module of the ChainSCANNER (see Figure 2-19 on page 50).



Figure 2-19 Connecting the umbilical cable to the ChainSCANNER's main module

7. Attach the umbilical cable to the ChainSCANNER using the thumb screw (see Figure 2-20 on page 51).



Figure 2-20 Attaching the umbilical cable to the ChainSCANNER

The procedure is now complete (see Figure 2-21 on page 52).

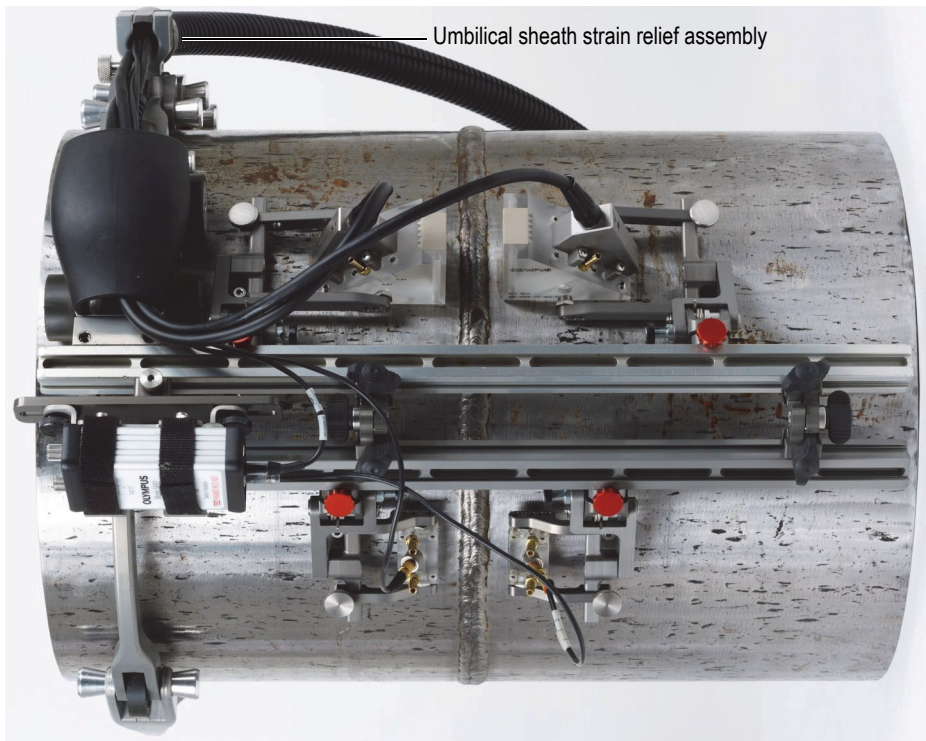

Figure 2-21 The ChainSCANNER with four-probe kit installed

2.8 Optional Four-Probe Kit

The optional four-probe kit (P/N: CHAINSCAN-A-4PROBE [U8775128]) allows the use of four probes on large pipes. The four-probe assembly adapts to the pipe circumference through the pivots of the additional frame bar pivots (see Figure 2-22 on page 53).

The optional four-probe kit includes the following:

- An additional bar
- A pair of frame bar pivots to adapt to pipe curvature
- A pair of probe holders for TOFD or pulse/echo probes
- A bracket for pre-amplifier mounting

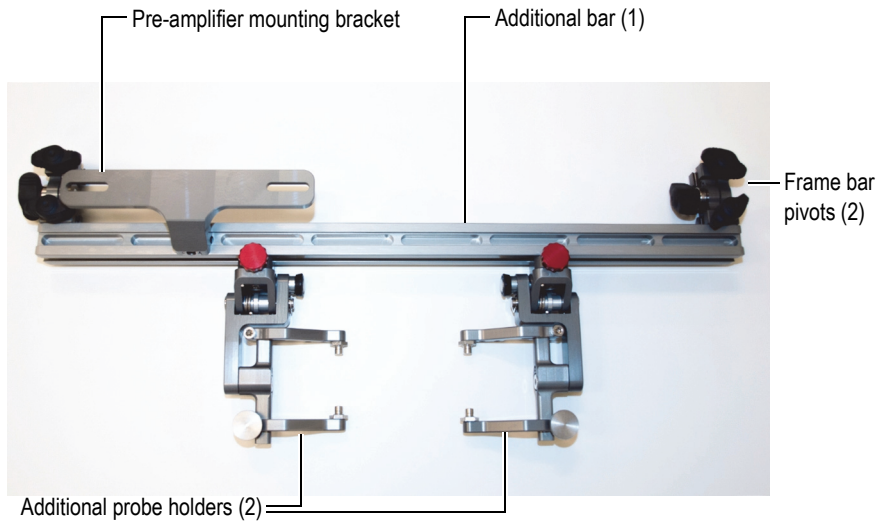

Figure 2-22 The optional four-probe kit

For an example of the ChainSCANNER, four-probe configuration, see Figure 2-23 on page 54).

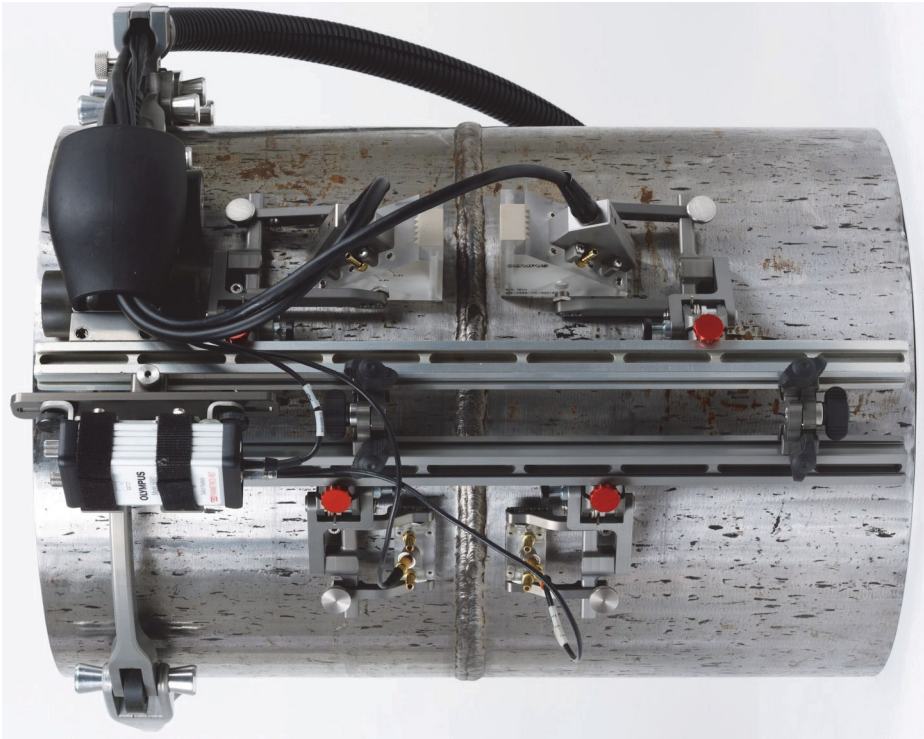

Figure 2-23 The ChainSCANNER, four-probe configuration

2.9 Optional Mouse Conversion Kit

The main module of the ChainSCANNER can be used as a mouse scanner, that is to say, without the chain components. This option allows the scanner to be held against a ferromagnetic surface by a set of magnetic wheels instead of by the chain component. This configuration is used for pipe inspections of 965 mm (38 in.) OD up to flat surface as well as longitudinal weld inspections of large diameter pipes.

The mouse conversion kit (P/N: CHAINSCAN-A-MOUSE [U8750037]) includes the following (see Figure 2-24 on page 55):

- Four magnetic wheels
- A parking-brake handle

- A mouse-dedicated dovetail attachment

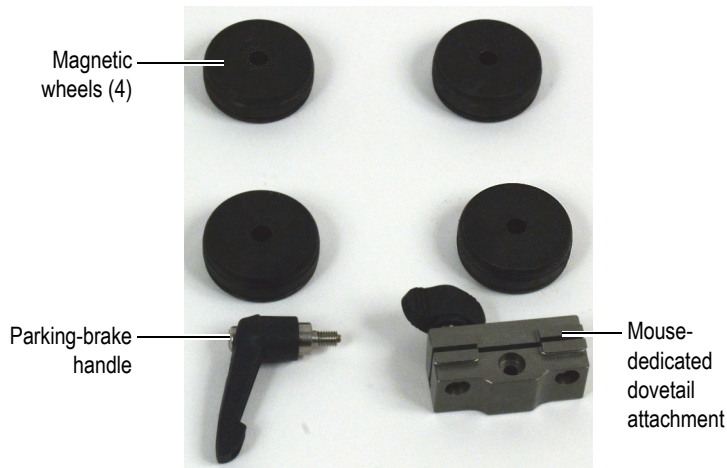

Figure 2-24 The optional mouse conversion kit

To install the optional mouse conversion kit

1. Remove the buckle assembly and chain links, if any, attached to the scanner.
2. Remove the main module assembly from the slide bar (see “To couple the main module and the slide bar” on page 34).
3. For an easier manipulation, remove the encoder umbilical cable from the main module (see “To install or release the encoder umbilical cable” on page 36).

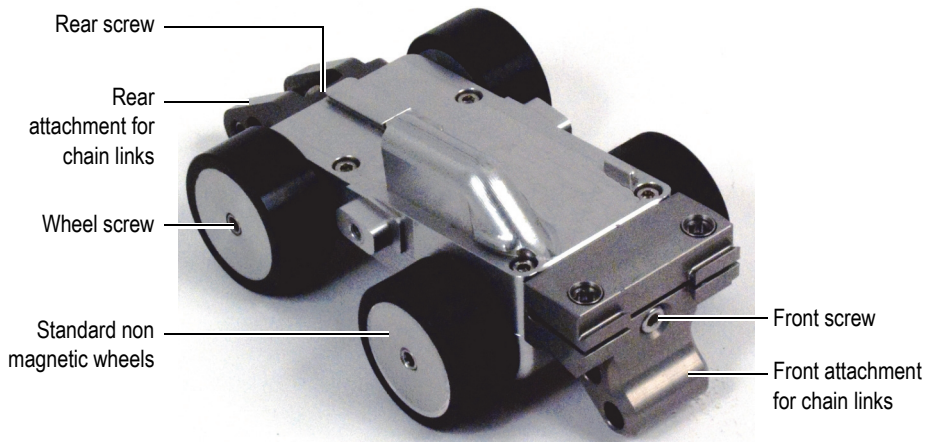

Figure 2-25 The main module equipped with the chain attachment

4. Use a hexagonal key or the supplied universal tool to unscrew the front screw securing the mouse front attachment for chain links (see Figure 2-25 on page 56).
5. Use a hexagonal key or the provided universal tool to unscrew the rear screw securing the mouse rear attachment for chain links.
6. Use a hexagonal key or the supplied universal tool to install the mouse-dedicated dovetail attachment for the mouse scanner (see Figure 2-26 on page 57).
7. Use a hexagonal key or the supplied universal tool to install the parking brake.
The newer version of the main module comes already equipped with an integrated break system. If your main modules is thus equipped, skip this step.

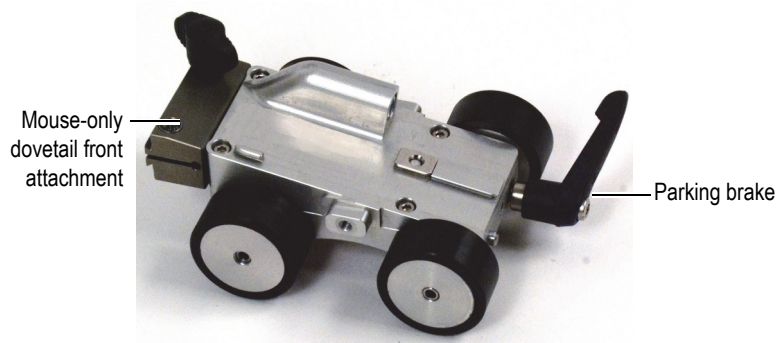

Figure 2-26 Mouse-dedicated dovetail front attachment and parking brake

8. To remove wheels, hold one of the wheel with your hand, and use a hexagonal key or the supplied universal tool to unscrew the opposite wheel screw (see Figure 2-27 on page 57).

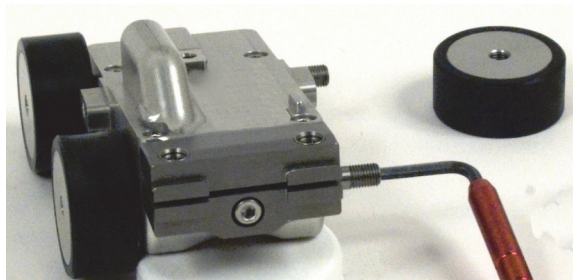

Figure 2-27 Using the supplied universal tool to install the magnetic wheels

9. Install the magnetic wheels using the hexagonal key or the supplied universal tool to secure it in place (see Figure 2-28 on page 58).
10. Reverse the procedure to transform the mouse scanner back into the ChainSCANNER configuration.

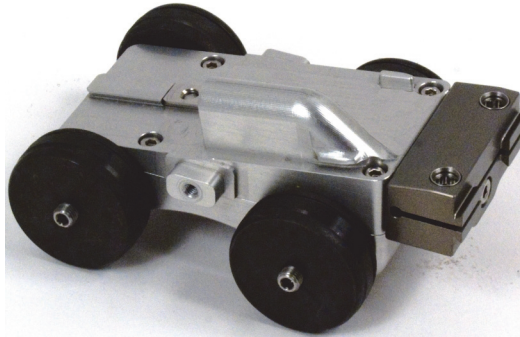

Figure 2-28 Magnetic wheels to hold the mouse scanner on ferromagnetic surface

2.10 Optional 20-Centimeter Bar and Lead Screw Kit

The 20-centimeter bar and lead-screw kit (P/N: CHAINSCAN-A-SBAR [U8775129]) allows for a very compact configuration of the scanner. It can be used with the mouse conversion kit (P/N: CHAINSCAN-A-MOUSE [U8750037]) as shown in Figure 2-29 on page 59, as well as a with the chain assembly (see Figure 2-30 on page 60). These configurations are convenient when minimum encumbrance is required.

The 20-centimeter bar and lead-screw kit includes the following:

- One 20 cm (8 in.) slide bar
- One 20 cm (8 in.) lead screw

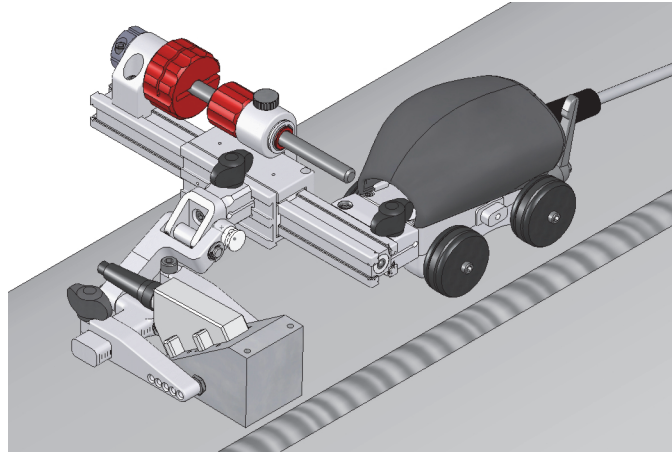

Figure 2-29 The 20-centimeter bar and lead screw option—mouse scanner

The 20-centimeter bar holds one probe holder. The probe holder can be attached directly into the dovetail groove of the 20 cm slide bar, or into one of the two dovetail grooves of the y-axis adjustment assembly.

To use the y-axis adjustment on the 20 cm slide bar, retrieve the large red knob assembly and one of the two small red knob assemblies from the ChainSCANNER standard configuration (see “To replace the slide bar and the lead screw” on page 46) and use the 20 cm lead screw instead of the standard lead screw.

NOTE

The 20 cm lead screw cannot be used with the y-axis encoder.

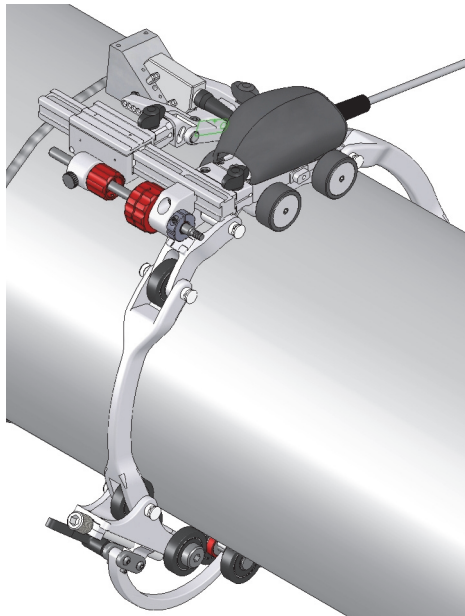

Figure 2-30 The 20-centimeter bar and lead-screw option—ChainSCANNER

3. Preparing the ChainSCANNER for an Inspection

Several connections and adjustments must be made to prepare the ChainSCANNER for an inspection.

To prepare the ChainSCANNER for an inspection

1. Set up the main module (see “Main Module Setup and Connection” on page 33)
2. Set up the chain (see “ChainSCANNER Setup” on page 38)
3. Position the ChainSCANNER on the pipe to be inspected.
4. Hook the buckle arm either on the catch link, or on the main module rear attachment, depending on the pipe outside diameter (see “To add or remove a link on the ChainSCANNER” on page 38).
5. Adjust the tension of the ChainSCANNER by turning the adjustment screw (see Figure 3-1 on page 62).
6. Engage the buckle latch to close the ChainSCANNER around the pipe.



CAUTION

Extreme over-tensioning can reduce the life of the buckle components.



CAUTION

When the inspection is finished, release the tension on the ChainSCANNER to avoid flattening of the rubber wheels.

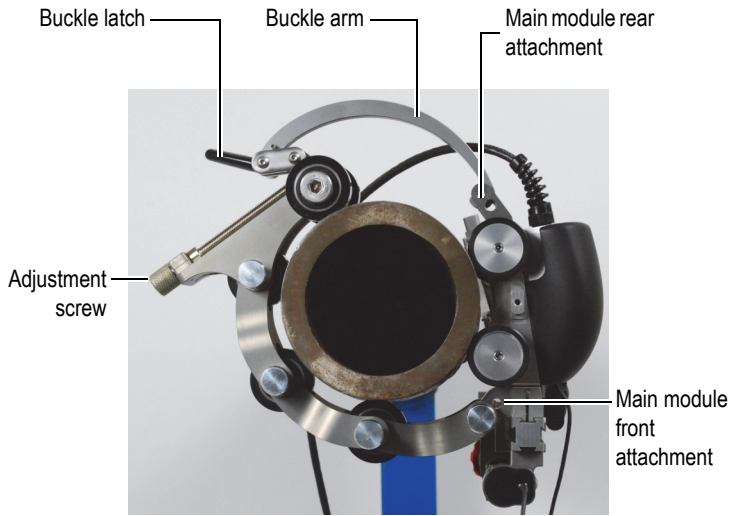

Figure 3-1 Closing the chain around the pipe

7. When preparing the ChainSCANNER for larger diameter pipes, the scanner's position must be adjusted, to avoid helicoidal movement as much as possible. Otherwise, go directly to step 8.

For larger diameter pipes, adjust the scanner's position. Do the following:

- a) Measure the distance between the side of the wheel of the module and the weld (for example, 100 mm).
- b) Rotate the module 180° around the pipe.
- c) Measure again the distance between the side of the wheel of the module and the weld (for example, 120 mm).
- d) Unlatch the chain mechanism while keeping pressure on the latch, to make sure that the ChainSCANNER stays at its current position.
- e) Move the module to position it at the same distance to the weld as measured in step 7.a (as per this example, we would move the module 20 mm toward the weld).
- f) Latch the chain mechanism.
- g) Return the ChainSCANNER to its original position (180°).
- h) Repeat steps 7.a to 7.g until the position is repeatable within an acceptable range.

8. Adjust the probe or transducer position (see “To adjust the distance between the probes” on page 43).
9. Connect the appropriate cables and tubes to the probes and wedge.
10. Pass the probe cables and irrigation tubes under the module’s black ergonomic cover (see Figure 3-2 on page 63).

IMPORTANT

Failure to pass the cables and tubes underneath the module’s ergonomic cover can result in lack of pressure between the wedge and the part being inspected.

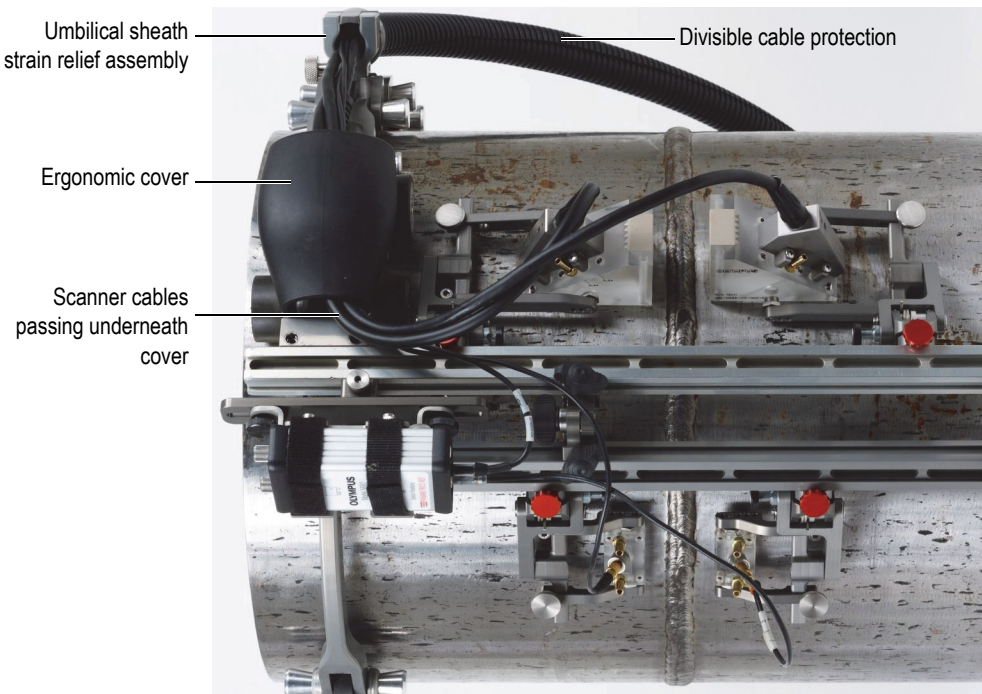

Figure 3-2 Cables passing underneath the module’s ergonomic cover (model equipped with Four-Probe kit shown)

11. Cover the cables and tubes with the supplied divisible cable protection.

12. Attach the divisible cable protection to the chain to avoid excessive stress on the cables and tubes connections (see “Umbilical Sheath Strain Relief Assembly” on page 48).

4. Operating the ChainSCANNER

The ChainSCANNER is designed to be used manually. It is simple to operate.

To operate the ChainSCANNER

1. Fasten the scanner around the pipe to be inspected (see “To prepare the ChainSCANNER for an inspection” on page 61).
2. Center the inspection area between the probes (see “To move the probe holders together” on page 44 and Figure 4-1 on page 65).

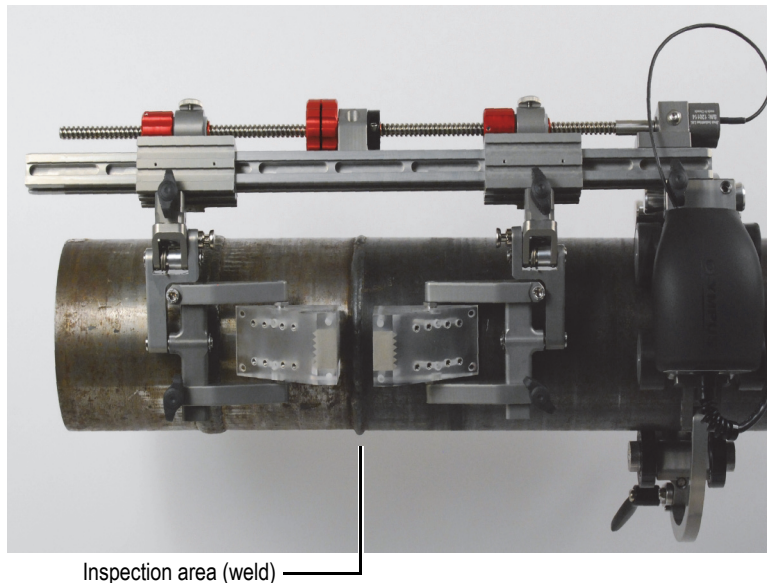

Figure 4-1 Center the inspection area between the probes

IMPORTANT

All wedge-probe assemblies must be correctly positioned on the surface being inspected.

IMPORTANT

All carbide wear-pins should be flush with the wedge surface (see Appendix B, “Wedge-Probe Assembly Maintenance” on page 89).

IMPORTANT

For proper contact between the wedge and the part being inspected when performing an inspection, always make sure that the swing arm is unlatched.

3. Simply push or pull the scanner in the desired inspection direction.

5. Maintenance

This chapter deals with the basic maintenance that an operator can apply to the ChainSCANNER. The maintenance operations explained as follows helps keep the product in good physical and working condition. Due to its design, the ChainSCANNER requires only a minimum of maintenance. This chapter covers preventive maintenance and unit cleaning.

5.1 Preventive Maintenance

The ChainSCANNER does not require preventive maintenance. Only a regular inspection of the product is recommended to ensure that the ChainSCANNER functions correctly.

5.2 Unit Cleaning

The ChainSCANNER external surfaces can be cleaned when needed. This section provides the procedure for the appropriate cleaning of the product.

To clean the unit

1. Ensure the unit is turned off by removing the source of power.
2. Disconnect all cables.
3. To bring the instrument back to its original finish, clean the housing with a soft cloth.
4. To remove persistent stains, use a damp cloth with a soft, soapy solution. Do not use abrasive products or powerful solvents that could damage the finish.
5. Wait until the instrument dries completely before connecting the cables.

6. Spare Parts and Optional Kits

The ChainSCANNER features numerous parts, components, and accessories. Individual spare parts and parts kits are listed in tables.

6.1 Spare Parts

An exploded view and a list of spare parts for the ChainSCANNER are provided in Figure 6-1 on page 70 and Table 1 on page 70 for the frame and chain, and in Figure 6-2 on page 73 and Table 2 on page 74 for the cart.

Note: Items 33–38 are for legacy (old) encoders with serial numbers 128982 and lower. Item 11 is the new encoder; serial numbers 128983 and higher.

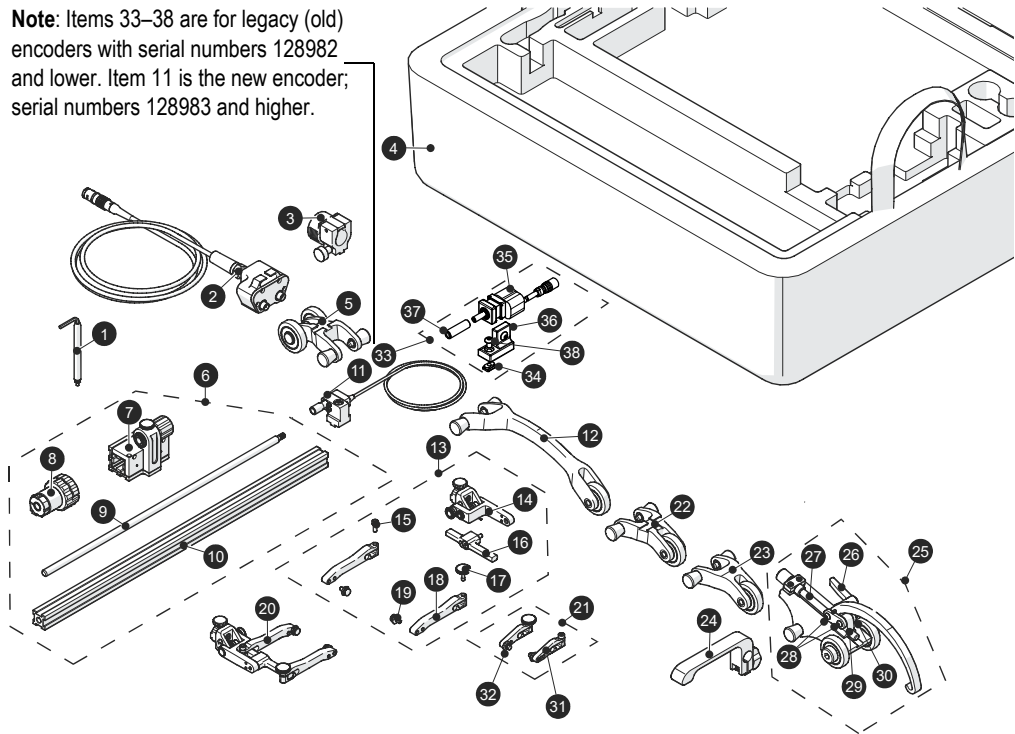

Figure 6-1 ChainSCANNER frame and chain — exploded view

Table 1 ChainSCANNER spare parts — frame and chain

Drawing item	Part number	Marketing number	Description
N/A	U8750041	CHAINSCAN-XY38	ChainSCANNER-XY38: Hand scanner for pipe inspection with encoded x-axis and y-axis for pipe outside diameters from 45 mm to 965 mm (1.75 in. to 38 in.). Includes two spring-loaded arms, two yokes for TOFD/PE UT probes, two yokes for phased array probes, 5 m encoder cable for OmniScan, 5 m divisible cable protection, irrigation tubes, and fittings. Probes and wedges are not included.
1	U8775130	CHAINSCAN-A-TOOL	ChainSCANNER universal tool

Table 1 ChainSCANNER spare parts – frame and chain (continued)

Drawing item	Part number	Marketing number	Description
2	U8775162	CHAINSCAN-A-CABLE01	ChainSCANNER encoder cable with plastic cover handle (P/N: U8150425). Cable is 5 m long with a LEMO connector compatible with OmniScan MX2 and SX.
3	U8150357	CHAINSCAN-SP-CABLECLAMP	Clamp, PMA flex cable
4	Q8301078	N/A	Case for ChainSCANNER
5	U8150587	N/A	ChainSCANNER catch link
6	Q8301079	N/A	Manual y-axis adjuster assembly
7	U8909359	N/A	Slide assembly with small knob
8	U8775206	CHAINSCAN-A-MAINKNOB	Main large red knob for y-axis indexation on ChainSCANNER. Features mounting holes for crank handle installation.
9	U8775146	CHAINSCAN-A-LSCREW38	ChainSCANNER 38 cm lead screw to be used on the XY option with the longitudinal “Y” encoder
10	U8830732	CHAINSCAN-A-FBAR450	Probe-holder bar, 450 mm dovetail slide
11	Q8301081	N/A	New encoder assembly for longitudinal “Y” axis, with magnetic dovetail mount. Resolution: 1440 counts/revolution NOTE: This item is for encoders with serial numbers 128983 and higher. For serial numbers 128982 and lower, see legacy (old) encoder items 33–38.
12	U8750042	CHAINSCAN-A-LGLINK	ChainSCANNER long link. Required on pipes with OD greater than 244 mm (9.6 in.)
13	U8830730	CHAINSCAN-A-PH-LEFT	Probe holder assembly, wide (left)
14	Q8301080	N/A	Probe holder subassembly, fixed joint
15	Q8300568	N/A	Screw, SHCS, M4-0.7 × 10 mm, stainless steel
16	Q8301041	N/A	Bar for wide yoke
17	Q7750010	N/A	Single thumb screw for probe holder arm
	U8831554	N/A	Package of 4 thumb screws for probe holder arm
18	Q8300578	N/A	Long arm for wide probe holder (flat contact)
19	U8775198	CHAINSCAN-A-BUTTON-8MM	8 mm diameter button for ChainSCANNER arm.
17+18+19	U8775261	CHAINSCAN-A-ARM-LPA	Large, 63.5 mm long arm set for ChainSCANNER with 8 mm buttons for PA probe. IMPORTANT NOTE: Will fit on original thicker rear member with 17.8 mm × 10.6 mm cross section.

Table 1 ChainSCANNER spare parts – frame and chain (continued)

Drawing item	Part number	Marketing number	Description
17+18+19	U8775262	CHAINSCAN-A-ARM-SPA	Slim, 63.5 mm long arm sets for ChainSCANNER with 8 mm buttons for PA probe. IMPORTANT NOTE: Will fit on newer slim rear member with 17.8 mm × 10.6 mm cross section.
20	U8830731	CHAINSCAN-A-PH-RIGHT	Probe holder assembly, wide (right)
21	U8775264	CHAINSCAN-A-ARM-SUT	Slim, 27.9 mm arm set (short) for ChainSCANNER with 5 mm buttons for UT probe. IMPORTANT NOTE: Will fit on newer slim rear member with 8.7 mm × 6.5 mm cross section. Includes item 32 (Q7750009)
17+31+32	U8775263	CHAINSCAN-A-ARM-LUT	Large, 27.9 mm long arm sets for ChainSCANNER with 5 mm buttons for UT probe. IMPORTANT NOTE: Will fit on original thicker rear member with 17.8 mm × 10.6 mm cross section.
17+31+32	U8775294	CHAINSCAN-A-PH-UT-LEFT	One UT probe holder compatible with ChainSCANNER (left sided). Can accommodate up to 45 mm wide wedge. Fork arms are 37 mm long and have 5 mm diameter buttons.
22	U8150457	CHAINSCAN-SP-SHORTLINKDOVETAIL	ChainSCANNER short link dove tail
23	U8775127	CHAINSCAN-A-SLINK	ChainSCANNER short link. Required on pipes with OD less than 244 mm (9.6 in.)
24	U8775259	CHAINSCAN-A-HANDLE	Handle for ChainSCANNER. To be mounted on dovetail links or frame bar
25	U8775276	N/A	Buckle assembly
26	Q8300131	N/A	ChainSCANNER modified adjustment handle EA164
27	Q1500157	N/A	Adjustment screw for buckle
28	Q8300132	N/A	M4-0.7 × 25 mm stainless steel BHCS screw
29	Q1500158	N/A	Buckle bracket
30	U8909924	N/A	Nut for buckle bracket
31	U8775199	CHAINSCAN-A-BUTTON-5MM	5 mm diameter button for short arm item 21 (U8775264)
32	Q7750009	N/A	Single, short arm (flat contact) [see description of item 21 (U8775264)]

Table 1 ChainSCANNER spare parts – frame and chain (continued)

Drawing item	Part number	Marketing number	Description
33	U8775145	CHAINSCAN-SP-ENC	Legacy (old) encoder assembly for longitudinal “Y” axis. Resolution: 1024 counts/revolution NOTE: Only for encoder serial numbers 128982 and lower.
34	U8909912	CHAINSCAN-SP-NUTDOVETAIL	Dovetail nut for legacy encoder serial numbers 128982 and lower
35	U8830489	N/A	“Y” encoder (no base) for legacy encoder serial numbers 128982 and lower
36	U8150449	CHAINSCAN-SP-BRACKETENC MOUNT	Mounting bracket for legacy encoder serial numbers 128982 and lower
37	U8150448	CHAINSCAN-SP-COUPLINGENC	Coupling for legacy encoder serial numbers 128982 and lower
38	U8150450	N/A	Screw, BHCS M5-0.8 × 8 mm stainless steel, for legacy encoder serial numbers 128982 and lower

**Figure 6-2 ChainSCANNER cart – exploded view**

Table 2 ChainSCANNER spare parts – cart

Drawing item	Part number	Marketing number	Description
N/A	U8831574	CHAINSCAN-SP-FULLCART	ChainSCANNER main cart replacement assembly. Includes X encoder, cart module, shafts, 4 × plastic wheels, front and back mounting plates. Does not include encoder module and cable (P/N: U8775162).
1	Q8300568	N/A	Screw for tail kit, SHCS, M4-0.7 × 10 mm, stainless steel
2	U8831177	N/A	ChainSCANNER tail
3	Q8301073	N/A	Removable knob, fixed handle
4	U8150425	CHAINSCAN-SP-BUGGYCOVER	Plastic buggy cover for ChainSCANNER
5	U8775224	CHAINSCAN-SP-CART	ChainSCANNER main cart replacement module. Includes X encoder, cart module and shafts. NOTE: The encoder inside the cart is not available as an individual part.
6	U8779383	CHAINSCAN-A-MWHEEL	Magnetic wheel for ChainSCANNER
7	U8775189	CHAINSCAN-A-PWHEEL	Plastic wheel for ChainSCANNER
8	U8775167	CHAINSCAN-A-KNOB	Removable thumb screw for ChainSCANNER
9	Q8301075	N/A	ChainSCANNER nose kit
10	Q8301076	N/A	Screw for nose kit, SHCS, M4-0.7 × 12 mm, stainless steel

6.2 Optional Kits and Parts

Table 3 on page 74 lists optional kits and parts that are available to adapt the ChainSCANNER for diverse inspection needs.

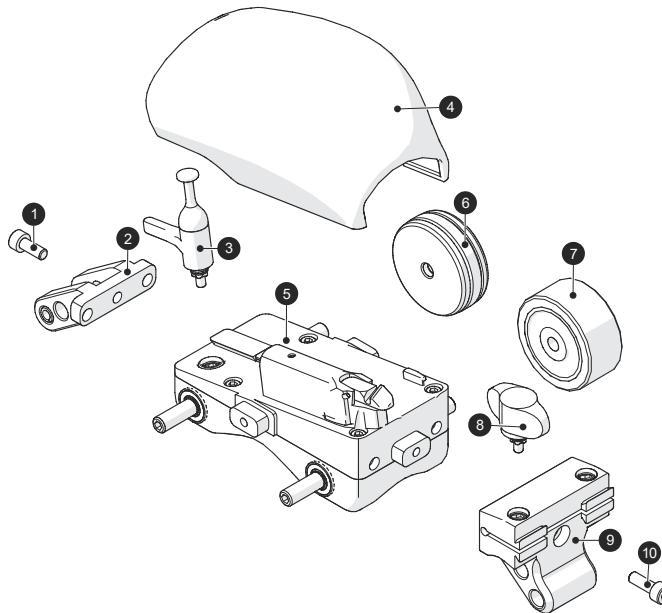
Table 3 ChainSCANNER optional kits and parts

Part or kit image	Part number	Marketing number	Description
	U8775205	CHAINSCAN-A-CRANK	Crank handle for y-axis indexation on ChainSCANNERs. NOTE: Will only fit if the main red knob of the ChainSCANNER has the mounting holes. If not, a knob (P/N: CHAINSCAN-A-MAINKNOB [U8775206]) must also be ordered.

Table 3 ChainSCANNER optional kits and parts (*continued*)

Part or kit image	Part number	Marketing number	Description
	U8779370	CHAINSCAN-SP-BASIC	Basic spare parts kit for the ChainSCANNER including: Lead screw and lever for buckle, wedge pivot buttons, dovetail nuts, specific tool, plastic wheel, and various types of screws, including wing screws.
	U8909207	N/A	ChainSCANNER basic hardware, maintenance
	U8130022	CHAINSCAN-SP-PMASCREW	Thumb screw and dovetail nut kit for ChainSCANNER PMA flex umbilical attachment.
	U8775210	CHAINSCAN-A-STABILIZER	ChainSCANNER arm stabilizer kit. Includes a magnetic wheel block and the holder to mount on the scanner arm.
	U8775128	CHAINSCAN-A-4PROBE	Extra part package to allow inspection using 4 probes on the ChainSCANNER. Includes: 2 side frame arms, one 450 mm bar, 2 magnetic wheels, 2 handles, and 2 TOFD yokes.
	U8750037	CHAINSCAN-A-MOUSE	Extra part package to allow the ChainSCANNER to be used as a mouse scanner with magnetic wheels holding system (instead of chain links). Includes front attachment part, brake handle, and 4 magnetic wheels.
	U8775129	CHAINSCAN-A-SBAR	20 cm long probe holder bar and screw kit
	U8775161	CHAINSCAN-A-FBAR550	ChainSCANNER 550 mm long frame bar
	U8775178	CHAINSCAN-A-YCABLE1M	Extension cable for ChainSCANNER Y encoder, 1 m long.

Table 3 ChainSCANNER optional kits and parts (continued)





Part or kit image	Part number	Marketing number	Description
	U8775190	CHAINSCAN-A-TRANSVERS	Bracket to pivot a ChainSCANNER yoke from 0° to 90°
	U8775196	CHAINSCAN-A-SWNOSE	Swivel nose to be installed on the front of a ChainSCANNER. Suitable for holding one probe holder bar and allowing rotation along the long axis of the bar.
	U8775197	CHAINSCAN-A-FBAR100	10 cm long probe holder bar for ChainSCANNER.
	U8775200	CHAINSCAN-A-ARM-LD8MM	Large dropped arm sets for ChainSCANNER with 8 mm buttons.
N/A	U8780008	CFU03	Electric water pump with flow control valve and power supply (100 VAC to 240 VAC input to 24 VDC output). Includes the following tubes and fittings: <ul style="list-style-type: none"> • 3.3 m (10 ft) long, 9.5 mm (3/8 in.) ID tube for pump inlet with filter and check valve • 3.3 m (10 ft) long, 5 mm (3/16 in.) ID tube and Y adaptor for pump outlet
N/A	U8775153	WTR-SPRAYER-4L	Portable manual couplant feed unit. Manual water pump used to supply couplant to wedges during automated inspection. Includes: reservoir capacity of 4 L, flow valve, irrigation tube (8 mm OD, 5 mm ID) and sling for transportation.
N/A	U8775001	WTR-SPRAYER-8L	Portable manual couplant feed unit. Manual water pump used to supply couplant to wedges during automated inspection. Includes: reservoir capacity of 8 L, flow valve, irrigation tube (8 mm OD, 5 mm ID) and sling for transportation.
N/A	U8120042	TRPP-5810	Ultrasonic pulser and preamplifier dedicated for TOFD applications. Can support one or two pairs of TOFD probes. It features 200 V, 40 dB gain, 12 VDC input operation. 500 kHz to 30 MHz bandwidth. Kit includes: 5 m power supply cable (120 VAC to 240 VAC input to 12 VDC output), and hard carrying case.

Table 3 ChainSCANNER optional kits and parts (continued)

Part or kit image	Part number	Marketing number	Description
N/A	U8775114	TRPP-5810-INST	Ultrasonic pulser and preamplifier kit dedicated for TOFD applications. Can support one or two pairs of TOFD probes. It features 200 V, 40 dB gain, 12 VDC input operation and 500 kHz to 30 MHz bandwidth. Kit includes: 5 m power supply cable linking to OmniScan, 5 m power supply cable (120 VAC to 240 VAC input to 12 VDC output), 4 × 0.6 m UT cables with LEMO-00 to Microdot connectors for probes, 4 × 5 m UT cables with LEMO-00 to LEMO-00 connectors to connect to instrument, brackets to attach TRPP 5810 to HSMT type scanners, and hard carrying case.
N/A	U8775201	OMNI-A2-ADP20	Scanner interface adaptor to connect scanner encoder cables with DE15 connector to OmniScan MX2 with LEMO connector scanner interface.
N/A	U8780329	OMNI-A-ADP27	Scanner interface adaptor to connect scanner encoder cables with LEMO connector to OmniScan MX with DE15 connector scanner interface.
N/A	U8769010	C1-LF-BXM-0.3M	0.3 m (12 in.) long adapter, LEMO female to Bendix male, linking LEMO encoder cable to FOCUS LT.
N/A	U8767107	C1-DE15F-BXM-0.30M	305 mm (12 in.) long adapter, DE-15 female to Bendix male, linking DE-15 encoder cable to FOCUS LT.

7. ChainSCANNER Specifications

This chapter contains the specifications for the ChainSCANNER.

7.1 General and Operating Environment Specifications

Table 4 General specifications

Parameter	Value
Pipe range outside diameter	45 mm (1.75 in.) to 965 mm (38 in.)
Main module dimension	7.5 cm × 8.4 cm × 11.4 cm (2.95 in. × 3.30 in. × 4.50 in.)
Weight	960 g (2.1 lb) (Main module only)
X-axis encoder	Resolution: 19.2 steps/mm ±0.15 steps/mm quadrature decode Power: 5 VDC 100 mA Frequency: 0–2 kHz (for a maximum displacement velocity per second of 10 cm [4 in.]
Y-axis encoder	Resolution: 226.8 steps/mm ±0.15 steps/mm quadrature decode Power: 5 VDC 25 mA Frequency: 0–25 kHz (for a maximum displacement velocity per second of 10 cm [4 in.]

Table 5 Operating environment specifications

Parameter	Value
Operating temperature	5 °C to 50 °C (41 °F to 122 °F)
Storage temperature	-30 °C to 60 °C (-22 °F to 140 °F)
Relative humidity (RH)	Max. 80 % RH noncondensing
Wet location	Yes
Altitude	Up to 2000 m
Outdoor use	Yes
Pollution level	1
IP rating	Waterproof (designed to meet IP67)

7.2 Connector Reference

ChainSCANNERS sold after July 2013 come standard with the LEMO connector which is compatible with the OmniScan MX2 and SX instruments. For use with a different instrument, an optional adaptor is required (see Table 6 on page 80).

Table 6 Required encoder cable adaptor

Scanner connector	Instrument			
	OmniScan MX	OmniScan MX2	OmniScan SX	TomoScan FOCUS LT
LEMO (from July 2013 onward)	Omni-A-ADP27 [U8780329]	—	—	C1-LF-BXM-0.3M [U8769010]
DE15 (Prior to July 2013)	—	Omni-A2-ADP20 [U8775201]	Omni-A2-ADP20 [U8775201]	C1-DE15F-BXM-0.30M [U8767107]

Figure 7-1 on page 81 and Table 7 on page 81 contain the pinout for the LEMO connector used on the OmniScan MX2 model.

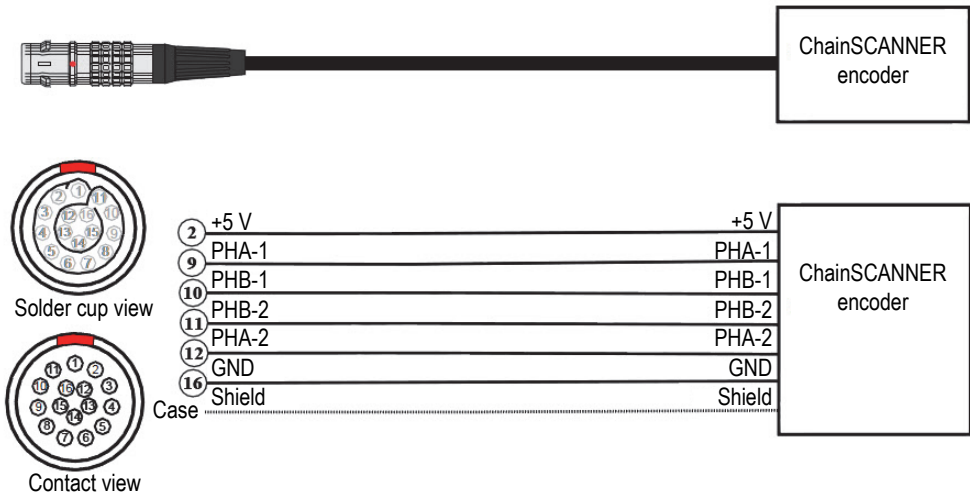

Figure 7-1 LEMO connector pinout diagram

Table 7 OmniScan MX2 pinout for the scanner interface LEMO connector

Pin	Signal	Description
2	+5 V	External power supply
9	PhA axis 1	Encoder 1: phase A
10	PhB axis 1	Encoder 1: phase B
11	PhB axis 2	Encoder 2: phase B
12	PhA axis 2	Encoder 2: phase A
16	GND	Ground
Case	Shield	Ground earthing

Appendix A: ChainSCANNER Sizing Charts

The following ChainSCANNER sizing tables are a reference to determine an appropriate number of links for a given pipe size. There is a metric chart and a U.S. Customary unit chart. Each cell in the chart shows a range of pipe outside diameters—pipe circumferences are between parenthesis. The number at the top of the column indicates how many short links are required while the number at the left of the row indicates how many long links are required.

Table 8 ChainSCANNER sizing chart (inches)

		Number of short links (Ordering number: ChainScan-A-SLink)				
		0	1	2	3	4
Number of long links (Ordering number: ChainScan-A-LgLink)	0	N/A	1.6–3.5 (5.1–11.0) ^a	3.4–4.4 (10.8–13.9)	4.3–5.3 (13.6–16.7)	5.2–6.2 (16.2–19.3)
	1	N/A	N/A	N/A	N/A	N/A
	2	N/A	N/A	9.6–9.9 (30.2–31.0)	9.8–10.6 (30.7–33.4)	10.5–11.4 (33.1–35.8)
	3	9.9–10.8 (31.2–33.8)	10.7–11.5 (33.6–36.1)	11.4–12.3 (35.9–38.5)	12.2–13.0 (38.2–40.9)	12.9–13.8 (40.6–43.4)
	4	12.3–13.1 (38.5–41.2)	13.0–13.9 (40.9–43.6)	13.8–14.6 (43.2–46.0)	14.5–15.4 (45.6–48.4)	15.3–16.2 (48.0–50.9)
	5	14.6–15.5 (45.9–48.7)	15.4–16.2 (48.2–51.0)	16.1–17.0 (50.6–53.5)	16.9–17.8 (53.1–55.9)	17.7–18.6 (55.5–58.4)
	6	16.9–17.9 (53.2–56.1)	17.7–18.6 (55.6–58.5)	18.5–19.4 (58.0–60.9)	19.3–20.2 (60.5–63.4)	20.0–21.0 (62.9–65.9)
	7	19.3–20.2 (60.6–63.5)	20.1–21.0 (63.0–66.0)	20.8–21.8 (65.5–68.4)	21.6–22.6 (67.9–70.9)	22.4–23.3 (70.4–73.3)
	8	21.7–22.6 (68.1–71.0)	22.4–23.4 (70.5–73.4)	23.2–24.2 (72.9–75.9)	24.0–24.9 (75.4–78.3)	24.8–25.7 (77.9–80.8)
	9	24.0–25.0 (75.5–78.4)	24.8–25.7 (77.9–80.9)	25.6–26.5 (80.4–83.3)	26.4–27.3 (82.9–85.8)	27.2–28.1 (85.3–88.3)
	10	26.4–27.3 (82.9–85.9)	27.2–28.1 (85.4–88.3)	28.0–28.9 (87.8–90.8)	28.7–29.7 (90.3–93.3)	29.5–30.5 (92.8–95.8)
	11	28.8–29.7 (90.4–93.4)	29.5–30.5 (92.8–95.8)	30.3–31.3 (95.3–98.3)	31.1–32.1 (97.8–100.8)	31.9–32.9 (100.2–103.3)
	12	31.1–32.1 (97.8–100.9)	31.9–32.9 (100.3–103.3)	32.7–33.7 (102.7–105.8)	33.5–34.5 (105.2–108.2)	34.3–35.3 (107.7–110.7)
	13	33.5–34.5 (105.3–108.3)	34.3–35.3 (107.7–110.8)	35.1–36.0 (110.2–113.2)	35.9–36.8 (112.7–115.7)	36.7–37.6 (115.2–118.2)
	14	35.9–36.9 (112.8–115.8)	36.7–37.6 (115.2–118.2)	37.5–38.4 (117.7–120.7)	38.3–39.2 (120.2–123.2)	39.0–40.0 (122.7–125.7)
	15	38.3–39.2 (120.2–123.3)	39.1–40.0 (122.7–125.7)	39.8–40.8 (125.2–128.2)	40.6–41.6 (127.7–130.7)	41.4–42.4 (130.2–133.2)
	16	40.7–41.6 (127.7–130.8)	41.4–42.4 (130.2–133.2)	42.2–43.2 (132.7–135.7)	43.0–44.0 (135.2–138.2)	43.8–44.8 (137.7–140.7)
	17	43.0–44.0 (135.2–138.2)	43.8–44.8 (137.6–140.7)	44.6–45.6 (140.1–143.2)	45.4–46.4 (142.7–145.7)	46.2–47.2 (145.1–148.2)
	18	45.4–46.4 (142.7–145.7)	46.2–47.2 (145.2–148.2)	47.0–48.0 (147.6–150.7)	47.8–48.8 (150.1–153.2)	48.6–49.6 (152.6–155.7)
	19	47.8–48.8 (150.2–153.2)	48.6–49.6 (152.6–155.7)	49.4–50.4 (155.1–158.2)	50.2–51.2 (157.6–160.7)	51.0–52.0 (160.1–163.2)
	20	50.2–51.2 (157.6–160.7)	51.0–51.9 (160.1–163.2)	51.8–52.7 (162.6–165.7)	52.6–53.5 (165.1–168.2)	53.4–54.3 (167.6–170.7)
	21	52.6–53.6 (165.2–168.2)	53.4–54.3 (167.6–170.7)	54.2–55.1 (170.1–173.2)	54.9–55.9 (172.6–175.7)	55.7–56.7 (175.1–178.2)
	22	54.9–55.9 (172.6–175.7)	55.7–56.7 (175.1–178.2)	56.5–57.5 (177.6–180.7)	57.3–58.3 (180.1–183.2)	58.1–59.1 (182.6–185.7)
	23	57.3–58.3 (180.1–183.2)	58.1–59.1 (182.6–185.7)	58.9–59.9 (185.1–188.2)	59.7–60.7 (187.6–190.7)	60.5–61.5 (190.1–193.2)
	24	59.7–60.7 (187.6–190.7)	60.5–61.5 (190.1–193.2)	61.3–62.3 (192.7–195.7)	62.1–63.1 (195.1–198.2)	62.9–63.9 (197.6–200.7)

- a. The first numbers represent the outside pipe diameter. The numbers between parenthesis represent the pipe circumference.

(continued from facing page)

		Number of short links (Ordering number: ChainScan-A-SLink)				
		5	6	7	8	9
Number of long links (Ordering number: ChainScan-A-LgLink)	0	6.1–7.0 (19.3–22.0)	7.0–7.8 (21.9–24.6)	7.8–8.7 (24.4–27.2)	8.6–9.5 (27.0–29.8)	9.4–10.3 (29.5–32.3)
	1	N/A	9.6–10.5 (30.1–32.9)	10.4–11.2 (32.6–35.3)	11.1–12.0 (35.0–37.8)	11.9–12.8 (37.5–40.3)
	2	11.3–12.2 (35.4–38.2)	12.0–12.9 (37.8–40.6)	12.8–13.7 (40.3–43.1)	13.6–14.5 (42.7–45.5)	14.4–15.3 (45.1–48.0)
	3	13.7–14.6 (43.0–45.8)	14.4–15.3 (45.4–48.2)	15.2–16.1 (47.8–50.7)	16.0–16.9 (50.3–53.1)	16.8–17.7 (52.7–55.6)
	4	16.1–17.0 (50.5–53.3)	16.8–17.8 (52.9–55.8)	17.6–18.5 (55.3–58.2)	18.4–19.3 (57.8–60.7)	19.2–20.1 (60.2–63.2)
	5	18.4–19.4 (57.9–60.8)	19.2–20.1 (60.4–63.3)	20.0–20.9 (62.8–65.7)	20.8–21.7 (65.3–68.2)	21.6–22.5 (67.7–70.7)
	6	20.8–21.7 (65.4–68.3)	21.6–22.5 (67.8–70.8)	22.4–23.3 (70.3–73.3)	23.2–24.1 (72.8–75.7)	23.9–24.9 (75.2–78.2)
	7	23.2–24.1 (72.9–75.8)	24.0–24.9 (75.3–78.3)	24.8–25.7 (77.8–80.7)	25.5–26.5 (80.3–83.2)	26.3–27.3 (82.7–85.7)
	8	25.6–26.5 (80.3–83.3)	26.4–27.3 (82.8–85.8)	27.1–28.1 (85.2–88.2)	27.9–28.9 (87.7–90.7)	28.7–29.7 (90.2–93.2)
	9	27.9–28.9 (87.8–90.8)	28.7–29.7 (90.2–93.3)	29.5–30.5 (92.7–95.7)	30.3–31.3 (95.2–98.2)	31.1–32.1 (97.7–100.7)
	10	30.3–31.3 (95.2–98.3)	31.1–32.1 (97.7–100.8)	31.9–32.9 (100.2–103.2)	32.7–33.6 (102.7–105.7)	33.5–34.4 (105.2–108.2)
	11	32.7–33.7 (102.7–105.7)	33.5–34.5 (105.2–108.2)	34.3–35.2 (107.7–110.7)	35.1–36.0 (110.2–113.2)	35.9–36.8 (112.7–115.7)
	12	35.1–36.0 (110.2–113.2)	35.9–36.8 (112.7–115.7)	36.7–37.6 (115.2–118.2)	37.5–38.4 (117.7–120.7)	38.3–39.2 (120.2–123.2)
	13	37.5–38.4 (117.7–120.7)	38.3–39.2 (120.2–123.2)	39.0–40.0 (122.7–125.7)	39.8–40.8 (125.2–128.2)	40.6–41.6 (127.7–130.7)
	14	39.8–40.8 (125.2–128.2)	40.6–41.6 (127.7–130.7)	41.4–42.4 (130.2–133.2)	42.2–43.2 (132.7–135.7)	43.0–44.0 (135.2–138.2)
	15	42.2–43.2 (132.7–135.7)	43.0–44.0 (135.2–138.2)	43.8–44.8 (137.7–140.7)	44.6–45.6 (140.2–143.2)	45.4–46.4 (142.6–145.7)
	16	44.6–45.6 (140.2–143.2)	45.4–46.4 (142.7–145.7)	46.2–47.2 (145.1–148.2)	47.0–48.0 (147.6–150.7)	47.8–48.8 (150.1–153.2)
	17	47.0–48.0 (147.6–150.7)	47.8–48.8 (150.1–153.2)	48.6–49.6 (152.6–155.7)	49.4–50.4 (155.1–158.2)	50.2–51.2 (157.6–160.7)
	18	49.4–50.4 (155.1–158.2)	50.2–51.2 (157.6–160.7)	51.0–52.0 (160.1–163.2)	51.8–52.7 (162.6–165.7)	52.6–53.5 (165.1–168.2)
	19	51.8–52.7 (162.6–165.7)	52.6–53.5 (165.1–168.2)	53.4–54.3 (167.6–170.7)	54.1–55.1 (170.1–173.2)	55.0–55.9 (172.6–175.7)
	20	54.2–55.1 (170.1–173.2)	54.9–55.9 (172.6–175.7)	55.7–56.7 (175.1–178.2)	56.5–57.5 (177.6–180.7)	57.3–58.3 (180.1–183.2)
	21	56.5–57.5 (177.6–180.7)	57.3–58.3 (180.1–183.2)	58.1–59.1 (182.6–185.7)	58.9–59.9 (185.1–188.2)	59.7–60.7 (187.6–190.7)
	22	58.9–59.9 (185.1–188.2)	59.7–60.7 (187.6–190.7)	60.5–61.5 (190.1–193.2)	61.3–62.3 (192.6–195.7)	62.1–63.1 (195.1–198.2)
	23	61.3–62.3 (192.7–195.7)	62.1–63.1 (195.1–198.2)	62.9–63.9 (197.6–200.7)	63.7–64.7 (200.1–203.2)	64.5–65.5 (202.6–205.8)
24	63.7–64.7 (200.1–203.2)	64.5–65.5 (202.6–205.7)	65.3–66.3 (205.1–208.2)	66.1–67.1 (207.6–210.7)	66.9–67.9 (210.1–213.2)	

Table 9 ChainSCANNER sizing chart (centimeters)

		Number of short links (Ordering number: ChainScan-A-SLink)				
		0	1	2	3	4
Number of long links (Ordering number: ChainScan-A-LgLink)	0	N/A	4.1–8.9 (13.0–28.0 ^a)	8.8–11.2 (27.5–35.3)	11.0–13.5 (34.5–42.3)	13.1–15.6 (41.2–49.1)
	1	N/A	N/A	N/A	N/A	N/A
	2	N/A	N/A	24.5–25.1 (76.8–78.7)	24.8–27.0 (78.1–84.8)	26.7–28.9 (84.0–90.9)
	3	25.3–27.3 (79.3–85.8)	27.1–29.2 (85.3–91.8)	29.0–31.1 (91.1–97.8)	30.9–33.1 (97.0–103.9)	32.8–35.1 (103.1–110.1)
	4	31.2–33.3 (97.9–104.7)	33.0–35.3 (103.8–110.8)	35.0–37.2 (109.8–116.9)	36.9–39.1 (115.9–123.0)	38.8–41.1 (122.0–129.2)
	5	37.1–39.3 (116.5–123.6)	39.0–41.3 (122.5–129.6)	40.9–43.2 (128.6–135.8)	42.9–45.2 (134.8–142.0)	44.9–47.2 (140.9–148.3)
	6	43.0–45.4 (135.2–142.5)	45.0–47.3 (141.3–148.6)	46.9–49.3 (147.4–154.8)	48.9–51.3 (153.7–161.0)	50.9–53.2 (159.9–167.3)
	7	49.0–51.4 (154.0–161.3)	51.0–53.3 (160.1–167.5)	52.9–55.3 (166.3–173.7)	54.9–57.3 (172.5–180.0)	56.9–59.3 (178.8–186.2)
	8	55.0–57.4 (172.9–180.3)	57.0–59.4 (179.0–186.5)	59.0–61.3 (185.2–192.7)	61.0–63.3 (191.5–199.0)	62.9–65.3 (197.8–205.3)
	9	61.0–63.4 (191.7–199.2)	63.0–65.4 (197.8–205.4)	65.0–67.4 (204.1–211.7)	67.0–69.4 (210.4–217.9)	69.0–71.4 (216.7–224.3)
	10	67.0–69.5 (210.6–218.2)	69.0–71.4 (216.8–224.4)	71.0–73.4 (223.1–230.6)	73.0–75.4 (229.4–237.0)	75.0–77.4 (235.6–243.2)
	11	73.1–75.5 (229.6–237.1)	75.0–77.5 (235.7–243.3)	77.0–79.5 (242.0–249.7)	79.0–81.5 (248.3–256.0)	81.0–83.5 (254.6–262.3)
	12	79.1–81.5 (248.5–256.2)	81.1–83.5 (254.7–262.3)	83.1–85.5 (260.9–268.7)	85.1–87.5 (267.3–274.9)	87.1–89.5 (273.6–281.3)
	13	85.1–87.6 (267.5–275.1)	87.1–89.6 (273.6–281.4)	89.1–91.6 (280.0–287.6)	91.1–93.6 (286.3–294.0)	93.1–95.6 (292.6–300.3)
	14	91.2–93.6 (286.4–294.1)	93.2–95.6 (292.7–300.3)	95.1–97.6 (298.9–306.7)	97.2–99.6 (305.3–313.0)	99.2–101.6 (311.6–319.3)
	15	97.2–99.7 (305.4–313.2)	99.2–101.7 (311.6–319.3)	101.2–103.7 (317.9–325.7)	103.2–105.7 (324.3–332.0)	105.2–107.7 (330.6–338.4)
	16	103.3–105.7 (324.4–332.2)	105.2–107.7 (330.6–338.4)	107.3–109.7 (337.0–344.7)	109.3–111.7 (343.3–351.1)	111.3–113.8 (349.7–357.4)
	17	109.3–111.8 (343.4–351.1)	111.3–113.8 (349.6–357.4)	113.3–115.8 (355.9–363.7)	115.3–117.8 (362.3–370.1)	117.4–119.8 (368.7–376.4)
	18	115.4–117.8 (362.4–370.2)	117.4–119.8 (368.7–376.4)	119.3–121.8 (374.9–382.8)	121.4–123.9 (381.4–389.1)	123.4–125.9 (387.7–395.5)
	19	121.4–123.9 (381.5–389.2)	123.4–125.9 (387.7–395.5)	125.4–127.9 (394.1–401.8)	127.4–129.9 (400.4–408.2)	129.5–132.0 (406.7–414.6)
	20	127.5–130.0 (400.4–408.3)	129.5–131.9 (406.7–414.5)	131.5–134.0 (413.1–420.9)	133.5–136.0 (419.4–427.2)	135.5–138.0 (425.8–433.6)
	21	133.5–136.0 (419.5–427.3)	135.5–138.0 (425.8–433.6)	137.5–140.0 (432.1–439.9)	139.6–142.1 (438.4–446.3)	141.6–144.1 (444.8–452.6)
	22	139.6–142.1 (438.5–446.4)	141.6–144.1 (444.7–452.6)	143.6–146.1 (451.1–459.0)	145.6–148.1 (457.5–465.3)	147.6–150.2 (463.8–471.7)
	23	145.6–148.1 (457.6–465.4)	147.6–150.1 (463.7–471.6)	149.7–152.1 (470.2–478.0)	151.7–154.2 (476.5–484.4)	153.7–156.2 (482.8–490.7)
	24	151.7–154.2 (476.6–484.4)	153.7–156.2 (482.9–490.7)	155.8–158.2 (489.3–497.1)	157.7–160.2 (495.5–503.4)	159.7–162.3 (501.9–509.8)

- a. The first numbers represent the outside pipe diameter. The numbers between parenthesis represent the pipe circumference.

(continued from facing page)

		Number of short links (Ordering number: ChainScan-A-SLink)				
		5	6	7	8	9
Number of long links (Ordering number: ChainScan-A-LgLink)	0	15.6–17.8 (49.0–55.9)	17.7–19.9 (55.6–62.5)	19.8–22.0 (62.1–69.1)	21.8–24.1 (68.6–75.6)	23.9–26.1 (75.0–82.1)
	1	N/A	24.4–26.6 (76.5–83.5)	26.3–28.6 (82.7–89.7)	28.3–30.6 (89.0–96.1)	30.3–32.6 (95.1–102.3)
	2	28.7–30.9 (90.0–97.0)	30.6–32.8 (96.1–103.1)	32.6–34.8 (102.3–109.4)	34.5–36.8 (108.5–115.7)	36.5–38.8 (114.7–121.9)
	3	34.7–37.0 (109.1–116.3)	36.7–39.0 (115.3–122.5)	38.7–41.0 (121.5–128.7)	40.6–43.0 (127.7–135.0)	42.6–45.0 (133.9–141.3)
	4	40.8–43.1 (128.1–135.4)	42.8–45.1 (134.3–141.7)	44.7–47.1 (140.6–147.8)	46.7–49.1 (146.8–154.2)	48.7–51.1 (153.0–160.4)
	5	46.8–49.2 (147.1–154.4)	48.8–51.2 (153.4–160.7)	50.8–53.1 (159.6–167.0)	52.8–55.2 (165.8–173.3)	54.8–57.2 (172.1–179.6)
	6	52.9–55.2 (166.1–173.5)	54.8–57.2 (172.3–179.8)	56.8–59.2 (178.6–186.1)	58.8–61.2 (184.8–192.3)	60.8–63.2 (191.1–198.7)
	7	58.9–61.3 (185.1–192.5)	60.9–63.3 (191.3–198.8)	62.9–65.3 (197.6–205.1)	64.9–67.3 (203.8–211.4)	66.9–69.3 (210.1–217.7)
	8	64.9–67.3 (204.0–211.5)	66.9–69.3 (210.3–217.9)	68.9–71.3 (216.5–224.1)	70.9–73.4 (222.9–230.5)	72.9–75.4 (229.1–236.8)
	9	71.0–73.4 (223.0–230.5)	73.0–75.4 (229.2–236.9)	75.0–77.4 (235.6–243.1)	77.0–79.4 (241.8–249.5)	79.0–81.4 (248.2–255.8)
	10	77.0–79.4 (241.9–249.6)	79.0–81.5 (248.2–255.9)	81.0–83.5 (254.6–262.2)	83.0–85.5 (260.8–268.5)	85.0–87.5 (267.2–274.8)
	11	83.1–85.5 (260.9–268.6)	85.1–87.5 (267.3–274.9)	87.1–89.5 (273.5–281.3)	89.1–91.5 (279.9–287.5)	91.1–93.5 (286.2–293.9)
	12	89.1–91.6 (280.0–287.6)	91.1–93.6 (286.2–294.0)	93.1–95.6 (292.6–300.3)	95.1–97.6 (298.9–306.6)	97.2–99.6 (305.2–313.0)
	13	95.1–97.6 (298.9–306.7)	97.2–99.6 (305.3–313.0)	99.2–101.6 (311.6–319.3)	101.2–103.7 (317.9–325.7)	103.2–105.7 (324.3–332.0)
	14	101.2–103.7 (317.9–325.7)	103.2–105.7 (324.3–332.0)	105.2–107.7 (330.6–338.4)	107.3–109.7 (337.0–344.7)	109.3–111.7 (343.3–351.0)
	15	107.3–109.7 (337.0–344.7)	109.3–111.7 (343.3–351.0)	111.3–113.8 (349.6–357.4)	113.3–115.8 (356.0–363.7)	115.3–117.8 (362.3–370.1)
	16	113.3–115.8 (356.0–363.7)	115.3–117.8 (362.3–370.1)	117.4–119.8 (368.7–376.4)	119.4–121.9 (375.0–382.8)	121.4–123.9 (381.3–389.2)
	17	119.4–121.8 (375.0–382.8)	121.4–123.9 (381.4–389.2)	123.4–125.9 (387.7–395.5)	125.4–127.9 (394.0–401.9)	127.4–129.9 (400.4–408.2)
	18	125.4–127.9 (394.0–401.9)	127.4–129.9 (400.4–408.2)	129.5–132.0 (406.7–414.5)	131.5–134.0 (413.1–420.9)	133.5–136.0 (419.4–427.2)
	19	131.5–134.0 (413.1–420.9)	133.5–136.0 (419.4–427.2)	135.5–138.0 (425.8–433.6)	137.5–140.1 (432.1–440.0)	139.6–142.1 (438.5–446.3)
	20	137.5–140.0 (432.1–439.9)	139.6–142.0 (438.4–446.3)	141.6–144.1 (444.8–452.7)	143.6–146.1 (451.2–459.0)	145.6–148.1 (457.5–465.4)
	21	143.6–146.1 (451.1–459.0)	145.6–148.2 (457.5–465.4)	147.7–150.1 (463.9–471.7)	149.7–152.2 (470.2–478.0)	151.7–154.2 (476.6–484.5)
	22	149.7–152.2 (470.2–478.1)	151.7–154.2 (476.5–484.4)	153.7–156.2 (482.9–490.7)	155.7–158.2 (489.3–497.2)	157.8–160.3 (495.6–503.5)
	23	155.8–158.2 (489.4–497.1)	157.8–160.3 (495.6–503.5)	159.8–162.3 (501.9–509.8)	161.8–164.3 (508.3–516.2)	163.8–166.4 (514.6–522.7)
	24	161.8–164.3 (508.3–516.2)	163.8–166.3 (514.6–522.5)	165.8–168.3 (521.0–528.9)	167.8–170.4 (527.3–535.3)	169.9–172.4 (533.7–541.6)

Appendix B: Wedge-Probe Assembly Maintenance

The following procedures are not specific to the ChainSCANNER. They are nevertheless useful information to complete this manual.

B.1 Adjustment of the Carbide Wear-Pins on Wedges

Wedges are designed to hold a transducer or a phased array probe in order to ensure an adequate ultrasonic diffusion through the surface being inspected, and to direct the couplant flow correctly. To limit wear to the wedge, carbide wear-pins can be inserted at each corner of the contact surface of the wedge (see Figure 7-2 on page 90).

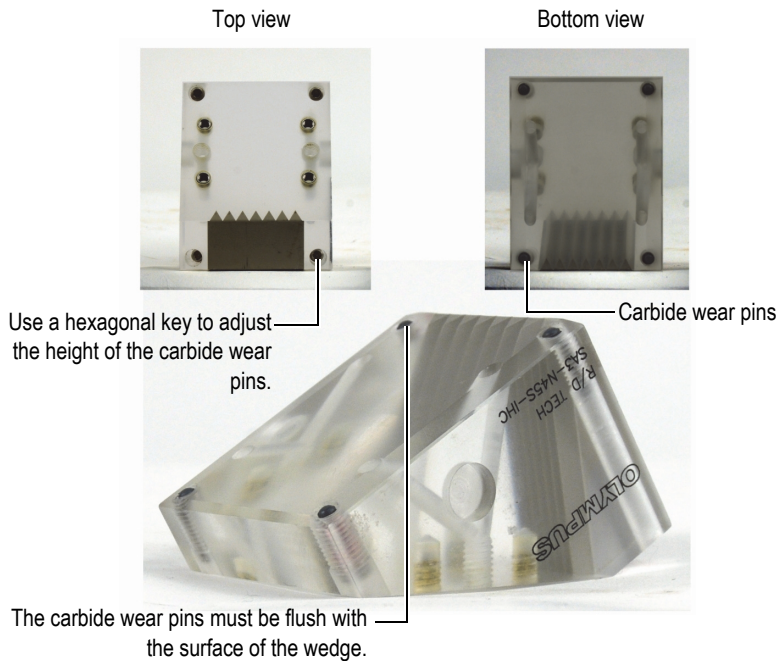

Figure 7-2 Adjusting the wedge's carbide wear pins

To adjust the carbide wear-pins on a wedge

1. Turn off the couplant flow.
2. Use a hexagonal key to adjust the height of the carbide wear pins on each installed wedge. Ensure that the top of each pin is flush to the surface of the wedge (see Figure 7-2 on page 90).

B.2 Replacing a Conventional Ultrasonic Transducer

To replace a conventional ultrasonic transducer, the assembly holding the transducer must be removed and partially disassembled.

To replace a conventional ultrasonic transducer

1. Turn off the couplant flow.
2. Disconnect the couplant tubes from the couplant source, or from the wedge.
3. Remove the scanner from the inspection surface.
4. Disconnect the transducer cable.
5. Lift the swing arm until the latch engages into its higher position (see “To latch the swing arm” on page 40).
6. Use the wing knob to release the probe arm that holds the yoke parts together (see Figure 7-3 on page 93).
7. Ensure that the transducer cable is disconnected, and then unscrew the transducer from the wedge.
It is possible to unscrew the transducer without removing the wedge.
8. Screw the new transducer onto the wedge.

NOTE

Before installing a new transducer on the wedge, ensure that there is a sufficient amount of couplant between the transducer and the wedge.

9. Tighten the transducer on the wedge.
-



CAUTION

Do not overtighten the transducer; overtightening might crack the wedge.

10. Reinstall the wedge in the yoke.
11. Lift the swing arm slightly.
12. Pull out the latch knob.
13. Release the swing arm slowly to its lower position (see “To unlatch the swing arm” on page 40).

B.3 Replacing a Phased Array Probe

To replace a phased array ultrasonic probe, the probe assembly must be removed and partially disassembled.

To replace a phased array probe

1. Turn off the couplant flow.
2. Disconnect the couplant tubes from the couplant source.
3. Disconnect the probe cable from the instrument.



CAUTION

To prevent any damage to the Hypertronics connector pins, be sure to always install the protective cover when the probe cable is disconnected.

4. Remove the scanner from the inspection surface.
5. Lift the swing arm until the latch engages into its higher position (see “To latch the swing arm” on page 40).

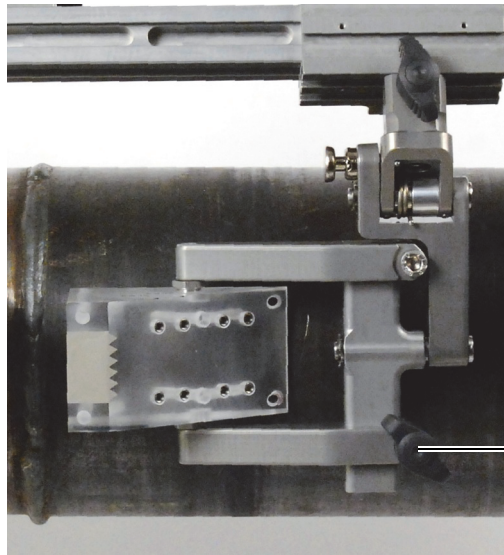

Turn the wing knob *counterclockwise* to free the mobile yoke arm.

Figure 7-3 The wing knob holding the mobile yoke arm

6. Use the wing knob to free the mobile yoke arm that holds the yoke parts together (see Figure 7-3 on page 93).
7. Using a cross-headed screwdriver, unscrew the screws that hold the probe on the wedge (either two or four screws, depending on the model), and then remove the probe.
8. Install the new probe onto the wedge.

NOTE

Before installing a new probe on the wedge, ensure that there is a sufficient amount of couplant between the probe and the wedge.

9. Tighten the screws that hold the probe on the wedge.



CAUTION

Do not overtighten the screws: overtightening might crack the wedge.

10. Reinstall the wedge-probe assembly on the yoke.
11. Lift the swing arm slightly.
12. Pull out the latch knob.
13. Release the swing arm slowly to its lower position (see “To unlatch the swing arm” on page 40).

List of Figures

Figure 1-1	The ChainSCANNER main components	25
Figure 1-2	The slide bar assembly	26
Figure 1-3	The probe displacement system	27
Figure 1-4	The probe-holder assembly parts	28
Figure 1-5	The buckle assembly parts	29
Figure 1-6	The encoder umbilical cable	29
Figure 1-7	The main module components	30
Figure 1-8	The y-axis encoder location	30
Figure 1-9	The short and long links	31
Figure 2-1	Coupling the main module with the slide bar	34
Figure 2-2	Collapsing and opening a split dovetail	35
Figure 2-3	Removing the ergonomic cover	36
Figure 2-4	The main module without the encoder umbilical cable	37
Figure 2-5	The encoder connector and the cable management tabs.	37
Figure 2-6	Pull out and rotate slightly to latch the link knobs to the open position.	39
Figure 2-7	Probe-holder assembly parts	40
Figure 2-8	Collapsing and opening a split dovetail	42
Figure 2-9	Installing a probe holder	42
Figure 2-10	Adjusting the distance between the probes	43
Figure 2-11	The slide bar assembly	44
Figure 2-12	Changing the yoke arms	45
Figure 2-13	Replacing the slide bar and the lead screw	46
Figure 2-14	Installing or removing the y-axis slide assembly	47
Figure 2-15	Installing or removing the y-axis encoder	48
Figure 2-16	Sliding annular part of the relief connector over the cable sheath	49
Figure 2-17	Inserting the threaded portion of the strain relief into the cable sheath ...	49
Figure 2-18	Assembling the strain relief connector	50
Figure 2-19	Connecting the umbilical cable to the ChainSCANNER's main module	50

Figure 2-20	Attaching the umbilical cable to the ChainSCANNER	51
Figure 2-21	The ChainSCANNER with four-probe kit installed	52
Figure 2-22	The optional four-probe kit	53
Figure 2-23	The ChainSCANNER, four-probe configuration	54
Figure 2-24	The optional mouse conversion kit	55
Figure 2-25	The main module equipped with the chain attachment	56
Figure 2-26	Mouse-dedicated dovetail front attachment and parking brake	57
Figure 2-27	Using the supplied universal tool to install the magnetic wheels	57
Figure 2-28	Magnetic wheels to hold the mouse scanner on ferromagnetic surface	58
Figure 2-29	The 20-centimeter bar and lead screw option—mouse scanner	59
Figure 2-30	The 20-centimeter bar and lead-screw option—ChainSCANNER	60
Figure 3-1	Closing the chain around the pipe	62
Figure 3-2	Cables passing underneath the module’s ergonomic cover (model equipped with Four-Probe kit shown)	63
Figure 4-1	Center the inspection area between the probes	65
Figure 6-1	ChainSCANNER frame and chain — exploded view	70
Figure 6-2	ChainSCANNER cart — exploded view	73
Figure 7-1	LEMO connector pinout diagram	81
Figure 7-2	Adjusting the wedge’s carbide wear pins	90
Figure 7-3	The wing knob holding the mobile yoke arm	93

List of Tables

Table 1	ChainSCANNER spare parts — frame and chain	70
Table 2	ChainSCANNER spare parts — cart	74
Table 3	ChainSCANNER optional kits and parts	74
Table 4	General specifications	79
Table 5	Operating environment specifications	80
Table 6	Required encoder cable adaptor	80
Table 7	OmniScan MX2 pinout for the scanner interface LEMO connector	81
Table 8	ChainSCANNER sizing chart (inches)	84
Table 9	ChainSCANNER sizing chart (centimeters)	86

