



# OmniScan X3 and OmniScan X3 64 PA/UT Flaw Detector

User's Manual

DMTA-20102-01EN — Rev. 9  
April 2024

This instruction manual contains essential information on how to use this Evident product safely and effectively. Before using this product, thoroughly review this instruction manual. Use the product as instructed. Keep this instruction manual in a safe, accessible location.

EVIDENT CANADA, INC.  
3415, Rue Pierre-Ardouin Québec (QC) G1P 0B3 Canada

Copyright © 2024 by Evident. All rights reserved. No part of this publication may be reproduced, translated, or distributed without the express written permission of Evident.

This document was prepared with particular attention to usage to ensure the accuracy of the information contained therein, and corresponds to the version of the product manufactured prior to the date appearing on the title page. There could, however, be some differences between the manual and the product if the product was modified thereafter.

The information contained in this document is subject to change without notice.

Part number: DMTA-20102-01EN  
Rev. 9  
April 2024

Printed in Canada

The terms HDMI and HDMI High-Definition Multimedia Interface, and the HDMI Logo are trademarks or registered trademarks of HDMI Licensing Administrator, Inc. in the United States and other countries.

SD Logo is a trademark of SD-3C, LLC.



All brands are trademarks or registered trademarks of their respective owners and third party entities.

---

---

# Table of Contents

---

<b>List of Abbreviations .....</b>	<b>7</b>
<b>Important Information – Please Read Before Use .....</b>	<b>9</b>
Intended Use .....	9
Instruction Manual .....	9
Device Compatibility .....	10
Repair and Modification .....	10
Safety Symbols .....	10
Safety Signal Words .....	11
Note Signal Words .....	12
Safety .....	12
Warnings .....	12
Battery Precautions .....	13
Regulations for Shipping Products with Lithium-Ion Batteries .....	15
Equipment Disposal .....	15
BC (Battery Charger - California, USA Community) .....	15
CE (European Conformity) .....	16
UKCA (United Kingdom) .....	16
RCM (Australia) .....	16
WEEE Directive .....	16
China RoHS .....	17
Korea Communications Commission (KCC) .....	18
EMC Directive Compliance .....	18
FCC (USA) Compliance .....	19
ICES-001 (Canada) Compliance .....	20
Warranty Information .....	20
Technical Support .....	21
<b>Introduction .....</b>	<b>23</b>

<b>1. Package Content .....</b>	<b>25</b>
<b>2. Overview .....</b>	<b>27</b>
2.1 Display Touch Screen .....	28
2.2 Main Controls .....	28
2.3 Power Key .....	29
2.4 Help Key .....	29
2.5 Function Keys .....	29
2.6 Indicator Lights .....	29
2.6.1 Power Indicator Light .....	29
2.6.2 Acquisition Indicator Light .....	30
2.6.3 Alarm Indicator Lights .....	30
2.7 Left Side Panel .....	31
2.8 Right Side Panel .....	33
2.9 Top Panel .....	33
2.10 Rear Panel .....	35
2.11 Harness Anchor Points .....	36
2.12 Special-Purpose Side Door .....	37
<b>3. Basic Operation .....</b>	<b>41</b>
3.1 Turning On and Off the OmniScan X3 .....	41
3.2 Activating the Automatic Start-Up Mode .....	42
3.3 Operating on AC Power .....	43
3.4 Lithium-Ion Battery .....	44
3.4.1 Battery Status Indicators .....	45
3.4.2 Removing and Installing a Battery .....	46
3.4.3 Charging a Battery .....	48
3.4.4 Storing Batteries and Extending Life .....	49
3.4.5 Used Battery Disposal .....	51
3.4.6 Warnings on Battery Use .....	51
3.5 Software .....	52
3.6 Global Positioning System (GPS) .....	52
<b>4. Maintenance and Troubleshooting .....</b>	<b>53</b>
4.1 Preventative Maintenance .....	53
4.2 Instrument Cleaning .....	53
4.2.1 Cleaning the Casing .....	53
4.2.2 Cleaning the Screen and Screen Protector .....	54
4.2.3 Cleaning or Changing the Fan .....	54
4.3 Replacing the Touch-Screen Protector .....	57
4.4 Troubleshooting .....	57

---

<b>5. Specifications</b>	<b>61</b>
5.1 General Specifications	61
5.2 Acquisition Connector Specifications	63
5.2.1 Acoustic Specifications	64
5.2.2 Acquisition Specifications	66
5.2.3 Data Specifications	67
<b>6. Connector References</b>	<b>69</b>
6.1 Scanner Encoder Connector	70
6.2 Alarm and I/O Connector	71
<b>7. Connection to a PC with WeldSight Remote Connect</b>	<b>73</b>
7.1 Launching WeldSight Remote Connect	73
7.2 Connecting the OmniScan X3 to WeldSight	77
<b>Appendix: Accessories and Spare Parts</b>	<b>81</b>
<b>List of Figures</b>	<b>85</b>
<b>List of Tables</b>	<b>87</b>



---

## List of Abbreviations

---

AC	alternating current
AIM	Acoustic Influence Map
CLK	clock
DC	direct current
DIR	direction
EFUP	environment-friendly use period
FMC	Full Matrix Capture
GPS	Global Positioning System
I/O	input/output
LAN	local area network
LCD	liquid crystal display
P/N	part number
PA	phased array
RH	relative humidity
SDHC	Secure Digital High Capacity
TCG	time-corrected gain
TFM	Total Focusing Method
TFT	thin film transistor
TOFD	time-of-flight diffraction
TTL	transistor-transistor logic
UT	ultrasonic testing
WEEE	Waste Electrical and Electronic Equipment
WLAN	wireless local area network





---

## Important Information — Please Read Before Use

---

### Intended Use

The OmniScan X3 is designed to perform nondestructive inspections on industrial and commercial materials.



#### **WARNING**

Do not use the OmniScan X3 for any purpose other than its intended use. It must never be used to inspect or examine human or animal body parts.

---

### Instruction Manual

This instruction manual contains essential information on how to use this product safely and effectively. Before using this product, thoroughly review this instruction manual. Use the product as instructed. Keep this instruction manual in a safe, accessible location.

---

#### **IMPORTANT**

Some of the details of components illustrated in this manual may differ from the components installed on your device. However, the operating principles remain the same.

---

## Device Compatibility

Only use this device with the approved ancillary equipment provided by Evident. Equipment provided by Evident and approved for use with this device is described later in this manual.

---



### CAUTION

Always use equipment and accessories that meet Evident specifications. Using incompatible equipment could cause equipment malfunction and/or damage, or human injury.

---

## Repair and Modification

This device does not contain any user-serviceable parts. Opening the device might void the warranty.

---



### CAUTION

In order to prevent human injury and/or equipment damage, do not disassemble, modify, or attempt to repair the device.

---

## Safety Symbols

The following safety symbols might appear on the device and in the instruction manual:



General warning symbol

This symbol is used to alert the user to potential hazards. All safety messages that follow this symbol shall be obeyed to avoid possible harm or material damage.

---



High voltage warning symbol

This symbol is used to alert the user to potential electric shock hazards greater than 1000 volts. All safety messages that follow this symbol shall be obeyed to avoid possible harm.

## Safety Signal Words

The following safety signal words might appear in the documentation of the device:



**DANGER**

The DANGER signal word indicates an imminently hazardous situation. It calls attention to a procedure, practice, or the like, which, if not correctly performed or adhered to, will result in death or serious personal injury. Do not proceed beyond a DANGER signal word until the indicated conditions are fully understood and met.



**WARNING**

The WARNING signal word indicates a potentially hazardous situation. It calls attention to a procedure, practice, or the like, which, if not correctly performed or adhered to, could result in death or serious personal injury. Do not proceed beyond a WARNING signal word until the indicated conditions are fully understood and met.



**CAUTION**

The CAUTION signal word indicates a potentially hazardous situation. It calls attention to an operating procedure, practice, or the like, which, if not correctly performed or adhered to, may result in minor or moderate personal injury, material damage, particularly to the product, destruction of part or all of the product, or loss of data. Do not proceed beyond a CAUTION signal word until the indicated conditions are fully understood and met.

## Note Signal Words

The following note signal words could appear in the documentation of the device:

**IMPORTANT**

The IMPORTANT signal word calls attention to a note that provides important information, or information essential to the completion of a task.

**NOTE**

The NOTE signal word calls attention to an operating procedure, practice, or the like, which requires special attention. A note also denotes related parenthetical information that is useful, but not imperative.

**TIP**

The TIP signal word calls attention to a type of note that helps you apply the techniques and procedures described in the manual to your specific needs, or provides hints on how to effectively use the capabilities of the product.

## Safety

Before turning on the device, verify that the correct safety precautions have been taken (see the following warnings). In addition, note the external markings on the device, which are described under “Safety Symbols.”

## Warnings



**WARNING**

### General Warnings

- Carefully read the instructions contained in this instruction manual prior to turning on the device.
- Keep this instruction manual in a safe place for further reference.

- Follow the installation and operation procedures.
- It is imperative to respect the safety warnings on the device and in this instruction manual.
- If the equipment is used in a manner not specified by the manufacturer, the protection provided by the equipment could be impaired.
- Do not install substitute parts or perform any unauthorized modification to the device.
- Service instructions, when applicable, are for trained service personnel. To avoid the risk of electric shock, do not perform any work on the device unless qualified to do so. For any problem or question regarding this device, contact Evident or an authorized Evident representative.
- Do not touch the connectors directly by hand. Otherwise, a malfunction or electric shock may result.
- Do not allow metallic or foreign objects to enter the device through connectors or any other openings. Otherwise, a malfunction or electric shock may result.

**WARNING****Electrical Warning**

The device must only be connected to a power source corresponding to the type indicated on the rating label.

**CAUTION**

If a non-approved power supply cord not dedicated to Evident products is used, Evident will not be able to ensure the electrical safety of the equipment.

**Battery Precautions****CAUTION**

- Before disposing of a battery, check your local laws, rules, and regulations, and follow them accordingly.

- Transportation of lithium-ion batteries is regulated by the United Nations under the United Nations Recommendations on the Transport of Dangerous Goods. It is expected that governments, intergovernmental organizations, and other international organizations shall conform to the principles laid down in these regulations, thus contributing to worldwide harmonization in this field. These international organizations include the International Civil Aviation organization (ICAO), the International Air Transport Association (IATA), the International Maritime Organization (IMO), the US Department of Transportation (USDOT), Transport Canada (TC), and others. Please contact the transporter and confirm current regulations before transportation of lithium-ion batteries.
- For California (USA) only:  
The device may contain a CR battery. The CR battery contains perchlorate material, and special handling may be required. Refer to <http://www.dtsc.ca.gov/hazardouswaste/perchlorate>.
- Do not open, crush, or perforate batteries; doing so could cause injury.
- Do not incinerate batteries. Keep batteries away from fire and other sources of extreme heat. Exposing batteries to extreme heat (over 80°C) could result in an explosion or personal injury.
- Do not drop, hit, or otherwise abuse a battery, as doing so could expose the cell contents, which are corrosive and explosive.
- Do not short-circuit the battery terminals. A short circuit could cause injury and severe damage to a battery making it unusable.
- Do not expose a battery to moisture or rain; doing so could cause an electric shock.
- Only use an external charger approved by Evident to charge the batteries.
- Only use batteries supplied by Evident.
- Do not store batteries that have less than 40% remaining charge. Recharge batteries to between 40% and 80% capacity before storing them.
- During storage, keep the battery charge between 40% and 80%.
- Do not leave batteries in the OmniScan X3 unit during device storage.

---

## Regulations for Shipping Products with Lithium-Ion Batteries

---

**IMPORTANT**

When shipping a Li-ion battery or batteries, be sure to follow all local transportation regulations.

---



**WARNING**

Damaged batteries cannot be shipped through normal routes — DO NOT ship damaged batteries to Evident. Contact your local Evident representative or material disposal professionals.

---

## Equipment Disposal

Before disposing of the OmniScan X3, check your local laws, rules, and regulations, and follow them accordingly.

## BC (Battery Charger - California, USA Community)



The BC marking indicates that this product has been tested and complies with the Appliance Efficiency Regulations as stated in the California Code of Regulations Title 20, Sections 1601 through 1608 for Battery Charger Systems. The internal battery charger within this device has been tested and certified pursuant to the California Energy Commission's (CEC) requirements; this device is listed on the online CEC's (T20) database.

## CE (European Conformity)



This device complies with the requirements of directive 2014/30/EU concerning electromagnetic compatibility, directive 2014/35/EU concerning low voltage, and directive 2015/863 which amends 2011/65/EU concerning restriction of hazardous substances (RoHS). The CE marking is a declaration that this product conforms to all the applicable directives of the European Community.

## UKCA (United Kingdom)



This device complies with the requirements of the Electromagnetic Compatibility Regulations 2016, the Electrical Equipment (Safety) Regulations 2016, and the Restriction of the Use of Certain Hazardous Substances in Electrical and Electronic Equipment Regulations 2012. The UKCA marking indicates compliance with the above regulations.

## RCM (Australia)



The regulatory compliance mark (RCM) label indicates that the product complies with all applicable standards, and has been registered with the Australian Communications and Media Authority (ACMA) for placement on the Australian market.

## WEEE Directive



In accordance with European Directive 2012/19/EU on Waste Electrical and Electronic Equipment (WEEE), this symbol indicates that the product must not be disposed of as unsorted municipal waste, but should be collected separately. Refer to your local Evident distributor for return and/or collection systems available in your country.





## China RoHS

*China RoHS* is the term used by industry generally to describe legislation implemented by the Ministry of Information Industry (MII) in the People's Republic of China for the control of pollution by electronic information products (EIP).



The China RoHS mark indicates the product's Environment-Friendly Use Period (EFUP). The EFUP is defined as the number of years for which listed controlled substances will not leak or chemically deteriorate while in the product. The EFUP for the OmniScan X3 has been determined to be 15 years.

**Note:** The Environment-Friendly Use Period (EFUP) is not meant to be interpreted as the period assuring functionality and product performance.



电器电子产品有害  
物质限制使用  
标志

本标志是根据“电器电子产品有害物质限制使用管理办法”以及“电子电气产品有害物质限制使用标识要求”的规定，适用于在中国销售的电器电子产品上的电器电子产品有害物质使用限制标志。

（注意）电器电子产品有害物质限制使用标志内的数字为在正常的使用条件下有害物质等不泄漏的期限，不是保证产品功能性能的期间。

产品中有害物质的名称及含量

部件名称		有害物质					
		铅及其化合物 (Pb)	汞及其化合物 (Hg)	镉及其化合物 (Cd)	六价铬及其化合物 (Cr(VI))	多溴联苯 (PBB)	多溴二苯醚 (PBDE)
主体	机构部件	×	○	○	○	○	○
	光学部件	×	○	○	○	○	○
	电气部件	×	○	○	○	○	○

产品中有害物质的名称及含量

部件名称	有害物质					
	铅及其化合物 (Pb)	汞及其化合物 (Hg)	镉及其化合物 (Cd)	六价铬及其化合物 (Cr(VI))	多溴联苯 (PBB)	多溴二苯醚 (PBDE)
附件	×	○	○	○	○	○
<p>本表格依据 SJ/T 11364 的规定编制。</p> <p>○：表示该有害物质在该部件所有均质材料中的含量均在 GB/T26572 规定的限量要求以下。</p> <p>×：表示该有害物质至少在该部件的某一均质材料中的含量超出 GB/T26572 规定的限量要求。</p>						

## Korea Communications Commission (KCC)



Seller and user shall be noticed that this equipment is suitable for electromagnetic equipment for office work (class A) and it can be used outside the home. This device complies with the EMC requirements of Korea.

The MSIP code for the OmniScan X3 is the following:

MSIP-R-R-OYN-OMNIX3.

The MSIP code for the OmniScan X3 64 is the following: MSIP-R-R-OYN-OMNISCANX3-64.

이 기기는 업무용 환경에서 사용할 목적으로 적합성평가를 받은 기기로서 가정용 환경에서 사용하는 경우 전파간섭의 우려가 있습니다.

## EMC Directive Compliance

This equipment generates and uses radio-frequency energy and, if not installed and used properly (that is, in strict accordance with the manufacturer's instructions), may cause interference. The OmniScan X3 has been tested and found to comply with the limits for an industrial device in accordance with the specifications of the EMC directive.

---

## FCC (USA) Compliance

---

<b>NOTE</b>
-------------

This product has been tested and found to comply with the limits for a Class A digital device, pursuant to Part 15 of the FCC Rules. These limits are designed to provide reasonable protection against harmful interference when the product is operated in a commercial environment. This product generates, uses, and can radiate radio frequency energy, and if not installed and used in accordance with the instruction manual, might cause harmful interference to radio communications. Operation of this product in a residential area is likely to cause harmful interference, in which case you will be required to correct the interference at your own expense.

---

---

<b>IMPORTANT</b>
------------------

Changes or modifications not expressly approved by the party responsible for compliance could void the user's authority to operate the product.

---

### FCC Supplier's Declaration of Conformity

Hereby declares that the product,

Product name: OmniScan X3

Model: OmniScan X3-MR/OmniScan X3-CW

Conforms to the following specifications:

FCC Part 15, Subpart B, Section 15.107 and Section 15.109.

Supplementary information:

This device complies with Part 15 of the FCC Rules. Operation is subject to the following two conditions:

- (1) This device may not cause harmful interference.
- (2) This device must accept any interference received, including interference that may cause undesired operation.

Responsible party name:

EVIDENT SCIENTIFIC, INC.

Address:

48 Woerd Avenue, Waltham, MA 02453, USA

Phone number:

+1 781-419-3900

## ICES-001 (Canada) Compliance

This Class A digital apparatus complies with Canadian ICES-001.

Cet appareil numérique de la classe A est conforme à la norme NMB-001 du Canada.

## Warranty Information

Evident guarantees your Evident product to be free from defects in materials and workmanship for a specific period, and in accordance with conditions specified in the *Evident Terms and Conditions* available at <https://evidentscientific.com/evident-terms/>.

The Evident warranty only covers equipment that has been used in a proper manner, as described in this instruction manual, and that has not been subjected to excessive abuse, attempted unauthorized repair, or modification.

Inspect materials thoroughly on receipt for evidence of external or internal damage that might have occurred during shipment. Immediately notify the carrier making the delivery of any damage, because the carrier is normally liable for damage during shipment. Retain packing materials, waybills, and other shipping documentation needed in order to file a damage claim. After notifying the carrier, contact Evident for assistance with the damage claim and equipment replacement, if necessary.

This instruction manual explains the proper operation of your Evident product. The information contained herein is intended solely as a teaching aid, and shall not be used in any particular application without independent testing and/or verification by the operator or the supervisor. Such independent verification of procedures becomes increasingly important as the criticality of the application increases. For this reason, Evident makes no warranty, expressed or implied, that the techniques, examples, or procedures described herein are consistent with industry standards, nor that they meet the requirements of any particular application.

Evident reserves the right to modify any product without incurring the responsibility for modifying previously manufactured products.

## Technical Support

Evident is firmly committed to providing the highest level of customer service and product support. If you experience any difficulties when using our product, or if it fails to operate as described in the documentation, first consult the user's manual, and then, if you are still in need of assistance, contact our After-Sales Service. To locate the nearest service center, visit the *Service Centers* page on the Evident Scientific Web site <https://www.evidentscientific.com/service-and-support/service-centers/>.



---

# Introduction

---

Evident is a long-standing leader in NDT test platforms, with thousands of its inspection instruments in use throughout the world. The OmniScan X3 phased array flaw detector offers technical advancements to further enhance inspection capabilities in many specialized applications.

The OmniScan X3 and OmniScan X3 64 phased array flaw detector hereinafter called OmniScan X3 unless otherwise specified.

---

**NOTE**

Refer to the *OmniScan MXU Software User's Manual* for information on software functions.

---

---

**NOTE**

The illustrations used in this manual were prepared with the instrument version available at the time of publication, and may differ slightly in appearance from the version of the OmniScan X3 that you are using.

---





---

# 1. Package Content

---

The OmniScan X3 package includes the following items:

- OmniScan X3 flaw detector
- Transport case
- Li-ion battery (1)
- Screen protector (1)
- DC power adaptor
- Power cord (model varies according to country)
- Empty USB key for file transfer purposes
- Wireless LAN dongle (model varies according to country)
- USB key loaded with latest OmniPC 5.x software revision and user's manuals.  
Includes:
  - Instrument software
  - *OmniScan X3 and OmniScan X3 64 Getting Started Guide*
  - *OmniScan X3 and OmniScan X3 64 User's Manual*
  - *OmniScan MXU Software User's Manual*

---

<b>NOTE</b>
-------------

For examples of typical accessories with part numbers, see “Accessories and Spare Parts” on page 81.

---



## 2. Overview

The front panel of the OmniScan X3 flaw detector contains the main controls, keys, and indicators (see Figure 2-1 on page 27).

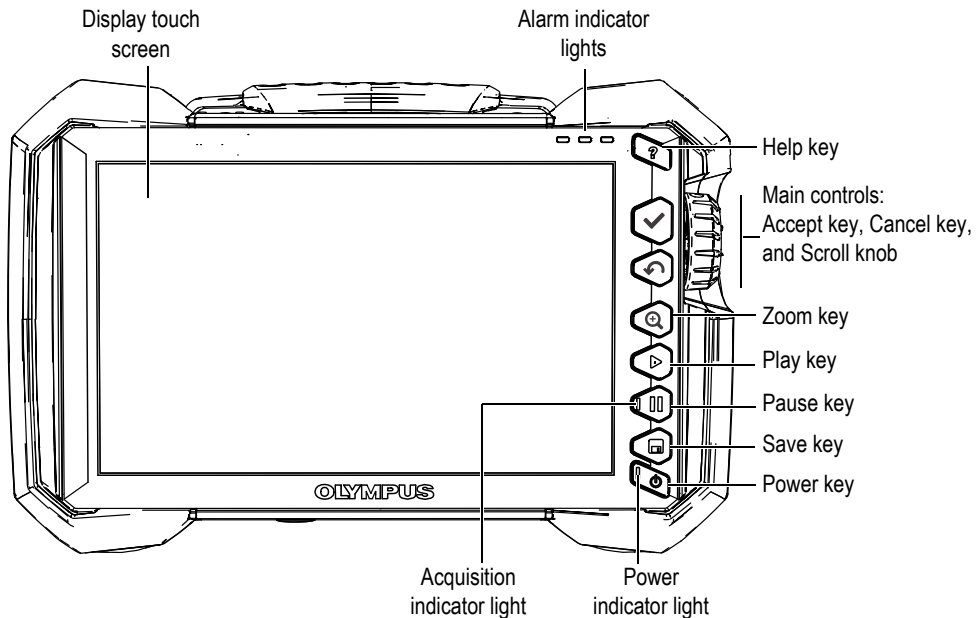

**Figure 2-1 Front panel controls of the OmniScan X3**



## 2.1 Display Touch Screen

The display touch screen acts as a pointing device. To select an interface element, touch the screen surface lightly with your finger. Refer to the *OmniScan MXU Software User's Manual* for advanced operating instructions for the touch screen.

## 2.2 Main Controls

The three main controls shown in see Table 1 on page 28 enable full operation of the OmniScan MXU software.

**Table 1 Main controls for OmniScan X3 flaw detector**

Image	Name	Description
	Scroll knob	Rotate the Scroll knob clockwise or counterclockwise to select a desired software button or change a parameter value.
	Accept key	Press the Accept key to activate the current selection and move on to the next level in the menu hierarchy.  In an alphanumeric parameter value field, pressing the Accept key twice (or tapping the parameter twice) opens the software keyboard.
	Cancel key	Press the Cancel key to cancel the current selection and move back to the previous level in the menu hierarchy.





## 2.3 Power Key

The Power key () is used to start or shut down the OmniScan X3 flaw detector. The indicator light on the key provides power status information (see “Power Indicator Light” on page 29).

## 2.4 Help Key

The Help key () is located on the upper-right side of the OmniScan X3 front panel. This key is intended to display help information, if available, for the currently selected function.

## 2.5 Function Keys

The Zoom () , Play () , Pause () , and Save () keys are used to activate specific functions in the software. For details, refer to the *OmniScan MXU Software User's Manual*.

## 2.6 Indicator Lights

There are three types of indicator lights on the OmniScan X3 front panel: power, acquisition, and alarm. Each indicator light is described below.

### 2.6.1 Power Indicator Light

The power indicator light is located on the Power key () . The color of this light identifies the power status of the OmniScan X3 (see Table 2 on page 29).

**Table 2 Power indicator light statuses**

Indicator light	Status
Off	The OmniScan X3 is turned off.
Flashing orange	The OmniScan X3 is turned off. The battery is charging.

**Table 2 Power indicator light statuses (continued)**

Indicator light	Status
Orange	The OmniScan X3 is turned off. The battery charging is complete.
Green	<ul style="list-style-type: none"> <li>The OmniScan X3 is turned on.</li> <li>The OmniScan X3 is turned on and the battery is charging.</li> </ul>
Flashing red	A critical factor (excessive temperature, very weak battery, etc.) requires immediate attention.

## 2.6.2 Acquisition Indicator Light

The acquisition indicator light is located on the Pause key (). The color of this light indicates the operating mode of the OmniScan X3 flaw detector (see Table 3 on page 30).

**Table 3 Acquisition indicator light statuses**

Off	Inspection mode
Orange	Analysis mode

## 2.6.3 Alarm Indicator Lights

There are three alarm indicator lights located on the upper-right corner of the OmniScan X3. These lights only flash one color (red) and indicate the trigger status of their respective alarms (set within the software).

---

<b>NOTE</b>
-------------

For more details about how to set the alarms that can trigger the alarm indicator lights, refer to the *OmniScan MXU Software User's Manual*.

---

## 2.7 Left Side Panel

The left side panel of the OmniScan X3 flaw detector (Figure 2-2 on page 31) has a door that provides access to the batteries, memory card, and various input and output ports.

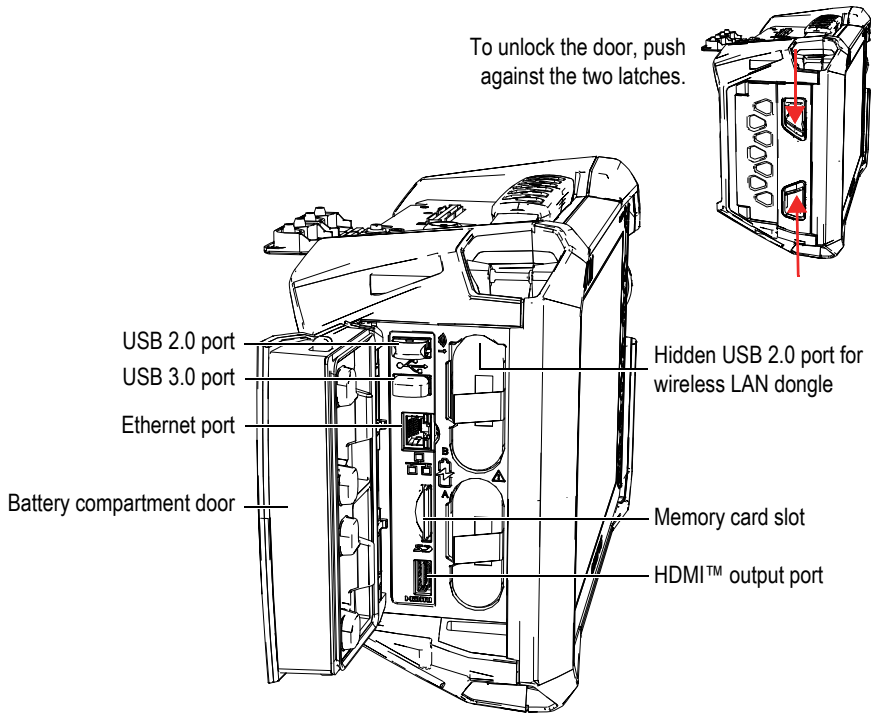

**Figure 2-2 Left side panel of the OmniScan X3**

### Battery compartment door

This door provides access to the battery compartment. Battery replacement is covered in “Removing and Installing a Battery” on page 46.

### HDMI output

The OmniScan X3 flaw detector incorporates HDMI connectivity. An external monitor that mirrors the OmniScan X3 display may be connected to the HDMI port.

### Memory card slot

Slot for inserting a Secure Digital High Capacity (SDHC) memory card.

### USB ports

The USB 2.0 and USB 3.0 ports accommodate USB peripherals such as external storage devices or printers.

---

<b>NOTE</b>
-------------

For compatibility, SDHC cards and USB storage must be formatted to FAT32 or NTFS file systems.

---

### Ethernet port

Used to connect the OmniScan X3 to an Ethernet network.

### Hidden USB 2.0 port—for wireless LAN dongle

Used to connect a dongle for accessing a wireless local area network (WLAN). The wireless LAN dongle is part of the standard inclusions of the OmniScan X3 package. To access the port, remove the top battery, then push against the cover at the top of the interior of the battery compartment, and pull it out (see Figure 2-3 on page 32).



**Figure 2-3** Push the cover (*left*) and pull out the hidden USB 2.0 port (*right*)



## 2.8 Right Side Panel

The right side panel of the OmniScan X3 flaw detector (Figure 2-4 on page 33) contains the DC power adaptor plug, which is protected by a flexible cap. The plug is used to connect an external DC power adaptor to the OmniScan X3.

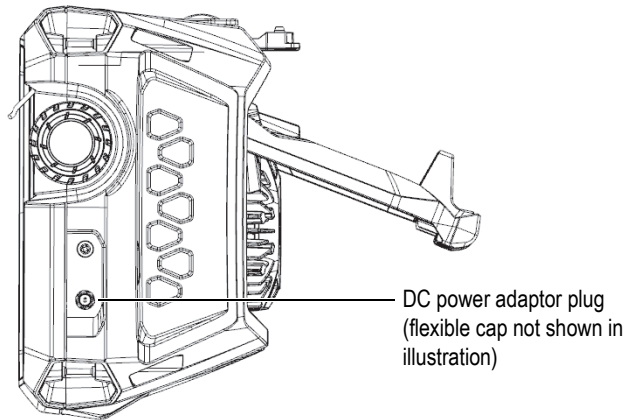

Figure 2-4 Right side panel of the OmniScan X3

## 2.9 Top Panel



### CAUTION



- To reduce the risk of electric shock, avoid touching the inner conductor of the probe connectors. Up to 350 V can be present on the inner conductor of the UT connectors, and up to 120 V can be present on the PA connector. The warning symbol near the PA and UT connectors signals this electric shock risk.
- Reinforced insulation must be provided for the probes connected to the OmniScan X3 flaw detector.



## CAUTION

To avoid the risk of equipment malfunction or damage, use only compatible Evident probes.

The top panel of the OmniScan X3 contains several types of connectors, as shown in Figure 2-5 on page 34.

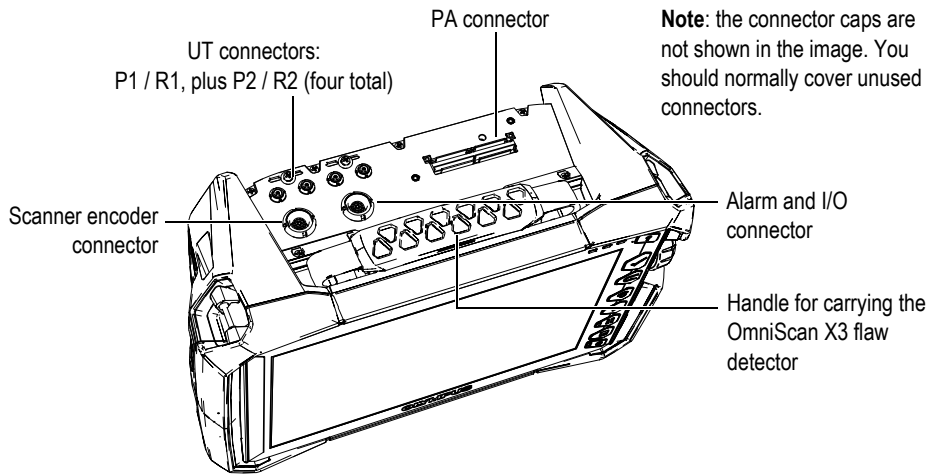

Figure 2-5 Top panel of the OmniScan X3

UT transmission and reception connector: P1 and P2

LEMO connector used for the transmission of ultrasonic signals when using the pitch-catch inspection technique. When in pulse/echo P1 and P2 are used to transmit and receive ultrasonic signals.

UT reception connector: R1 and R2

LEMO connector used for the reception of ultrasonic signals when using the pitch-catch inspection technique.

Alarm and I/O connector

LEMO connector used to connect an external alarm or transmit input and output signals for other external devices.

### Scanner encoder connector

LEMO connector used to connect a scanner equipped with an encoder or transmit input and output signals for other external devices.

### PA connector

Used to connect a phased array probe and probe splitter or adaptor.

Figure 2-6 on page 35 shows the connectors that are compatible with those listed above.

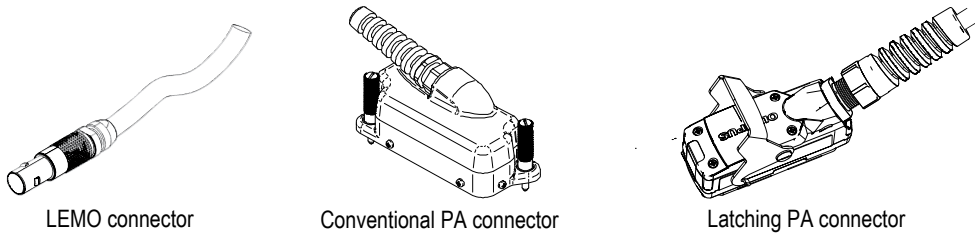

**Figure 2-6 LEMO and phased array probe connectors**

## 2.10 Rear Panel

The rear panel incorporates the heat sink with cooling fan and the support stand (see Figure 2-7 on page 36).



### CAUTION

To avoid the risk of equipment malfunction or damage from overheating, never obstruct the free movement of air in the area around the heat sink and cooling fan. Do not cover the rear of the OmniScan X3 flaw detector with any object or place it against a surface, which could reduce the movement of air over the heat sink or block the cooling fan.

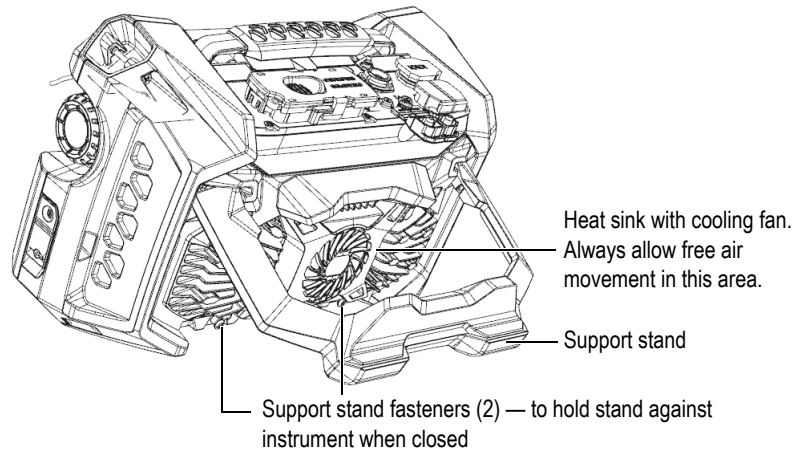

**Figure 2-7 Rear panel of the OmniScan X3**



**CAUTION**

- To prevent the OmniScan X3 from falling over when propped up on a desktop or similar flat surface, you must make sure the support stand is opened to the middle detent position.
  - Do not use the support stand as a handle. Using the support stand as a handle could cause equipment damage or human injury.
- 

## 2.11 Harness Anchor Points

The OmniScan X3 flaw detector has four anchor points for attaching a harness used to carry it (see Figure 2-8 on page 37).

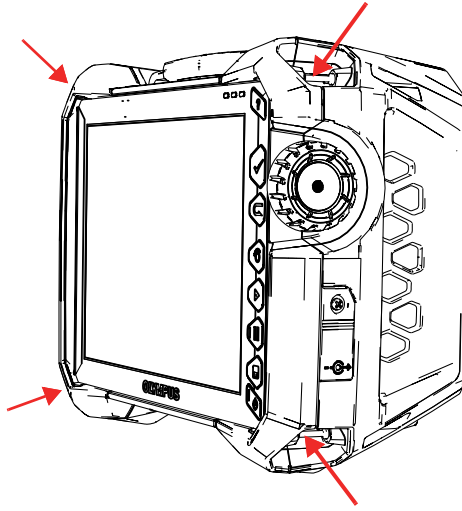

**Figure 2-8 Four anchor points for a harness**

## 2.12 Special-Purpose Side Door

With the special-purpose side door, you can use cables when the door is closed and the OmniScan X3 connected to WeldSight (WeldSight Remote Connect). You can also connect a USB drive (a 30 cm USB extension is included in the door kit).

---

**NOTE**

The IP65 certification does not apply when using the special-purpose door.

---

---

**NOTE**

The special-purpose door offers reasonable protection from objects entering the OmniScan X3 but offers only minimal protection from rain or water. To use the OmniScan X3 into wet or extreme conditions, Evident recommends using the standard (sealed) door that is included with each OmniScan X3.

---

## Assembling the optional special-purpose door

To assemble the optional special-purpose door, you will need a Phillips screwdriver.

### To assemble the door

1. Open the compartment door on the left side panel of the OmniScan X3 and, using a Phillips screwdriver, unscrew the four screws and remove the compartment door (see Figure 2-9 on page 38).

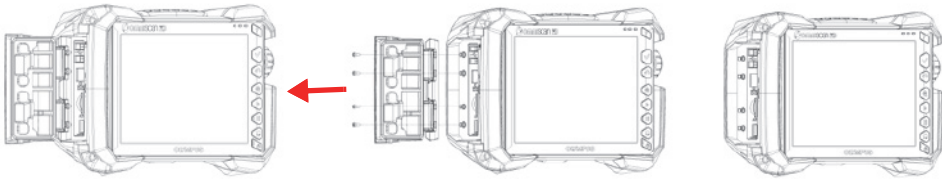

**Figure 2-9** Removing the compartment door

2. Connect the Ethernet, USB and/or HDMI extension cable into the appropriate port (see Figure 2-10 on page 38).

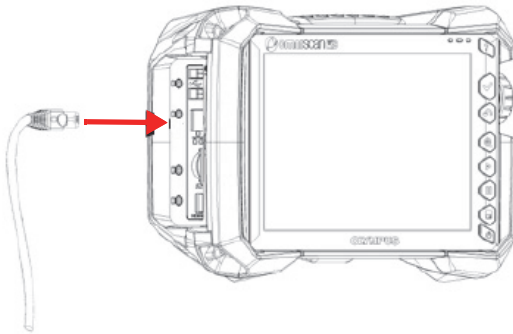

**Figure 2-10** Inserting a cable into its port

3. Make sure the cables are aligned in the slot of the special-purpose door, and slide the door down (see Figure 2-11 on page 39).

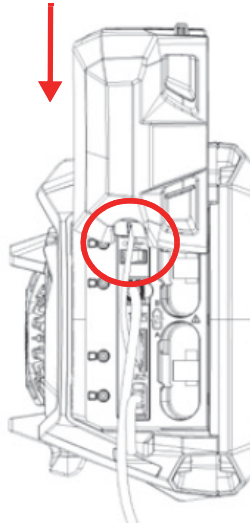

**Figure 2-11 Sliding the door over the aligned cables**

4. Lock the special-purpose door safely in place (see Figure 2-12 on page 40).

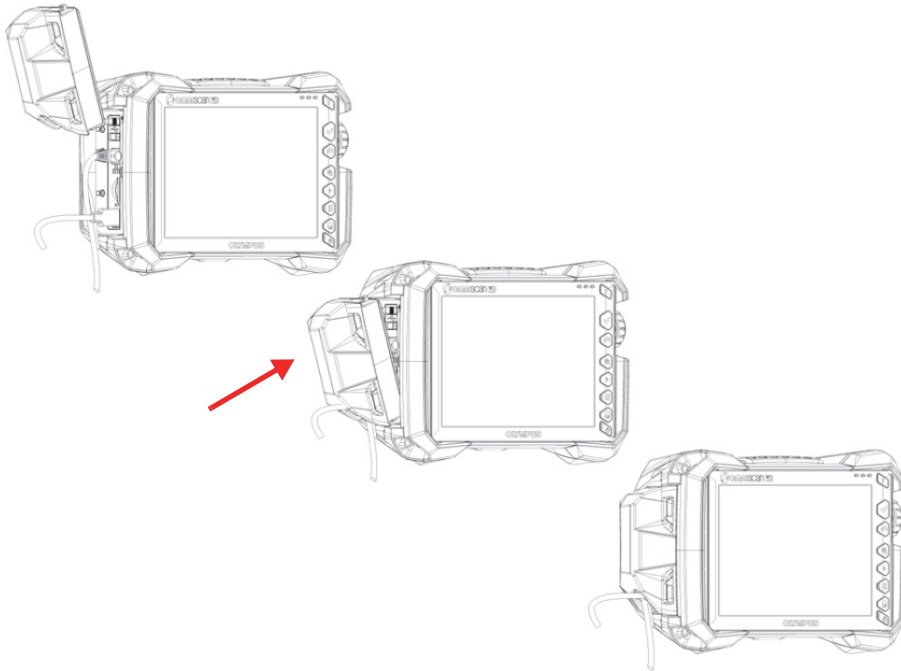

**Figure 2-12 Locking the special-purpose door in place**



---

## 3. Basic Operation

---

This chapter describes the basic principles and procedures involved in operating the OmniScan X3 flaw detector.

### 3.1 Turning On and Off the OmniScan X3

This section explains how to turn on and off the OmniScan X3 flaw detector. The OmniScan MXU software shuts down automatically when you turn off the OmniScan X3 flaw detector.

#### To turn on the OmniScan X3

1. Press and hold the Power key () for one second.

The system starts up, performs a memory check, and the launch screen appears.

---

<b>NOTE</b>
-------------

If the system encounters a problem during the start-up phase, the power indicator light will indicate the nature of the problem using a color code (for details, see “Power Indicator Light” on page 29).

---

2. Tap to start the desired application and/or, if applicable, configure connections such as a removable drive, wireless, or cloud.

#### To turn off the OmniScan X3

1. Quickly press the Power key ()
-

2. Tap the **Shut Down** button on the confirmation window to turn off the OmniScan X3 flaw detector.

---

### IMPORTANT

If the OmniScan X3 does not react after a short press of the Power key (or after selecting **Shut Down**), press and hold the Power key for at least five seconds. This initiates a power-down sequence. However, your setup will NOT be saved with this method.

---



### CAUTION

Never attempt to turn off the OmniScan X3 by removing all power sources, because this could cause a faulty start-up the next time you turn it on.

---

## 3.2 Activating the Automatic Start-Up Mode

The OmniScan X3 flaw detector has an automatic start-up mode, which is also referred to as autoboot mode. Use the autoboot mode to remotely start the OmniScan X3 unit. When this mode is enabled, you do not need to press the Power key () to start the OmniScan X3. The OmniScan X3 starts up automatically when connected to the DC power adaptor. This mode is disabled by default.

### To activate the automatic start-up mode

1. Turn off the OmniScan X3 flaw detector, remove the batteries, and then disconnect the DC power adaptor.
2. Press and hold the Power key ()
3. Connect the OmniScan X3 to the DC power adaptor.
4. Wait for the power indicator light to blink two times, and then release the Power key.
5. To deactivate the autoboot mode, repeat steps 1 to 4.

### 3.3 Operating on AC Power

You can operate the OmniScan X3 flaw detector on AC power using the DC power adaptor (P/N: OMNI-A-AC [U8767093]). The OMNI-A-AC has a universal AC power input, which operates with any line voltage from 100 VAC to 120 VAC or from 200 VAC to 240 VAC, and at 50 Hz to 60 Hz line frequency.



#### WARNING

To avoid the risk of injury or equipment damage, only use the DC power adaptor indoors.

---

#### To operate on AC power

1. Connect the AC power cord to the DC power adaptor (P/N: OMNI-A-AC [U8767093]) and to an appropriate power outlet.
- 



#### CAUTION

- To avoid the risk of human injury or equipment damage, use only the AC power cord supplied with the OmniScan X3. Do not use this AC power cord with other products.
  - The OmniScan X3 must only be connected to a power source corresponding to the type indicated on the rating label. Therefore, use only the DC power adaptor that is delivered with the OmniScan X3.
- 
2. On the right-hand side of the OmniScan X3, lift the flexible rubber cap to expose the DC power adaptor plug (see Figure 3-1 on page 44).

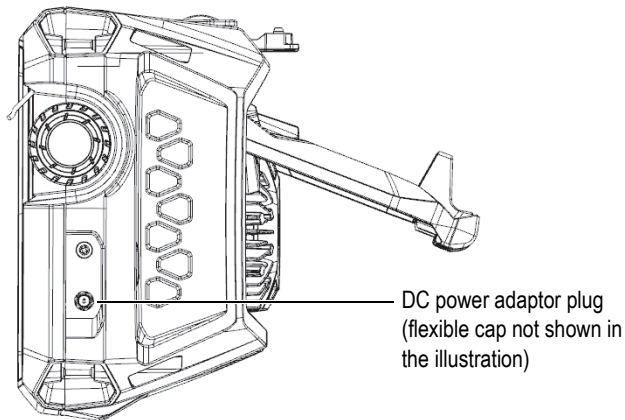

**Figure 3-1 DC power adaptor plug**

3. Connect the DC power adaptor to the plug on the OmniScan X3.
4. Press the Power key (  ) to start the OmniScan X3.

### 3.4 Lithium-Ion Battery

The OmniScan X3 flaw detector holds two lithium-ion batteries (P/N: OMNI-A-BATT [U8760010]). The lithium-ion batteries can be inserted and removed without shutting down the OmniScan X3, as long as it remains connected to another valid power source (DC power adaptor).

The OmniScan X3 also includes a lithium coin battery that does not need to be removed or replaced by the user. The coin battery maintains the instrument's real-time clock.



#### **CAUTION**

To avoid the risk of human injury and/or equipment damage, only use Evident batteries (P/N: OMNI-A-BATT [U8760010]) in the OmniScan X3.

---

### 3.4.1 Battery Status Indicators

The battery status indicators at the top of the display screen indicate the amount of power remaining in the batteries:

- The percentage of remaining power is displayed next to the indicators. The OmniScan X3 flaw detector must be turned on for approximately 15 minutes before it is able to accurately display this information.
- The bar length in the battery status indicator represents the approximate amount of power remaining in each battery (for example, 70% ).

---

**IMPORTANT**

The maximum ambient temperature for OmniScan X3 battery discharging is 45°C (the maximum OmniScan X3 operating temperature).

---

---

**NOTE**

If you attempt to turn on the OmniScan X3 with one or two batteries that are too low for operation, the power indicator light blinks red rapidly for about three seconds. Replace the battery or batteries, or plug in the DC power adaptor to operate the OmniScan X3.

---

Figure 3-2 on page 46 provides details about the variations of the battery charge indicator.

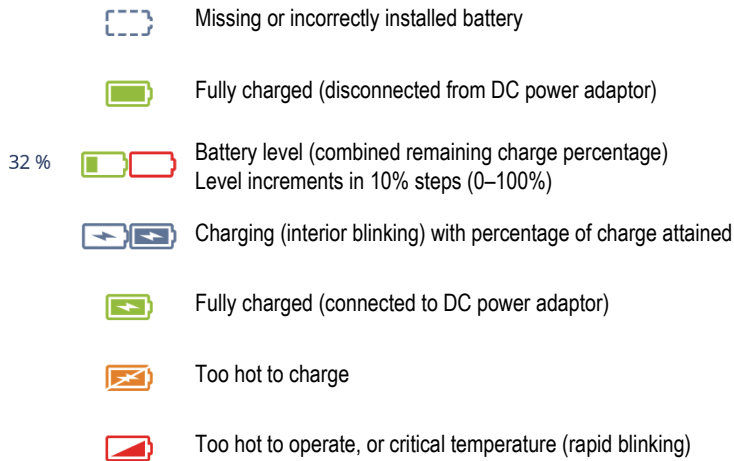
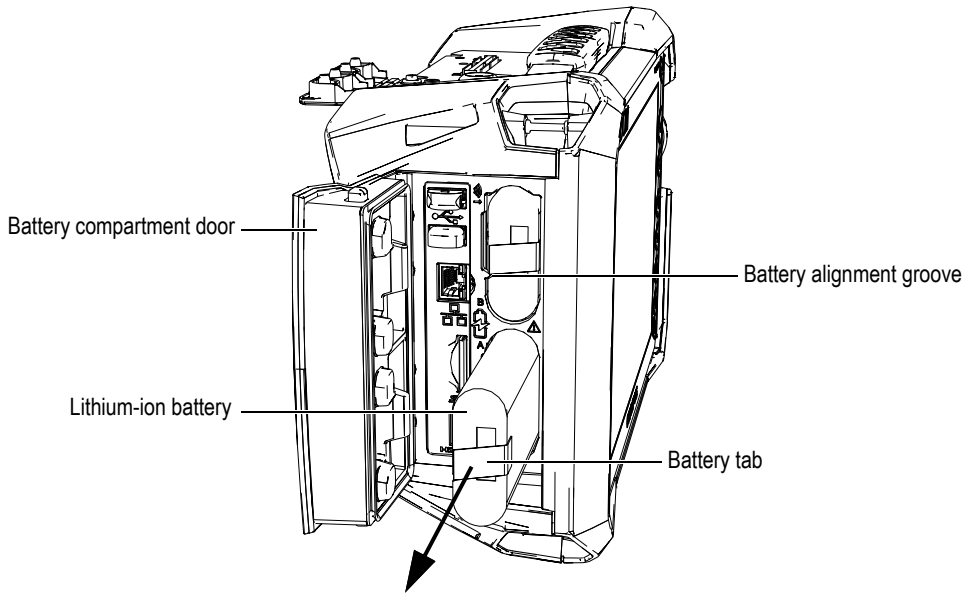

**Figure 3-2 Battery indicator variations**

## 3.4.2 Removing and Installing a Battery

### To remove and install a battery

1. On the left side panel, push the two latches to open the battery compartment door.
2. Push the battery inward, then pull leftward on the battery tab, and pull the battery out (see Figure 3-3 on page 47).



**Figure 3-3 Removing a lithium-ion battery**

3. Align the groove on the new battery with the key in the compartment, push the battery into the compartment until it bottoms, and then pull rightward to lock it in place.
4. Close the battery compartment door.  
Make sure that both latches lock when the door is closed.

The battery is recharged inside the OmniScan X3 flaw detector when it is connected to a DC power adaptor. Connecting the adaptor automatically starts the recharging process. The battery can also be recharged using an optional external battery charger (P/N: OMNI-A-CHRG [U8767077]).

### 3.4.3 Charging a Battery

---

#### IMPORTANT

The maximum ambient temperature for OmniScan X3 battery charging is 30°C. Above this temperature, the battery will not charge, although the OmniScan X3 flaw detector can be operated up to a maximum ambient temperature of 45°C.

---



#### WARNING

The OmniScan X3 DC power adaptor (P/N: OMNI-A-AC [U8767093]) is designed to power the OmniScan X3 and charge the lithium-ion batteries only (P/N: OMNI-A-BATT [U8760010]). Do not attempt to charge any other type of battery or use any other chargers/adaptors (except those recommended by Evident—for example, the optional external battery charger P/N: OMNI-A-CHRG [U8767077]). Doing so might cause an explosion or injury. Do not attempt to power or charge other electronic equipment with the DC power adaptor (P/N: OMNI-A-AC [U8767093]) or external battery charger (P/N: OMNI-A-CHRG [U8767077]), unless specifically instructed in the manual. Misuse of the DC power adaptor or external battery charger can cause other batteries and/or instruments to explode, which could lead to serious injury or death.

---

#### IMPORTANT

The lithium-ion batteries are not fully charged when the OmniScan X3 is shipped. You must charge the batteries for two to three hours before using the battery power to operate the OmniScan X3.

---

#### To charge a battery

- ◆ Connect the OmniScan X3 flaw detector to the DC power adaptor that is connected to an appropriate AC power source.

OR

Insert a battery into the optional external battery charger (P/N: OMNI-A-CHRG [U8767077]) that is connected to an appropriate AC power source.

---



Battery charging in the OmniScan X3 flaw detector is performed as follows:

- When the OmniScan X3 is turned off:

When the OmniScan X3 is connected to a proper DC power source and is turned off, it will automatically recharge the battery.

The power indicator light flashes orange to indicate that the battery is currently being recharged. When the charge is complete, the power indicator light emits a steady orange light. The battery can take up to 3 hours to fully charge from a completely discharged state (less than 5% remaining charge).

- When the OmniScan X3 is running:

When the OmniScan X3 is running and connected to a proper DC power source, it will automatically recharge the battery. The power indicator light is green during charging (when running).

Because the OmniScan X3 is running, less power is available from the DC source to recharge the battery. As such, it could take up to 8 hours to charge a completely discharged battery. For more information about battery charge status, see “Battery Status Indicators” on page 45.

### 3.4.4 Storing Batteries and Extending Life

This section describes lithium-ion battery care and maintenance.

#### To store batteries

1. Drain, recharge, and store as follows:

- ◆ Before recharging, drain the battery by running the OmniScan X3 flaw detector on battery power until it shuts down or until you get a low-battery warning. Do not leave the battery dormant for long periods of time. Evident recommends using the battery at least once every two to three weeks. If a battery has not been used for a long period of time, perform the steps of “To extend the life of batteries” on page 50.

If you do not plan to use the OmniScan X3 on battery power within three or more weeks, charge the battery to between 40% and 80% capacity (three or four bars on the charge indicator on the battery), and then remove and store the battery in a clean, cool, and dry place.

---

<b>NOTE</b>
-------------

Even when the OmniScan X3 is turned off and unplugged, it draws a small amount of power from the battery, which could completely discharge the battery in about 3 months at room temperature (25°C [77°F]).

---

2. Check the remaining charge of any stored batteries approximately once a month to ensure that they have 40% to 80% remaining capacity, and recharge any that do not. This is necessary because lithium-ion batteries self-discharge over time. Failure to do so may render a battery permanently unusable if it falls below a critical level (less than 1%).
3. When you are ready to use a battery after an extended period of storage, recharge it before use.

### To extend the life of batteries

1. Anytime you acquire a new rechargeable lithium-ion battery, use it four to eight times consecutively in the OmniScan X3, and ensure that you completely discharge and recharge it after each use. Doing so will enable it to reach maximum capacity, providing maximum run time.
2. After the first 10 to 15 periods of normal use (or after two to three weeks), it is good practice to completely discharge and recharge the battery to maintain a good run time and maximize battery life.

---

<b>NOTE</b>
-------------

Frequently switching from external DC power to battery power and vice versa may result in shorter battery life, because the charge/discharge cycles are limited (approximately 300 cycles). Even a partial discharge and recharge of the battery represents one cycle.

---

3. To maximize battery life, before charging, always run the OmniScan X3 on battery power until it shuts down, or until you get a low-battery warning. For a shorter recharge time, recharge the battery in the OmniScan X3 while it is turned off, or recharge using an optional external battery charger (**Recalibrate** button).

### 3.4.5 Used Battery Disposal

Although lithium-ion batteries do not contain any environmentally hazardous components such as lead or cadmium, the batteries should be disposed of in accordance with local regulations. Batteries should be disposed of in a discharged state to avoid heat generation and, if applicable, in accordance with the European Directive on Waste Electrical and Electronic Equipment (WEEE). Refer to your local Evident distributor for return and/or collection systems available in your country. Also see “Regulations for Shipping Products with Lithium-Ion Batteries” on page 15.

### 3.4.6 Warnings on Battery Use

Carefully read and observe the following warnings on battery use.



#### WARNING

- Do not open, crush, or perforate batteries; doing so could cause human injury.
  - Do not incinerate batteries. Keep batteries away from fire and other sources of extreme heat. Exposing batteries to extreme heat (over 80°C [176°F]) could result in an explosion or personal injury.
  - Do not drop, hit, or otherwise abuse a battery, as doing so could expose the cell contents, which are corrosive and explosive.
  - Do not short-circuit the battery terminals. A short circuit could cause injury and severe damage to a battery, making it unusable.
  - Do not expose a battery to moisture or rain; doing so could cause an electric shock.
  - Only use the OmniScan X3 flaw detector or an external battery charger approved by Evident to charge the battery.
  - Do not recharge a battery unless the indicators light up when the capacity check button on the battery is pressed. Doing so could be dangerous.
  - Do not store batteries that have less than 40% remaining charge. Recharge batteries to between 40% and 80% capacity before storing them.
  - During storage, keep the battery charged to between 40% and 80%.
  - Do not leave the battery in the OmniScan X3 during instrument storage.
-

## 3.5 Software

The OmniScan X3 flaw detector operates using OmniScan MXU software, which may periodically be updated. For details, refer to the *OmniScan MXU Software User's Manual*. You can download the latest MXU software version at [EvidentScientific.com](http://EvidentScientific.com).

## 3.6 Global Positioning System (GPS)

The OmniScan X3 flaw detector incorporates a GPS, which provides the geographic coordinates (location) of the instrument. The GPS is automatically activated when the OmniScan X3 is turned on. After the OmniScan X3 is turned on, there may be a delay of up to two minutes before it is able to obtain the coordinates.

---

<b>NOTE</b>
-------------

GPS functionality is not available in all countries. Contact your local Evident representative for details.

---

---

## 4. Maintenance and Troubleshooting

---

The OmniScan X3 flaw detector only requires minimal maintenance to keep it in good physical and working condition.

### 4.1 Preventative Maintenance

The OmniScan X3 does not have many moving parts; it therefore only requires minimal preventative maintenance. Simply perform regular inspections to keep the OmniScan X3 in proper working order. Any dust that has accumulated on the fan can be carefully cleaned away. If damaged or malfunctioning, fan components can be changed. The touch-screen protector can be replaced if it is overly dirty or damaged. The following sections detail these maintenance procedures.

### 4.2 Instrument Cleaning

The OmniScan X3 flaw detector's external surfaces may be cleaned as needed. This section provides the appropriate procedure for cleaning the instrument.

#### 4.2.1 Cleaning the Casing

##### To clean the casing

1. Make sure that the OmniScan X3 flaw detector is turned off and the power cord is disconnected.
2. Disconnect all cables and connectors, and make sure that all external ports and connectors (including PA probe connector) on the OmniScan X3 have been covered with their caps.

3. Make sure that the battery compartment door is closed correctly.
4. To restore the instrument's original finish, clean the casing with a soft cloth.
5. To remove persistent stains, use a damp cloth with a mild, soapy solution. Do not use abrasive products or powerful solvents, which could damage the finish.
6. After you have finished cleaning and the connector protectors are removed, make sure that the connectors are dry before connecting anything to them. If they are wet, carefully dry them, or let them air dry.

## 4.2.2 Cleaning the Screen and Screen Protector

Never use abrasive products or powerful solvents to clean the OmniScan X3 touch screen and screen protector. Clean the touch screen and screen protector using a damp cloth moistened with a standard, evaporating glass cleaner. If necessary, remove any paper-towel residue with a soft-bristle brush.

## 4.2.3 Cleaning or Changing the Fan

If the cooling fan is dirty or functioning incorrectly, the OmniScan X3 flaw detector may overheat.

### To clean or change the fan

1. Check for presence of dust or dirt in the fan openings and carefully blow it away using compressed air in any direction from the exterior of the enclosure (maximum pressure 207 kPa [30 psi]), but do not blow directly into the cable hole in the fan enclosure (see Figure 4-1 on page 55).



### CAUTION

To avoid damaging the instrument seal, do not blow compressed air directly into the cable hole in the fan enclosure.

---

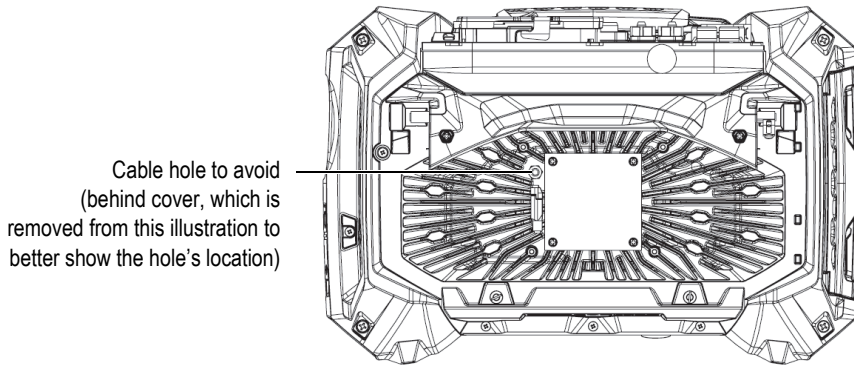

**Figure 4-1 Interior of cooling fan enclosure (cover removed to show cable hole)**

2. If it is difficult to clean from the exterior of the enclosure or if the fan appears to need servicing, remove the fan cover—and, if necessary, the fan—and carefully clean the part surfaces as required (see Figure 4-2 on page 56).
3. If the fan is damaged or malfunctioning, carefully disconnect the cable (Figure 4-3 on page 56) and replace the fan with a new one.
4. If the fan cable was disconnected or moved, make sure that it is properly reconnected and placed for reassembly (see Figure 4-3 on page 56).
5. Reassemble the parts in reverse order, and sufficiently tighten all screws.

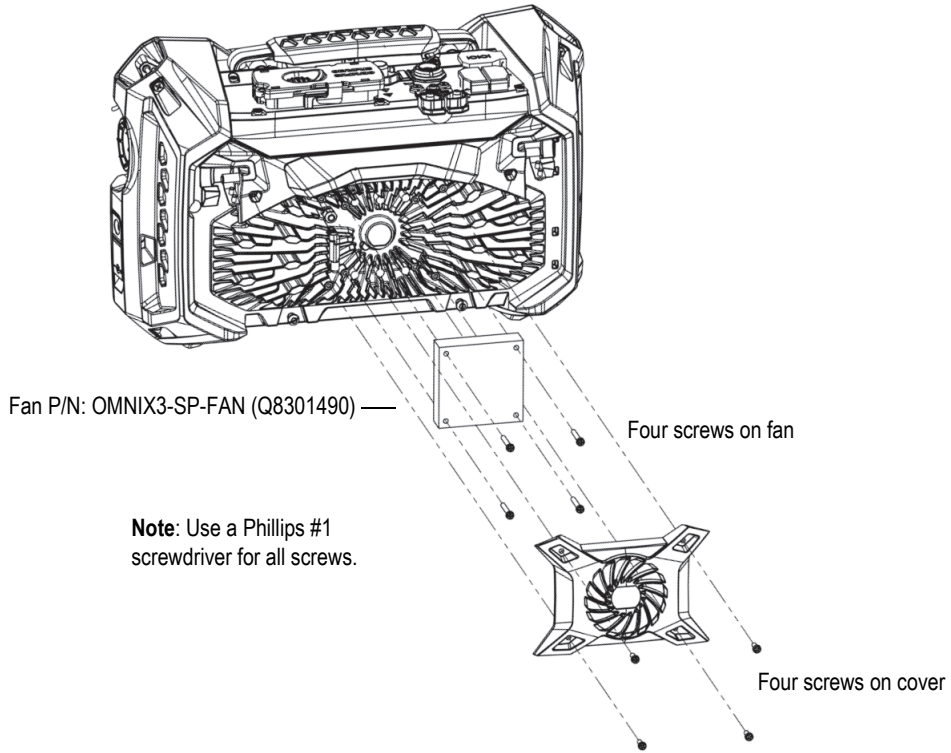

**Figure 4-2** Assembly of fan and cover parts

Use a flathead screwdriver to pull up the tab, and then disconnect the cable.

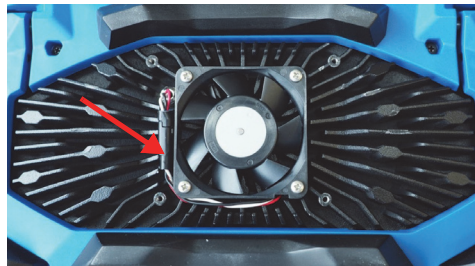
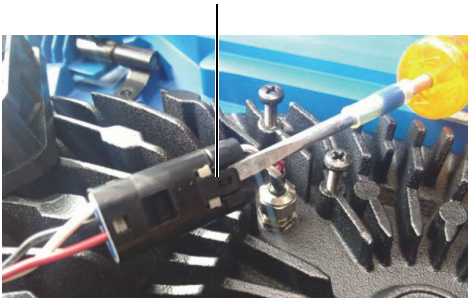

**Figure 4-3** Fan cable disconnection (*left*) and final placement (*right*)



---

## 4.3 Replacing the Touch-Screen Protector

This section explains how to replace the touch-screen protector.

### To replace the touch-screen protector

1. Remove any dust or dirt on the touch screen (dust and dirt cause bubbles to appear on the protective film). See “Cleaning the Screen and Screen Protector” on page 54.

---

**TIP**

Use a can of compressed air to blow away any dust particles that may be on the touch screen and screen protector.

2. Remove the label marked No. 1, and peel away the protective film on the back.

---

**NOTE**

Avoid touching the back of the screen protector after the protective film on the back is peeled away. Doing so will leave a trace of your finger prints.

3. Align the protector into the correct position on the screen, and slowly install the screen protector.
4. Remove the label marked No. 2, and peel away the film on the front. Provided that there is no dust trapped underneath, all small bubbles will dissipate within 48 hours.

## 4.4 Troubleshooting

see Table 4 on page 58 lists some problems that may arise during operation, and it provides possible causes and suggested solutions. It is presumed that the OmniScan X3 flaw detector has not been modified and that all cables and connectors used are those provided and documented by Evident.

**Table 4 Troubleshooting guide**

<b>Problem</b>	<b>Possible cause</b>	<b>Solution</b>
OmniScan X3 flaw detector does not start up.	DC power connection	Check that the DC power adaptor is connected to both the OmniScan X3 and a power outlet with the proper voltage. Only use the adaptor supplied with the OmniScan X3.
	Battery connection or charge	Make sure that the battery is charged to at least 10% capacity and correctly inserted into the battery compartment.
	Power key (  ) press	Press and hold the Power key for three seconds or longer.
OmniScan X3 battery does not charge.	Incompatible battery	Make sure that the battery model used in the OmniScan X3 is compatible with the model suggested by Evident. An incompatible battery may be able to power the unit, but the recharge protocol may not recognize it.
	DC power adaptor connection	Make sure that the DC power adaptor is connected correctly.
	Charging method	Charge the battery using an external battery charger. The battery charges much quicker when the OmniScan X3 is not in use. However, the battery will charge very slowly, if at all, if the power consumption is too high.
	Elevated temperature	Shut down the OmniScan X3 and wait for it to cool. Battery charging is disabled when the battery temperature or the system's internal temperature is too high. This status will be indicated on the battery status indicator (see "Battery Status Indicators" on page 45 for more details). Check if the instrument's cooling fan is functioning correctly, and clean or change it if needed (see "Cleaning or Changing the Fan" on page 54).

**Table 4 Troubleshooting guide (continued)**

<b>Problem</b>	<b>Possible cause</b>	<b>Solution</b>
Low battery life (does not last as long as it used to)	Battery drain before charging	Drain the battery completely before recharging it to extend its life.
	Battery needs reconditioning	Recondition the battery once a month using an external battery charger ( <b>Recalibrate</b> button), according to the instructions in “Storing Batteries and Extending Life” on page 49. Although the OmniScan X3 lithium-ion battery does not suffer from the “memory effect” commonly affecting other battery types, it should be reconditioned for optimum efficiency.
	Instrument configuration	Verify your current configuration. There may be an option or combination of options that are causing the battery to drain too quickly. Such options could include the brightness, voltage level, and acquisition rate.



## 5. Specifications

This chapter covers the OmniScan X3 flaw detector's general specifications, as well as the acoustic, acquisition, and data specifications of the acquisition connectors.

### 5.1 General Specifications

The general specifications are provided in see Table 5 on page 61.

**Table 5 OmniScan X3 general specifications**

<b>Housing</b>	
Size (width × height × depth)	335 mm × 221 mm × 151 mm (13.2 in. × 8.7 in. × 5.9 in.)
Weight	5.7 kg (12.6 lb) [with one battery inside]
<b>Environmental conditions</b>	
Operating temperature	-10°C to 45°C (14°F to 113°F)
Storage temperature	-20°C to 60°C [-4°F to 140°F] (with battery inside) -20°C to 70°C [-4°F to 158°F] (with no battery inside)
Relative humidity (RH)	Max. 70% RH at 45°C (113°F) noncondensing
Altitude	Up to 2000 m
Outdoor use	Yes: battery power must be used, door must be closed, connectors must be covered or connected.
IP rating	IP65 Certified
Thermal shock	Standard MIL-STD 810G Method 503.5 Procedure I-C, Figure 503.5-3
Random vibration	Standard MIL-STD 810G Method 514.6 Procedure I, Category 7

**Table 5 OmniScan X3 general specifications (continued)**

Sinusoidal vibration (loose cargo test)	Standard MIL-STD 810G Method 514.6 Procedure II, Category 5
Mechanical shock	Modified MIL-STD 810G Method 516.6 Procedure I: acceleration of 15 g (0.5 oz.) instead for a duration of 11 ms
Transit drop	Standard MIL-STD 810G Method 516.6 Procedure IV, Table 516.6-VI
Pollution level	2
Installation category	II
<b>Battery</b>	
Battery model	OMNI-A-BATT (U8760010)
Battery type	Smart lithium-ion battery
Number of batteries	2
Battery storage temperature	-20°C to 60°C (-4°F to 140°F) at 80% relative humidity
Battery charge time	Typically 3 hours per battery, depending on ambient temperature (max. 30°C), using the internal charger or an optional external battery charger
Battery life	5 hours of continuous instrument operation using two batteries
Size	Approximately 214 mm × 58.7 mm × 21.9 mm (8.4 in. × 2.3 in. × 0.9 in.)
<b>External DC supply (DC power adaptor)</b>	
DC-IN voltage	15 VDC to 18 VDC (min. 50 W)
Connector	Circular, 2.5 mm pin diameter, center-positive
Model	OMNI-A-AC (U8767093)
<b>Display</b>	
Display size (diagonal)	269 mm (10.6 in.)
Resolution	1280 × 768 pixels
Number of colors	16 million
Type	TFT LCD with resistive touch screen
Viewing angles	Horizontal: -85° to 85° Vertical: -85° to 85°

**Table 5 OmniScan X3 general specifications (continued)**

<b>Data storage</b>	
External storage devices	Supports standard USB, SDHC, and SDXC storage devices. Supports devices formatted to NTFS or FAT32 file systems. Storage is extensible using external USB drive.
Maximum data file size	25 GB
Onboard storage	SSD drive, 64 GB total (OmniScan X3) or 1 TB total (OmniScan X3 64)
<b>I/O ports</b>	
USB ports	Two USB 2.0 ports (one hidden behind battery) One USB 3.0 port
Video output	Video out (HDMI)
Memory card	SDHC port
Communication	Ethernet
<b>I/O lines</b>	
Encoder inputs	2-axis currently supported (quadrature or clock/direction) Third encoder capable (future expansion)
Digital input	6 digital inputs, TTL
Digital output	5 digital outputs, TTL
Acquisition on/off switch	Through configuration of a digital input
Power output	5 V nominal, 1 A (short-circuit protected) and 12 V output at 1 A (short-circuit protected)

## 5.2 Acquisition Connector Specifications



### CAUTION



- To reduce the risk of electric shock, avoid touching the inner conductor of the LEMO connectors. Up to 350 V can be present on the inner conductor of the UT connectors, and up to 120 V can be present on the PA connector. The warning symbols near the LEMO connectors signals this electric shock risk (see Figure 5-1 on page 64).

- Reinforced insulation must be provided for the probes connected to the instrument.
- 

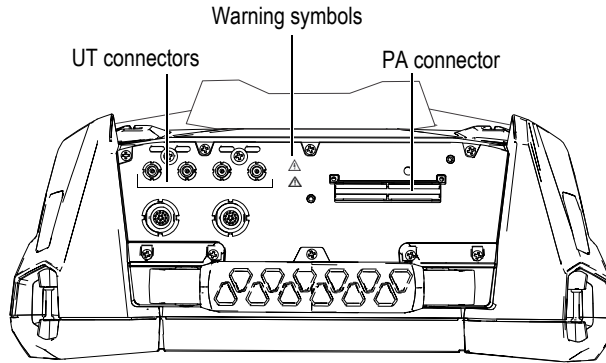

**Figure 5-1 Acquisition connectors**

When the UT channel is the only channel used, place the PA connector cap over the PA connector to protect it against dirt and water.

---

**NOTE**

Before using a phased array probe that is not equipped with a latching PA connector (shown in Figure 2-6 on page 35), remove the anchor base, which is secured by two screws.

---

## 5.2.1 Acoustic Specifications

This section details the acoustic specifications of the pulser, receiver, and beam formation, for both UT and PA modes (see Table 6 on page 65 and see Table 7 on page 65).



**Table 6 Acoustic specifications—UT channel using UT connector**

<b>Certification</b>	
Calibration certification	ISO 22232
<b>Pulser</b>	
Voltage	85 V, 155 V, and 295 V
Pulse width	Adjustable from 30 ns to 1000 ns; resolution of 2.5 ns
Fall time	<10 ns
Pulse shape	Negative square pulse
Output impedance	<30 $\Omega$
<b>Receiver</b>	
Gain range	0 dB to 120 dB; maximum input signal 30 Vp-p (full-screen height)
Input impedance	50 $\Omega$ in pulse-echo mode 50 $\Omega$ in pitch-catch mode
System bandwidth	0.25 MHz to 28.5 MHz

**NOTE**

When the UT channel is used in pulse-echo mode, pulses occur on both the P1 and R1 connectors. When pulse-echo mode is selected, Evident recommends using only one probe on the P1 connector.

**Table 7 Acoustic specifications—PA channel**

	OmniScan X3	OmniScan X3 64
<b>Certification</b>		
Calibration certification	ISO 18563-1:2015	
<b>Pulser</b>		
Voltage	40 V, 80 V, and 115 V	10 Vpp, 20 Vpp, 40 Vpp, 80 Vpp, 120 Vpp, and 160 Vpp

**Table 7 Acoustic specifications – PA channel (continued)**

Pulse width	Adjustable from 30 ns to 500 ns; resolution of 2.5 ns	Adjustable from 30 ns to 1000 ns (half period of bipolar pulse or duration of negative of pulse); resolution of 5 ns
Fall time	<10 ns	
Pulse shape	Negative square pulse	Bipolar negative-positive square pulse, Negative square pulse
Output impedance	28 $\Omega$ in pulse-echo 24 $\Omega$ in pitch-catch	35 $\Omega$
<b>Receiver</b>		
Gain range	0 dB to 80 dB; maximum input signal 800 mVp-p (full-screen height).	0 dB to 80 dB; maximum input signal 900 mVp-p (full-screen height).
Input impedance	57 $\Omega$ $\pm$ 10% at 9 MHz in pulse-echo 100 $\Omega$ $\pm$ 10% at 9 MHz in pitch-catch	120 $\Omega$ $\pm$ 10% at 13 MHz
System bandwidth	0.5 MHz to 18 MHz	0.2 MHz to 26.5 MHz
<b>Beam formation</b>		
Scan type	Single, linear, sectorial, compound, and TFM (includes FMC and AIM)	
Pulsing maximum aperture	OMNIX3-PATFM1664PR = 16 elements OMNIX3-PATFM16128PR = 16 elements OMNIX3-PATFM32128PR = 32 elements	OMNIX3-PATFM64128PR = 64 elements
Total number of receiving elements	OMNIX3-PATFM1664PR = 64 elements OMNIX3-PATFM16128PR = 128 elements OMNIX3-PATFM32128PR = 128 elements	OMNIX3-PATFM64128PR = 128 elements
Number of focal laws	1024 maximum total (512 maximum per group)	
Delay range transmission	0 $\mu$ s to 10 $\mu$ s in 2.5 ns increments	0 $\mu$ s to 10 $\mu$ s in 5 ns increments
Delay range reception	0 $\mu$ s to 6.4 $\mu$ s in 2.5 ns increments	

## 5.2.2 Acquisition Specifications

This section lists the acquisition specifications for frequency, data display, and synchronization (see Table 8 on page 67).

**Table 8 Acquisition specifications**

Frequency	
Effective digitizing frequency	Up to 100 MHz (16 bits)
Maximum pulsing rate	Up to 20 kHz
Display	
Refresh rate	A-scan: 60 Hz; S-scan: 20 Hz to 30 Hz
Synchronization	
On internal clock	1 Hz to 10 kHz
On encoder	On 2 axes: from 1 to 65536 steps

## 5.2.3 Data Specifications

This section details the data specifications of processing, TCG, and TFM/FMC (see Table 9 on page 67).

**Table 9 Data specifications**

Processing	
Maximum number of A-scan data points	Up to 16384
Real-time averaging	PA: 2, 4, 8, 16 UT: 2, 4, 8, 16, 32, 64
Rectification	RF, full wave, half wave+, half wave-
Filtering	PA channel (OmniScan X3): 8 low-pass, 6 band-pass, and 4 high-pass filters PA channel (OmniScan X3 64): 9 band-pass and 7 high-pass filters UT channel: 8 low-pass, 6 band-pass, and 4 high-pass filters (3 additional filters when configured in TOFD)

**Table 9 Data specifications (continued)**

Video filtering	Smoothing (adjusted to the probe frequency range)
<b>Programmable TCG</b>	
Number of points	32: one TCG (time-corrected gain) curve per focal law
Range	PA: 40 dB per step of 0.1 dB UT: 100 dB per step of 0.1 dB
Maximum slope	PA: 40 dB/10 ns UT: 40 dB/10 ns
<b>TFM/FMC</b>	
Supported modes	Pulse-echo: L-L, TT, and TT-TT Self-tandem: TT-T, TT-TTT, LL-L, LT-T, TL-T, TT-L, and TL-L
Parallel multimode TFM	4 simultaneous TFM groups (wave sets)
Live envelope process	Yes
Maximum aperture	64-element aperture for 64:128PR 64-element extended aperture (32:128PR only) 32-element extended aperture for 16:64PR and 16:128PR 128-element extended aperture for 64:128PR
Image resolution	Up to 1024 × 1024 points [for each TFM wave set]

---

## 6. Connector References

---



### WARNING

Always use equipment and accessories that meet Evident specifications. Using incompatible equipment can result in a malfunction, equipment damage, or human injury.

---

This chapter provides technical descriptions for the following two OmniScan X3 connectors:

- Scanner encoder connector
- Alarm and I/O connector

The following information is provided for both connectors: a brief description, the manufacturer's number, the number of the corresponding cable connector, an illustration, and a table with the signal pinout for the connector.

The following OmniScan X3 connectors comply with their respective standards:

- SDHC (memory card slot)
- Circular DC power jack, 2.5 mm pin diameter, 15 VDC to 18 VDC  
(polarity: ⊕ — ⊙ — ⊖)
- USB 2.0 and USB 3.0
- Ethernet
- HDMI

## 6.1 Scanner Encoder Connector

### Description

LEMO, 16-pin female circular connector

### Manufacturer, number

LEMO, EEG.1K.316.CLL

### Suggested cable connector

LEMO, FGG.1K.316.CLAC65Z

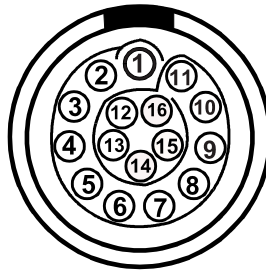

Figure 6-1 Scanner encoder LEMO connector (contact view)

Table 10 Pinout for the scanner encoder LEMO connector

Pin	I/O	Signal	Description
1			NC <sup>a</sup>
2	Out	+5 V	External power supply, 1 A <sup>b</sup> , +5 V
3	In	DIN1	Digital input 1, TTL
4	In	DIN2	Digital input 2, TTL
5	In	DIN3	Digital input 3, TTL
6	In	DIN4	Digital input 4, TTL
7	Out	DOUT1	Digital output 1, ±20 mA, TTL
8	Out	DOUT2	Digital output 2, ±20 mA, TTL

**Table 10 Pinout for the scanner encoder LEMO connector (continued)**

Pin	I/O	Signal	Description
9	In	PhA1	Encoder 1 / Phase A_CLK, TTL
10	In	PhB1	Encoder 1 / Phase B_DIR, TTL
11	In	PhB2	Encoder 2 / Phase B_DIR, TTL
12	In	PhA2	Encoder 2 / Phase A_CLK, TTL
13	Out	DOU3	Digital output 3, $\pm 20$ mA, TTL
14	–	_c	–
15	–	_d	–
16	–	GND	Ground

- a. NC = Not connected.
- b. Shared with Alarm and I/O connector.
- c. Reserved for future use
- d. Reserved for future use

## 6.2 Alarm and I/O Connector

### Description

LEMO, 14-pin female circular connector

### Manufacturer, number

LEMO, HMA.1K.314.CLLP

### Suggested cable connector

LEMO, FGA.1K.314.CLAC65Z



Figure 6-2 Alarm and I/O LEMO connector (contact view)

Table 11 Pinout for the Alarm and I/O connector

Pin	I/O	Signal	Description
1	-	NU <sup>a</sup>	-
2	-	NU	-
3	-	NU	-
4	-	NU	-
5	-	NU	-
6	-	NU	-
7	Out	5 V	5 V external power supply, 1 A <sup>b</sup>
8	-	NU	-
9	-	NU	-
10	-	NC <sup>c</sup>	
11	-	NC	
12	-	NU	-
13	Out	12 V	12 V external power supply, 1 A
14	-	GND	Ground

a. NU = Not used.

b. Shared with Encoder connector.

c. NC = Not connected.



---

## 7. Connection to a PC with WeldSight Remote Connect

---

This chapter describes how to connect an OmniScan X3 flaw detector to a PC (WeldSight Remote Connect).

### 7.1 Launching WeldSight Remote Connect

#### To do before the first launch

1. Install WeldSight on your computer if it is not already done. A WeldSight license is required to acquire data in WeldSight. With a WeldSight Analysis license, you will only be able to analyze data files acquired on the on-board software MXU.
2. Configure the Ethernet network card of the PC with a fixed IP address.
  - a) Open the list of network connections in the Windows Control Panel, and identify the connection used to connect to the OmniScan X3. Find the Ethernet card network, right-click on it and select **Properties**.
  - b) Double-click on the **TCP/IPv4** settings (see Figure 7-1 on page 74).

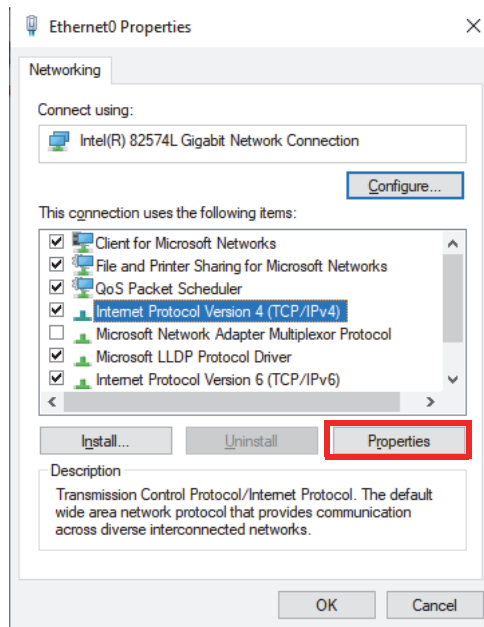

Figure 7-1 Ethernet Properties dialog box

- c) Check the **Use the following IP address** and set it to:
  - o **IP Address: 192.168.0.1**
  - o **Subnet mask: 255.255.255.0**
- d) Click **Ok** to accept the changes.

---

**NOTE**

The IP address can be different than the one suggested, but it must be on the same subnetwork than the OmniScan X3. The default IP address of the instrument is **192.168.0.2**, but if you need to use a different subnet, change it in the WeldSight Remote Connect application, in your network card settings, as well as in WeldSight (instrument settings).

- e) For optimum performance, and to avoid data loss, in the **Properties** of the same network card, click **Configure** (Figure 7-1 on page 74), then go to the **Advanced** tab.

- On the **Advanced** tab, under **Properties** select **Jumbo Packet** or **Jumbo Frames** and then under **Value** change the value to **9014 Bytes** (see Figure 7-2 on page 75).

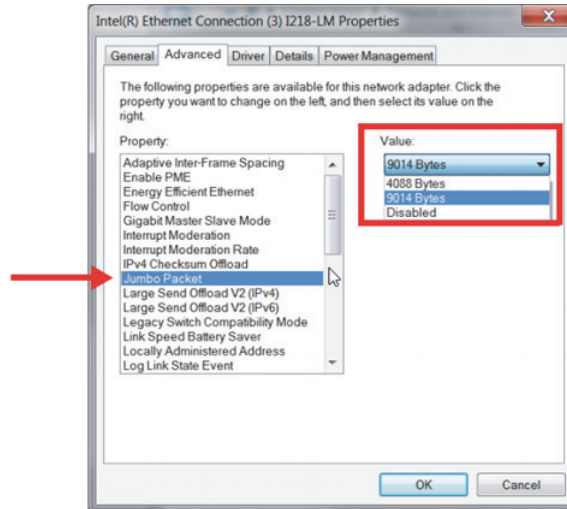

Figure 7-2 Jumbo Packet setting

- On the **Advanced** tab under **Properties**, select **Speed & Duplex** and then under **Value**, change the value to **1.0 Gpbs Full Duplex** or **Auto-Negotiation** (see Figure 7-3 on page 76).

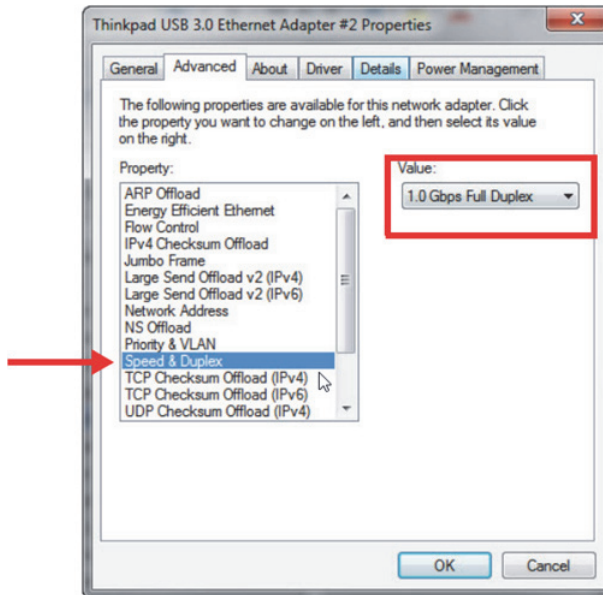



Figure 7-3 Speed & Duplex setting

- f) On your PC, open WeldSight  and double-click on the PC icon  (see Figure 7-4 on page 77) located in the right bottom corner of the screen. Click **Advanced Settings**, and make sure that:
- The value of **Network Card IP Address** is also set to **192.168.0.1**.
  - The **Device Discovery Mode** is set to **Single Device**.

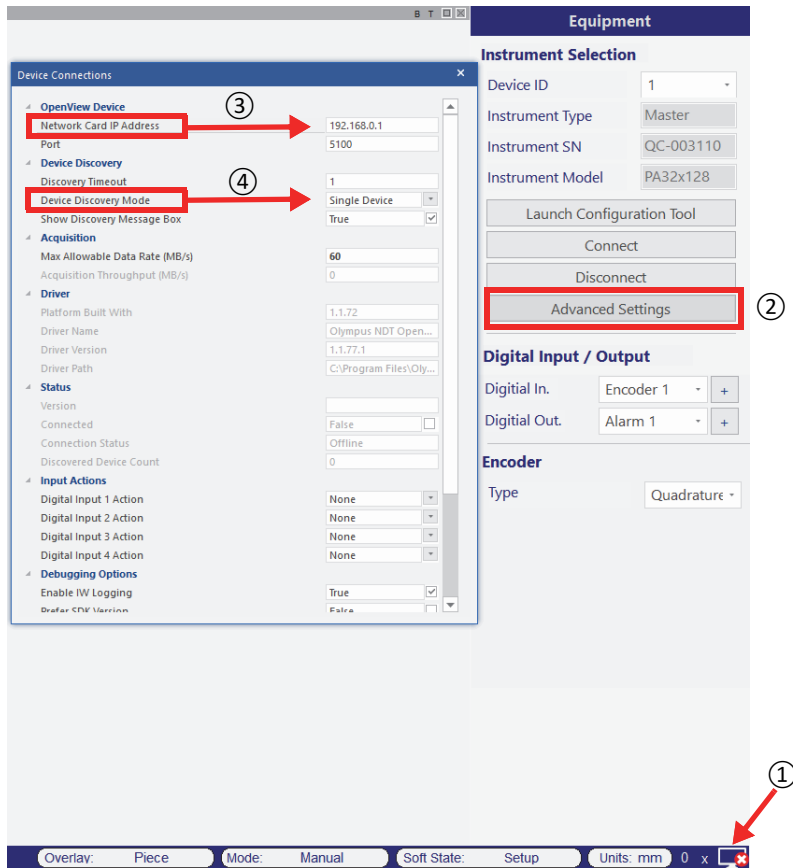

Figure 7-4 Configuration in WeldSight

g) When everything is configured, close WeldSight.

## 7.2 Connecting the OmniScan X3 to WeldSight

### To connect the OmniScan X3 to WeldSight

1. Boot the OmniScan X3.
2. Connect an Ethernet cable between your PC and the OmniScan X3. The cable must be minimally a CAT 5e.

3. Launch WeldSight Remote Connect on the OmniScan X3.
4. Launch the WeldSight Remote Connect application on the OmniScan X3.
5. The status in WeldSight Remote Connect should go from **Not Ready** to **Ready** when the OmniScan X3 detects a valid connection with the PC (see Figure 7-5 on page 78).

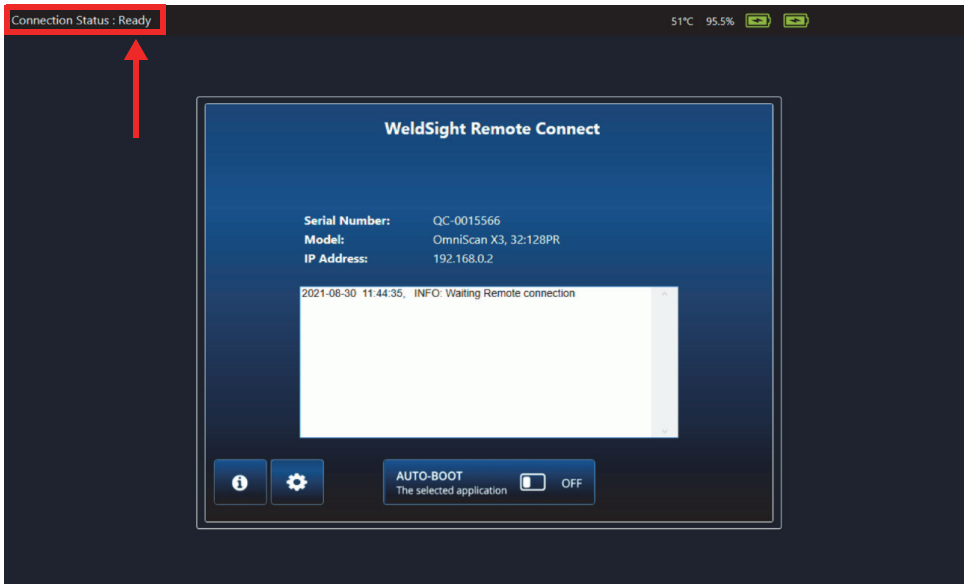

**Figure 7-5 Connection status — Ready**

6. Launch WeldSight on the PC.
7. If everything is configured correctly, the status in WeldSight Remote Connect should go from **Ready** to **Connected** (see Figure 7-6 on page 79).

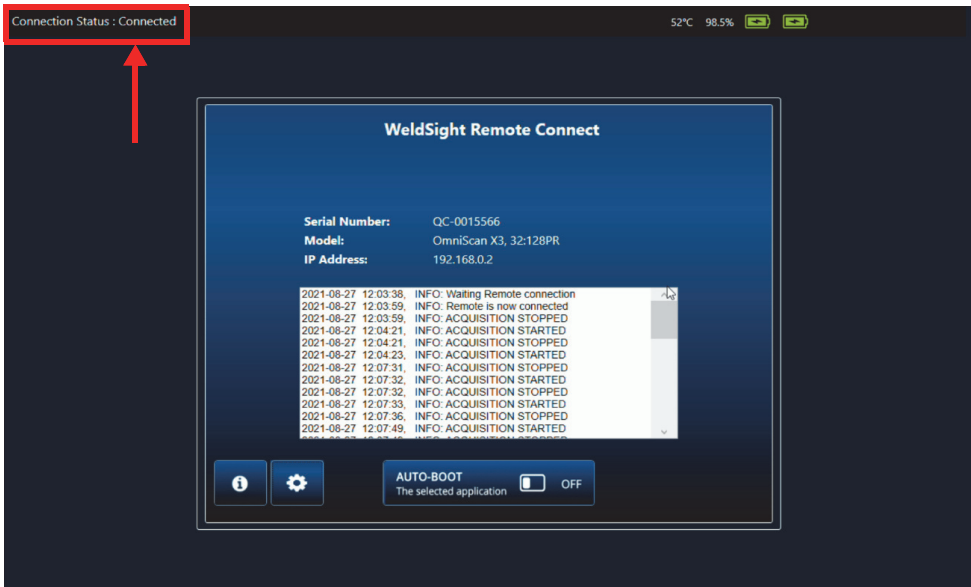

**Figure 7-6 Connection status – Connected**

The PC icon in the right bottom of the screen of WeldSight should have a green checkmark (  ).





## Appendix: Accessories and Spare Parts

Table 12 on page 81 and Table 13 on page 82 list some typical accessories that are compatible with the OmniScan X3 flaw detector. However, this is not a complete list; compatible accessories are not limited to the items listed here. Table 14 on page 83 lists the OmniScan X3 spare parts.

**Table 12 Optional Items (sold separately on demand)**

Optional item (marketing code)	Part order number	Description
OMNI-A-BATT	U8760010	Lithium-Ion battery for OmniScan MX / MX2 / SX / X3
OMNI-A-CHRG	U8767077	External battery charger
OMNIX3-A-SCREENPROTEC	Q7800069	Kit of 5 anti-glare touch screen protectors for OmniScan X3
OMNIX3-A-HCASE	Q7640011	OmniScan X3 hard transport case
OMNIX3-A-SDCARD	Q7800068	OmniScan X3 recommended spare SDHC Card
OMNIX3-A-USBKEY	Q7750166	OmniScan X3 recommended spare USB Key
OMNI-A-BST	U8780089	OmniScan backstrap
PAPROBE-A-BASECAP	U8100138	PA probe connector cap
60ND0001	U8840124	Ethernet cross link cable RJ45 (3 meters)
WELDSIGHT-A	Q1480003	WeldSight Analysis software license key (compatible with data files from FOCUS PX and OmniScan X3 series). Includes data analysis functionalities only. Does NOT include data acquisition functionalities. Comes with one single hard USB key. NO replacement keys are available if lost.

**Table 12 Optional Items (sold separately on demand) (continued)**

Optional item (marketing code)	Part order number	Description
WELDSIGHTESBT-I	Q1480007	WeldSight Inspection software license key (compatible with FOCUS PX and OmniScan X3 series). Includes data acquisition and analysis functionalities, and ES BeamTool license. Comes with two hard USB keys (WeldSight-I and ES BeamTool). DOES NOT include a dedicated analysis key. NO replacement keys are available if lost.
OMNI-A-X3-SPDOOR	Q1000230	OmniScan X3 series special purpose side door upgrade kit – allows cables to be used when the door is closed. Includes: (1 ea.) OmniScan X3 series special purpose protective side door with room for accessories, (1 ea.) USB 3.0, 30 cm (1 ft.) extension, and (1 ea.) printed visual assembly instructions. NOTE: The special purpose door offers reasonable protection to objects from entering the OmniScan X3 but offers only minimal protection to rain or water. For using the OmniScan X3 into wet or extreme conditions, Evident recommends using the standard (sealed) door that is included with each OmniScan X3.

**Table 13 Compatible accessories**

Accessory (marketing code)	Part order number	Description
OMNI-A2-SPLIT128	U8100133	“Y” adaptor (splitter) with OmniScan connectors to support two phased array probes with a maximum of 64 elements each on a 128 channel OmniScan X3 flaw detector.
OMNI-A2-SPLIT128-4UT	U8100134	“Y” adaptor (splitter) with OmniScan connectors to support two phased array probes with a maximum of 62 elements each and 4 UT channels with LEMO 00 connectors on a 128 channel OmniScan X3 flaw detector. UT channels are connected to elements: 63, 64, 127, 128
OMNI-A2-ADP03	U8775202	Adaptor to connect PA probe with Hypertronic connector on an OmniScan X3 flaw detector with OmniScan connector.

**Table 13 Compatible accessories (continued)**

Accessory (marketing code)	Part order number	Description
EIB-T-8-M-5-OM	U8775086	Interbox extension and splitter with two PA connectors and two pairs of TOFD connectors that use a TRPP amplifier. Several models are available. For example, the accessory code EIB-T-8-M-5-OM indicates the following characteristics: <ul style="list-style-type: none"> <li>• EIB: Interbox extension</li> <li>• T: TRPP included or not (NT = no, T = yes)</li> <li>• 8: Number of UT connectors</li> <li>• M: Cable jacket type (P = PVC, M = metal)</li> <li>• 5: Cable length in meters (0 = 0.5 m)</li> <li>• OM: Instrument connector (OM = OmniScan connector, HY = Hypertronic connector)</li> </ul>
EIB-NT-0-P-10-OM	U8779855	
E128P0-0202-OM	U8800635	Extension cable with an OmniScan connector at both ends. Can be fitted with four LEMO 00 connectors enabling the simultaneous use of conventional UT and PA probes with a PA instrument. Several models are available. For example, the accessory code E128P0-0202-OM indicates the following characteristics: <ul style="list-style-type: none"> <li>• E: Extension cable</li> <li>• 128: number of elements</li> <li>• P: Cable jacket type (P = PVC, M = metal)</li> <li>• 0: Cable length in meters (0 = 0.5 m)</li> <li>• 0202: UT connectors configuration</li> <li>• OM: OmniScan connectors</li> </ul>
E128P0-0004-OM	U8800429	
E128P5-0202-OM	U8800442	
E128P10-0004-OM	U8800431	
E128P10-0202-OM	U8800432	
OMNI-A2-ADP20	U8775201	Cable with scanner encoder adaptor to connect scanner encoder cables with DE15 connector to OmniScan X3 flaw detector, which has a LEMO scanner encoder connector.

**Table 14 Spare parts**

Spare part (marketing code)	Part order number	Description
OMNIX3-SP-FAN	Q8301490	Fan (does not include fan cover)
OMNIX3-SP-BATTERYDOOR	Q8301491	Battery compartment door
OMNIX3-SP-STAND	Q8301492	Support stand
OMNIX3-SP-KNOB	Q8301493	Scroll knob (includes set screw)

**Table 14 Spare parts (continued)**

<b>Spare part (marketing code)</b>	<b>Part order number</b>	<b>Description</b>
OMNIX3-SP-DUSTCAPS	Q8301494	Kit of connector caps, including screws and washers (does not include PA connector cap)
PAPROBE-A-BASECAP	U8100138	PA probe connector cap
OMNIX3-SP-HANDLE	Q8301495	Handle for carrying the OmniScan X3
OMNI-A-WIRELESS-NA	Q7670059	LM Technologies LM808-0407 Wireless LAN USB adaptor for U.S.A. and Canada
OMNI-A-WIRELESS-INTL	Q7670060	LM Technologies LM808-0406 Wireless LAN USB adaptor for other countries than U.S.A. and Canada

---

## List of Figures

---

Figure 2-1	Front panel controls of the OmniScan X3 .....	27
Figure 2-2	Left side panel of the OmniScan X3 .....	31
Figure 2-3	Push the cover ( <i>left</i> ) and pull out the hidden USB 2.0 port ( <i>right</i> ) .....	32
Figure 2-4	Right side panel of the OmniScan X3 .....	33
Figure 2-5	Top panel of the OmniScan X3 .....	34
Figure 2-6	LEMO and phased array probe connectors .....	35
Figure 2-7	Rear panel of the OmniScan X3 .....	36
Figure 2-8	Four anchor points for a harness .....	37
Figure 2-9	Removing the compartment door .....	38
Figure 2-10	Inserting a cable into its port .....	38
Figure 2-11	Sliding the door over the aligned cables .....	39
Figure 2-12	Locking the special-purpose door in place .....	40
Figure 3-1	DC power adaptor plug .....	44
Figure 3-2	Battery indicator variations .....	46
Figure 3-3	Removing a lithium-ion battery .....	47
Figure 4-1	Interior of cooling fan enclosure (cover removed to show cable hole) .....	55
Figure 4-2	Assembly of fan and cover parts .....	56
Figure 4-3	Fan cable disconnection ( <i>left</i> ) and final placement ( <i>right</i> ) .....	56
Figure 5-1	Acquisition connectors .....	64
Figure 6-1	Scanner encoder LEMO connector (contact view) .....	70
Figure 6-2	Alarm and I/O LEMO connector (contact view) .....	72
Figure 7-1	Ethernet Properties dialog box .....	74
Figure 7-2	Jumbo Packet setting .....	75
Figure 7-3	Speed & Duplex setting .....	76
Figure 7-4	Configuration in WeldSight .....	77
Figure 7-5	Connection status — Ready .....	78
Figure 7-6	Connection status — Connected .....	79



---

## List of Tables

---

Table 1	Main controls for OmniScan X3 flaw detector .....	28
Table 2	Power indicator light statuses .....	29
Table 3	Acquisition indicator light statuses .....	30
Table 4	Troubleshooting guide .....	58
Table 5	OmniScan X3 general specifications .....	61
Table 6	Acoustic specifications—UT channel using UT connector .....	64
Table 7	Acoustic specifications—PA channel .....	65
Table 8	Acquisition specifications .....	67
Table 9	Data specifications .....	67
Table 10	Pinout for the scanner encoder LEMO connector .....	70
Table 11	Pinout for the Alarm and I/O connector .....	72
Table 12	Optional Items (sold separately on demand) .....	81
Table 13	Compatible accessories .....	82
Table 14	Spare parts .....	83

