



# CFU03/CFU05/CFU-PWZ Couplant Feed Unit User's Manual

DMTA048-01EN— Revision D

November 2022

EVIDENT CANADA, INC.  
3415, rue Pierre-Ardouin, Quebec (Quebec) G1P 0B3 Canada

© 2022 by Evident. All rights reserved. No part of this publication may be reproduced, translated, or distributed without the express written permission of Evident.

This document was prepared with particular attention to usage to ensure the accuracy of the information contained therein, and corresponds to the version of the product manufactured prior to the date appearing on the title page. There could, however, be some differences between the manual and the product if the product was modified thereafter.

The information contained in this document is subject to change without notice.

Part number: DMTA048-01EN  
Revision D  
November 2022

Printed in Canada

All brands are trademarks or registered trademarks of their respective owners and third party entities.

---

---

# Table of Contents

---

<b>Labels and Symbols .....</b>	<b>1</b>
<b>Important Information – Please Read Before Use .....</b>	<b>5</b>
Intended Use .....	5
Instruction Manual .....	5
Equipment Compatibility .....	6
Repair and Modification .....	6
Safety Symbols .....	6
Safety Signal Words .....	7
Note Signal Words .....	8
Electrical Safety .....	8
Equipment Disposal .....	10
WEEE Directive .....	10
Warranty Information .....	10
Technical Support .....	11
<b>Introduction .....</b>	<b>13</b>
<b>1. Product Description .....</b>	<b>15</b>
1.1 Package Contents .....	15
1.2 Definition of the Sides of the Water Pump Case .....	16
1.3 Characteristics .....	18
1.3.1 Right and Left Side Views .....	18
1.3.2 Water Flow .....	21
1.3.3 Water Suction Capability on CFU05 .....	21
1.3.4 Remote Control Capability on CFU-PWZ .....	21
<b>2. Connections .....</b>	<b>23</b>
2.1 Types of Connections on the Water Pumps .....	24

2.2	Power Connection .....	26
2.2.1	Connecting the Power Supply to the CFU Water Pumps .....	26
2.2.2	Connecting the CFU-PWZ Power Supply and the Remote Control .....	27
2.3	Water Connections .....	29
2.3.1	Connecting the Water Supply Tube .....	29
2.3.2	Connecting the Water Outlet Tube on CFU03 and CFU05 .....	30
2.3.3	Connecting the Water Outlet Tube on CFU-PWZ .....	32
2.4	Vacuum Suction System (CFU05) .....	33
2.4.1	Air Supply .....	33
2.4.2	Water Discharge .....	34
2.4.3	Water Suction Connection .....	35
<b>3.</b>	<b>Operation .....</b>	<b>39</b>
3.1	Operating the CFU03 .....	39
3.2	Operating the CFU05 .....	40
3.3	Operating the CFU-PWZ .....	40
<b>4.</b>	<b>Maintenance and Troubleshooting .....</b>	<b>43</b>
4.1	Maintaining the Water Inlet Tube's Suction Filter .....	43
4.2	Draining the Water Pump .....	43
4.3	Cleaning the Water Pump .....	44
4.4	Unfreezing the Water Pump .....	44
4.5	Spare Parts .....	45
4.6	Troubleshooting .....	46
<b>5.</b>	<b>Specifications .....</b>	<b>53</b>
5.1	CFU03 Specifications .....	53
5.2	CFU05 Specifications .....	54
5.3	CFU-PWZ Specifications .....	57
	<b>List of Figures .....</b>	<b>61</b>
	<b>List of Tables .....</b>	<b>63</b>

## Labels and Symbols

Safety-related labels and symbols are attached to the equipment at the locations shown in Figure i-1 on page 1 (CFU-PWZ is shown, however the rating label for the CFU03 and CFU05 are at the same location). If any or all of the labels or symbols are missing or illegible, please contact Evident.

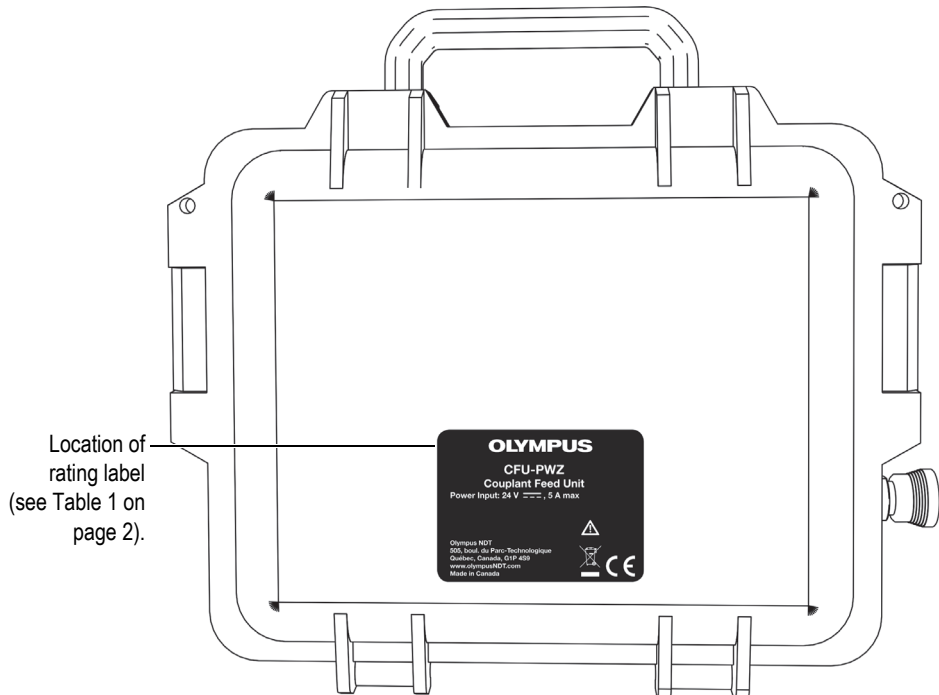





**Figure i-1 Rating label location**

Table 1 Content of the rating labels

<p><b>OLYMPUS</b></p> <p><b>CFU03</b></p> <p><b>Couplant Feed Unit</b></p> <p>Power Input: 24 V  , 3.5 A max</p> <p>Olympus NDT 505, boul. du Parc-Technologique Québec, Canada, G1P 4S9 www.olympusNDT.com Made in Canada</p> <p>  </p>
<p><b>OLYMPUS</b></p> <p><b>CFU05</b></p> <p><b>Couplant Feed Unit</b></p> <p>Power Input: 24 V  , 3.5 A max</p> <p>Olympus NDT 505, boul. du Parc-Technologique Québec, Canada, G1P 4S9 www.olympusNDT.com Made in Canada</p> <p>  </p>
<p><b>OLYMPUS</b></p> <p><b>CFU-PWZ</b></p> <p><b>Couplant Feed Unit</b></p> <p>Power Input: 24 V  , 5 A max</p> <p>Olympus NDT 505, boul. du Parc-Technologique Québec, Canada, G1P 4S9 www.olympusNDT.com Made in Canada</p> <p>  </p>

**Table 1 Content of the rating labels (continued)**

Content	
	The direct current symbol.
	The warning symbol indicates that the user must read the user's manual before using the product.
	The WEEE symbol indicates that the product must not be disposed of as unsorted municipal waste, but should be collected separately.
	This device complies with the requirements of directive 2014/30/EU concerning electromagnetic compatibility, directive 2014/35/EU concerning low voltage, and directive 2015/863 which amends 2011/65/EU concerning restriction of hazardous substances (RoHS). The CE marking is a declaration that this product conforms to all the applicable directives of the European Community.
	This device complies with the requirements of the Electromagnetic Compatibility Regulations 2016, the Electrical Equipment (Safety) Regulations 2016, and the Restriction of the Use of Certain Hazardous Substances in Electrical and Electronic Equipment Regulations 2012. The UKCA marking indicates compliance with the above regulations.





---

## Important Information — Please Read Before Use

---

### Intended Use

The Couplant Feed Unit (CFU) Water Pumps are designed as an accessory to help perform nondestructive inspections. They are used to supply couplant (water) to probe wedges during ultrasonic inspections.



#### **DANGER**

Do not use the CFU Water Pumps for any purpose other than their intended use. They must never be used as an accessory to inspect or examine human or animal body parts.

---

### Instruction Manual

This instruction manual contains essential information on how to use this Evident product safely and effectively. Before using this product, thoroughly review this instruction manual. Use the product as instructed.

Keep this instruction manual in a safe, accessible location.

## Equipment Compatibility

The CFU03 and CFU05 Water Pumps are compatible with the Evident scanners and wedges.

The CFU-PWZ Water Pump is compatible with the Evident PipeWIZARD.

---



### CAUTION

Using incompatible equipment could cause malfunction and/or equipment damage.

---

## Repair and Modification

The CFU Water Pumps do not contain any user-serviceable parts. Opening the equipment will void the warranty.

---



### CAUTION

In order to prevent human injury and/or equipment damage, do not disassemble, modify, or attempt to repair the equipment.

---

## Safety Symbols

The following safety symbol might appear on the equipment and in the instruction manual:



General warning symbol:

This symbol is used to alert the user to potential hazards. All safety messages that follow this symbol shall be obeyed to avoid possible harm.

---



High voltage warning symbol

This symbol is used to alert the user to potential electric shock hazards greater than 1000 volts. All safety messages that follow this symbol shall be obeyed to avoid possible harm.

## Safety Signal Words

The following safety symbols might appear in the documentation of the equipment:



**DANGER**

The DANGER signal word indicates an imminently hazardous situation. It calls attention to a procedure, practice, or the like, which, if not correctly performed or adhered to, could result in death or serious personal injury. Do not proceed beyond a DANGER signal word until the indicated conditions are fully understood and met.



**WARNING**

The WARNING signal word indicates a potentially hazardous situation. It calls attention to a procedure, practice, or the like, which, if not correctly performed or adhered to, could result in death or serious personal injury. Do not proceed beyond a WARNING signal word until the indicated conditions are fully understood and met.



**CAUTION**

The CAUTION signal word indicates a potentially hazardous situation. It calls attention to an operating procedure, practice, or the like, which, if not correctly performed or adhered to, could result in minor or moderate personal injury, material damage, particularly to the product, destruction of part or all of the product, or loss of data. Do not proceed beyond a CAUTION signal word until the indicated conditions are fully understood and met.

## Note Signal Words

The following safety symbols could appear in the documentation of the equipment:

**IMPORTANT**

The IMPORTANT signal word calls attention to a note that provides important information, or information essential to the completion of a task.

**NOTE**

The NOTE signal word calls attention to an operating procedure, practice, or the like, which requires special attention. A note also denotes related parenthetical information that is useful, but not imperative.

**TIP**

The TIP signal word calls attention to a type of note that helps you apply the techniques and procedures described in the manual to your specific needs, or provides hints on how to effectively use the capabilities of the product.

## Electrical Safety

This equipment is equipment of Class 1 and installation category II. Before turning on the equipment, verify that the correct safety precautions have been taken (see the following warnings). In addition, note the external markings on the equipment, which are described under Safety Symbols.



### General Warnings

- Carefully read the instructions contained in this instruction manual prior to turning on the equipment.
- Keep this instruction manual in a safe place for further reference.
- Follow the installation and operation procedures.

- It is imperative to respect the safety warnings on the equipment and in this instruction manual.
  - If the equipment is used in a manner not specified by the manufacturer, the protection provided by the equipment could be impaired.
  - The power supply and the CFU-PWZ remote control are intended for indoor use. Therefore, do not use them outdoors.
  - Do not install substitute parts or perform any unauthorized modification to the equipment. Only Evident parts must be used.
  - There are no user-serviceable parts inside the equipment. Service instructions, when applicable, are for trained service personnel. To avoid the risk of electric shock, do not perform any work on the equipment unless qualified to do so. For any problem or question regarding this equipment, contact Evident or an authorized Evident representative.
- 



**CAUTION**

Do not cut the tie wrap that seals the pump case. The interior contains parts that can become hot enough to burn skin if touched. There is a risk of a high-pressure jet of water hitting your eyes. Unsealing the pump case will also void the warranty.

---



**CAUTION**

Always wear metal-cap boots while carrying or using the CFU Water Pumps.

---



**WARNING**



The equipment must only be connected to a power source corresponding to the type indicated on the rating plate. Therefore, only use the power supply that is sold with the equipment.

---



### CAUTION

Use only the AC power cord supplied with the pump. Do not use this AC power cord with other products.

---



### DANGER

Use this equipment to pump only water and no other liquid or substance. Do not use with flammable liquids.

---

## Equipment Disposal

Before disposing of the CFU Water Pumps, check your local laws, rules, and regulations, and follow them accordingly.

## WEEE Directive



In accordance with European Directive 2012/19/EU on Waste Electrical and Electronic Equipment (WEEE), this symbol indicates that the product must not be disposed of as unsorted municipal waste, but should be collected separately. Refer to your local Evident distributor for return and/or collection systems available in your country.



## Warranty Information

Evident guarantees your Evident product to be free from defects in materials and workmanship for a specific period, and in accordance with conditions specified in the *Evident Terms and Conditions* available at <https://www.olympus-ims.com/en/terms/>.

The Evident warranty only covers equipment that has been used in a proper manner, as described in this instruction manual, and that has not been subjected to excessive abuse, attempted unauthorized repair, or modification.

Inspect materials thoroughly on receipt for evidence of external or internal damage that might have occurred during shipment. Immediately notify the carrier making the delivery of any damage, because the carrier is normally liable for damage during shipment. Retain packing materials, waybills, and other shipping documentation needed in order to file a damage claim. After notifying the carrier, contact Evident for assistance with the damage claim and equipment replacement, if necessary.

This instruction manual explains the proper operation of your Evident product. The information contained herein is intended solely as a teaching aid, and shall not be used in any particular application without independent testing and/or verification by the operator or the supervisor. Such independent verification of procedures becomes increasingly important as the criticality of the application increases. For this reason, Evident makes no warranty, expressed or implied, that the techniques, examples, or procedures described herein are consistent with industry standards, nor that they meet the requirements of any particular application.

Evident reserves the right to modify any product without incurring the responsibility for modifying previously manufactured products.

## **Technical Support**

Evident is firmly committed to providing the highest level of customer service and product support. If you experience any difficulties when using our product, or if it fails to operate as described in the documentation, first consult the user's manual, and then, if you are still in need of assistance, contact our After-Sales Service. To locate the nearest service center, visit the Service Centers page on the Evident Scientific Web site.





## Introduction

---

This manual provides instructions and technical specifications for the CFU03, CFU05, and CFU-PWZ portable electric pumps. These units are equipped with a diaphragm pump to avoid any pump priming issues and a bypass to ensure a constant flow.

Additional features apply to one or two of the specific pumps:

- CFU03 and CFU05: These pumps have a valve to control the outlet flow.
- CFU03 and CFU05: The water OUTLET for these pumps features a plastic quick-coupling connection for 8 mm tubes.
- CFU05: This pump features water suction capability to reduce water loss when used with water delay line wedges.
- CFU-PWZ: The water OUTLET for this pump features a metallic quick-coupling connection that is used specifically for the PipeWIZARD (PWZ).
- CFU-PWZ: This pump also features a remote control box and cable to start and stop the water pump at a distance of up to 10 m.

This manual is organized into sections that allow a progressive understanding of the CFU Water Pumps' features and operation. Each section, however, is complete in itself. This manual is therefore a useful reference.



# 1. Product Description

## 1.1 Package Contents

Package contents differ depending on the product: CFU03, CFU05, or CFU-PWZ (Table 2 on page 15).

**Table 2 Package contents**

Package Component	Part Number	Unit Quantity	CFU03	CFU05	CFU-PWZ
CFU03 Case	ABIX0948	1	√		
CFU05 Case	ABIX0949	1		√	
CFU-PWZ Case	ABIX0950	1			√
Inlet Feed Tube	ABIX0632	1	√	√	√
Outlet / Suction Water Tube	ABIX0633	CFU03: 1 CFU05: 2	√	√	
Outlet Water Tube	AFIX004	1			√
Vacuum Outlet Tube	ABIX0634	1		√	

**Table 2 Package contents (continued)**

Package Component	Part Number	Unit Quantity	CFU03	CFU05	CFU-PWZ
Filter 3/8 NPT-F 60 Mesh	25PO0622	1	√	√	√
Remote Control On/Off CFU-PWZ	ADIX1768	1			√
Power Supply 24 V 150 W	EKIX0162	1	√	√	√
User's Manual	DMTA048-01EN	1	√	√	√

## 1.2 Definition of the Sides of the Water Pump Case

In this manual, some diagrams and procedures indicate the location of connectors on a specific water pump. For this manual, the sides of the water pump case are defined as shown on Figure 1-1 on page 17 and Figure 1-2 on page 17.

---

### NOTE

This section displays the CFU-PWZ water pump, however the information is valid for the CFU03 and CFU05.

---

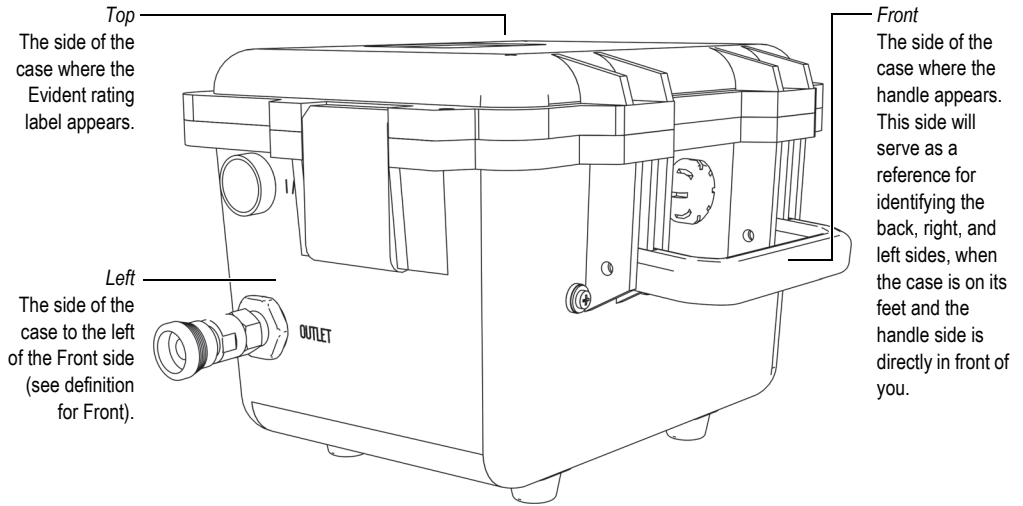

**Figure 1-1 Top, left, and front sides of the water pump case**

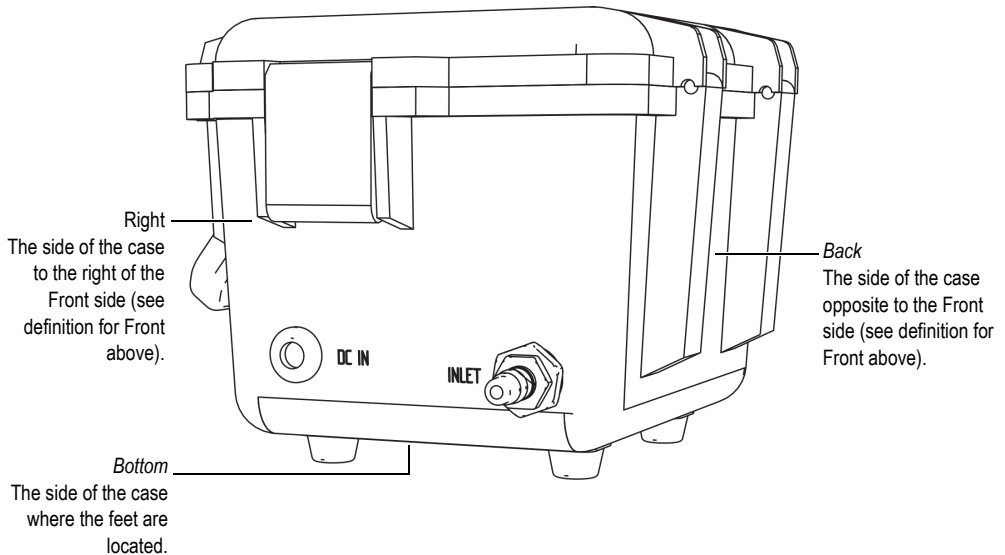

**Figure 1-2 Right, bottom, and back sides of the water pump case**

## 1.3 Characteristics

The main characteristics of the water pumps are given in this section. For detailed specifications, see chapter 5 “Specifications” on page 53.

### 1.3.1 Right and Left Side Views

The CFU03’s Right side view is shown in Figure 1-3 on page 18.

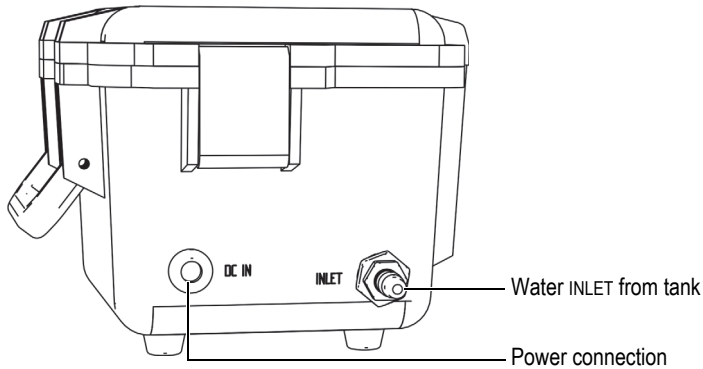

**Figure 1-3 Right side of CFU03**

The CFU03’s Left side view is shown in Figure 1-4 on page 18.

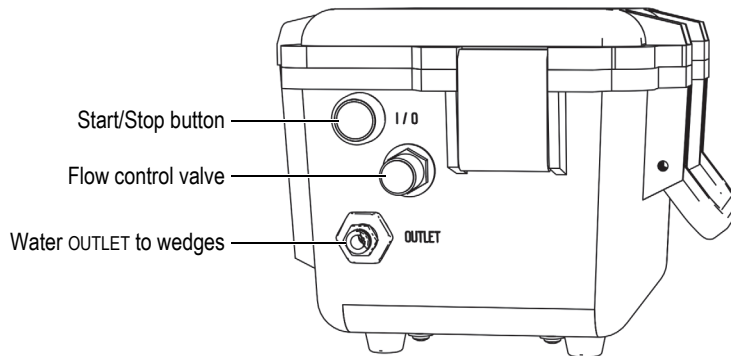

**Figure 1-4 Left side of CFU03**

The CFU05's Right side view is shown in Figure 1-5 on page 19.

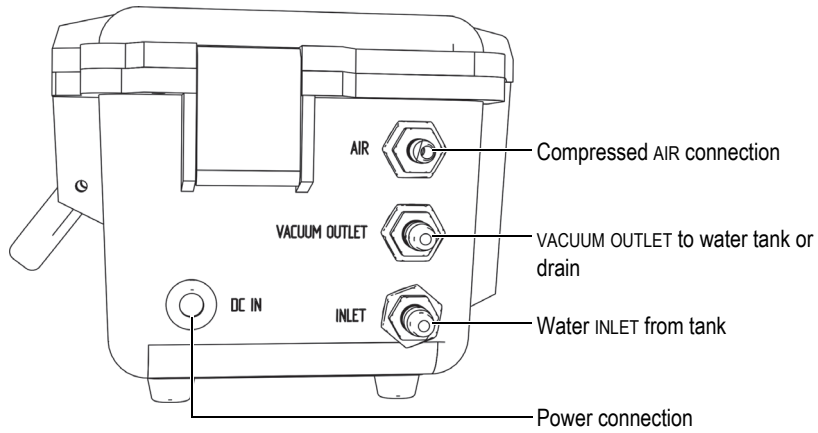

**Figure 1-5 Right side of CFU05**

The CFU05's Left side view is shown in Figure 1-6 on page 19.

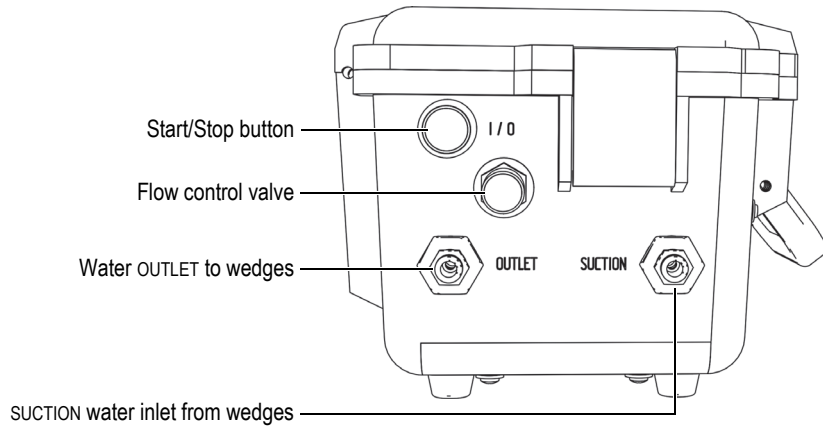

**Figure 1-6 Left side of CFU05**

The CFU-PWZ's Right side view is shown in Figure 1-7 on page 20.

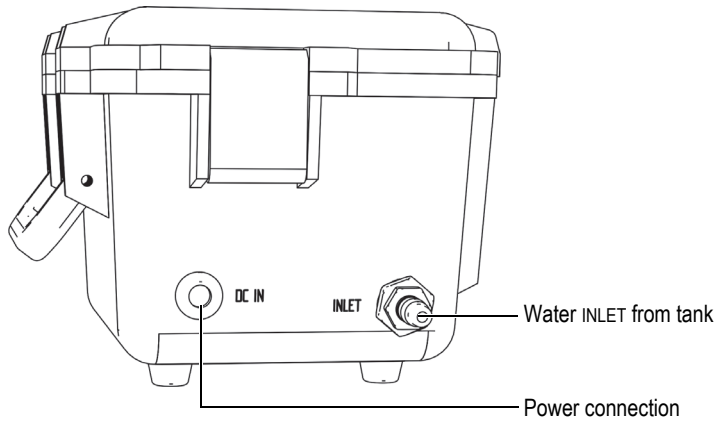

**Figure 1-7 Right side of CFU-PWZ**

The CFU-PWZ's Left side view is shown in Figure 1-8 on page 20.

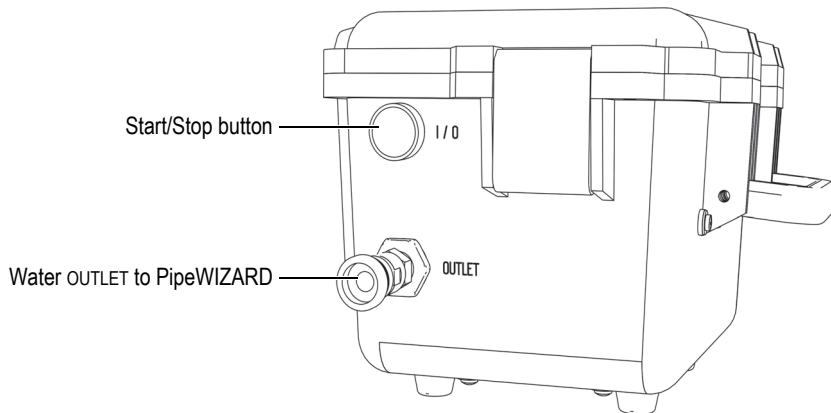

**Figure 1-8 Left side of CFU-PWZ**



### **1.3.2 Water Flow**

The diaphragm pumps have the following flow capacity:

- CFU03 and CFU05: 3.78 L/min (1 GPM)
- CFU-PWZ: 6 L/min (1.6 GPM)

The units operate on both 120 VAC and 240 VAC. The pump inlet tube is equipped with a water suction filter, an in-line algae filter, and a check valve to ensure that the tube is always filled.

### **1.3.3 Water Suction Capability on CFU05**

Only the CFU05 is capable of water suction, using an external compressed air supply to generate a Venturi vacuum.

### **1.3.4 Remote Control Capability on CFU-PWZ**

When the CFU-PWZ is used with the remote control, the power supply will be connected to the remote control box, and it will be the remote control cable that will be connected to the CFU-PWZ's power connection. In order to use the remote control's start/stop button to start or stop the water pump, the CFU-PWZ's start/stop button must remain in the start position (pressed).



---

## 2. Connections

---

In this section, all of the connections are described both in diagrams and procedures.



### CAUTION

Pay special attention to, and comply with the following instruction, in step 1 of many connection and disconnection procedures: “Ensure that the pump is turned off.” Not respecting this instruction could result in a bad power connection in the long term due to sparks. Figure 2-1 on page 23 illustrates the difference between the Off position and the On position. In the On position, the Start/Stop (I/O) button is pressed down.

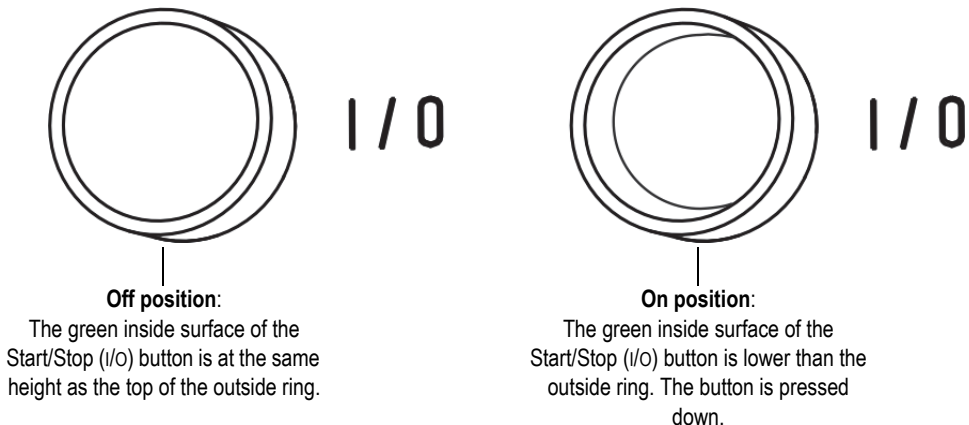

**Figure 2-1 Position of the Start/Stop button when the pump is turned off**

## 2.1 Types of Connections on the Water Pumps

There are three common connections for the CFU03 and CFU05 Water Pumps. These are:

- the power connection
- the water INLET from the water tank to the water pump
- the water OUTLET to the wedges

---

<b>NOTE</b>
-------------

The CFU-PWZ also has a water OUTLET connection, but it is not the same type of connection as the CFU03 and CFU05.

---

There are three additional connections for the CFU05 water suction. These are:

- the compressed AIR for vacuum generation
- the SUCTION water inlet from the wedges
- the VACUUM OUTLET to a water tank or drain

Apart from the power connection, the CFU Water Pumps feature three types of connections:

- The color-coded metallic quick-coupling connections with male connectors on the water pump. These connectors are shown on the CFU05 in Figure 2-2 on page 25, since all connectors of this type appear on that water pump.
- The plastic quick-coupling connections. These connectors are shown on the CFU05 in Figure 2-3 on page 25, since all connectors of this type appear on that water pump.
- The metallic quick-coupling connection with a female connector on the water pump. This connector is only used on the CFU-PWZ's water OUTLET (see Figure 2-4 on page 26).

Each type of connection has a different procedure for connecting and disconnecting. Each connector and its connection procedures will be documented in a separate section.

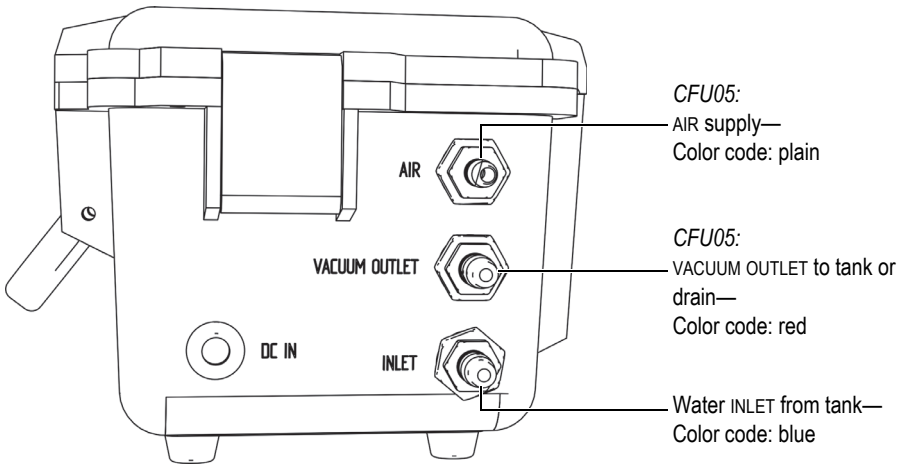

**Figure 2-2 Color-coded connections with male connectors on pump**

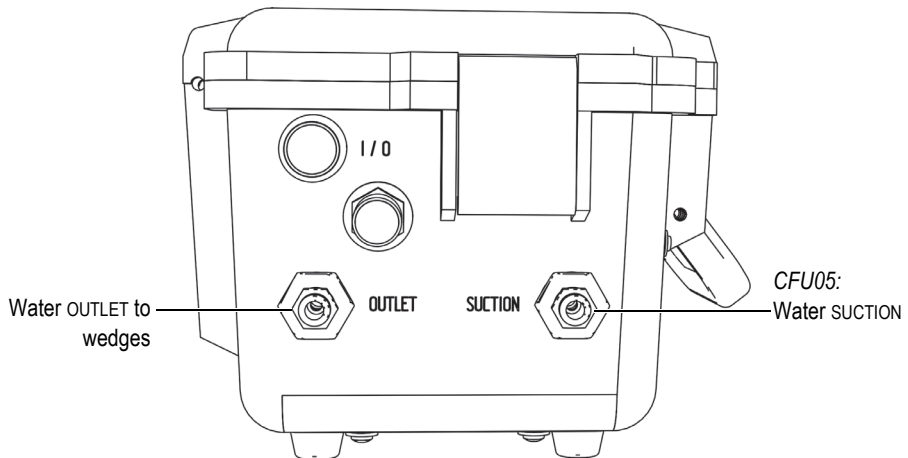

**Figure 2-3 Plastic quick-coupling connections**

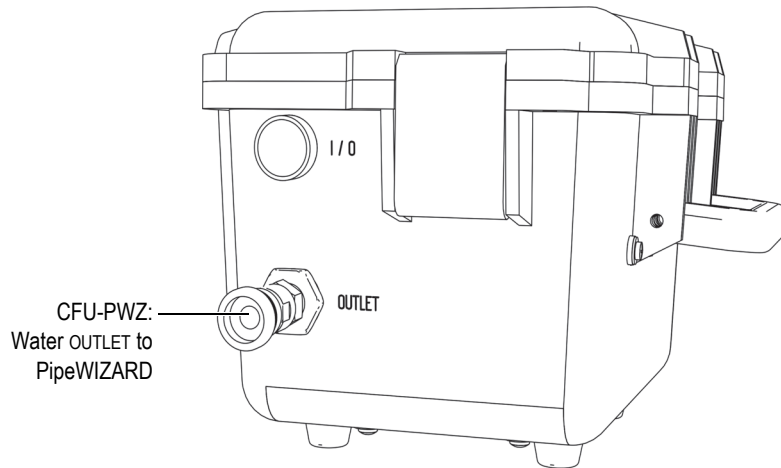

**Figure 2-4 Metallic connection with female connector on pump**

## **2.2 Power Connection**

The voltage requirement for the CFU Water Pumps is 100 VAC to 240 VAC. You must ensure that your power feed meets this requirement. The power cord supplied with the power supply varies, depending on your location.

### **2.2.1 Connecting the Power Supply to the CFU Water Pumps**

This section documents the standard power connection procedures. If you want to use the CFU-PWZ with the remote control, see section 2.2.2 on page 27.

#### **To connect the power supply to the water pump**

1. Ensure that the pump is turned off.
2. Align the pins of the power supply's LEMO connector with the holes of the CFU power connection's DC IN receptacle (Figure 2-5 on page 27).
3. Insert the LEMO connector into the DC IN receptacle.
4. Insert the power cable in the power supply unit's AC In connection and the power plug in an AC power outlet (wall).
5. Ensure that the pump is on its feet. Do not position the equipment so that it is difficult to disconnect the power supply LEMO connector in case of emergency.

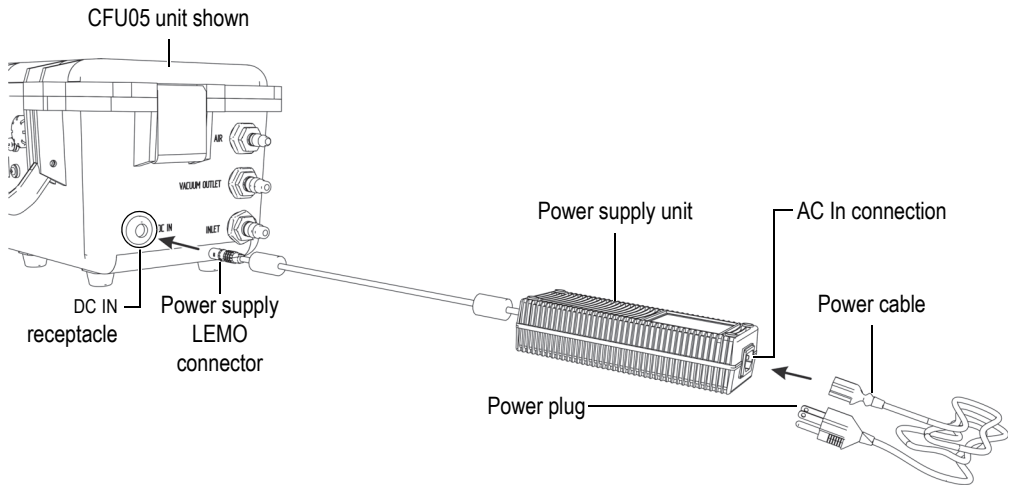

**Figure 2-5 Connecting the power supply to a pump**

### To disconnect the power supply from the water pump

1. Ensure that the pump is turned off.
2. Hold the metallic portion of the power supply connector (Figure 2-5 on page 27).
3. Pull out the connector from the DC IN receptacle.
4. Disconnect the power plug from the AC power outlet (wall).

## 2.2.2 Connecting the CFU-PWZ Power Supply and the Remote Control

This section documents the CFU-PWZ specific power connection procedures when you want to use the remote control.

### To connect the power supply and the remote control to the CFU-PWZ

1. Ensure that the pump is turned off.
2. Align the pins of the remote control LEMO connector with the holes of the CFU-PWZ power connection's DC IN receptacle (Figure 2-6 on page 28).
3. Insert the remote control LEMO connector into the pump's DC IN receptacle.

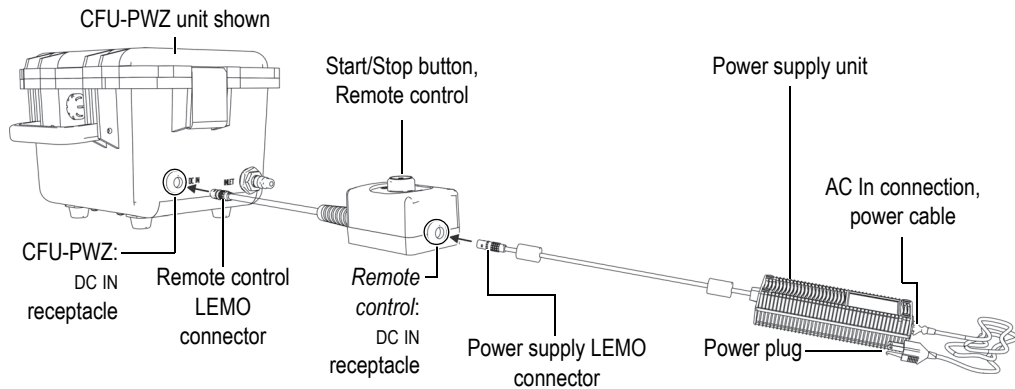

**Figure 2-6 Connecting the remote control to a pump**

4. Align the pins of the power supply LEMO connector with the holes of the remote control's DC IN receptacle (Figure 2-6 on page 28).
5. Insert the power supply LEMO connector into the remote control's DC IN receptacle.
6. Insert the power cable in the power supply unit (see Figure 2-5 on page 27 and Figure 2-6 on page 28) and the power plug in an AC power outlet (wall).

### **To disconnect the power supply and the remote control from the CFU-PWZ**

1. Ensure that the pump is turned off.
2. On the pump, hold the metallic portion of the remote control's power connector (Figure 2-6 on page 28).
3. Pull out the remote control connector from the pump's power receptacle.
4. On the remote control, hold the box and the metallic portion of the power supply's connector (Figure 2-6 on page 28).
5. Pull out the power supply connector from the remote control's DC IN receptacle.
6. Disconnect the power plug from the AC power outlet (wall).



## 2.3 Water Connections

The water supply INLET connection uses a color-coded metallic quick-coupling mechanism. The water OUTLET connection uses a plastic quick-coupling mechanism.

### 2.3.1 Connecting the Water Supply Tube

The water-supply tube coming from the water tank connects to the water INLET connection. The water supply tube has a blue color-coded metallic quick coupling, and a filter inlet (see Figure 2-7 on page 29).

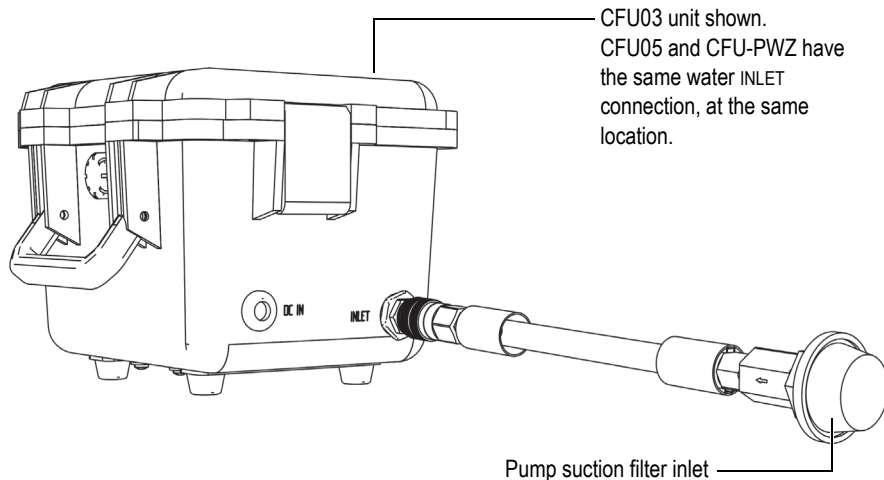

**Figure 2-7 Water supply tube**

#### To connect the water supply tube to the pump (CFU03, CFU05, and CFU-PWZ)

1. Ensure that the pump is turned off.
2. Select the tube with the blue color-coded metallic quick-coupling mechanism.
3. Push the blue female metallic quick coupling in the blue male INLET connector until it snaps into place (Figure 2-8 on page 30); in this position, the connector is locked.

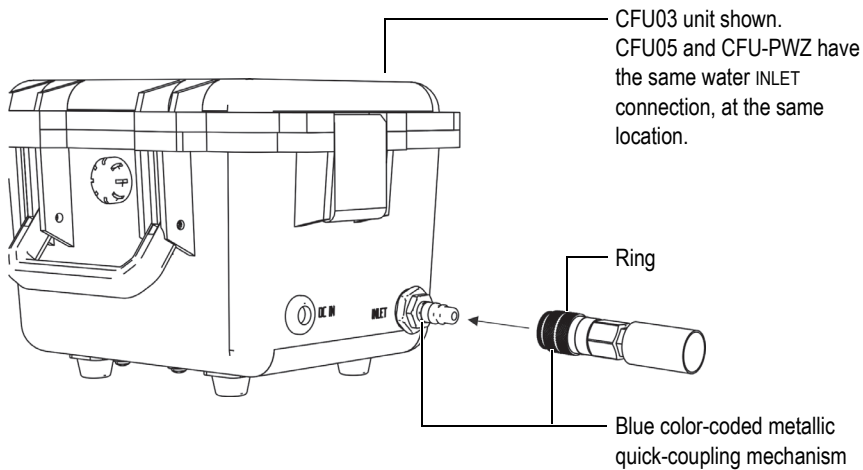

**Figure 2-8 Water supply INLET connection**

### **To disconnect the water supply tube from the pump (CFU03, CFU05, and CFU-PWZ)**

1. Ensure that the pump is turned off.
2. Pull back the blue ring of the coupling to release the tube's male connector (Figure 2-8 on page 30).
3. Pull out the tube.

### **2.3.2 Connecting the Water Outlet Tube on CFU03 and CFU05**

The water outlet tube connects to the CFU03/CFU05 pump's water OUTLET connector. This connection uses a plastic quick-coupling mechanism.

#### **To connect the water outlet (CFU03 and CFU05)**

1. Ensure that the pump is turned off.
2. Select the water tube that will feed the probe wedges.
3. Insert the tube into the OUTLET connector (see Figure 2-9 on page 31).
4. Push the tube into the receptacle to trigger the plastic quick-coupling mechanism.

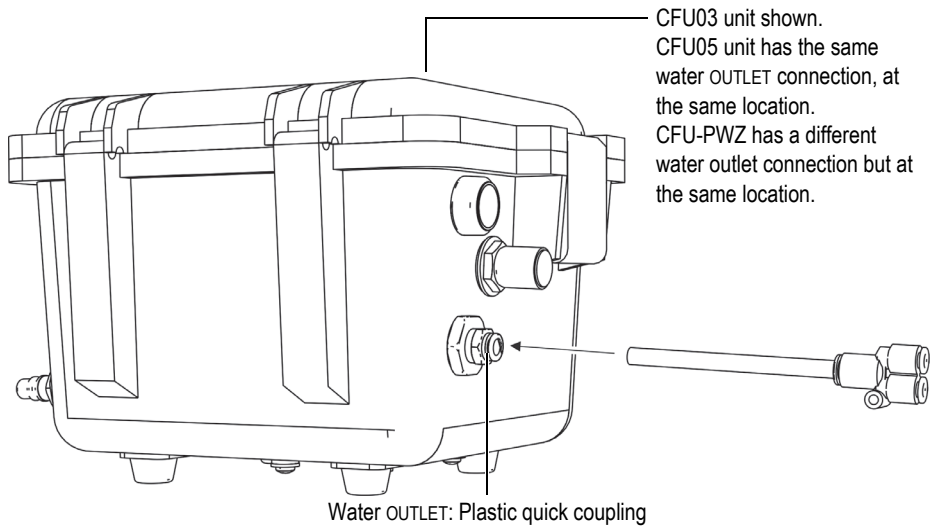

**Figure 2-9 Water OUTLET connection**

**To disconnect the water outlet (CFU03 and CFU05)**

1. Grab the tube with one hand.
2. Push on the outer blue plastic ring of the connector to release the tube (see Figure 2-10 on page 31).
3. Pull out the tube.

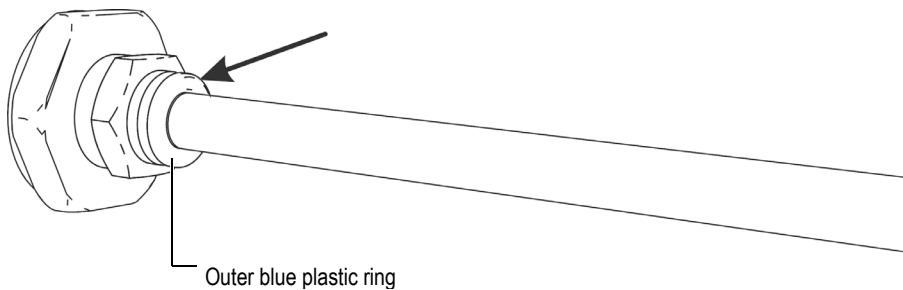

**Figure 2-10 Disconnecting the water outlet tube**

### 2.3.3 Connecting the Water Outlet Tube on CFU-PWZ

The water outlet tube connects to the CFU-PWZ pump's water OUTLET connector.

#### To connect the water outlet tube (CFU-PWZ)

1. Ensure that the pump is turned off.
2. Select the water tube that has two male connectors with red color coding.
3. Push one of the male connectors into the pump's female water OUTLET connection until the metal coupling snaps into place (see Figure 2-11 on page 32).

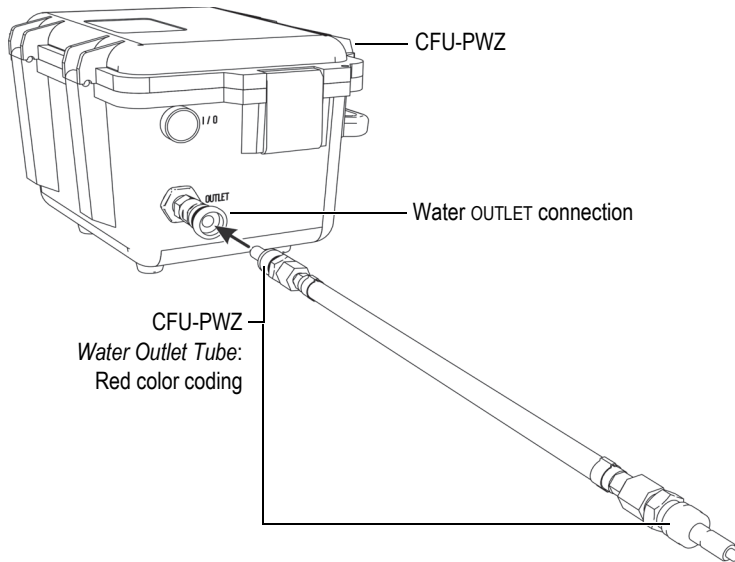

Figure 2-11 CFU-PWZ water OUTLET connection

#### To disconnect the water outlet tube (CFU-PWZ)

1. Ensure that the pump is turned off.
2. Pull the metal coupling until the male connector snaps out of place.
3. Pull out the tube.

## 2.4 Vacuum Suction System (CFU05)

This section will document the three connections that are specific to the CFU05 pump.

### 2.4.1 Air Supply

The water suction system on the CFU05 needs an adequate supply of compressed air to generate the required vacuum. The vacuum suction's air supply is connected to the AIR connector. This AIR supply connection uses a metallic quick-coupling mechanism similar to the one used by the water supply INLET connection (see Figure 2-12 on page 33).

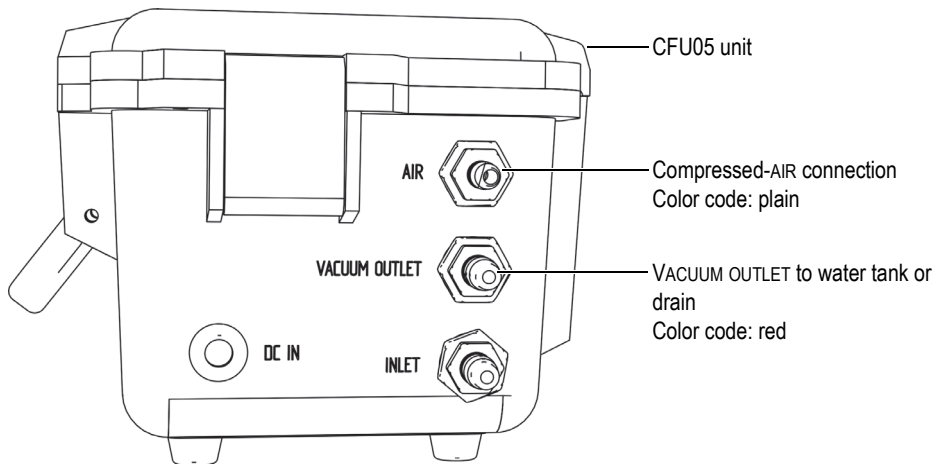
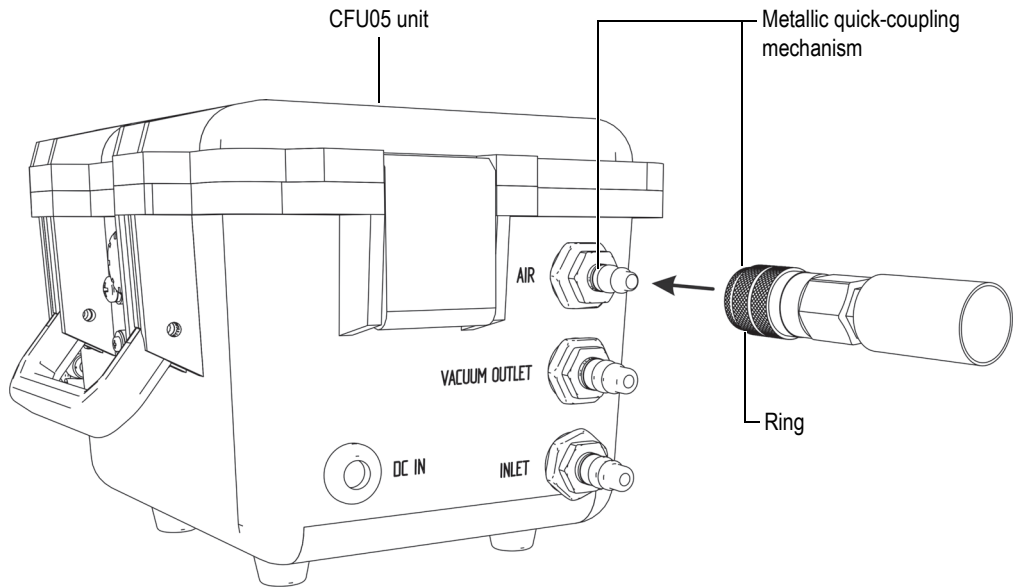

**Figure 2-12 CFU05—Color-coded connections of the vacuum system**

The air supply hose is not provided with the CFU05.

#### To connect the air-supply hose to the pump (CFU05)

1. Select the air-supply hose with the metallic quick-coupling mechanism (this hose is not part of the CFU05 package).
2. Push the female metallic quick coupling in the plain male AIR connector until it snaps into place; in this position, the connector is locked (see Figure 2-13 on page 34).



**Figure 2-13 Compressed AIR connection**

### To disconnect the air-supply hose from the pump (CFU05)

1. Pull back the ring of the coupling to release the hose's male connector (see Figure 2-13 on page 34).
2. Pull out the hose.

## 2.4.2 Water Discharge

The vacuum suction's water discharge hose is connected to the VACUUM OUTLET connection. This connection uses a red color-coded metallic quick-coupling mechanism (see Figure 2-12 on page 33).

### To connect the water discharge hose to the pump (CFU05)

1. Ensure that the pump is turned off.
2. Select the hose with the red color-coded metallic quick-coupling mechanism (see Figure 2-14 on page 35).

3. Push the red female metallic quick coupling in the red male VACUUM OUTLET connector until it snaps into place; in this position, the connector is locked.

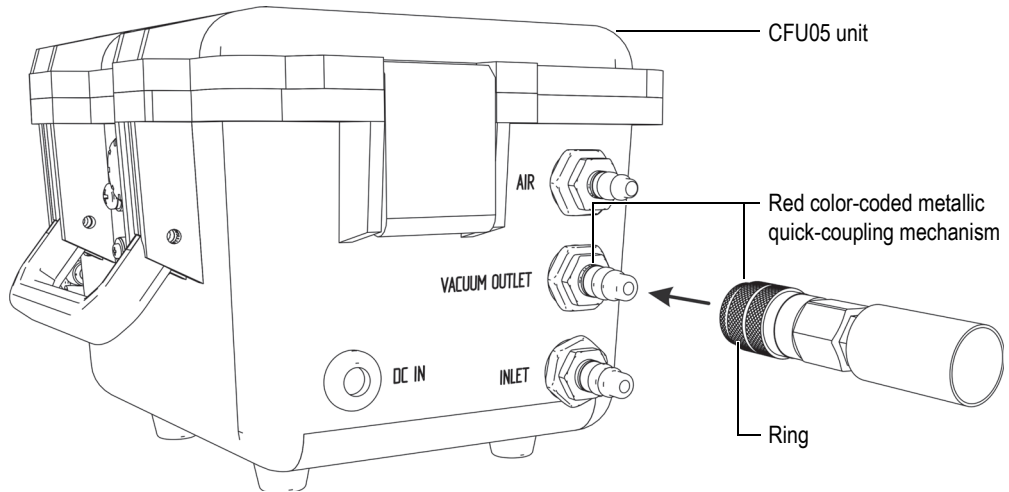

**Figure 2-14 VACUUM OUTLET connection**

### To disconnect the water discharge hose from the pump (CFU05)

1. Pull back the red ring of the coupling to release the hose's male connector (see Figure 2-14 on page 35).
2. Pull out the hose.

### 2.4.3 Water Suction Connection

The CFU05 uses suction to remove excess water from the wedges. The recovered water enters through the SUCTION connection (see Figure 2-15 on page 36).

The water SUCTION connection uses a plastic quick-coupling mechanism identical to the one used by the CFU03/CFU05 water supply OUTLET connection.

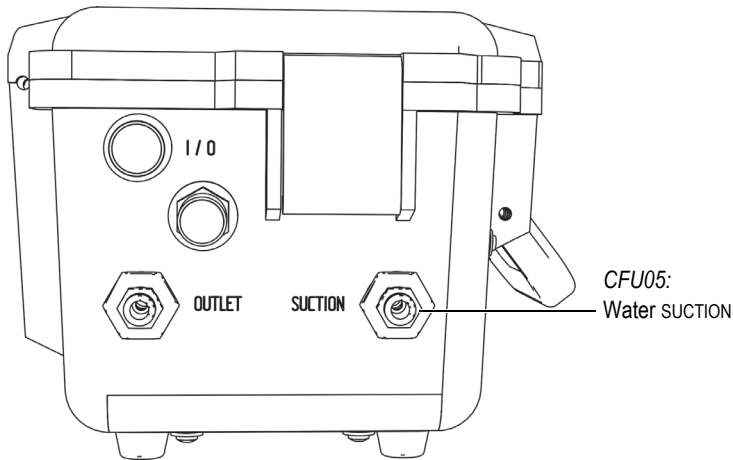

**Figure 2-15 CFU05—Water SUCTION connector**

**To connect the water-suction tube**

1. Insert the water suction tube into the water SUCTION connection (see Figure 2-16 on page 36).
2. Push the tube into the receptacle to trigger the plastic quick-coupling mechanism.

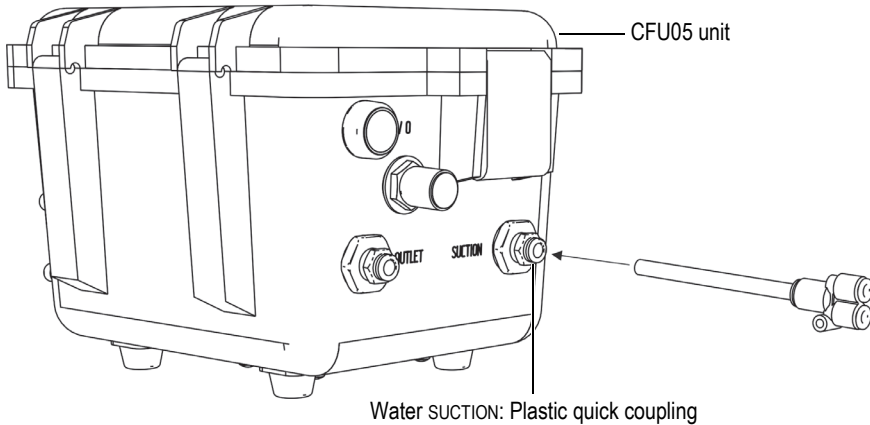
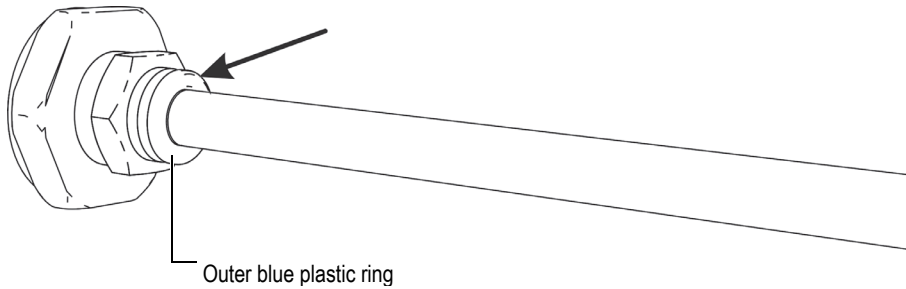

**Figure 2-16 CFU05—Water SUCTION connection**



### To disconnect the water suction tube

1. Grab the tube with one hand.
2. Push on the outer blue plastic ring of the connector to release the tube (see Figure 2-17 on page 37).
3. Pull out the tube.



**Figure 2-17 CFU05—Disconnecting the water suction tube**



---

## 3. Operation

---

This section presents the usual procedures to setup, operate during inspection, and shut down the CFU Water Pumps.

### 3.1 Operating the CFU03

This section explains the operating procedure of the CFU03 water pump.

#### To operate the CFU03

1. Ensure that all connections on the pump are correctly made. See chapter 2 “Connections” on page 23.
2. Ensure that all connections on the scanner and wedges are correctly made.
3. Ensure that the filter end of the pump’s inlet tube is clean and in good working condition. For details, see section 4.1 “Maintaining the Water Inlet Tube’s Suction Filter” on page 43.
4. Place the filter end of the pump’s inlet tube below the water level in the water tank.
5. Start the pump using the green start/stop button.
6. Adjust the water flow as required, using the outlet’s flow control valve.
7. When you have finished your inspection and the unit is no longer required, turn off the pump using the green start/stop button, disconnect the power supply, and then remove the power plug from the AC power outlet.
8. Drain the water pump. See section 4.2 “Draining the Water Pump” on page 43.

## 3.2 Operating the CFU05

This section explains the operating procedure of the CFU05 water pump.

### To operate the CFU05

1. Ensure that all connections on the pump are correctly made. See chapter 2 “Connections” on page 23.
2. Ensure that all connections on the scanner and wedges are correctly made.
3. Ensure that the filter end of the pump’s inlet tube is clean and in good working condition. See section 4.1 “Maintaining the Water Inlet Tube’s Suction Filter” on page 43.
4. Place the filter end of the pump’s inlet tube below the water level in the water tank.
5. Place the end of the SUCTION’s water-outlet tube into the water tank.
6. Start the pump using the green start/stop button.
7. Adjust the water flow as required, using the outlet’s flow control valve.
8. Turn on the air supply and adjust the air pressure to obtain the desired water suction on the wedge.
9. When you have finished your inspection and the unit is no longer required, turn off the pump using the green start/stop button, disconnect the power supply, and then remove the power plug from the AC power outlet.
10. Drain the water pump. See section 4.2 “Draining the Water Pump” on page 43.

## 3.3 Operating the CFU-PWZ

This section explains how the operating procedure of the CFU-PWZ water pump.

### To operate the CFU-PWZ

1. Ensure that all connections on the pump are correctly made (see chapter 2 on page 23).
2. Ensure that all connections on the PipeWIZARD are correctly made.
3. Ensure that the filter end of the pump’s inlet tube is clean and in good working condition. For details, see section 4.1 “Maintaining the Water Inlet Tube’s Suction Filter” on page 43.

4. Place the filter end of the pump's inlet tube below the water level in the water tank.
5. Start the pump using the appropriate start/stop button (pump or remote control), depending on the power connection.
6. When you have finished your inspection and the unit is no longer required, turn off the pump using the appropriate start/stop button (pump or remote control), disconnect the power supply, and then remove the power plug from the AC power outlet.
7. Drain the water pump. See section 4.2 "Draining the Water Pump" on page 43.



---

## 4. Maintenance and Troubleshooting

---

This section presents procedures for maintaining, storing, and troubleshooting your unit.

### 4.1 Maintaining the Water Inlet Tube's Suction Filter

The following procedure should be followed to ensure that the filter is clean and in good working condition.

#### To maintain the water inlet tube's suction filter

1. Regularly clean the filter's screen:
  - a) Ensure that the screen is not clogged. There must be no clots blocking the water inlet.
  - b) If needed, use a small nonabrasive brush to clean the screen.
2. Ensure that the filter is not broken or defective. If it is, replace it with a new filter prior to operating the pump (see section 4.5 "Spare Parts" on page 45).

### 4.2 Draining the Water Pump

We recommend draining the pump:

- When you are finished using the pump.
- When you are transporting the pump.
- When you are storing the pump. Specified storage temperature is  $-20\text{ }^{\circ}\text{C}$  to  $70\text{ }^{\circ}\text{C}$  (drained).



## **CAUTION**

Leaving water in the pump when it is no longer in operation could result in damage to the pump and its accessories. In order to avoid algae accumulation in the water or to avoid the water from freezing (below 0 °C), we strongly recommend that you drain the water pump each time you finish using it.

---

### **To drain the water pump**

1. Remove the water inlet tube from the water tank.
2. For CFU03 and CFU05 pumps only: Fully open the flow control valve.
3. Start the pump using the appropriate start/stop button (on the pump or the remote control), depending on the power connection.
4. Stop the pump when it is fully drained and no more water is flowing out of the water outlet tube.

## **4.3 Cleaning the Water Pump**

A few tips should be followed when cleaning your unit.

### **To clean the water pump**

1. Disconnect the power plug from the AC power outlet (wall).
2. Insert the power cable's LEMO connector in the pump's I/O receptacle, to avoid having water enter the pump's power connection.
3. Use a damp cloth and mild soap to clean the water pump.

## **4.4 Unfreezing the Water Pump**

We recommend unfreezing the pump prior to operation:

- When the pump was in storage below 0 °C.
- When the pump was in transportation below 0 °C.
- When the pump was in any place below 0 °C.



## To unfreeze the water pump

1. Place the pump indoor where the room temperature is around 21 °C.
2. Wait 90 minutes prior to operating the water pump. If the temperature is lower than 21 °C, the waiting time is longer.

## 4.5 Spare Parts

Spare parts that can be ordered are documented in Table 3 on page 45.

**Table 3 Spare parts**

Spare Part	Order Part Number	Component Part Number	CFU03	CFU05	CFU-PWZ
CFU03	U8780008	AAIX0450	√		
CFU05	U8780009	AAIX0451		√	
CFU-PWZ	U8779727	AAIX0767			√
Inlet Feed Tube	U8831308	ABIX0632	√	√	√
Outlet / Suction Water Tube	U8831309	ABIX0633	√	√	
Outlet Water Tube	U8902974	AFIX004			√
CFU-PWZ Inlet Outlet Tubes Kit	U8779726	KITX0349			√
Vacuum Outlet Tube	U8831310	ABIX0634		√	
Filter 3/8 NPT-F 60 Mesh	U8831311	25PO0622	√	√	√
Remote Control On/Off CFU-PWZ	U8779728	ADIX1768			√

**Table 3 Spare parts (continued)**

Spare Part	Order Part Number	Component Part Number	CFU03	CFU05	CFU-PWZ
Power Supply 24 V 150 W	U8905948	EKIX0162	√	√	√

## 4.6 Troubleshooting

Table 4 on page 46 provides a list of problems, possible causes and solutions.

**Table 4 Troubleshooting**

Problem Description	Possible Cause	Solution
Fitting of a connection is difficult or impossible	Dirt on connector	Remove dirt from the connector.
	Using wrong connection technique	Follow the appropriate connection procedure as described in section 2 "Connections" on page 23.
Disconnection is difficult or impossible	Using wrong disconnection technique	Follow the appropriate disconnection procedure as described in section 2 "Connections" on page 23.
Water leak or air leak is present beneath the pump cover	Internal leak	Contact your local Evident Service Center for repair.

**Table 4 Troubleshooting (continued)**

<b>Problem Description</b>	<b>Possible Cause</b>	<b>Solution</b>
CFU05: Weak suction or no suction	Internal leak (check for the presence of air leaks beneath the pump cover)	Contact your local Evident Service Center for repair.
	Water leaks on scanner, wedge, and vacuum tube connections	Verify that the vacuum tubes are fully inserted.
	Bad suction tube connection	Follow the connection procedure in section 2.4.3 "Water Suction Connection" on page 35.
	Damaged or punctured water suction tube	Replace the water suction tube. Contact your local Evident Service Center for a replacement.
	A tube or hose has a kink (check air hose, suction tube, and vacuum outlet hose)	Remove the kink.
	Vacuum outlet hose is blocked	Unblock the hose.
	Vacuum suction holes (for the scanner or wedge) are obstructed	Remove dirt from the vacuum suction holes.
	Air supply valve is closed	Open air supply valve.
	Insufficient air supply pressure	See pressure chart in Figure 5-1 on page 57.
	Air supply is not connected	Follow the connection procedure in section 2.4.1 "Air Supply" on page 33.

**Table 4 Troubleshooting (continued)**

<b>Problem Description</b>	<b>Possible Cause</b>	<b>Solution</b>
Motor not running	Bad electric connection	Check these connections: power plug in AC power outlet (wall) <ul style="list-style-type: none"> <li>• power cable in the power supply unit's AC In connection</li> <li>• CFU-PWZ: power supply connector in the remote control's DC IN receptacle</li> <li>• pump's DC IN connection</li> </ul>
	Pump I/O power button is not pressed down	Press down the pump's I/O power button.
	CFU-PWZ: Remote control's power button is not pressed down	Press down the remote control's power button. Both the pump and the remote control's power buttons must be pressed down for the pump to work.
	Pump too cold with presence of ice in the pump	Follow the procedure in section 4.4 "Unfreezing the Water Pump" on page 44.

**Table 4 Troubleshooting (continued)**

<b>Problem Description</b>	<b>Possible Cause</b>	<b>Solution</b>
Motor is running but no water goes into the inlet tube (cannot prime)	The inlet tube or the outlet tube has a kink	Remove the kink.
	Water outlet holes (for the scanner or wedge) are obstructed	Remove dirt from the water outlet holes.
	Dirt on inlet filter	Clean the inlet filter by following the procedure in section 4.1 “Maintaining the Water Inlet Tube’s Suction Filter” on page 43.
	Bad inlet tube connection	Follow the connection procedure in section 2.3.1 “Connecting the Water Supply Tube” on page 29.
	Inlet filter is above the water line	Fill up the water tank if it is empty or sink the inlet filter to the bottom of the tank.
	Dirt on INLET connector	Remove dirt from the connector.
	CFU03 or CFU05: Valve on the pump partially or fully closed	Turn the pump valve counter clockwise to allow more water flow.
	CFU-PWZ: Valve on the PipeWIZARD partially or fully closed	Turn the PipeWIZARD valve clockwise to allow more water flow.

**Table 4 Troubleshooting (continued)**

<b>Problem Description</b>	<b>Possible Cause</b>	<b>Solution</b>
Motor running and the inlet tube is full of water but there is no water flow or low water flow	The inlet tube or the outlet tube has a kink	Remove the kink.
	Water outlet holes (for the scanner or wedge) are obstructed	Remove dirt from the water outlet holes.
	Water leaks on scanner, wedge, and tube connections	Verify that the tubes are fully inserted.
	Damaged or punctured water outlet tube	Replace the water outlet tube. Contact your local Evident Service Center for a replacement.
	Dirt on inlet filter	Clean the inlet filter by following the procedure in section 4.1 “Maintaining the Water Inlet Tube’s Suction Filter” on page 43.
	CFU03 or CFU05: Valve on the pump partially closed	Turn the pump valve counter clockwise to allow more water flow.
	CFU-PWZ: Pump has just been primed	Let the pump run for about 2 minutes.
	Bad inlet tube connection	Follow the connection procedure in section 2.3.1 “Connecting the Water Supply Tube” on page 29.

**Table 4 Troubleshooting (continued)**

<b>Problem Description</b>	<b>Possible Cause</b>	<b>Solution</b>
Presence of air bubbles in the outlet tube	Dirt on INLET connector	Remove dirt from the connector.
	Bad inlet tube connection	Follow the connection procedure in section 2.3.1 "Connecting the Water Supply Tube" on page 29.
	Damaged or punctured water inlet tube	Replace the water inlet tube. Contact your local Evident Service Center for a replacement.
	The inlet tube has a kink	Remove the kink.
	Dirt on inlet filter	Clean the inlet filter by following the procedure in section 4.1 "Maintaining the Water Inlet Tube's Suction Filter" on page 43.
	Inlet filter is above the water line	Fill up the water tank if it is empty or sink the inlet filter to the bottom of the tank.
	Pump has just been primed and air is trapped in the tube	Fully open the flow control valve and let the pump run for two minutes.
CFU-PWZ: Remote control's light is not on when the remote control's power button is pressed down and the pump is functioning normally	Burned light	Contact your local Evident Service Center for repair.

**Table 4 Troubleshooting (continued)**

<b>Problem Description</b>	<b>Possible Cause</b>	<b>Solution</b>
CFU-PWZ: Remote control's light is not on when the remote control's power button is pressed down and the pump's motor does not turn on.	Bad electric connection	Check these connections: Power plug in AC power outlet (wall) <ul style="list-style-type: none"><li>• power cable in the power supply unit's AC In connection</li><li>• power supply connector in the remote control's DC IN receptacle</li></ul>



## 5. Specifications

This final section presents the technical characteristics of the CFU Water Pumps.

### 5.1 CFU03 Specifications

Table 5 on page 53 describes the specifications for the CFU03 water pump.

**Table 5 CFU03 specifications**

Item	Specification
CFU03 case	Weight: 5.3 kg (11.68 lb) Overall dimension (L × W × H): 330 mm × 250 mm × 210 mm (12.99 in. × 9.84 in. × 8.27 in.)
Inlet feed tube	Weight: 0.8 kg (1.76 lb) Length: 3250 mm (127.95 in.) Outside diameter (OD): 16 mm (0.63 in.) Inside diameter (ID): 9 mm (0.35 in.)
Filter (for inlet feed tube)	Weight: 0.1 kg (0.22 lb) Length: 36 mm (1.42 in.) Outside diameter (OD): 58 mm (2.28 in.) Connector: 3/8 NPT female Mesh size: 60 US standard
Outlet water tube	Weight: 0.1 kg (0.22 lb) Length: 3050 mm (120.08 in.) Outside diameter (OD): 8 mm (0.31 in.) Inside diameter (ID): 5 mm (0.20 in.)

**Table 5 CFU03 specifications (continued)**

Item	Specification
Power supply adaptor 24 V 150 W	100 VAC to 240 VAC input to 24 VDC output, 3.5 A max. Power supply output LEMO connector Model: FFA Series: 2E, 4 Pins Part number: FFA.2E.304.CLAC60 Weight: 1.2 kg (2.65 lb) Overall dimension power supply unit (L × W × H): 205 mm × 80 mm × 50 mm (8.07 in. × 3.15 in. × 1.97 in.) AC power cord length: 2.2 m (7.22 ft) DC power cord length: 1.2 m (3.94 ft)
Operating temperature	0 °C to 60 °C (water)
Storage temperature	-20 °C to 70 °C (drained)
Water resistance	Designed for the IP54 rating. Pump: Outdoor use, wet locations Power supply: Indoor use (not water resistant)
Altitude	Up to 2000 m
Humidity	Maximum 80 % noncondensing
Pollution tolerance	Pollution level 2
Pump	Capacity: 3.78 L/min (1 GPM)
	Voltage: 24 VDC
	Maximum operating pressure: 620 kPa (90 psi)
	Maximum liquid temperature: 60 °C

## 5.2 CFU05 Specifications

Table 6 on page 54 describes the specifications for the CFU05 water pump.

**Table 6 CFU05 specifications**

Item	Specification
CFU05 case	Weight: 5.6 kg (12.35 lb) Overall dimension (L × W × H): 330 mm × 250 mm × 210 mm (12.99 in. × 9.84 in. × 8.27 in.)

**Table 6 CFU05 specifications (continued)**

<b>Item</b>	<b>Specification</b>
Inlet feed tube	Weight: 0.8 kg (1.76 lb) Length: 3250 mm (127.95 in.) Outside diameter (OD): 16 mm (0.63 in.) Inside diameter (ID): 9 mm (0.35 in.)
Filter (for inlet feed tube)	Weight: 0.1 kg (0.22 lb) Length: 36 mm (1.42 in.) Outside diameter (OD): 58 mm (2.28 in.) Connector: 3/8 NPT female Mesh size: 60 US standard
Outlet water tube	Weight: 0.1 kg (0.22 lb) Length: 3050 mm (120.08 in.) Outside diameter (OD): 8 mm (0.63 in.) Inside diameter (ID): 5 mm (0.20 in.)
Vacuum suction tube	Weight: 0.1 kg (0.22 lb) Length: 3050 mm (120.08 in.) Outside diameter (OD): 8 mm (0.63 in.) Inside diameter (ID): 5 mm (0.20 in.)
Vacuum outlet tube	Weight: 0.6 kg (0. lb) Length: 3130 mm (123.23 in.) Outside diameter (OD): 16 mm (0.31 in.) Inside diameter (ID): 9 mm (0.35 in.)
Air supply hose (not included)	Connector: Quick connect 0.25 in., Fed. Spec. A-A-59439 Maximum operating pressure: 689 kPa (100 psi)
Power supply adaptor 24 V 150 W	100 VAC to 240 VAC input to 24 VDC output, 3.5 A max. Power supply output LEMO connector Model: FFA Series: 2E, 4 Pins Part number: FFA.2E.304.CLAC60 Weight: 1.2 kg (2.65 lb) Overall dimension power supply unit (L × W × H): 205 mm × 80 mm × 50 mm (8.07 in. × 3.15 in. × 1.97 in.) AC power cord length: 2.2 m (7.22 ft) DC power cord length: 1.2 m (3.94 ft)
Operating temperature	0 °C to 60 °C (water)
Storage temperature	-20 °C to 70 °C (drained)

**Table 6 CFU05 specifications (continued)**

Item	Specification
Water resistance	Designed for the IP54 rating. Pump: Outdoor use, wet locations Power supply: Indoor use (not water resistant)
Altitude	Up to 2000 m
Humidity	Maximum 80 % noncondensing
Pollution tolerance	Pollution level 2
Pump	Capacity: 3.78 L/min (1 GPM)
	Voltage: 24 VDC
	Maximum operating pressure: 620 kPa (90 psi)
	Maximum liquid temperature: 60 °C
Vacuum generator	Festo <sup>a</sup> VAD-3/8 (without muffler)

a. For more details, see Festo technical data in Figure 5-1 on page 57.

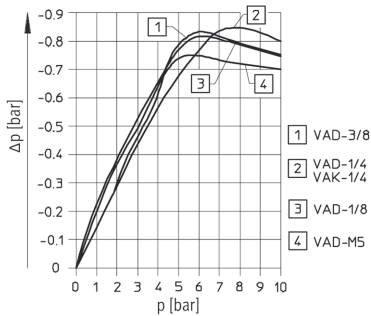
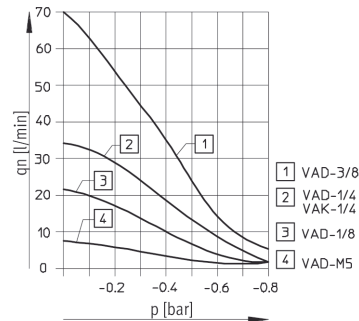
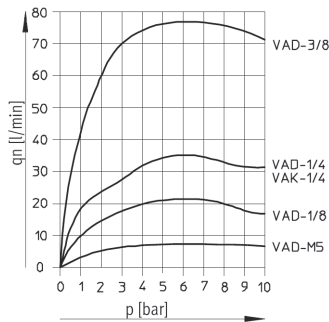
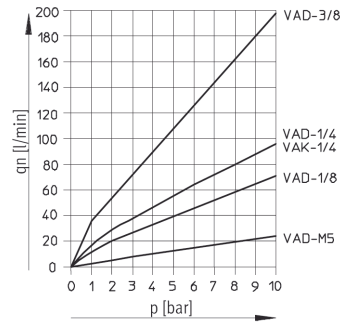
Vacuum  $\Delta p$  as a function of operating pressure  $p$ Suction capacity  $q_n$  as a function of vacuum  $p$ Suction capacity  $q_n$  as a function of operating pressure  $p$ Air consumption  $q_n$  as a function of operating pressure  $p$ **NOTE**

All provided data are subject to change.

Figure 5-1 VAD-38—Technical data courtesy of Festo AG & Co. KG.

### 5.3 CFU-PWZ Specifications

Table 7 on page 58 describes the specifications for the CFU-PWZ water pump.

**Table 7 CFU-PWZ specifications**

Item	Specification
CFU-PWZ case	Weight: 4.6 kg (10.14 lb) Overall dimension (L × W × H): 340 mm × 250 mm × 210 mm (13.39 in. × 9.84 in. × 8.27 in.)
Inlet feed tube	Weight: 0.8 kg (1.76 lb) Length: 3250 mm (127.95 in.) Outside diameter (OD): 16 mm (0.63 in.) Inside diameter (ID): 9 mm (0.35 in.)
Filter (for inlet feed tube)	Weight: 0.1 kg (0.22 lb) Length: 36 mm (1.42 in.) Outside diameter (OD): 58 mm (2.28 in.) Connector: 3/8 NPT female Mesh size: 60 US standard
Outlet water tube	Weight: 0.85 kg (1.87 lb) Length: 5.0 mm (16.40 ft) Outside diameter (OD): 13.30 mm (0.52 in.) Inside diameter (ID): 6.4 mm (0.25 in.) Connectors: Two 3/8 in. Swagelok Quick-Connect
Power supply adaptor 24 V 150 W	100 VAC to 240 VAC input to 24 VDC output, 5 A max. Power supply output LEMO connector Model: FFA Series: 2E, 4 Pins Part number: FFA.2E.304.CLAC60 Weight: 1.2 kg (2.65 lb) Overall dimension power supply unit (L × W × H): 205 mm × 80 mm × 50 mm (8.07 in. × 3.15 in. × 1.97 in.) AC power cord length: 2.2 m (7.22 ft) DC power cord length: 1.2 m (3.94 ft)

**Table 7 CFU-PWZ specifications (continued)**

Item	Specification
Remote control assembly	Remote control output LEMO connector Model: FFA Series: 2E, 4 Pins Part number: FFA.2E.304.CLAC70 Overall dimension control box (L × W × H): 105 mm × 75 mm × 71 mm (4.13 in. × 2.95 in. × 2.90 in.) Weight: 1.3 kg (2.87 lb) Cord length: 10.7 m (35.11 ft) Control box connector: Power supply DC out Cord connector: CFU-PWZ DC IN
Operating temperature	0 °C to 60 °C
Storage temperature	-20 °C to 70 °C (drained)
Water resistance	Designed for the IP54 rating. Pump: Outdoor use, wet locations Remote power button and power supply: Indoor use (not water resistant)
Altitude	Up to 2000 m
Humidity	Maximum 80 % noncondensing
Pollution tolerance	Pollution level 2
Pump	Capacity: 6 L/min (1.6 GPM)
	Voltage: 24 VDC
	Maximum operating pressure: 689 kPa (100 psi)
	Maximum liquid temperature: 60 °C





---

## List of Figures

---

Figure i-1	Rating label location .....	1
Figure 1-1	Top, left, and front sides of the water pump case .....	17
Figure 1-2	Right, bottom, and back sides of the water pump case .....	17
Figure 1-3	Right side of CFU03 .....	18
Figure 1-4	Left side of CFU03 .....	18
Figure 1-5	Right side of CFU05 .....	19
Figure 1-6	Left side of CFU05 .....	19
Figure 1-7	Right side of CFU-PWZ .....	20
Figure 1-8	Left side of CFU-PWZ .....	20
Figure 2-1	Position of the Start/Stop button when the pump is turned off .....	23
Figure 2-2	Color-coded connections with male connectors on pump .....	25
Figure 2-3	Plastic quick-coupling connections .....	25
Figure 2-4	Metallic connection with female connector on pump .....	26
Figure 2-5	Connecting the power supply to a pump .....	27
Figure 2-6	Connecting the remote control to a pump .....	28
Figure 2-7	Water supply tube .....	29
Figure 2-8	Water supply INLET connection .....	30
Figure 2-9	Water OUTLET connection .....	31
Figure 2-10	Disconnecting the water outlet tube .....	31
Figure 2-11	CFU-PWZ water OUTLET connection .....	32
Figure 2-12	CFU05—Color-coded connections of the vacuum system .....	33
Figure 2-13	Compressed AIR connection .....	34
Figure 2-14	VACUUM OUTLET connection .....	35
Figure 2-15	CFU05—Water SUCTION connector .....	36
Figure 2-16	CFU05—Water SUCTION connection .....	36
Figure 2-17	CFU05—Disconnecting the water suction tube .....	37
Figure 5-1	VAD-38—Technical data courtesy of Festo AG & Co. KG. ....	57



---

## List of Tables

---

Table 1	Content of the rating labels .....	2
Table 2	Package contents .....	15
Table 3	Spare parts .....	45
Table 4	Troubleshooting .....	46
Table 5	CFU03 specifications .....	53
Table 6	CFU05 specifications .....	54
Table 7	CFU-PWZ specifications .....	58

