



NORTEC 600

Eddy Current Flaw Detector

User's Manual

DMTA-10040-01EN — Rev. H
October 2022

This instruction manual contains essential information on how to use this Evident product safely and effectively. Before using this product, thoroughly review this instruction manual. Use the product as instructed. Keep this instruction manual in a safe, accessible location.

EVIDENT SCIENTIFIC, INC., 48 Woerd Avenue, Waltham, MA 02453, USA

Copyright © 2022 by Evident. All rights reserved. No part of this publication may be reproduced, translated, or distributed without the express written permission of Evident.

This document was prepared with particular attention to usage to ensure the accuracy of the information contained therein, and corresponds to the version of the product manufactured prior to the date appearing on the title page. There could, however, be some differences between the manual and the product if the product was modified thereafter.

The information contained in this document is subject to change without notice.

Part number: DMTA-10040-01EN

Rev. H

October 2022

Printed in the United States of America

The microSD logo is a trademark of SD-3C, LLC.



All brands are trademarks or registered trademarks of their respective owners and third party entities.

Table of Contents

List of Abbreviations	9
Important Information – Please Read Before Use	11
Intended Use	11
Instruction Manual	11
Device Compatibility	12
Repair and Modification	12
Safety Symbols	12
Safety Signal Words	13
Note Signal Words	14
Safety	14
Warnings	14
Battery Precautions	15
Regulations for Shipping Products with Lithium-Ion Batteries	17
Equipment Disposal	17
BC (Battery Charger - California, USA Community)	17
CE (European Community)	18
UKCA (United Kingdom)	18
RCM (Australia)	18
WEEE Directive	18
China RoHS	19
Korea Communications Commission (KCC)	20
EMC Directive Compliance	20
FCC (USA) Compliance	21
ICES-001 (Canada) Compliance	22
Warranty Information	22
Technical Support	23

Introduction	25
1. Instrument Overview	27
1.1 Operating Principle	27
1.2 Contents of the Case	28
1.3 Connectors	29
1.4 Power Requirements	32
1.4.1 Charger/Adapter	33
1.4.2 Battery Compartment	36
1.4.3 Lithium-Ion Battery	37
1.4.4 Alkaline Batteries	38
1.5 Optional microSD Card Installation	39
1.6 NORTEC 600 Hardware Features	40
1.6.1 Hardware Overview	41
1.6.1.1 Front Panel and SmartKnob	42
1.6.1.2 Keypad	43
1.6.2 Connectors	48
1.6.2.1 Probe and BNC Connectors	48
1.6.2.2 Input/Output (I/O) and VGA OUT Connectors	48
1.6.2.3 microSD and USB Port	50
1.6.3 Various Hardware Features	51
1.6.3.1 Instrument Stand	51
1.6.3.2 O-Ring Gasket and Membrane Seals	52
1.6.3.3 Display Protection	52
1.6.4 Environmental Ratings	52
2. Software User Interface	55
2.1 Starting Up the Instrument	55
2.1.1 Navigating the Application Menu	56
2.1.2 Main Inspection Screen	57
2.2 Selecting from the Menus	60
2.3 Displaying All Functions Simultaneously — ALL SETTINGS Menu	60
2.3.1 Using the ALL SETTINGS Menu	61
2.3.2 Special Functions in the ALL SETTINGS Menu	62
2.4 Displaying Real-Time Readings	62
2.4.1 Enabling Real-Time Readings on the Main Inspection Screen	65
2.4.2 Enabling the Real-Time Readings in Full-Screen Mode — FULL NEXT key	66

3. Initial Setup	69
3.1 Setting the User Interface Language and the Decimal Symbol	69
3.2 Setting the Clock	70
3.3 Changing the Location of Saved Files	70
3.4 Changing the Display Settings	71
3.5 Changing the Display Brightness	72
3.6 Adjusting Auto Erase	73
3.7 Selecting the Startup Screen	73
3.8 Enabling Knobless Entry for Harsh Environments	74
4. Control Functions	75
4.1 PowerLink	75
4.2 Instrument Controls	76
4.2.1 Display	77
4.2.2 Power and Lock Buttons	77
4.2.3 Direct-Function Keys	77
4.2.4 Menu Keys	83
4.2.5 Knob	84
4.2.6 Hidden Function — Screen Capture	84
4.2.7 Knobless Entry	84
4.2.8 Ambidextrous Controls	85
4.2.9 FULL NEXT key	86
4.3 Menus	88
4.3.1 Frequency (FREQ 1) Menu — MAIN FILTER Key	88
4.3.2 Filter Menu — MAIN FILTER Key	90
4.3.3 Special Menu — MAIN FILTER Key	91
4.3.4 Display Menu — DISP Key	93
4.3.5 Alarm Menu — ALARM Key	97
4.3.6 Memory Menu — MEM Key	98
4.3.7 Memory Text Editor	102
4.3.8 Advanced Setup Menu — ADV SETUP Menu Key	105
4.4 Dual Frequency Menus	115
4.4.1 Frequency (FREQ 1) Menu — MAIN FILTER Key	115
4.4.2 Frequency (FREQ 2) Menu — MAIN FILTER Key	117
4.4.3 MIX Menu in Dual Frequency — MAIN FILTER Key	119
4.4.4 Filter Menu in Dual Frequency — MAIN FILTER Key	120
4.4.5 Special Menu in Dual Frequency — MAIN FILTER Key	120
4.4.6 Display Menu in Dual Frequency — DISP Key	122
4.4.7 ALARM Menu in Dual Frequency — ALARM Key	124

5. Using the Instrument	125
5.1 Common NORTEC 600 Applications	126
5.1.1 Detecting Surface-Breaking Cracks – General Purpose Procedure for All NORTEC 600 Models	126
5.1.2 Inspecting Fastener Holes with a Rotating Scanner – NORTEC 600S and NORTEC 600D Models	132
5.1.3 Detecting Sub-Surface Cracks at Very Low Frequency – All NORTEC 600 Models	141
5.1.4 Inspecting Welds on Ferromagnetic Materials – All NORTEC 600 Models	147
5.1.5 Evaluating Paint Thickness on Ferromagnetic Material – All NORTEC 600 Models	154
5.1.6 Measuring Conductivity and Nonconductive Coating Thickness – NORTEC 600C, NORTEC 600S, and NORTEC 600D Models	160
5.1.7 Inspecting Aircraft Wheels – All NORTEC 600 Models	166
5.1.8 Inspecting Critical Fastener Holes with a Controlled Translation (Indexing) Scanner – NORTEC 600S and NORTEC 600D Models	172
5.2 Special and Educational Applications	179
5.2.1 Using the Impedance Plane Theory and Display – All NORTEC 600 Models	180
5.2.2 Sorting Metals by Evaluating Conductivity – All NORTEC 600 Models . 183	
5.2.3 Evaluating Nonconductive Coating (Paint) Thickness – All NORTEC 600 Models	187
5.2.4 Evaluating Metal Thickness and Using Thickness Curve Theory – All NORTEC 600 Models	191
5.3 Advanced Dual Frequency Applications	195
5.3.1 Detecting Corrosion Using Dual Frequency to Reduce the Pillowing Effect – NORTEC 600D Model	196
5.3.2 Detecting Sub-Surface Cracks Using Dual Frequency in a Lap Splice with Anodized and Alodine Rivets – NORTEC 600D Model	207
5.3.3 Inspecting Heat Exchanger Tubing Using Dual Frequency – NORTEC 600D Model	221
5.4 Heat Exchanger Tubing Applications	234
5.4.1 ECT Pitting, Wear, and Cracks – NORTEC 600D Model	236
5.4.1.1 Using the Application	239
5.4.1.2 Displaying Reference Signals	254
5.4.1.3 Using the ALL-IN-1 (Strip Chart) Display	255
5.4.2 ECT Erosion and Corrosion – NORTEC 600D Model	257
5.4.3 RFT Pitting and Wear – NORTEC 600D Model	262
5.4.3.1 Using the Application	265
5.4.3.2 Enhancing the Signal with the LO PASS Filter	274

5.4.3.3	Using the ALL-IN-1 Display	275
5.4.4	RFT Erosion and Corrosion – NORTEC 600D Model	277
5.4.4.1	Using the Application	278
5.4.4.2	Using the Overlay Display	283
5.4.4.3	Optimizing the Frequency	284
5.4.5	NFT Pitting (Differential) – NORTEC 600D Model	285
5.4.6	NFT Erosion and Corrosion (Absolute) – NORTEC 600D Model	292
5.5	Alarm Menus	298
5.5.1	Alarm DEFINE Menu	298
5.5.2	Selecting the Alarm Shape and Position – Alarm 1, 2, and 3 Menus ..	300
5.5.3	SWEEP alarm	301
6.	NORTEC PC Software	303
6.1	Importing Files	303
6.2	Capturing a Screen Image Using NORTEC PC	306
6.3	Upgrading the Instrument Software Using NORTEC PC	308
6.4	Upgrading the Instrument Software without NORTEC PC	311
6.5	Creating a PDF	313
6.6	Issuing Remote Commands to the NORTEC 600 from a PC	314
6.7	Remotely Controlling the NORTEC 600 from a PC	323
6.8	Managing Files on the NORTEC 600 from your PC	325
6.9	Unlocking NORTEC 600 Upgrade Options with your PC	328
6.10	Backing Up the NORTEC 600 Files	330
6.11	Restoring or Cloning the NORTEC 600 Files	332
7.	Maintenance and Troubleshooting	335
7.1	Lithium-Ion Battery	335
7.2	Error Messages	336
7.3	Probe Care and Diagnostics	337
Appendix A:	Specifications	339
A.1	General and Environmental Specifications	339
A.2	Input/Output Specifications	344
Appendix B:	Accessories, Replacement Parts, and Upgrades	347
List of Figures	353
List of Tables	363

List of Abbreviations

A/C	air conditioner
AC	alternating current
CD-ROM	compact disc read-only memory
DC	direct current
ECT	eddy current testing
EFUP	environment-friendly use period
GB	gigabyte
I/O	input-output
ID	identification
ID	internal diameter
IP	ingress protection
LCD	liquid crystal display
LED	light-emitting diode
MIL	military
mil	one-thousandths of one inch (0.0254 mm)
N/A	not applicable
NFT	near-field testing
OD	outside diameter
OEM	original equipment manufacturer
PC	personal computer
RFT	remote-field testing
SD	secure digital (card)
SPC	statistical process control
USB	universal serial bus

VGA video graphics array
WT wall thickness

Important Information — Please Read Before Use

Intended Use

The NORTEC 600 is designed to perform nondestructive inspections on industrial and commercial materials.



WARNING

Do not use the NORTEC 600 for any purpose other than its intended use. It must never be used to inspect or examine human or animal body parts.

Instruction Manual

This instruction manual contains essential information on how to use this product safely and effectively. Before using this product, thoroughly review this instruction manual. Use the product as instructed. Keep this instruction manual in a safe, accessible location.

IMPORTANT

Some of the details of components illustrated in this manual may differ from the components installed on your device. However, the operating principles remain the same.

Device Compatibility

Only use this device with the approved ancillary equipment provided by Evident. Equipment provided by Evident and approved for use with this device is described later in this manual.



CAUTION

Always use equipment and accessories that meet Evident specifications. Using incompatible equipment could cause equipment malfunction and/or damage, or human injury.

Repair and Modification

This device does not contain any user-serviceable parts. Opening the device might void the warranty.



CAUTION

In order to prevent human injury and/or equipment damage, do not disassemble, modify, or attempt to repair the device.

Safety Symbols

The following safety symbols might appear on the device and in the instruction manual:



General warning symbol

This symbol is used to alert the user to potential hazards. All safety messages that follow this symbol shall be obeyed to avoid possible harm or material damage.



High voltage warning symbol

This symbol is used to alert the user to potential electric shock hazards greater than 1000 volts. All safety messages that follow this symbol shall be obeyed to avoid possible harm.

Safety Signal Words

The following safety symbols might appear in the documentation of the device:



DANGER

The DANGER signal word indicates an imminently hazardous situation. It calls attention to a procedure, practice, or the like, which, if not correctly performed or adhered to, will result in death or serious personal injury. Do not proceed beyond a DANGER signal word until the indicated conditions are fully understood and met.



WARNING

The WARNING signal word indicates a potentially hazardous situation. It calls attention to a procedure, practice, or the like, which, if not correctly performed or adhered to, could result in death or serious personal injury. Do not proceed beyond a WARNING signal word until the indicated conditions are fully understood and met.



CAUTION

The CAUTION signal word indicates a potentially hazardous situation. It calls attention to an operating procedure, practice, or the like, which, if not correctly performed or adhered to, may result in minor or moderate personal injury, material damage, particularly to the product, destruction of part or all of the product, or loss of data. Do not proceed beyond a CAUTION signal word until the indicated conditions are fully understood and met.

Note Signal Words

The following note signal words could appear in the documentation of the device:

IMPORTANT

The IMPORTANT signal word calls attention to a note that provides important information, or information essential to the completion of a task.

NOTE

The NOTE signal word calls attention to an operating procedure, practice, or the like, which requires special attention. A note also denotes related parenthetical information that is useful, but not imperative.

TIP

The TIP signal word calls attention to a type of note that helps you apply the techniques and procedures described in the manual to your specific needs, or provides hints on how to effectively use the capabilities of the product.

Safety

Before turning on the device, verify that the correct safety precautions have been taken (see the following warnings). In addition, note the external markings on the device, which are described under “Safety Symbols.”

Warnings



WARNING

General Warnings

- Carefully read the instructions contained in this instruction manual prior to turning on the device.
- Keep this instruction manual in a safe place for further reference.

- Follow the installation and operation procedures.
- It is imperative to respect the safety warnings on the device and in this instruction manual.
- If the equipment is used in a manner not specified by the manufacturer, the protection provided by the equipment could be impaired.
- Do not install substitute parts or perform any unauthorized modification to the device.
- Service instructions, when applicable, are for trained service personnel. To avoid the risk of electric shock, do not perform any work on the device unless qualified to do so. For any problem or question regarding this device, contact Evident or an authorized Evident representative.
- Do not touch the connectors directly by hand. Otherwise, a malfunction or electric shock may result.
- Do not allow metallic or foreign objects to enter the device through connectors or any other openings. Otherwise, a malfunction or electric shock may result.

**WARNING****Electrical Warning**

The device must only be connected to a power source corresponding to the type indicated on the rating label.

**CAUTION**

If a non-approved power supply cord not dedicated to Evident products is used, Evident will not be able to ensure the electrical safety of the equipment.

Battery Precautions**CAUTION**

- Before disposing of a battery, check your local laws, rules, and regulations, and follow them accordingly.

- Transportation of lithium-ion batteries is regulated by the United Nations under the United Nations Recommendations on the Transport of Dangerous Goods. It is expected that governments, intergovernmental organizations, and other international organizations shall conform to the principles laid down in these regulations, thus contributing to worldwide harmonization in this field. These international organizations include the International Civil Aviation organization (ICAO), the International Air Transport Association (IATA), the International Maritime Organization (IMO), the US Department of Transportation (USDOT), Transport Canada (TC), and others. Please contact the transporter and confirm current regulations before transportation of lithium-ion batteries.
- For California (USA) only:
The device may contain a CR battery. The CR battery contains perchlorate material, and special handling may be required. Refer to <http://www.dtsc.ca.gov/hazardouswaste/perchlorate>.
- Do not open, crush, or perforate batteries; doing so could cause injury.
- Do not incinerate batteries. Keep batteries away from fire and other sources of extreme heat. Exposing batteries to extreme heat (over 80 °C) could result in an explosion or personal injury.
- Do not drop, hit, or otherwise abuse a battery, as doing so could expose the cell contents, which are corrosive and explosive.
- Do not short-circuit the battery terminals. A short circuit could cause injury and severe damage to a battery making it unusable.
- Do not expose a battery to moisture or rain; doing so could cause an electric shock.
- Only use an external charger approved by Evident to charge the batteries.
- Only use batteries supplied by Evident.
- Do not store batteries that have less than 40 % remaining charge. Recharge batteries to between 40 % and 80 % capacity before storing them.
- During storage, keep the battery charge between 40 % and 80 %.
- Do not leave batteries in the NORTEC 600 unit during device storage.

Regulations for Shipping Products with Lithium-Ion Batteries

IMPORTANT

When shipping a Li-ion battery or batteries, be sure to follow all local transportation regulations.



WARNING

Damaged batteries cannot be shipped through normal routes — DO NOT ship damaged batteries to Evident. Contact your local Evident representative or material disposal professionals.

Equipment Disposal

Before disposing of the NORTEC 600, check your local laws, rules, and regulations, and follow them accordingly.

BC (Battery Charger - California, USA Community)



The BC marking indicates that this product has been tested and complies with the Appliance Efficiency Regulations as stated in the California Code of Regulations Title 20, Sections 1601 through 1608 for Battery Charger Systems. The internal battery charger within this device has been tested and certified pursuant to the California Energy Commission's (CEC) requirements; this device is listed on the online CEC's (T20) database.

CE (European Community)



This device complies with the requirements of directive 2014/30/EU concerning electromagnetic compatibility, directive 2014/35/EU concerning low voltage, and directive 2015/863 which amends 2011/65/EU concerning restriction of hazardous substances (RoHS). The CE marking is a declaration that this product conforms to all the applicable directives of the European Community.

UKCA (United Kingdom)



This device complies with the requirements of the Electromagnetic Compatibility Regulations 2016, the Electrical Equipment (Safety) Regulations 2016, and the Restriction of the Use of Certain Hazardous Substances in Electrical and Electronic Equipment Regulations 2012. The UKCA marking indicates compliance with the above regulations.

RCM (Australia)



The regulatory compliance mark (RCM) label indicates that the product complies with all applicable standards, and has been registered with the Australian Communications and Media Authority (ACMA) for placement on the Australian market.

WEEE Directive



In accordance with European Directive 2012/19/EU on Waste Electrical and Electronic Equipment (WEEE), this symbol indicates that the product must not be disposed of as unsorted municipal waste, but should be collected separately. Refer to your local Evident distributor for return and/or collection systems available in your country.

China RoHS

China RoHS is the term used by industry generally to describe legislation implemented by the Ministry of Information Industry (MII) in the People's Republic of China for the control of pollution by electronic information products (EIP).



The China RoHS mark indicates the product's Environment-Friendly Use Period (EFUP). The EFUP is defined as the number of years for which listed controlled substances will not leak or chemically deteriorate while in the product. The EFUP for the NORTEC 600 has been determined to be 15 years.

Note: The Environment-Friendly Use Period (EFUP) is not meant to be interpreted as the period assuring functionality and product performance.



电器电子产品有害
物质限制使用
标志

本标志是根据“电器电子产品有害物质限制使用管理办法”以及“电子电气产品有害物质限制使用标识要求”的规定，适用于在中国销售的电器电子产品上的电器电子产品有害物质使用限制标志。

（注意）电器电子产品有害物质限制使用标志内的数字为在正常的使用条件下有害物质等不泄漏的期限，不是保证产品功能性能的期间。

产品中有害物质的名称及含量

部件名称		有害物质					
		铅及其化合物 (Pb)	汞及其化合物 (Hg)	镉及其化合物 (Cd)	六价铬及其化合物 (Cr(VI))	多溴联苯 (PBB)	多溴二苯醚 (PBDE)
主体	机构部件	×	○	○	○	○	○
	光学部件	×	○	○	○	○	○
	电气部件	×	○	○	○	○	○

产品中有害物质的名称及含量

部件名称	有害物质					
	铅及其化合物 (Pb)	汞及其化合物 (Hg)	镉及其化合物 (Cd)	六价铬及其化合物 (Cr(VI))	多溴联苯 (PBB)	多溴二苯醚 (PBDE)
附件	×	○	○	○	○	○

本表格依据 SJ/T 11364 的规定编制。

○：表示该有害物质在该部件所有均质材料中的含量均在 GB/T26572 规定的限量要求以下。

×：表示该有害物质至少在该部件的某一均质材料中的含量超出 GB/T26572 规定的限量要求。

Korea Communications Commission (KCC)



Seller and user shall be noticed that this equipment is suitable for electromagnetic equipment for office work (class A) and it can be used outside the home. This device complies with the EMC requirements of Korea.

The MSIP code for the device is the following: MSIP-REM-OYN-N600.

이 기기는 업무용 환경에서 사용할 목적으로 적합성평가를 받은 기기로서 가정용 환경에서 사용하는 경우 전파간섭의 우려가 있습니다.

EMC Directive Compliance

This equipment generates and uses radio-frequency energy and, if not installed and used properly (that is, in strict accordance with the manufacturer's instructions), may cause interference. The NORTEC 600 has been tested and found to comply with the limits for an industrial device in accordance with the specifications of the EMC directive.

FCC (USA) Compliance

NOTE

This product has been tested and found to comply with the limits for a Class A digital device, pursuant to Part 15 of the FCC Rules. These limits are designed to provide reasonable protection against harmful interference when the product is operated in a commercial environment. This product generates, uses, and can radiate radio frequency energy, and if not installed and used in accordance with the instruction manual, might cause harmful interference to radio communications. Operation of this product in a residential area is likely to cause harmful interference, in which case you will be required to correct the interference at your own expense.

IMPORTANT

Changes or modifications not expressly approved by the party responsible for compliance could void the user's authority to operate the product.

FCC Supplier's Declaration of Conformity

Hereby declares that the product,

Product name: NORTEC 600

Models: NORTEC 600 (Basic model), NORTEC 600C (Conductivity model),
NORTEC 600S (Scanner model), NORTEC 600D (Dual Frequency)

Conforms to the following specifications:

FCC Part 15, Subpart B, Section 15.107 and Section 15.109.

Supplementary information:

This device complies with Part 15 of the FCC Rules. Operation is subject to the following two conditions:

- (1) This device may not cause harmful interference.
- (2) This device must accept any interference received, including interference that may cause undesired operation.

Responsible party name:

EVIDENT SCIENTIFIC, INC.

Address:

48 Woerd Avenue, Waltham, MA 02453, USA

Phone number:

+1 781-419-3900

ICES-001 (Canada) Compliance

This Class A digital apparatus complies with Canadian ICES-001.

Cet appareil numérique de la classe A est conforme à la norme NMB-001 du Canada.

Warranty Information

Evident guarantees your Evident product to be free from defects in materials and workmanship for a specific period, and in accordance with conditions specified in the Terms and Conditions available at <https://www.olympus-ims.com/en/terms/>.

The Evident warranty only covers equipment that has been used in a proper manner, as described in this instruction manual, and that has not been subjected to excessive abuse, attempted unauthorized repair, or modification.

Inspect materials thoroughly on receipt for evidence of external or internal damage that might have occurred during shipment. Immediately notify the carrier making the delivery of any damage, because the carrier is normally liable for damage during shipment. Retain packing materials, waybills, and other shipping documentation needed in order to file a damage claim. After notifying the carrier, contact Evident for assistance with the damage claim and equipment replacement, if necessary.

This instruction manual explains the proper operation of your Evident product. The information contained herein is intended solely as a teaching aid, and shall not be used in any particular application without independent testing and/or verification by the operator or the supervisor. Such independent verification of procedures becomes increasingly important as the criticality of the application increases. For this reason, Evident makes no warranty, expressed or implied, that the techniques, examples, or procedures described herein are consistent with industry standards, nor that they meet the requirements of any particular application.

Evident reserves the right to modify any product without incurring the responsibility for modifying previously manufactured products.

Technical Support

Evident is firmly committed to providing the highest level of customer service and product support. If you experience any difficulties when using our product, or if it fails to operate as described in the documentation, first consult the user's manual, and then, if you are still in need of assistance, contact our After-Sales Service. To locate the nearest service center, visit the Service Centers page on the Evident Scientific Web site.

Introduction

This user's manual provides operating instructions for the Evident NORTEC 600 instrument, which uses eddy currents to detect surface flaws in various types of metals (see Figure i-1 on page 25). The information in this manual is organized to explain the technology, safety details, hardware, and software. Practical inspection examples help the user become familiar with the instrument's capabilities.

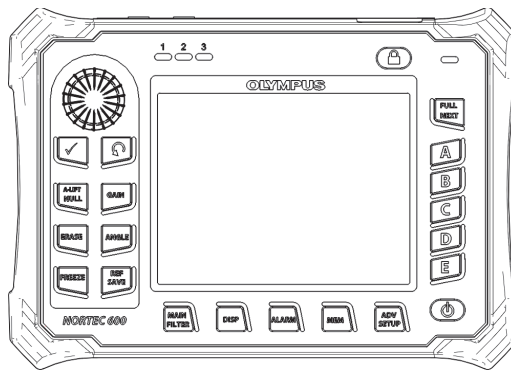

Figure i-1 The NORTEC 600 instrument

1. Instrument Overview

This chapter provides a brief overview of the Evident NORTEC 600 eddy current flaw detector, and includes the principle of operation, accessories, and all common operational requirements.

1.1 Operating Principle

The NORTEC 600 is a small, lightweight flaw detector designed to make fast, accurate, and repeatable measurements on conductive materials such as aluminum, copper, stainless steel, steel, and titanium.

The NORTEC 600 uses electromagnetic induction to detect flaws in conductive materials. Electromagnetic induction is achieved with a coil that carries a current and that is placed in proximity to the test material. The alternating current in the coil generates a changing magnetic field that interacts with the test material and causes eddy currents. Variations in the phase and magnitude of these eddy currents are monitored. Variations in the electrical conductivity or magnetic permeability of the test object, or the presence of any flaws, will cause a change in eddy current and a corresponding change in the phase and amplitude of the measured current.

Eddy current testing can detect very small cracks in or near the surface of non-ferrous material, and it is also useful for making electrical conductivity and coating thickness measurements. The surfaces being tested need minimal preparation.

1.2 Contents of the Case

The NORTEC 600 comes with several key accessories (see Figure 1-1 on page 29):

- ISO-15548 certificate or calibration certificate (short form of the ISO-15548) (Evident P/N: 7922035 [U8030145]).
- Charger/adaptor (Evident P/N: EP-MCA-X), where “X” denotes the AC power cord type (see Table 12 on page 349).
- AC power cord
- *Getting Started* leaflet (Evident P/N: DMTA-10039-01YY), where “YY” denotes the language (see Table 15 on page 350 for order numbers).
- NORTEC 600 *User’s Manual* and PC interface program on CD-ROM (Evident P/N: N600-CD [U8030151])
- Instrument transport case (P/N: 600-TC [U8780294])
- Universal PowerLink eddy current probe cable (Evident P/N: 9122083 [U8800073]). Although in some countries this item may be included, for most countries it is optional and must be purchased separately. Please contact your Evident representative for more details.
- microSD memory card 2 GB (1 internal, 1 external) (Evident P/N: MICROSD-ADP-2GB [U8779307])
- USB 2.0 (mini-AB) to PC cable (Evident P/N: EPLTC-C-USB-A-6 [U8840031])
- 73 watt-hour battery for 600 Series products; 10.8 V, 6.8 Ah, 73 Wh (Evident P/N: 600-BAT-L-2 [U8760058])
- AA battery holder (tray) for emergency use (Evident P/N: 600-BAT-AA [U8780295])
- Factory-installed hand strap on left side of NORTEC 600 instrument (Evident P/N: 38DLP-HS [U8779371])

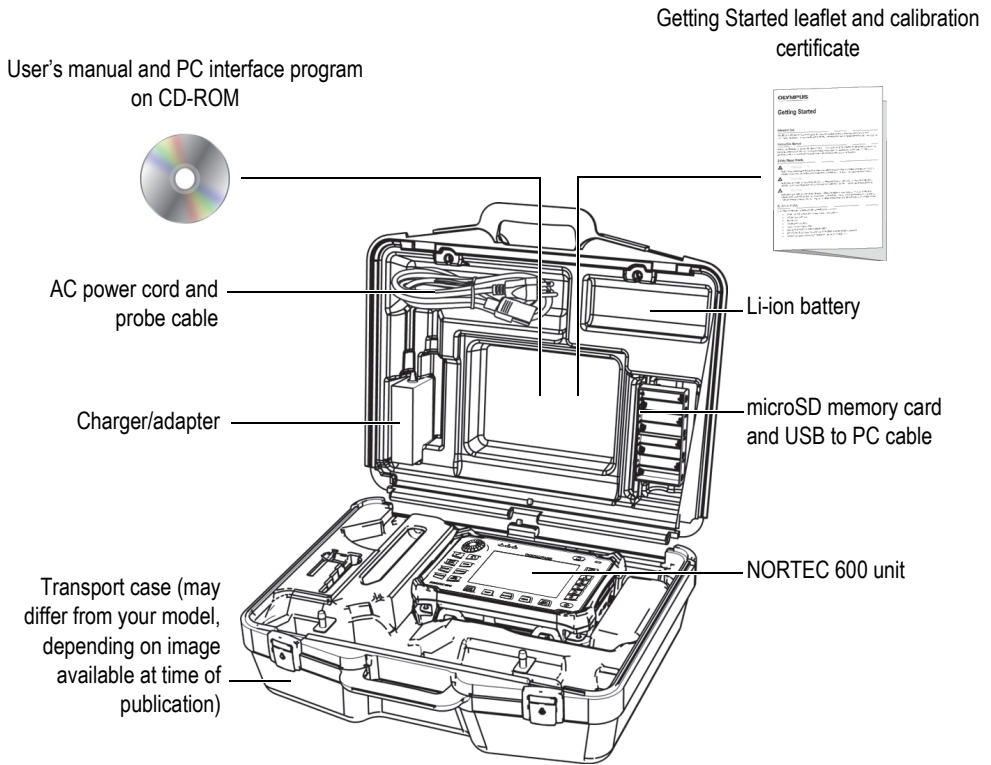

Figure 1-1 Transport case contents

A list of optional accessories available from Evident can be found in “Accessories, Replacement Parts, and Upgrades” on page 347.

1.3 Connectors

Figure 1-2 on page 30 illustrates the connections of the NORTEC 600 instrument with the charger/adaptor, the microSD card, and a PC.

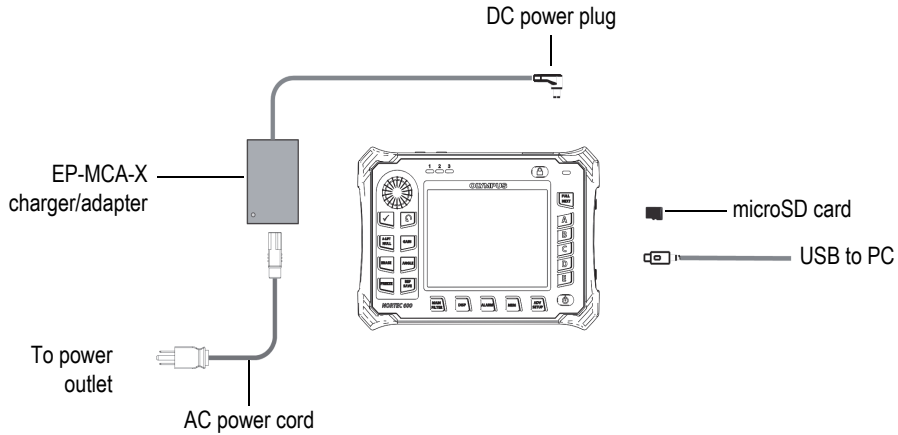

Figure 1-2 The NORTEC 600 connections



WARNING

Use only the AC power cord supplied with your instrument, unless specifically instructed in the manual. Using an unauthorized power cord may result in damage to instruments or serious injury to the user.

The DC power, PROBE, and BNC connectors are located on the top end of the NORTEC 600 (see Figure 1-3 on page 30).

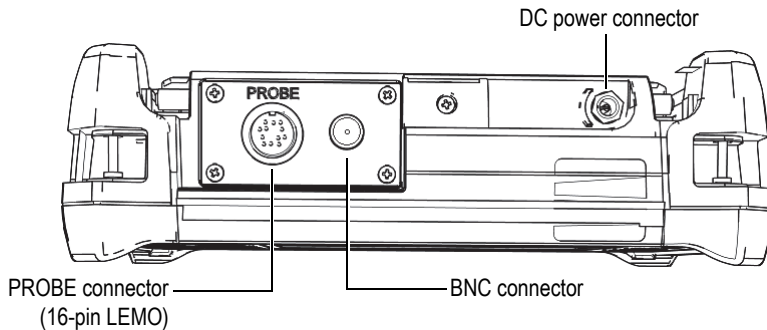

Figure 1-3 The top end connectors



CAUTION

Do not allow metallic or foreign objects to enter the device through connectors or any other openings. Otherwise, an electric shock or malfunction may result.

The USB port and the removable microSD memory card slot are located on the right-hand side of the instrument, hidden behind the input/output (I/O) door (see Figure 1-4 on page 31).

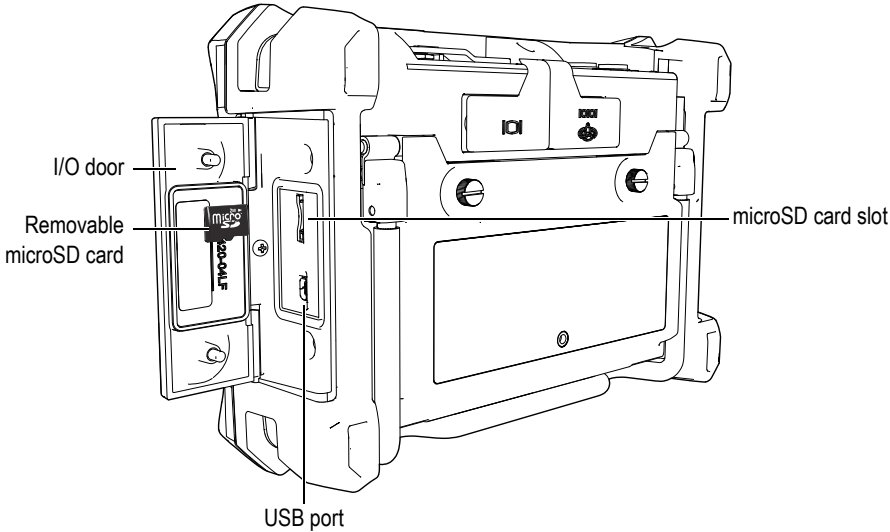

Figure 1-4 The connectors behind the input/output (I/O) door

The I/O and the VGA OUT connectors are located at the back of the instrument, in the upper section (see Figure 1-5 on page 32). A rubber cover protects each connector.

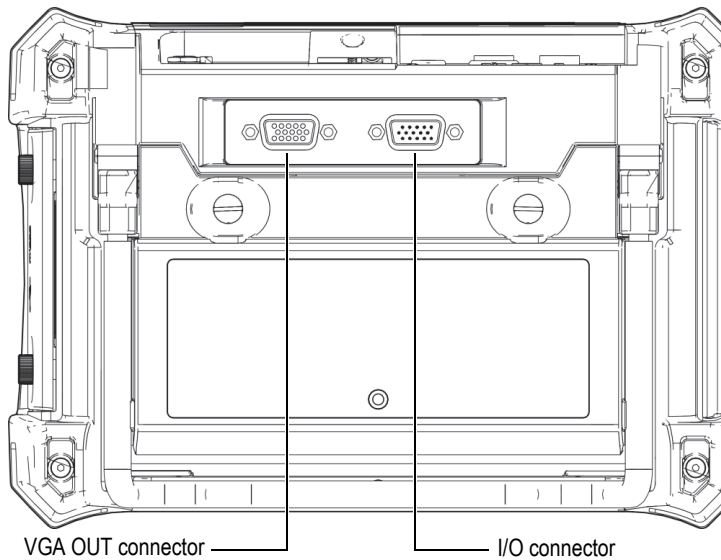

Figure 1-5 The VGA OUT and I/O connectors

1.4 Power Requirements

The NORTEC 600 is designed to operate using three power supply methods:

- Directly from the NORTEC 600 charger/adaptor
- Internal lithium-ion battery
- Internal alkaline battery holder

Press the power button (🔌) to turn on the NORTEC 600 (see Figure 1-6 on page 33). Pressing this button once causes an initial beep, which is followed by the instrument startup screen, and then a second beep approximately five seconds later.

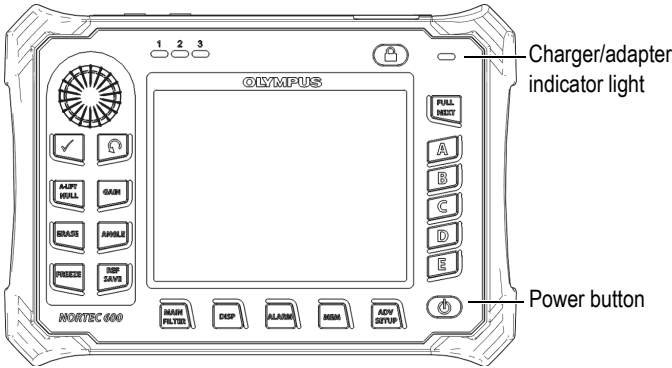

Figure 1-6 Location of the NORTEC 600 power button and indicator light

1.4.1 Charger/Adapter

A NORTEC 600 charger/adaptor is provided with every instrument. This charger/adaptor is the primary method for powering the NORTEC 600, with or without a battery installed. It is also used to charge the lithium-ion rechargeable battery when it is installed in the instrument. A charger/adaptor indicator light on the front panel of the unit displays the current status of the charger/adaptor (see Figure 1-6 on page 33 and Figure 1-7 on page 33).



Figure 1-7 The charger/adaptor indicator light on the front panel



WARNING

Use only the power cord supplied with your instrument, unless specifically instructed in the manual. Using an unauthorized power cord may result in damage to instruments or serious injury to the user.

**WARNING**

The NORTEC 600 charger/adapter (P/N: EP-MCA-X) is designed to power the NORTEC 600 and charge the lithium-ion battery only (P/N: 600-BAT-L-2 [U8760058]). Do not attempt to charge any other types of batteries, including alkaline batteries in the battery holder (P/N: 600-BAT-AA [U8780295]), and do not attempt to use any other charger/adapter. Doing so might cause an explosion or injury.

Do not attempt to power or charge other electronic equipment with the charger/adapter (P/N: EP-MCA-X), unless specifically instructed in the manual. Misuse of the charger/adapter can cause other batteries and/or instruments to explode, which could lead to serious injury or death.

To connect the charger/adapter

1. Connect the AC power cord to the charger/adapter and to an appropriate power outlet (see Figure 1-8 on page 34).

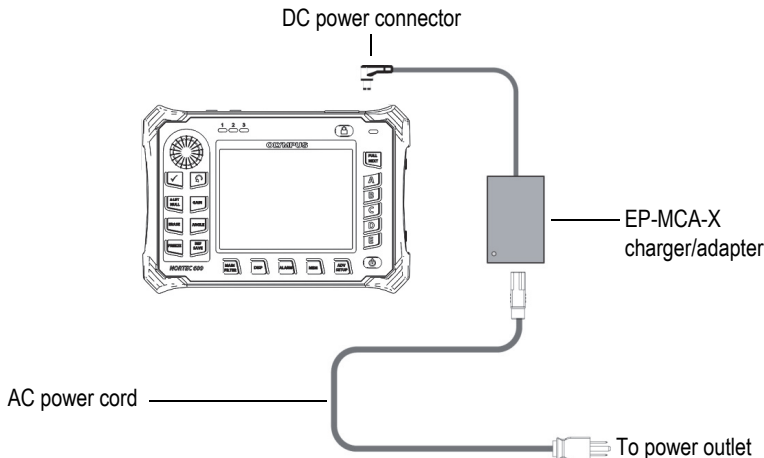
**Figure 1-8 Connecting the charger/adapter**

2. Lift the rubber seal that covers the DC connector on top of the NORTEC 600.
3. Connect the DC output power cable from the charger/adaptor to the DC power connector on top of the NORTEC 600 (see Figure 1-9 on page 35).

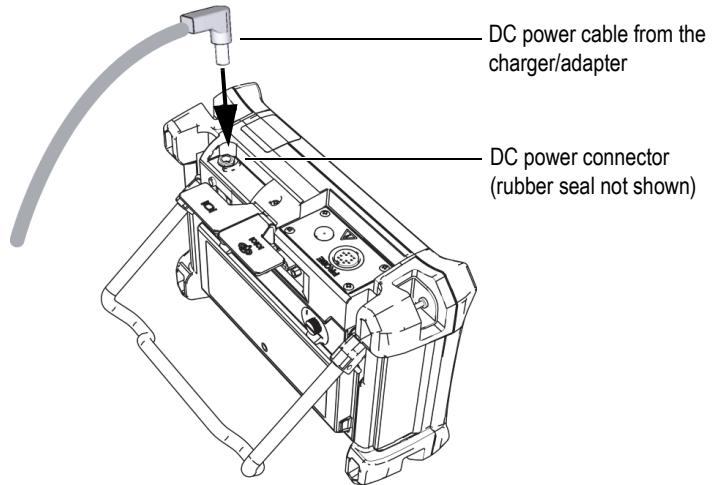

Figure 1-9 Connecting the DC power cable

Table 1 on page 35 explains the indicators for the power status of the charger/adaptor and the battery charge condition, which are visible at the top of the front panel and in the user interface.

Table 1 Charger/adaptor and battery indicators



Charger/adaptor indicator light	AC line power connected	Indicator meaning	Battery indicator
Red	Yes	Internal battery is charging.	
Off	No	Charger/adaptor is not connected.	

Table 1 Charger/adapter and battery indicators (continued)

Charger/adapter indicator light	AC line power connected	Indicator meaning	Battery indicator
Green	Yes	Charger/adapter is connected, but no battery is installed. OR Internal battery is fully charged.	

1.4.2 Battery Compartment

The NORTEC 600 battery compartment cover allows you to quickly access the battery (or AA batteries in the alkaline battery holder) without the need for tools. Two thumb screws on the battery compartment cover secure it to the instrument case and ensure the compartment is sealed.

The battery compartment cover also has a small hole in the bottom center area that is covered on the inside by an environmentally sealed membrane vent. This vent is a safety feature that is required in the event that the instrument battery fails and emits gas. This vent must not be punctured.

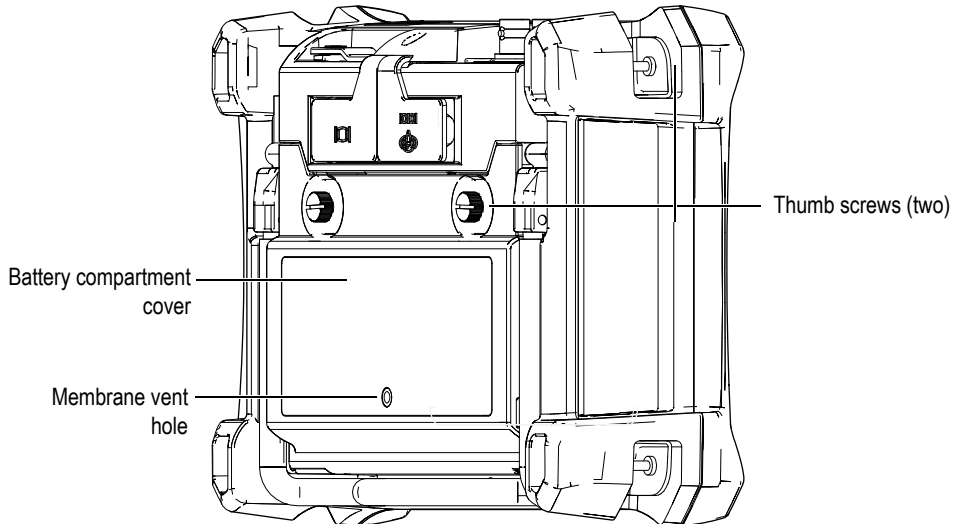
**Figure 1-10 The battery compartment**

The NORTEC 600 accepts one rechargeable lithium-ion battery pack (Evident P/N: 600-BAT-L-2 [U8760058]) that can be recharged inside the instrument or on the optional external charging base (Evident P/N: EPXT-EC-X [U8767043]). You can also use the NORTEC 600 with eight standard AA-size alkaline batteries installed in an alkaline battery holder (Evident P/N: 600-BAT-AA [U8780295]) for extended portable use.

**WARNING**

If the NORTEC 600 is to be used with a rechargeable battery, only use the Evident battery, P/N: 600-BAT-L-2 [U8760058]. Using any other type of battery might cause an explosion and injury.

1.4.3 Lithium-Ion Battery

The NORTEC 600 is normally used as a portable instrument powered by the lithium-ion battery and recharged via the charger/adaptor (both are supplied with the NORTEC 600). When properly maintained, and when the instrument is operated under typical inspection conditions, the lithium-ion battery should provide between 8 and 10 hours of continuous operation if a rotating scanner is not connected. If an Evident rotating scanner is connected, the NORTEC 600 should provide between 6 and 8 hours of continuous operation.

IMPORTANT

The lithium-ion battery is not fully charged when the instrument is shipped. You must charge the battery for two to three hours before using battery power to operate the instrument (see “Charger/Adapter” on page 33).

To install or replace the lithium-ion battery

1. Unfold the instrument stand (see Figure 1-11 on page 38).
2. At the back of the instrument, loosen the two thumb screws securing the battery compartment cover.
3. Remove the battery compartment cover.

4. Remove the battery and/or install the new battery in the battery compartment.
5. Check the cover gasket to make sure it is clean and in good condition.
6. Install the battery compartment cover at the back of the instrument, and then tighten the two thumb screws to complete the installation.

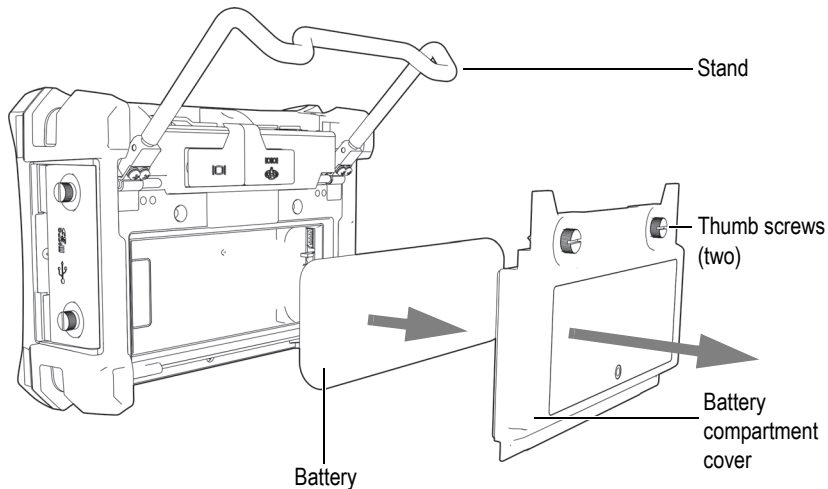

Figure 1-11 Removing the lithium-ion battery

1.4.4 Alkaline Batteries

The NORTEC 600 includes a battery holder (Evident P/N: 600-BAT-AA [U8780295]). This holder accommodates eight AA-size alkaline batteries for situations where an AC power source is not available and the internal Li-ion battery is discharged. When operated under typical inspection conditions, the alkaline batteries typically provide three hours of continuous operation.

To install the alkaline battery holder

1. Unfold the instrument stand (see Figure 1-12 on page 39).
2. Loosen the two thumb screws securing the battery compartment cover at the back of the instrument, and then remove the battery compartment cover.
3. Remove the lithium-ion battery, if installed.
4. Install eight AA-size alkaline batteries into the alkaline battery holder.
5. Connect the alkaline battery holder connector to the instrument.

6. Position the alkaline battery holder in the battery compartment.

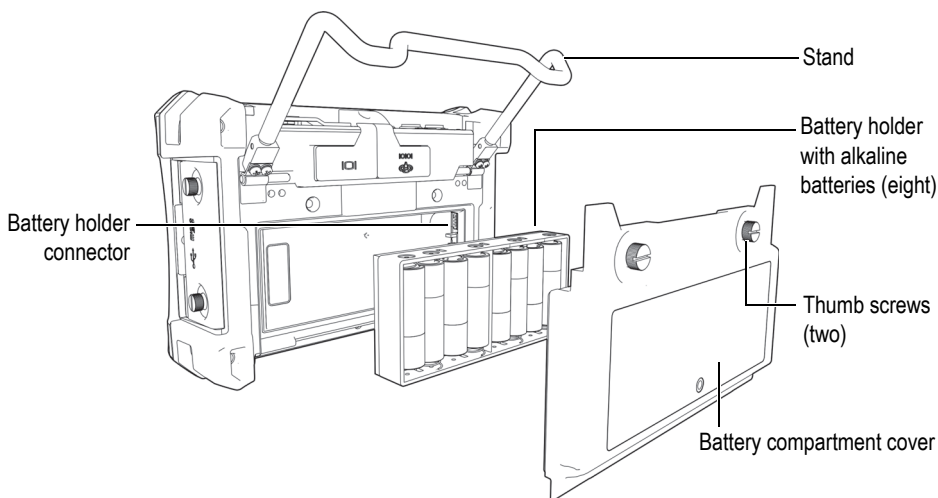

Figure 1-12 The alkaline battery holder

7. Install the battery compartment cover at the back of the instrument, and then tighten the two thumb screws.

NOTE

When alkaline batteries are installed in the instrument, the battery indicator in the user interface displays **ALK**. The charger/adaptor does not recharge the batteries installed in the alkaline battery holder.

1.5 Optional microSD Card Installation

A 2 GB microSD card (Evident P/N: MICROSD-ADP-2GB [U8779307]) can be installed in the NORTEC 600 instrument.

To install the microSD removable memory card

1. Remove the card from its packaging.

2. Loosen the two thumb screws, and then open the NORTEC 600 I/O door (see Figure 1-13 on page 40).

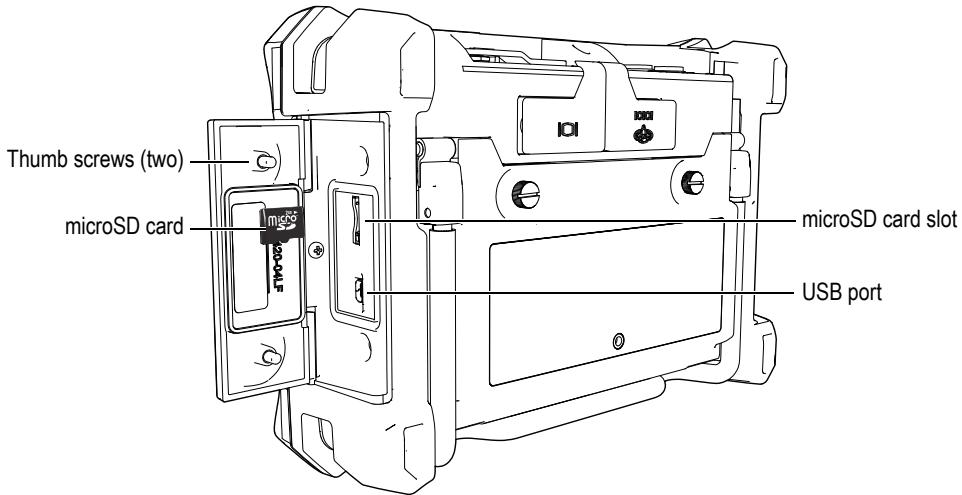

Figure 1-13 Installing the microSD card

3. Hold the card so that the microSD label faces toward the rear of the instrument.
4. Gently slide the card into the microSD slot until it clicks.

NOTE

To remove the microSD card, gently push the card into the instrument and release. A spring-loaded mechanism will partially eject the card, and then you can grasp the card and remove it from the instrument.

1.6 NORTEC 600 Hardware Features

The NORTEC 600 instrument has many physical features that are either completely new or improvements of features on older NORTEC 500 models. It is important to become familiar with the use and maintenance of these items.

1.6.1 Hardware Overview

Figure 1-14 on page 41 and Figure 1-15 on page 42 show the main components on the NORTEC 600 instrument.

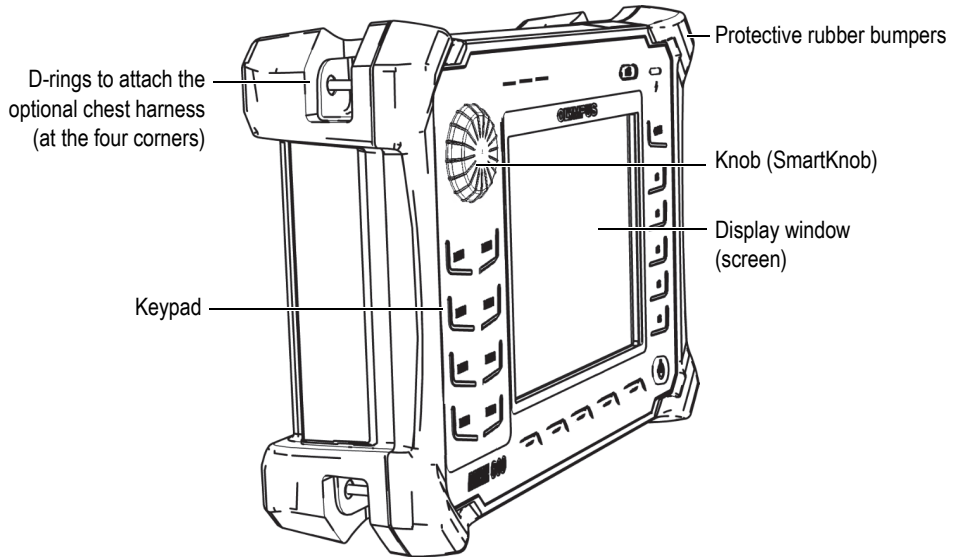

Figure 1-14 Overview of the NORTEC 600 hardware — Front view

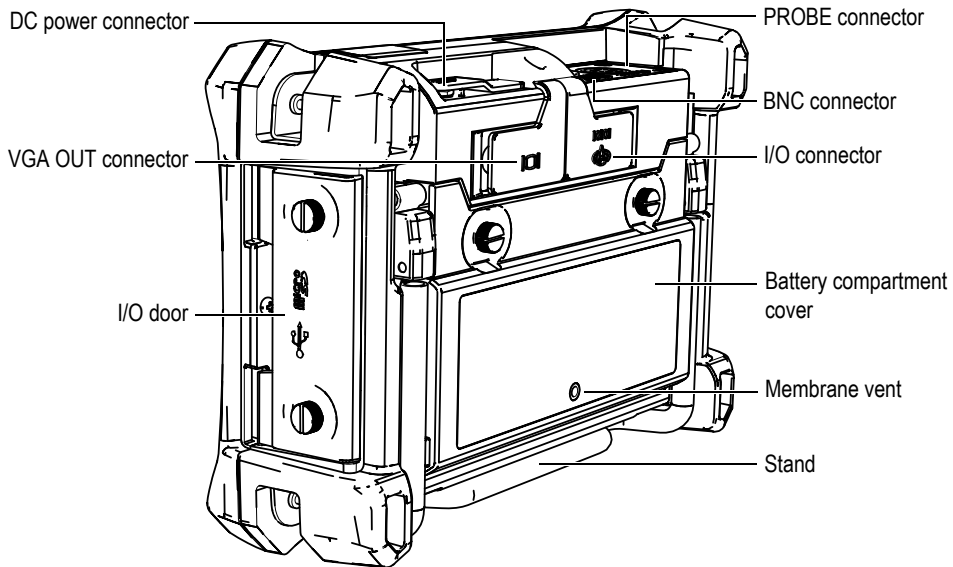

Figure 1-15 Overview of the NORTEC 600 hardware – Back view

1.6.1.1 Front Panel and SmartKnob

The SmartKnob is an important feature of the NORTEC 600 instrument, and it is the primary method used to change different parameters within a menu. In this manual, the term “knob” is also used to refer to the SmartKnob.

The NORTEC 600 front panel features direct-function keys that are used in combination with the SmartKnob to provide direct access to menus and common parameters, and to enable easy adjustment of values (see Figure 1-16 on page 43).

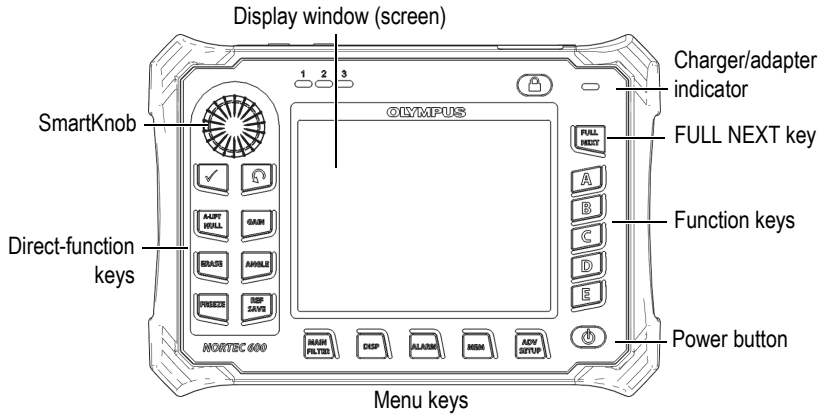

Figure 1-16 The NORTEC 600 front panel with SmartKnob and keypad

1.6.1.2 Keypad

The NORTEC 600 is available with an English, Chinese, Japanese, or international keypad configuration (see Figure 1-17 on page 44 to Figure 1-20 on page 45, and Table 2 on page 46). The text labels on some keys may be replaced by pictograms, depending on the keypad configuration. In this document, keys are referred to using the English label, which indicates its function. The keys are used to select menu items or screen parameters and to change parameter values.

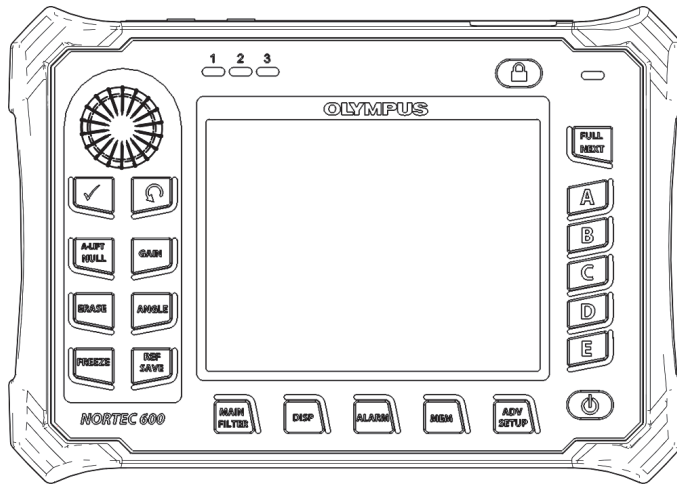

Figure 1-17 The NORTEC 600 English keypad

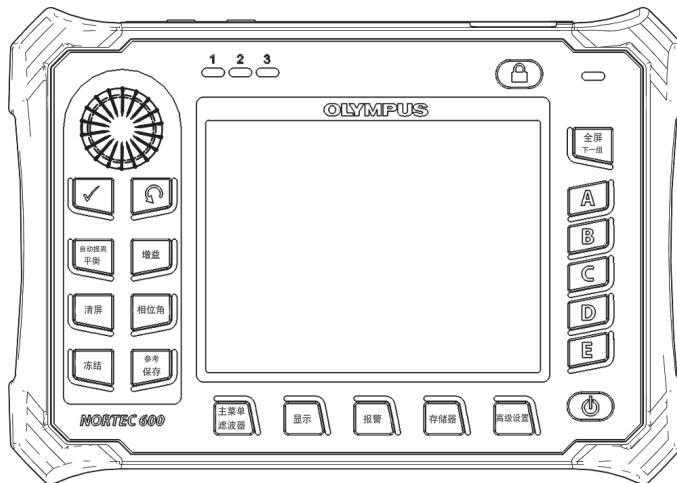

Figure 1-18 The NORTEC 600 Chinese keypad

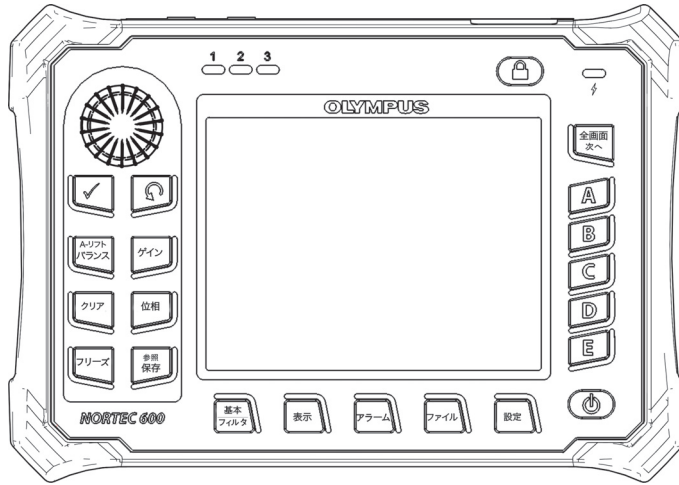

Figure 1-19 The NORTEC 600 Japanese keypad

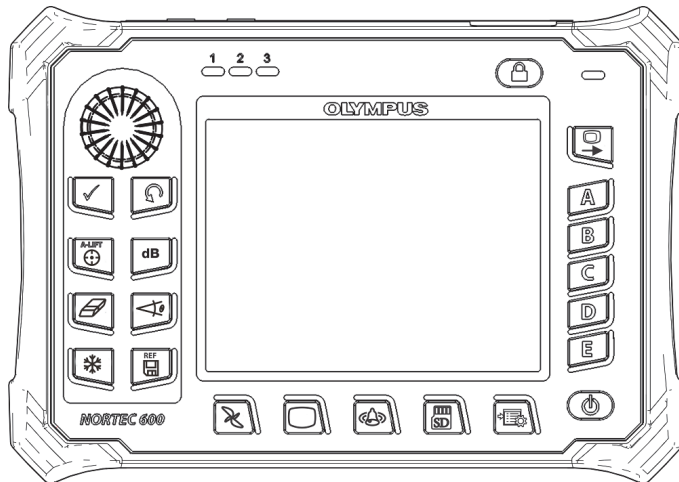

Figure 1-20 The NORTEC 600 international keypad

Table 2 Keypad functions













Function name	International keypad symbol	Function description
Enter		The Enter key is used to make selections.
Return		The Return (or Back) key is used to exit a menu and return to a previous screen.
A-LIFT NULL		If this direct-function key is pressed once, it nulls (zeros) the instrument. If this key is pressed and held, the Auto Liftoff is set.
GAIN	dB	Direct-function key used to display either the instrument's combined horizontal and vertical gain settings, horizontal gain only, or vertical gain only.
ERASE		Direct-function key used to erase the currently displayed image.
ANGLE		Direct-function key used to display the angle.
FREEZE		Direct-function key used to freeze the image displayed on the instrument for further evaluation. When the image is frozen, the NORTEC 600 also allows calibrating the eddy current signals, and changing the gains or angle.
REF SAVE		Direct-function key used to save images and settings in the instrument's memory. When this key is pressed once (and released), the currently displayed image and settings are saved. When this key is pressed and held, the current instrument image is set as the reference memory display.

Table 2 Keypad functions (*continued*)

Function name	International keypad symbol	Function description
MAIN FILTER		Provides access to the main menu, which controls functions such as frequency, gain, angle, and filters.
DISP		Provides access to the display menu, which controls functions such as display mode, position, trace, and grid.
ALARM		Provides access to the alarm menu, which controls functions such as alarm type, dwell time, horn volume, and alarm position.
MEM		Provides access to the memory menu, which controls functions such as previewing stored memory files, recalling and editing stored files, capture mode, capture time, and user information.
ADV SETUP		Provides access to the instrument's advanced settings, including the application selection menu, the ALL SETTINGS menu, frequency mode, colors, password, systems setup, reset, unlock options, and legal/regulatory information.
FULL NEXT		Used to expand the instrument display to full screen, or to select items in the menu.
A	A	Function key
B	B	Function key
C	C	Function key
D	D	Function key
E	E	Function key

1.6.2 Connectors

The NORTEC 600 instrument contains several types of connectors for hardware components.

1.6.2.1 Probe and BNC Connectors

The NORTEC 600 instrument is supplied with a 16-pin LEMO (PROBE) connector and a BNC connector.

The PROBE (LEMO) and BNC connectors are located at the top of the instrument, on the left-hand side. The two connectors are easily accessible from the front of the instrument (see Figure 1-21 on page 48).

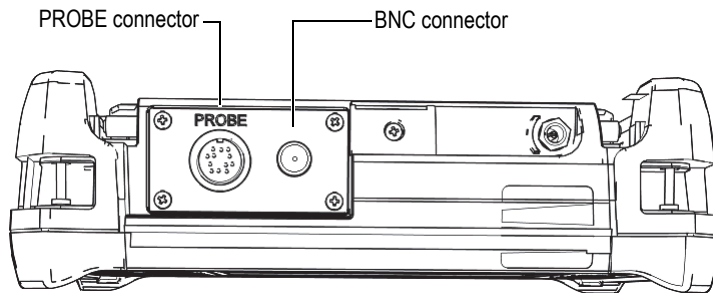

Figure 1-21 Location of the PROBE (LEMO) and BNC connectors



CAUTION

Do not allow metallic or foreign objects to enter the device through connectors or any other openings. Otherwise, an electric shock or malfunction may result.

1.6.2.2 Input/Output (I/O) and VGA OUT Connectors

The I/O and the VGA OUT connectors are located at the back of the instrument, in the upper section (see Figure 1-22 on page 49). A rubber cover protects each connector.

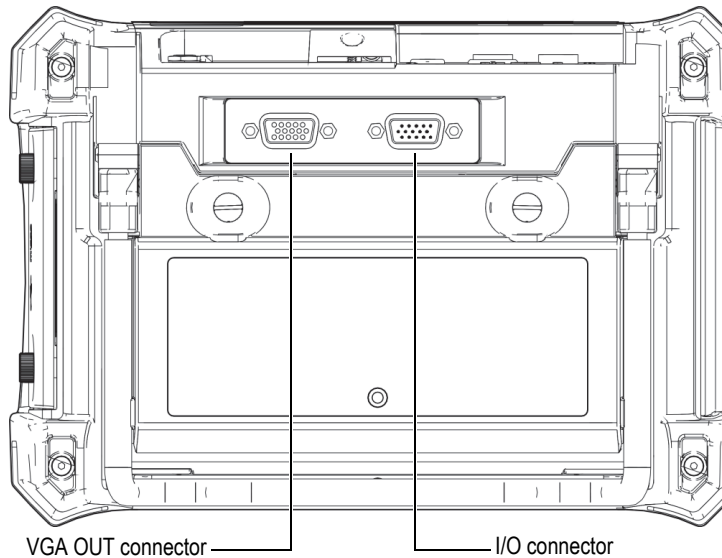

Figure 1-22 The VGA OUT and I/O connectors

The VGA OUT connector allows the user to connect the instrument to a standard analog computer monitor. The I/O connector is used to connect an external horn or, if necessary, to connect an external control for integrating the NORTEC 600 into a system. For PC communication details, see “microSD and USB Port” on page 50.



CAUTION

Do not expose the instrument to harsh and wet environments while the I/O or the VGA OUT connectors are not protected by their rubber covers. To prevent connector corrosion and damage to the instrument, keep the rubber protective covers on the connectors when no cable is connected.

1.6.2.3 microSD and USB Port

On the right-hand side of the NORTEC 600, a door covers the microSD slot and the USB port (see Figure 1-23 on page 50). The I/O door closes against an integral membrane seal to keep liquids away from the unsealed connectors behind the door.

The NORTEC 600 utilizes 2 GB microSD memory cards for both onboard and removable memory. The onboard 2 GB microSD card is mounted on the PC board inside the instrument, and is responsible for all onboard data storage. In the event the instrument is damaged beyond repair, this microSD card can be removed at an authorized service center, allowing you to recover critical data from the damaged instrument.

The NORTEC 600 allows the user to connect the instrument to a PC via the USB port. PC communication requires the interface program (Evident P/N: N600-CD [U8030151]) provided with the instrument for file transfers. The NORTEC 600 can also communicate directly with other SPC programs.

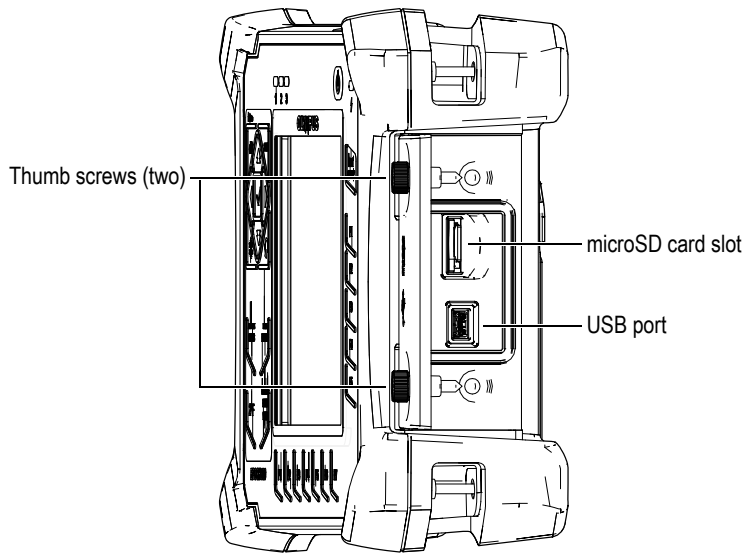

Figure 1-23 The microSD slot and USB port

The I/O door is kept closed by two thumb screws. You can also use a coin or a screwdriver to manipulate these thumb screws as needed.

**CAUTION**

Do not expose the instrument to harsh and wet environments while the I/O door is open. To prevent connector corrosion and damage to the instrument, keep the I/O door closed and sealed when no cable is connected.

1.6.3 Various Hardware Features

The NORTEC 600 instrument's physical features make it suitable for a variety of operating environments.

1.6.3.1 Instrument Stand

The NORTEC 600 features an articulating stand for variable viewing angles (see Figure 1-24 on page 51). The stand is attached to the back of the instrument with two hard pivot blocks. There is a high-friction coating on the stand surface to help prevent it from sliding. The stand is bent in the center to easily accommodate being placed on a curved surface.

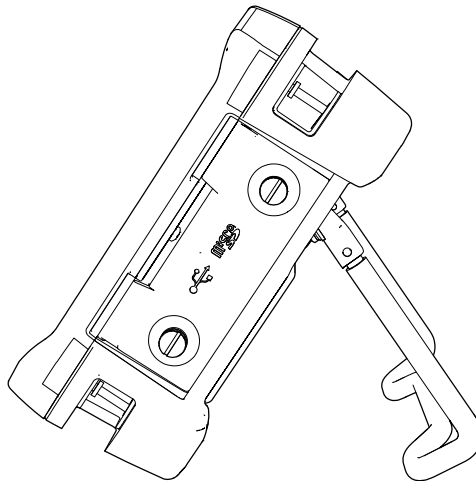

Figure 1-24 Instrument stand

1.6.3.2 O-Ring Gasket and Membrane Seals

The NORTEC 600 contains seals that protect the instrument's internal hardware from the environment:

- Battery compartment cover seal
- I/O door seal
- Membrane vent

These seals must be properly maintained to assure environmental durability. Instrument seals are evaluated and replaced as needed during the instrument annual calibration. This should be performed at an authorized Evident service center.

1.6.3.3 Display Protection

The NORTEC 600 includes a clear plastic sheet protecting the instrument display window. Evident strongly recommends leaving this protection sheet in place. Replacements are available in packages of ten sheets (Evident P/N: 600-DP [U8780297]).



CAUTION

The display window is permanently bonded to the instrument case to fully seal the instrument. If the display window becomes damaged, the front part of the case must be replaced, along with the instrument's keypad.

1.6.4 Environmental Ratings

The NORTEC 600 is an extremely rugged and durable instrument that can be used in harsh environments. To classify the instrument's durability in wet or damp environments, Evident has adopted the IP (ingress protection) system to rate how well the instrument is sealed.

The NORTEC 600 is designed and manufactured to meet the requirements of the IP66 ingress protection rating. To maintain this level of protection, you are responsible for the proper care of all routinely exposed membrane seals. Additionally, you are responsible for returning the instrument to an authorized Evident service center each year to ensure that the instrument seals are properly maintained. Evident cannot

guarantee any level of ingress protection performance once the instrument seals have been manipulated. You must use sound judgment and take proper precautions before exposing the instrument to harsh environments.

The NORTEC 600 adheres to the environmental standards listed in Table 6 on page 339.

2. Software User Interface

This chapter explains the main software screens and menus on the NORTEC 600 instrument. The back of the NORTEC 600 contains a quick guide to the instrument keypad and functions (see Figure 2-1 on page 55).

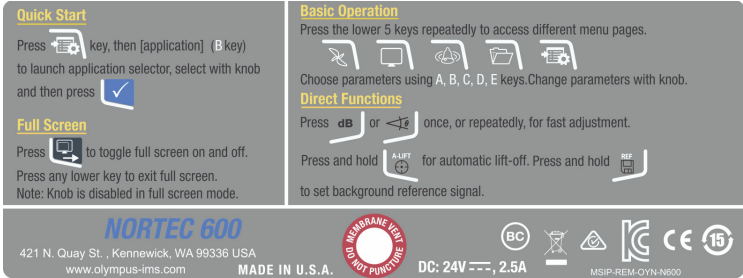

Figure 2-1 The instrument label showing keypad functions

2.1 Starting Up the Instrument

When power is turned on, the NORTEC 600 starts up in one of two modes, depending on what is connected to the instrument.

If no probe is connected, or if a probe that is not a PowerLink type of probe is connected, the first screen displayed by the NORTEC 600 software is the application quick-setup menu (see Figure 2-2 on page 56). Choose from among the basic applications on this menu to automatically configure the appropriate instruments settings. For more details on the application quick-setup menu, see “Common NORTEC 600 Applications” on page 126.

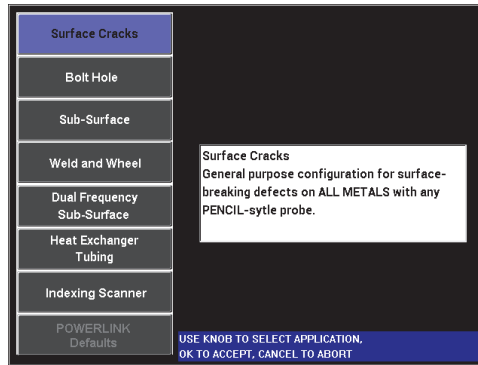

Figure 2-2 Application choices on the quick-setup menu

NOTE

The NORTEC 600 applications are designed for quick setup of the instrument. However, always follow published maintenance procedures when inspecting.

2.1.1 Navigating the Application Menu

Navigating the menu is designed to be intuitive, and the settings for each application will permit immediate inspection; little or no additional instrument setup is needed.

To navigate the application menu

1. Rotate the knob to highlight one of the eight applications.
2. Press the Enter key (✓) to select the application.

OR

Press the Return key (↻) to go back to the NORTEC 600 main screen.

Alternatively, if a PowerLink probe is connected to the instrument when it is turned on, the NORTEC 600 starts up in the PowerLink recognition screen (see Figure 2-3 on page 57).

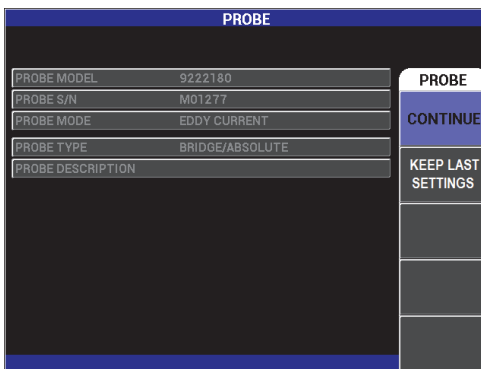

Figure 2-3 The PowerLink recognition screen

To navigate the application menu for PowerLink

- ◆ In the PowerLink recognition screen, load the program stored in the PowerLink probe by pressing the A key.
You can use the **KEEP LAST SETTINGS** function to load the previous parameters if they are compatible with the probe or accessory that is detected. This automatically sets up the instrument.

OR

- ◆ Bypass the stored program in the probe and gain access to the instrument's main inspection screen by pressing the Return key (↵).

2.1.2 Main Inspection Screen

After the initial steps are completed through the quick-setup menu or PowerLink menu, the main inspection screen is displayed (see Figure 2-4 on page 58).

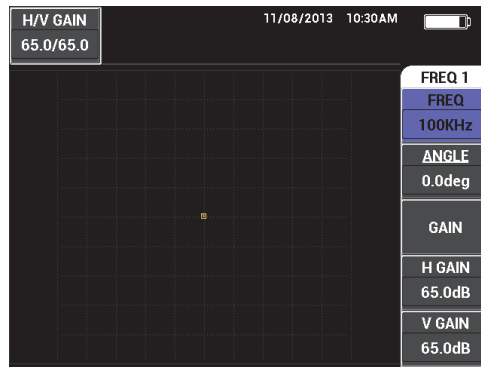



Figure 2-4 The main inspection screen

The battery power indicator remains visible at the top of the screen, except when in full-screen mode (see Table 1 on page 35 for details). The time and date also remain visible, except when in full-screen mode.

The rectangular readout in the top-left corner of the screen is called the quick-access bar (see Figure 2-5 on page 59). It displays either the instrument combined horizontal and vertical gain settings, horizontal gain only, vertical gain only, or angle setting when the GAIN (**dB**) or ANGLE () direct-function keys are pressed. The quick-access bar remains visible until any other key is pressed.

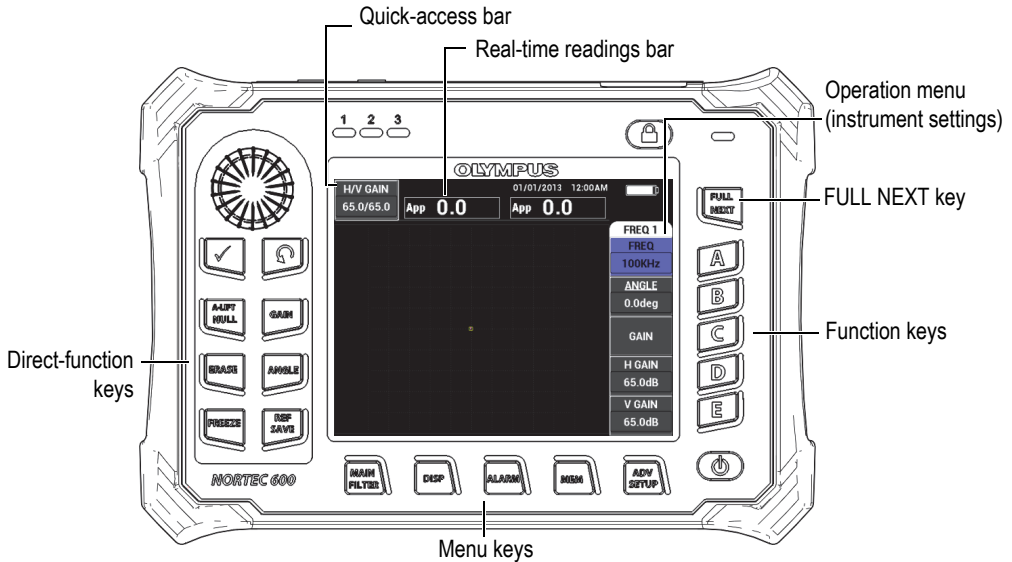







Figure 2-5 The NORTEC 600 front panel and main inspection screen





The real-time readings bar displays user-configurable readings (measurements) [see Figure 2-5 on page 59]. It can display a maximum of two real-time readings from among the available choices. The real-time readings bar can be set to display one or two readings, or it can be disabled. For more information, see “Displaying Real-Time Readings” on page 62.

The instrument settings are displayed on the right hand side of the main screen. The displayed settings information can change, depending on the menu key that is pressed. The menu keys are the five keys located at the bottom of the front panel:





MAIN FILTER (), DISP (), ALARM (), MEM (), and ADV SETUP (), as shown in Figure 2-5 on page 59.

The microSD memory card can be inserted into a slot that is located behind the I/O door on the right-hand side of the instrument (see Figure 1-23 on page 50). Depending on the context and on the available functions and options, various indicators and numeric values appear on the screen and around the main measurement value (see Figure 2-5 on page 59).

2.2 Selecting from the Menus

The NORTEC 600 menu keys at the bottom of the front panel are MAIN FILTER () , DISP () , ALARM () , MEM () , and ADV SETUP () . These keys provide access to the operation menu. This menu appears at the right-hand side of the screen (see Figure 2-5 on page 59). If applicable, pressing a menu key again will display a secondary menu with parameters available for that key.

To select from a menu

1. Press one of the menu keys located at the bottom of the front panel to display a menu: MAIN FILTER () , DISP () , ALARM () , MEM () , or ADV SETUP () .

Pressing the same menu key again will cycle through the available options and update the available functions which can then be adjusted.

2. Select the function to be changed by pressing the function key (A, B, C, D, or E) located next to the function, which highlights the selected function.

Rotating the knob changes the function's value. The value selected with the knob is automatically entered.

2.3 Displaying All Functions Simultaneously — ALL SETTINGS Menu

As an alternative to the operation menu, the NORTEC 600 has the option of displaying all functions simultaneously using the **ALL SETTINGS** menu. The **ALL SETTINGS** menu consists of three main elements: the title bar, the parameters, and the help text (see Figure 2-6 on page 61).

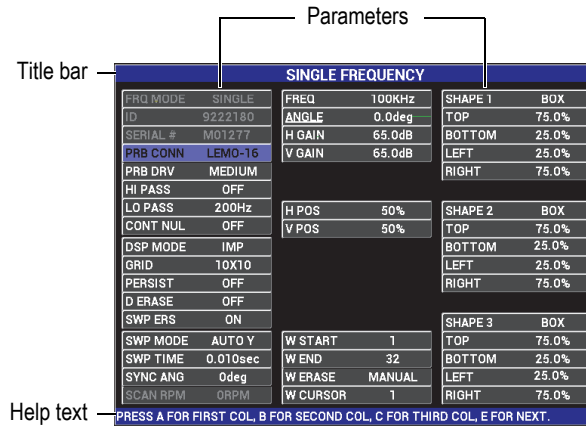







Figure 2-6 The ALL SETTINGS menu

2.3.1 Using the ALL SETTINGS Menu

The ALL SETTINGS menu is accessed through the ADV SETUP menu key ()

To use the ALL SETTINGS menu

1. Press the ADV SETUP menu key (.
 2. Press the B key.
 3. Press the FULL NEXT key () to select the parameter to be adjusted.
 4. Rotate the knob to select the desired value.
 5. Press the FULL NEXT key () to select additional parameters to be adjusted.
- OR

Press  to exit the menu and return to the previous screen.

NOTE

Because of the large number of functions that are available on the NORTEC 600 instrument, the **ALL SETTINGS** menu contains multiple screens, or pages. The help text at the bottom of the menu provides any additional navigation options that may be needed.

2.3.2 Special Functions in the ALL SETTINGS Menu

Two special instrument functions are found only in the **ALL SETTINGS** menu: **EXT HORN** (external horn) and **AOUT PWR** (analog out power). These functions control the power or enable the output connectors on the back of the instrument (see Figure 1-22 on page 49). To enable these functions, follow the instructions in “Using the ALL SETTINGS Menu” on page 61.

NOTE

If the NORTEC 600 instrument is being used in noisy conditions, an external horn can be used. The horn connects to the I/O connector on the back of the instrument and increases the audible alarm’s sound output to 70 dB (see Table 10 on page 348 for the part specification).

2.4 Displaying Real-Time Readings

The real-time readings bar displays user-configurable readings (measurements) [see Figure 2-5 on page 59]. It can display a maximum of two real-time readings from among seven available choices. The real-time readings bar can be set to display one or two readings, or it can be disabled.

The following readings can be displayed (see Figure 2-7 on page 63 through Figure 2-11 on page 65):

- **OFF**
- **APP** — Maximum amplitude vector, peak-to-peak (P-P)
- **VPP** — Maximum vertical voltage, peak-to-peak

- **HPP** – Maximum horizontal voltage, peak-to-peak
- **VMAX** – Maximum vertical voltage from extended null line
- **HMAX** – Maximum horizontal voltage from extended null line
- **DEG PP** – Angle of **VMAX**, peak-to-peak

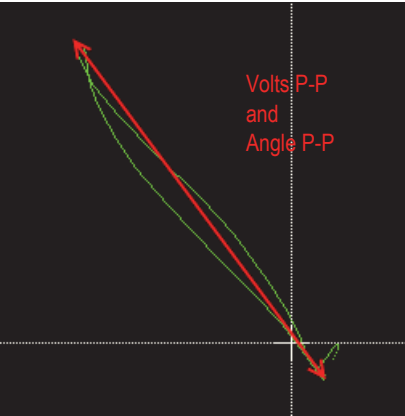

Figure 2-7 Example of VPP and DEG PP

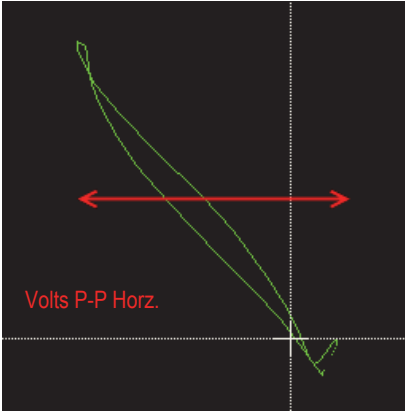

Figure 2-8 Example of HPP

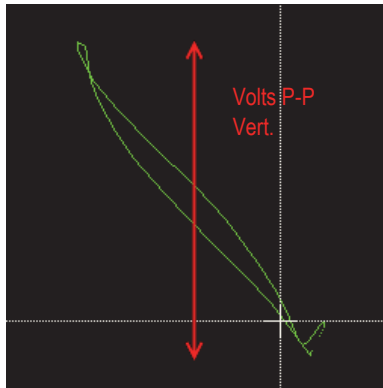

Figure 2-9 Example of VPP

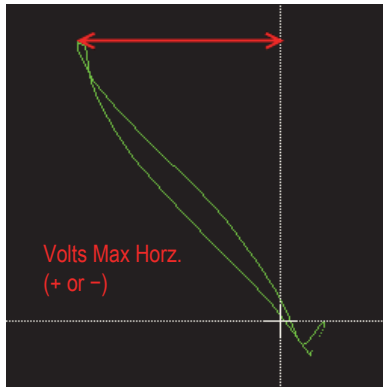

Figure 2-10 Example of HMAX

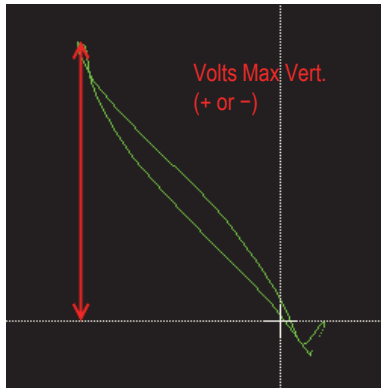





Figure 2-11 Example of VMAX

2.4.1 Enabling Real-Time Readings on the Main Inspection Screen

The real-time readings are enabled through the ADV SETUP menu key ()

To enable the real-time readings bar on the main inspection screen

1. Press the ADV SETUP menu key ()
2. Press the B key.
3. Press the E key.
4. Press the B key.
5. Press the FULL NEXT key () to navigate to the desired type and/or location.

NOTE

Only **TOP LEFT** and **TOP RIGHT** are valid locations for the real-time readings on the main inspection screen. For available locations in full screen, see “Enabling the Real-Time Readings in Full-Screen Mode – FULL NEXT key” on page 66.

6. Rotate the knob to make a selection.
7. Press the FULL NEXT key () to navigate to another type and/or location.

OR

Press the Return key () to exit.

2.4.2 Enabling the Real-Time Readings in Full-Screen Mode — FULL NEXT key



The real-time readings are also available in full-screen mode, which can be accessed using the FULL NEXT key () shown in Figure 2-5 on page 59. The location of displayed readings on full screen differs from the location on the main inspection screen, and readings are user-selectable.

Valid (possible) locations for the real-time readings in full-screen mode are: **TOP LEFT**, **TOP CNTR** (top center), **TOP RIGHT**, **BOT LEFT** (bottom left), **BOT CNTR** (bottom center) or **BOT RGHT** (bottom right).

NOTE

The performance and results of the real-time readings are greatly affected by the **D ERASE** (display erase) and **PERSIST** (persistence) settings. It is recommended to experiment with these parameters. For details on making changes to these settings, see “D ERASE (display erase)” on page 95 and “PERSIST (variable persistence)” on page 95.

To enable the real-time readings in full-screen mode (FULL NEXT key)

1. Press the ADV SETUP menu key (.
 2. Press the B key.
 3. Press the E key.
 4. Press the B key.
 5. Press the FULL NEXT key () to navigate to the desired type and/or location.
 6. Rotate the knob to make a selection.
 7. Press the FULL NEXT key () to navigate to another type and/or location.
- OR

Press the Return key () to exit.

3. Initial Setup

This chapter contains the basic configurations for the NORTEC 600 instrument.

3.1 Setting the User Interface Language and the Decimal Symbol

You can configure the NORTEC 600 instrument to present the user interface in the following languages: English, French, Spanish, German, Japanese, Chinese, Russian, Swedish, Italian, Portuguese, Norwegian, Hungarian, Polish, Dutch, and Czech. You can also change the character that represents the decimal of a number.

To change the user interface language and the decimal symbol

1. Press the ADV SETUP menu key () twice, and then press the B key to access the **SYSTEM SETUP** screen (see Figure 3-1 on page 69).

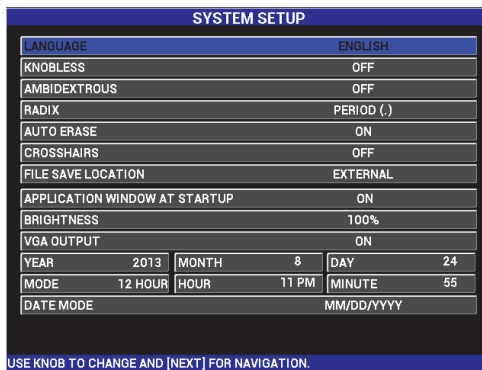







Figure 3-1 The SYSTEM SETUP screen

2. In the **SYSTEM SETUP** screen, press the FULL NEXT key () until **LANGUAGE** is highlighted.
3. Using the knob, select the desired language.
4. Repeatedly press the FULL NEXT key () until **RADIX** is highlighted.
5. Using the knob, select the desired character to represent the decimal of numbers: **PERIOD (.)** or **COMMA (,)**.
6. Press  to return to the previous screen.

3.2 Setting the Clock

The NORTEC 600 has a built-in date and time clock. You can set the date and the time, and select their respective format. The NORTEC 600 saves all inspection results with their acquisition date.



To set the clock

1. Press the ADV SETUP menu key () twice, and then press the B key to access the **SYSTEM SETUP** screen (see Figure 3-1 on page 69).
2. Set the **YEAR, MONTH, DAY, MODE (12 HOUR or 24 HOUR), HOUR, MINUTE,** and **DATE MODE** as follows:
 - a) Repeatedly press the FULL NEXT key () until the item (**YEAR, MONTH, DAY,** etc.) is highlighted.
 - b) Rotate the knob until the correct value is displayed.
3. Press  to return to the previous screen.

3.3 Changing the Location of Saved Files

Files can be saved on the internal or external (accessible) microSD card.

To change the location of saved files

1. Press the ADV SETUP menu key () twice, and then press the B key to access the **SYSTEM SETUP** screen (see Figure 3-1 on page 69).
2. Repeatedly press the FULL NEXT key () until **FILE SAVE LOCATION** is highlighted.
3. Change the location as required; for example, select **EXTERNAL** if you want to save files on the external microSD card.



NOTE

The **BACKUP / RESTORE** function is disabled when files are saved on the external microSD card.

3.4 Changing the Display Settings

You can change the appearance of some display elements such as brightness, auto erase, VGA output, and whether or not the application window displays at startup.

To change the display settings

1. Press the ADV SETUP menu key () twice.
2. Press the B key to access the **SYSTEM SETUP** screen.
3. In the **SYSTEMS SETUP** screen (see Figure 3-1 on page 69), use the FULL NEXT key () to highlight the desired parameter and then use the knob to change its value:
 - a) Set **BRIGHTNESS** to one of the predefined brightness levels: **0 %**, **25 %**, **50 %**, **75 %**, or **100 %** (see “Changing the Display Brightness” on page 72 for details).
 - b) Set **VGA OUTPUT** to **ON** or **OFF**.

NOTE



An external display can be used if the **VGA OUTPUT** is set to **ON**, which enables the VGA output connector on the back of the NORTEC 600 instrument. By default, this setting is **OFF**.

- c) Set **AUTO ERASE** to **ON** or **OFF** (see “Adjusting Auto Erase” on page 73 for details).
 - d) Set **APPLICATION WINDOW AT STARTUP** to **ON** or **OFF** (see “Selecting the Startup Screen” on page 73 for details).
 - e) Set **CROSSHAIRS** to **ON** or **OFF**.
If **ON** is selected, a cross mark, centered on the null position, or point, is displayed. This is useful for monitoring signal drift from the null point.
4. Press  to return to the previous screen.

3.5 Changing the Display Brightness

You can adjust the NORTEC 600 display brightness by changing the backlight intensity. The display brightness can be set at 0 %, 25 %, 50 %, 75 %, and 100 %. Choosing a high percentage increases the brightness of the display. By default, the display brightness is set to 100 %. The NORTEC 600 uses a transfective color display that reflects ambient light and becomes brighter in direct light. With brighter ambient conditions, you can set the display **BRIGHTNESS** to a lower percentage.

To change the display brightness

1. Press the ADV SETUP menu key () twice, then press the B key to enter the **SYSTEM SETUP** screen.
2. Repeatedly press the FULL NEXT key () until **BRIGHTNESS** is highlighted.
3. Using the knob, select the desired **BRIGHTNESS** percentage: **0 %**, **25 %**, **50 %**, **75 %**, or **100 %**.
4. Press  to return to the main inspection screen.



NOTE

Reducing the display **BRIGHTNESS** percentage increases the battery life. Battery life specifications are based on backlight **BRIGHTNESS** set to **50 %**.

3.6 Adjusting Auto Erase

You can adjust the NORTEC 600 to clear (erase) the screen contents automatically after the NULL key is pressed. By default, the **AUTO ERASE** function is set to **ON**, but it can be disabled by selecting **OFF**.

To adjust Auto Erase



1. Press the ADV SETUP menu key () twice, then press the B key to enter the **SYSTEM SETUP** screen.
2. Repeatedly press the FULL NEXT key () until **AUTO ERASE** is highlighted.
3. Use the knob to disable the function (select **OFF**) or enable the function (select **ON**).
4. Press  to return to the previous screen.

3.7 Selecting the Startup Screen

You can adjust the NORTEC 600 to display the **APPLICATION SELECTION** screen automatically after it is turned on. This function can also be disabled, so that the instrument will instead display the main inspection screen. By default, the **APPLICATION WINDOW AT STARTUP** function is set to **ON**.

To select the startup screen

1. Press the ADV SETUP menu key () twice, then press the B key to enter the **SYSTEM SETUP** screen.



2. Repeatedly press the FULL NEXT key () until **APPLICATION WINDOW AT STARTUP** is highlighted.
3. Use the knob to disable the function (select **OFF**) or enable the function (select **ON**).
4. Press  to return to the main inspection screen.

3.8 Enabling Knobless Entry for Harsh Environments

The knobless function allows the NORTEC 600 to be used in radioactive or harsh environments where the instrument has to be put inside a bag, which makes it difficult to use the knob.

If the knobless entry function is enabled, the frequency, angle, and the combined horizontal and vertical gain settings can be increased or decreased using keypad entries instead of the knob. The knobless entry function is enabled using the **SYSTEM SETUP** menu. By default, the knobless entry function is set to **OFF**. For more information on knobless entry, see “Knobless Entry” on page 84.

To enable the knobless entry function

1. Press the ADV SETUP menu key () twice, then press the B key to enter the **SYSTEM SETUP** screen.
2. Repeatedly press the FULL NEXT key () until **KNOBLESS** is highlighted.
3. Use the knob to disable the function (select **OFF**) or enable the function (select **ON**).
4. Press  to return to the previous screen.

4. Control Functions

This chapter provides explanations of the NORTEC 600 instrument control functions.

4.1 PowerLink

The PowerLink feature enables the NORTEC 600 eddy current instrument to automatically recognize Evident PowerLink probes and rotating scanners when they are connected to the instrument. The instrument is then configured according to the parameters programmed into the PowerLink ID chip. Each PowerLink probe is programmed at the factory to identify itself based on the model number, preselected operating frequency, gain, and serial number.

When a PowerLink probe or rotating scanner is connected, the instrument displays the PowerLink recognition screen (see Figure 4-1 on page 75).

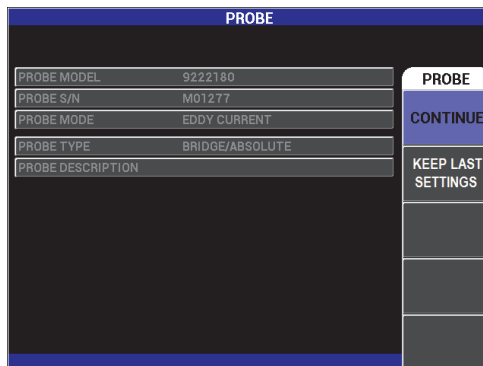



Figure 4-1 The PowerLink recognition screen

At this point, if the PowerLink function has been enabled, the settings from the probe or rotating scanner will be loaded into the NORTEC 600 instrument. If the PowerLink function has been disabled, this screen will be bypassed. In either case, the instrument will next proceed to the main inspection screen.

If you turn on the instrument with a connected PowerLink probe or rotating scanner, press the A key to use the PowerLink feature, or press  to proceed without using the PowerLink feature. The **KEEP LAST SETTINGS** function lets you load the previous parameters if they are compatible with the probe or accessory that is detected.

4.2 Instrument Controls

The NORTEC 600 instrument controls are displayed in Figure 4-2 on page 76.

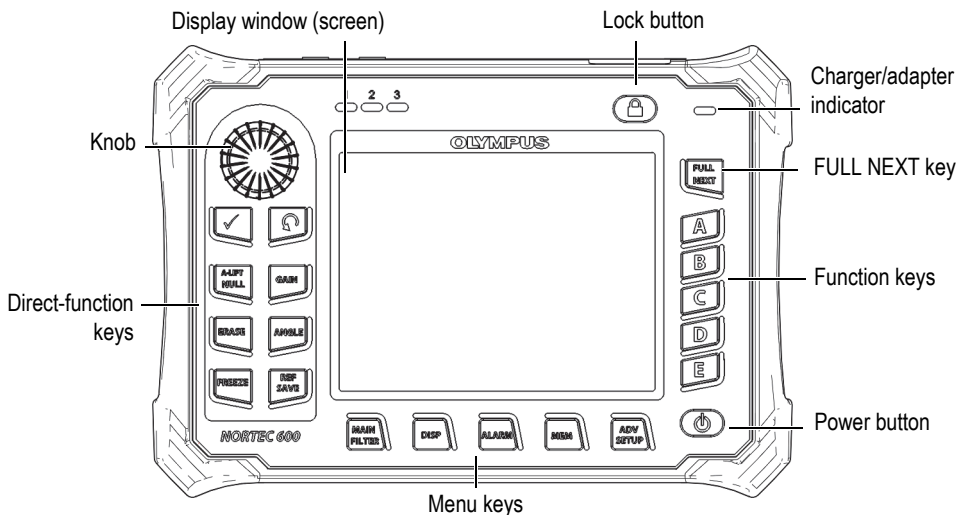



Figure 4-2 The NORTEC 600 instrument controls



4.2.1 Display

The NORTEC 600 instrument is configured with a color liquid crystal display (LCD) and offers 640 × 480 resolution (full VGA). The LCD display, also referred to as a screen, shows the eddy current signal, menus, status bar, messages, and full screen text when required. Several display modes are available (see “Display Menu – DISP Key” on page 93).

4.2.2 Power and Lock Buttons

The power button () toggles the instrument power on and off. At startup, the instrument will normally attempt to restore its last configuration.



The instrument lock can be enabled or disabled by pressing the lock button (). When activated, the lock disables most of the instrument function keys, menu keys, and the knob. This prevents inadvertent key entries after the instrument is calibrated and ready to proceed with inspections.

When the lock is activated, an indicator light () illuminates below the battery life indicator at the upper right side of the instrument screen, and only the NULL, ERASE () , and ANGLE () direct-function keys remain functional.

NOTE

When the instrument lock is enabled, the knob is available after the ANGLE direct-function key () is pressed.

4.2.3 Direct-Function Keys

The direct-function keys located on the left side of the instrument are used to directly select the instrument settings that are most often used for adjustment. Three of the direct-function keys—A-LIFT NULL ()^{A-LIFT}, FREEZE () , and REF SAVE ()^{REF}—have more than one main function.

A-LIFT NULL ()

The primary function of the A-LIFT NULL key () is to “null”, or initialize to zero, the instrument screen. The secondary function of this key is to enable the **A-LIFT** (Auto Liftoff) function, which automatically sets the probe liftoff from left to right (horizontally).

To enable A-LIFT (Auto Liftoff)

NOTE

The steps that follow assume that the following criteria have been met:

- A probe is connected to the NORTEC 600 instrument.
- The probe has been “nulled” normally.
- The liftoff is not horizontal (see Figure 4-3 on page 79).
- The probe is in contact with the reference standard.

-
1. Press and hold the A-LIFT NULL direct-function key () until a “beep” sound signal is heard (approximately 3 seconds) and the text “**LIFT PROBE**” is displayed on the instrument screen (see Figure 4-4 on page 79).
 2. After the sound signal and **LIFT PROBE** message, lift the probe off the reference standard.
The instrument calculates the change required to correct the instrument **ANGLE** setting.
 3. Null the probe again.
The probe liftoff should resemble the image shown in Figure 4-5 on page 80.

NOTE

The accuracy of Auto Liftoff depends on factors such the angle at which the probe was lifted off the reference standard, and the material condition. Results may vary, and minor adjustments using the **ANGLE** direct-function key () may still be necessary.

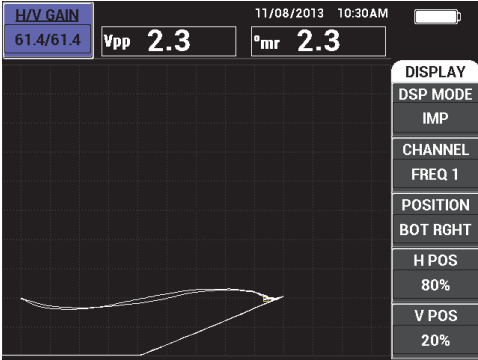

Figure 4-3 Probe liftoff—initially not horizontal

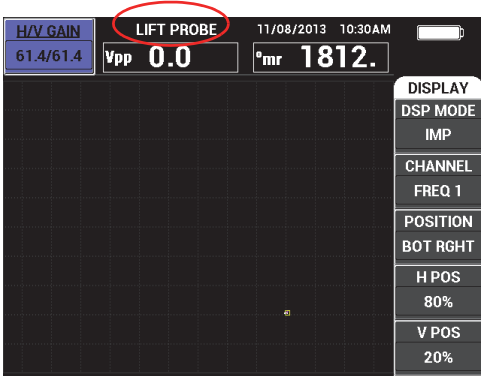

Figure 4-4 The LIFT PROBE message after holding the A-LIFT NULL key

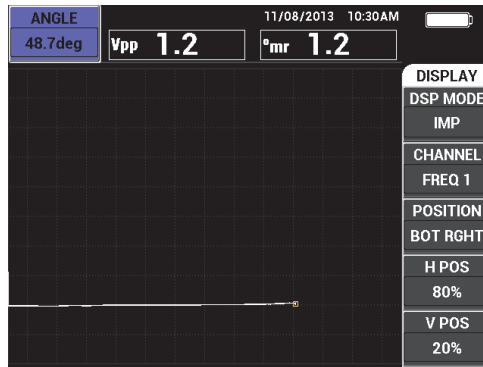







Figure 4-5 Probe liftoff after nulling

ERASE ()

Provides the ability to erase the instrument screen instantly; this key does not have a secondary function.

FREEZE ()

The primary function of the FREEZE key () is to freeze the current image on the instrument screen for further evaluation. When the FREEZE key () is pressed, the data acquisition stops and an indicator (capital letter “F”) is displayed on the instrument screen below the battery charge indicator (see Figure 4-6 on page 81). When FREEZE is active, the functionality of the A-LIFT NULL key () and ERASE key () is disabled, and a “beep” sound signal is emitted if either of these keys is pressed.

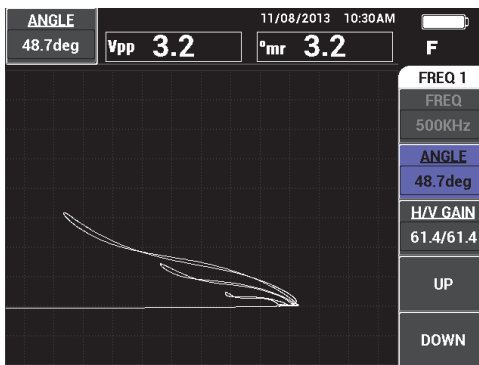



Figure 4-6 Freezing the current image on the instrument screen

The secondary function of the FREEZE key (❄️) is to allow adjustment or manipulation of the frozen screen image. This is useful when calibrating for the inspection being performed. The direct-function keys that are functional while FREEZE is enabled are GAIN (**dB**), ANGLE (◁θ), and FREEZE (❄️):

- Pressing the GAIN key (**dB**) after FREEZE is enabled will alter the screen image to estimate the effect of a reduction or addition of gain on the instrument after FREEZE is disabled. Gain may be altered vertically, horizontally, or combined vertically and horizontally (see “GAIN” on page 82 for more details on changing the gain).
- Pressing the ANGLE key (◁θ) after FREEZE is enabled will alter the screen image to estimate the effect of changing the angle setting on the instrument signal after FREEZE is disabled. (see “ANGLE” on page 82 for more details on changing the angle).
- Pressing the REF SAVE key (REF ) after FREEZE is enabled will save the screen image and instrument settings to memory (see “REF SAVE” on page 82 for more details on REF SAVE). While FREEZE is active, the SET REF (set reference) functionality is disabled. If the REF SAVE key (REF ) is pressed and held for approximately 3 seconds, the instrument sounds a “beep,” which indicates that the image and settings are successfully saved.

To exit the FREEZE mode, press the FREEZE key (❄️).



GAIN (**dB**)



Used to adjust the instrument's gain settings. Pressing this key provides direct access to the instrument's gain settings while any instrument settings are displayed in the instrument settings menu (see Figure 2-5 on page 59). Pressing the GAIN key (**dB**) will display the instrument gain settings in the quick-access bar shown in Figure 2-5 on page 59. Multiple presses of the GAIN key (**dB**) will toggle between the combined horizontal and vertical gain settings, the horizontal gain settings only, or the vertical gain settings only. The knob is the primary method of changing this setting. For more information on gain, see "GAIN" on page 89.

ANGLE ()

Used to adjust the instrument's angle settings. Pressing this key provides direct access to the instrument's angle settings while any instrument settings are displayed in the instrument's settings menu (see Figure 2-5 on page 59). Pressing the ANGLE key () will display the instrument's angle settings in the quick-access bar shown in Figure 2-5 on page 59. The knob is the primary method of changing this setting. For more information on angle, see "ANGLE (rotation)" on page 88.

REF SAVE ()

The primary function of the REF SAVE direct-function key () is to save instrument's settings and screen images to the instrument memory. When the REF SAVE key () is pressed once (and released), the currently displayed image and settings are saved. Saved settings can later be recalled for reoccurring inspections. Saved screen images can be used in reports. Saved images can also be displayed on-screen to aid inspections (for more details, see "MEM" on page 83).

The secondary function of the REF SAVE direct-function key () is to set the current image as the reference image. If the REF SAVE key () is pressed and held (for approximately 3 seconds), the current instrument image is set as the reference memory display, as outlined in "SET REF (set reference image)" on page 100. After the image has been successfully saved in the reference memory, the instrument will sound a "beep."

To turn off any reference signal displayed in the background, simply press and hold the REF SAVE direct-function key () until the signal disappears.

4.2.4 Menu Keys

The menu keys located at the bottom of the instrument are used to select operation menus. Each of the menu keys provides access to two or more submenus. Repeated pressing of a menu key will toggle between the submenus. Pressing one of the function keys (A, B, C, D, or E) next to an operation menu item enables modification of the item, or access to additional menus or submenus. For more information, see “Menus” on page 88.

The following menu keys are available:

MAIN FILTER ()

Provides access to the main menu, which controls functions such as frequency, gain, angle, and filters.

DISP ()

Provides access to the display menu, which controls functions such as display mode, position, trace, and grid.

ALARM ()

Provides access to the alarm menu, which controls functions such as alarm type, dwell time, horn volume, and alarm position.

MEM ()

Provides access to the memory menu, which controls functions such as previewing stored memory files, recalling and editing stored files, capture mode, capture time, and user information.



ADV SETUP ()

Provides access to the **ALL SETTINGS** setup menu which controls instrument setup functions such as frequency mode, colors, password, unlock options, and reset. This menu displays all instrument settings at one time.

4.2.5 Knob

The knob (SmartKnob) is located in the upper left-hand side of the instrument. Its primary purpose is to adjust the selected instrument parameters. When the display box of the parameter being adjusted is highlighted, rotating the knob clockwise increases the value and rotating it counter-clockwise decreases the value. In some cases, the knob may also be used to respond to various prompts from the instrument.

4.2.6 Hidden Function — Screen Capture

On the NORTEC 600 instrument, you can send a screen-capture image file to the removable (external) microSD card by holding the MAIN FILTER menu key (), and then pressing and holding the REF SAVE key () until you hear a beep, after which you release the keys. Alternatively, you can use the NORTEC PC software to capture a screen image (see “Capturing a Screen Image Using NORTEC PC” on page 306).

4.2.7 Knobless Entry

Knobless entry is an additional useful function in the NORTEC 600 main menu that lets you change instrument’s settings (such as frequency, angle, and gain) in situations when rotating the knob may be difficult.

When this feature is enabled, two additional key presses (**UP** and **DOWN**) are available to change instrument settings (see Figure 4-7 on page 84).

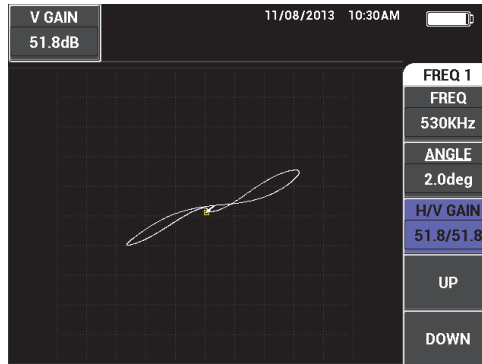



Figure 4-7 The UP and DOWN function in knobless entry

NOTE

- Only the gain, angle, and frequency are controlled by knobless entry.
- The following steps assume that the MAIN FILTER menu key () has been pressed.

To use knobless entry

1. Enable the knobless function in the **SYSTEM SETUP** screen (see “Enabling Knobless Entry for Harsh Environments” on page 74).
2. Press the A (**FREQ**, or frequency), B (**ANGLE**), or C (**GAIN**) function key.

NOTE

Consecutive presses of the C (**GAIN**) function key allow you to toggle through the various gain control options in the following order: **H/V GAIN** (combined horizontal and vertical gain), **H-GAIN** (horizontal gain), followed by **V-GAIN** (vertical gain). Subsequent presses of the C key will continue the toggling cycle.

3. Press the D (**UP**) function key to increase the setting.
OR
Press the E (**DOWN**) function key to decrease the setting.

4.2.8 Ambidextrous Controls

It is possible to change the location of control functions on the instrument screen, to adapt to both left-handed and right-handed operation.

To enable ambidextrous controls

1. Press the ADV SETUP menu key () twice, and then press the B key to access the **SYSTEM SETUP** screen (see Figure 4-8 on page 86).

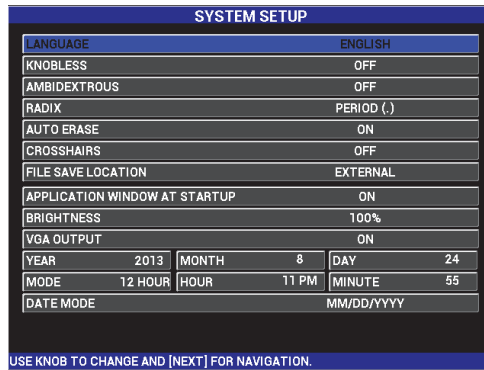

Figure 4-8 The SYSTEM SETUP screen

2. Repeatedly press the FULL NEXT key (→) until **AMBIDEXTROUS** is selected.
3. Rotate the knob to select **ON**, and then press the MAIN FILTER menu key (⌘) to display the controls on the right side of the instrument (see Figure 4-9 on page 86).

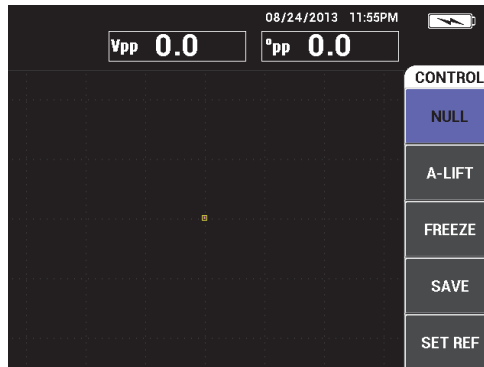

Figure 4-9 The controls displayed on the right side of the instrument

4.2.9 FULL NEXT key

The FULL NEXT key (→) has two main functions:

- 1. The primary function is to expand the viewing area of the instrument screen.
- 2. The secondary function is to navigate the menus.

If the FULL NEXT key (➡) is pressed while any inspection screen is active, the display is maximized, and any settings such as frequency, gain, angle, etc., will disappear. This permits full use of the NORTEC 600 display for inspections (see Figure 4-10 on page 87). The instrument's settings can be displayed again by pressing the FULL NEXT key (➡), or any other function or menu key.

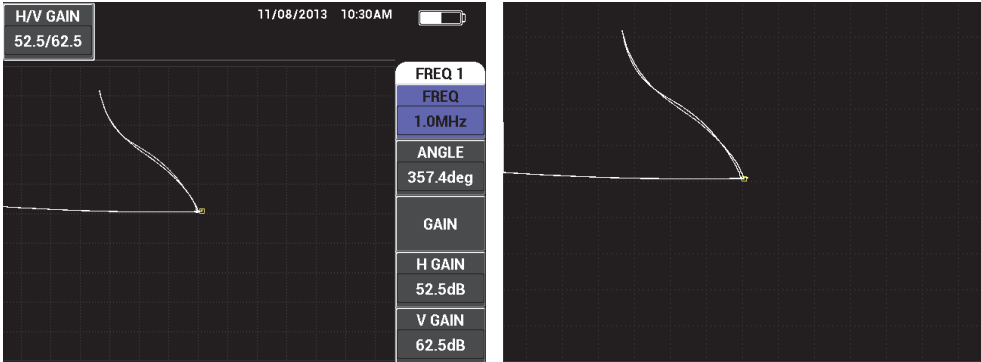
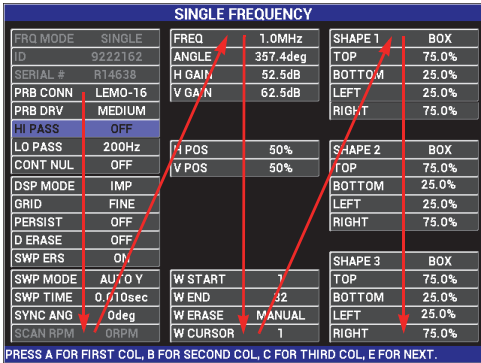

Figure 4-10 The settings display (left) and maximized display (right)

If a menu screen is active, the FULL NEXT key's secondary function can be used to navigate the menu structure (see Figure 4-11 on page 87).



The arrows represent menu navigation: press the FULL NEXT key repeatedly to step through the menu as indicated.

Figure 4-11 Using the FULL NEXT key to navigate a menu

4.3 Menus

The NORTEC 600 menus described in this section are opened by pressing the corresponding menu keys, which are described in “Menu Keys” on page 83.



4.3.1 Frequency (FREQ 1) Menu — MAIN FILTER Key

FREQ (frequency)

The **FREQ** setting determines the frequency of the drive signal of the eddy current probe. This is adjustable from 10 Hz (0.01 kHz) to 12 MHz.

To adjust the frequency setting, press the MAIN FILTER menu key (), followed by the A key. With **FREQ** highlighted, rotate the knob until the desired frequency is displayed.

TIP

To speed up the frequency selection process, press the Enter key () once while the **FREQ** function is highlighted to enable the coarse knob function. **FREQ** will be underlined when this function is enabled. To turn off the coarse-knob function, press  one more time.

ANGLE (rotation)

The phase angle (or rotation) of the eddy current signal is set using the ANGLE key (). By default, the angle is set in 1 degree increments, from 0 to 359 degrees.

To adjust the angle setting, press the MAIN FILTER menu key (), followed by the B key. With **ANGLE** highlighted, rotate the knob until the desired angle is displayed.

TIP

To enable the fine-knob function, press the Enter key (✓) when **ANGLE** is highlighted. The fine-knob function can be used to adjust the angle more precisely. **ANGLE** will be underlined when this function is enabled. The angle can then be changed in 0.1 degree increments. To turn off the fine-knob function, press ✓ one more time.

GAIN

Gain is adjustable from 0.0 dB to 100.0 dB. The displayed gain setting is adjusted in 0.1 dB steps. At full gain (100 dB), with the instrument's probe drive set to **MEDIUM**, instrument sensitivity is 10 V/Ω, as measured at the rear panel horizontal and vertical outputs. In other words, ten screen divisions represents an impedance change of one ohm on the display.

Gain can be adjusted independently in the horizontal or vertical direction, or in both directions simultaneously. The primary method of adjusting gain is by turning the knob. However, gain may also be adjusted by using the knobless function (for more details, see "Knobless Entry" on page 84).

To adjust the horizontal and vertical gain simultaneously, press the MAIN FILTER menu key (✂), followed by the C key. The gain may then be adjusted with the knob. The selected value will be applied to both the horizontal and the vertical gain, and the difference between the horizontal and vertical gains will remain constant; they will increase or decrease at the same rate.

To adjust the horizontal gain only (without changing the vertical gain), press the MAIN FILTER menu key (✂), followed by the D key. The knob will then adjust only the horizontal gain. To adjust only the vertical gain, press the E key. The knob will then adjust only the vertical gain.

TIP

To speed up the gain selection process (while the combined horizontal and vertical gain, horizontal gain, or vertical gain function is highlighted), press ✓ once. This enables the coarse-knob function. **GAIN**, **H GAIN**, or **V GAIN** will be underlined

when this function is enabled. The gain can then be changed in 1.0 dB increments. To turn off the coarse-knob function, press ✓ one more time, which returns the gain adjustments to 0.1 dB increments.

4.3.2 Filter Menu — MAIN FILTER Key

Filters

High-pass filters may be set from 0 Hz (**OFF**) to 100 Hz in 1 Hz increments, and from 100 Hz to 1000 Hz in 5 Hz increments. To adjust the **HI PASS** filter settings, press the MAIN FILTER menu key (✂) two times, followed by the A key, and then rotate the knob to the desired value.

Low-pass filters may be set from 10 Hz to 100 Hz in 1 Hz increments, up to 500 Hz in 5 Hz increments, and up to 2000 Hz in 25 Hz increments, followed by wide band. To adjust the **LO PASS** filter settings, press the MAIN FILTER menu key (✂) two times, followed by the B key, and then rotate the knob to the desired value.

CONT NUL (continuous null)

CONT NUL allows a very low-frequency high-pass filter to be turned on, which is useful to keep the null point of the eddy current probe at the specified point, if required. When turned on, this function adds a 0.2 Hz, 0.5 Hz, or 1 Hz high-pass filter. By default, this feature is set to **OFF**.

To turn on continuous null, press the MAIN FILTER menu key (✂) two times, followed by the C key, and then rotate the knob to the desired value.

LINK

The **LINK** function is used to automatically adjust the values of the high-pass and low-pass filters in accordance with the scanner speed (**SCAN RPM**). It is only used for the rotating-scanner mode.

To turn on **LINK**, press the MAIN FILTER menu key (✂) two times, followed by the D key, and then rotate the knob to **ON**.

SCAN RPM (NORTEC 600S and NORTEC 600D models only)

The **SCAN RPM** function controls the scanner rotational speed (revolutions per minute) when an optional rotating scanner is connected to the NORTEC 600S (N600S) or NORTEC 600D (N600D) instrument models.

To adjust the **SCAN RPM** setting, press the MAIN FILTER menu key () two times, followed by the E key, and then rotate the knob to the desired value.

4.3.3 Special Menu — MAIN FILTER Key

PRB DRV (probe drive)

The NORTEC 600 instrument has three levels of probe drive that can be selected: **LOW**, **MEDIUM**, and **HIGH**. The approximate peak-to-peak voltages are 2 V, 6 V, and 12 V, respectively.

MEDIUM probe drive (the default setting) is normally sufficient for most eddy current testing. However, **HIGH** probe drive is desirable in the following cases:

- a) If gain is insufficient at the lower probe-drive settings.
- b) During testing of lower conductivity materials.
- c) For finding smaller flaws in the test material.
- d) For deeper penetration into the test material.

To adjust the probe-drive level, press the MAIN FILTER menu key () three times, followed by the A key. With **PRB DRV** highlighted, rotate the knob to the desired level.

PRB CONN (probe connection)

The NORTEC 600 instrument supports two types of probe connections: BNC and 16-pin LEMO. The probe input by default is set to 16-pin LEMO. If the BNC connector is used, the connection input needs to be changed manually.

To adjust the probe-connection input, press the MAIN FILTER menu key () three times, followed by the B key. With **PRB CONN** highlighted, rotate the knob to select the desired connector: **LEMO-16** or **BNC**.

NOTE

If the BNC connector is used, it is automatically balanced (no internal or external load is required).

FILT TYPE

The **FILT TYPE** function lets you choose between two types of filters: **FIG 6** and **FIG 8**. This option is only available for rotating scanner mode.

To access **FILT TYPE**, press the MAIN FILTER menu key () three times, followed by the C key, and then use the knob to select **FIG 6** or **FIG 8**.

For more details on **FILT TYPE**, see “Filter Type — Figure 6 or Figure 8 Signals” on page 140.



SIG TYPE

SIG TYPE (signal type—absolute or differential) is displayed only when using an adapter compatible with one of the six heat exchanger tubing applications (see “Heat Exchanger Tubing Applications” on page 234).

Slide Rule

The NORTEC 600 instrument includes a useful slide-rule tool for determining the standard depth of penetration for a given material at a specified frequency. The user can select a material from the list or enter a specific conductivity value.

The slide-rule tool can also determine the necessary frequency for a given depth of penetration. The separation angle is assumed to be 118 degrees for this calculation.

To access the slide-rule menu, press the MAIN FILTER menu key () three times, followed by the E key. When the **EDDY CURRENT SLIDE RULE** menu is displayed, use the FULL NEXT key () to navigate the menu functions. Additional navigation instructions and information is displayed in the help text at the bottom of the screen (see Figure 4-12 on page 93).

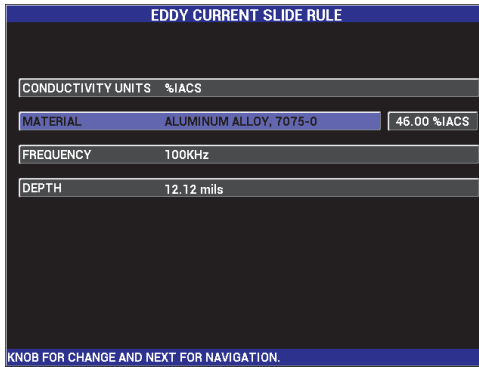



Figure 4-12 The EDDY CURRENT SLIDE RULE menu

4.3.4 Display Menu — DISP Key

The display menu contains submenus to control various functions such as horizontal and vertical position, display erase, trace, grid, and zoom.

DSP MODE (display mode)

Six display modes are available on the NORTEC 600 instrument: **IMP** (impedance), **SWP+IMP** (sweep plus impedance), **SWEEP**, **WATERFALL**, **DUAL IMP** (dual impedance), and **ALL IN ONE**.

To adjust the display mode, press the DISP menu key () , followed by the A key. With **DSP MODE** highlighted, rotate the knob until the desired display mode is displayed.

IMP

Impedance mode is the most common display mode. It incorporates a **10 × 10** grid configuration on the screen. The eddy current signal is shown moving horizontally and vertically.

SWEEP

Commonly used with rotating scanners. The eddy current signal is shown moving horizontally at a fixed rate across the screen.

SWP+IMP (NORTEC 600S and NORTEC 600D models only)

Typically used while setting up an inspection using a rotating scanner. Impedance (**IMP**) and **SWEEP** screens are displayed together on a “split screen.”

WATERFALL (NORTEC 600S and NORTEC 600D models only)

Used with rotating scanners. Multiple sweep traces are displayed across the screen during hole inspection.

DUAL IMP (NORTEC 600D model only)

Used during setup of dual frequency inspections (for more details, see “Dual Frequency Menus” on page 115 and “Display Menu in Dual Frequency – DISP Key” on page 122).

ALL-IN-1 (NORTEC 600D model only)

Used during setup of dual frequency inspections (for more details, see “Dual Frequency Menus” on page 115 and “Display Menu in Dual Frequency – DISP Key” on page 122).

CHANNEL

This mode is for the NORTEC 600D model, and is only functional during dual frequency inspection. For more details, see “Display Menu in Dual Frequency – DISP Key” on page 122.

POSITION

Used to select the NORTEC 600 instrument’s null position. By default, the null position is set at the center of the instrument screen. There are five preset null positions, as well as a modifiable position named **CUSTOM**.

To adjust the null position, press the DISP menu key () , followed by the C key. With **POSITION** highlighted, rotate the knob until the desired position is displayed.

CENTER

Places the null position at the center of the screen.

BOT RGHT

Places the null position near the bottom right of the screen, at 80 % horizontal and 20 % vertical.

BOT CNTR

Places the null position near the bottom center, at 50 % horizontal and 20 % vertical.

TOP CNTR

Places the null position near the top center, at 50 % horizontal and 80 % vertical.

TOP LEFT

Places the null position near the top left, at 20 % horizontal and 80 % vertical.

CUSTOM

Places the null position at a user-determined point, between 0 % and 100 % horizontal and between 0 % and 100 % vertical. Press **H POS** (horizontal position) or **V POS** (vertical position) to create a custom null position.

NOTE

If the horizontal or vertical position is modified after a preset null position is chosen, the **POSITION** selection reverts to **CUSTOM**.

H POS

Changes the null position in the horizontal axis. To change the horizontal position, press the DISP menu key () , followed by the D key, and then rotate the knob to the desired setting.

V POS

Changes the null position in the vertical axis. To change the vertical position, press the DISP menu key () , followed by the E key, and then rotate the knob to the desired setting.

D ERASE (display erase)

Erases the eddy current display at user-determined time intervals. The available range for **D ERASE** is 0.1 s to 60 s, in 0.1 s intervals.

To activate display erase, press the DISP menu key () , followed by the B key. With **D ERASE** highlighted, rotate the knob to adjust to the desired value.

NOTE

The display erase function is not available if variable persistence (**PERSIST**) is activated.

PERSIST (variable persistence)

Enables automatic screen erase. You can set the display on an impedance plane (not sweep) so that the signal traces on the screen will be erased after a

predetermined amount of time. This time may be set from 0.1 s to 10 s, in 0.1 s increments. By default this feature is set to **OFF**.

PERSIST erases all information at a particular point after the selected amount of time has expired, even if more information is displayed there at a later time. As a result, the displayed signal might appear broken where the eddy current signals intersect the signals being erased. However, the resulting display is very useful for repetitive testing, because it is no longer necessary to manually erase the screen.

To activate variable persistence, press the DISP menu key () , followed by the C key. With **PERSIST** highlighted, rotate the knob to adjust to the desired value.

NOTE

PERSIST is not available if display erase (**D ERASE**) or sweep mode (**SWEEP**) is activated. In some applications, **PERSIST** may slow down the instrument's data acquisition rate, resulting in decreased instrument performance. If this is the case, it is recommended to use display erase instead.

CURSOR

Adjusts the display of the eddy current signal trace on the NORTEC 600 screen by changing the shape of the signal focal spot. Two settings are available: **DOT** and **BOX**.

To adjust **CURSOR**, press the DISP menu key () , followed by the D key. With **CURSOR** highlighted, rotate the knob to adjust to the desired value.

GRID

Five screen grid types are available: **OFF**, **10 × 10**, **FINE**, **COARSE**, and **WEB**. By default, the NORTEC 600 instrument uses a 10 × 10 grid.

To adjust the grid setting, press the DISP menu key () , followed by the E key. With **GRID** highlighted, rotate the knob to adjust to the desired value.

OFF

The instrument does not display a grid pattern.

10 × 10

A 10 by 10 grid pattern is displayed, with some unusable areas on the left and right sides of the screen.

FINE

A grid with 13 horizontal (centered) and 10 vertical divisions is displayed. The grid divisions furthest to the left and right are half the normal width.

COARSE

A grid with 6.5 horizontal (centered) and 5 vertical (centered) divisions is displayed. The grid divisions at the top and bottom are half the normal width, and grid divisions furthest to the left and right are one-quarter the normal width.

WEB

Provides a polar grid.

ZOOM

Adjusts the viewable portion of the NORTEC 600 screen. The null-point area of the instrument screen is magnified by applying a horizontal and vertical digital gain of 10.

In **ZOOM** mode, all display functions are disabled, with the exception of **ZOOM OFF** or **ON**.

To enable **ZOOM**, press the DISP menu key () twice, followed by the E key. With **ZOOM** highlighted, rotate the knob to turn Zoom on or off.

4.3.5 Alarm Menu — ALARM Key

Four types of alarms are available: box, polar, sector, and sweep. The alarm menu controls the following functions:

1. Enable (**ON**) or disable (**OFF**) the alarms.
2. Determine the polarity of the alarm (positive or negative).
3. Enable or disable **DWELL** time (0 s to 10 s), which is the length of time the alarm condition continues after the alarm threshold was first detected.

To access the alarm menu, press the ALARM menu key () . For additional information, see “Alarm Menus” on page 298.

4.3.6 Memory Menu — MEM Key

The memory menu contains functions for storage of programs and screen images. Various editing functions are provided in this menu for previewing stored (saved) data, recalling stored data, editing file names, adding notes, setting a reference image, and erasing stored data.

The NORTEC 600 is capable of storing and retrieving complete instrument setups. By default, the data is saved with the date, time, and instrument-generated file name. If a PowerLink probe remains connected when the data is stored, the probe part number and description are also recorded. After the data is stored, the file name can be changed by using up to 29 alphanumeric characters, and notes can be added to the file. Changes to the file name and notes are made using the front panel of the instrument, or alternatively, by using the NORTEC PC software (included with each instrument).

NOTE

Whenever a program (stored data file) is recalled, the currently active instrument settings are overwritten and cannot be recovered, unless these settings were previously stored in another program location.

The following memory storage, or MEM () functions are available:

PREVIEW

Used to view instrument screen images that were captured at the moment the data was saved.

To preview a stored data file, press the MEM menu key () , rotate the knob until the desired data file is highlighted, and then press the A key. The instrument screen image that was stored at the time the data file was saved will appear on the instrument screen. The following steps can be taken:

- Exit (return to the previous menu) by pressing the A key.
- Recall the stored data file by pressing the B key.
- Set the data file as a reference image by pressing the D key.
- Show or hide readings by pressing the C key (see Figure 4-13 on page 99 and Figure 4-14 on page 99).

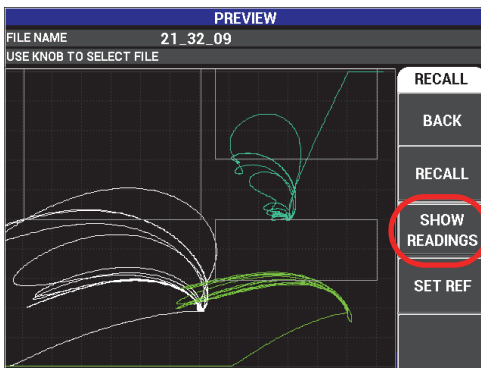

Figure 4-13 The SHOW READINGS function

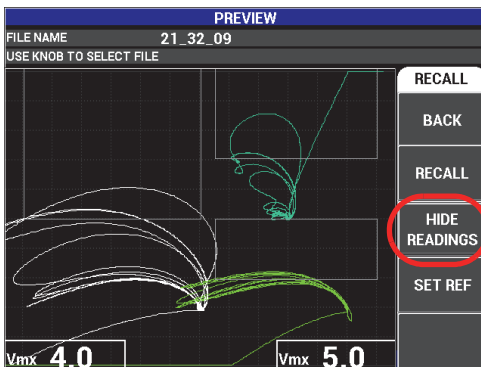



Figure 4-14 The HIDE READINGS function

RECALL

Resets the instrument and loads the instrument settings associated with the data file that is recalled.

To recall a stored data file, press the MEM menu key () (SD), rotate the knob until the desired data file is highlighted, and then press the B key. The instrument recalls the data file with the instrument settings that were stored when the data file was saved.

EDIT



Enables editing of the file name and adding user **FILE NOTES** (text) to the stored data.

To edit text (**FILE NAME** or **FILE NOTE**) of a stored data file, press the MEM menu key () (**SD**), rotate the knob until the desired data file is highlighted, and then press the C key; a text editor screen will appear on the instrument display.

For more information, see “Memory Text Editor” on page 102.

SET REF (set reference image)

Allows the screen image that was stored with the data file to be displayed on the present instrument screen (in a contrasting color) while performing inspections. The displayed image cannot be erased until the **SET REF** function is turned off.

To display a reference image, press the MEM menu key () (**SD**), rotate the knob until the desired data file is highlighted, and then press the D key. Alternatively, a reference image may be created using the current screen image by pressing and holding the REF SAVE direct-function key () until the instrument sounds a “beep.”

To turn off a reference image, press the MEM menu key () (**SD**), and then press the D key.

NOTE

An error message will appear when turning on the **SET REF** (set reference) function if the selected **DSP MODE** (display mode) is not compatible with the currently active **DSP MODE**.

For example, an error message occurs when the **SET REF** image being activated contains a stored image with a **DSP MODE** setting of **SWP+IMP**, if the current mode is **IMP**.

ERASE

Erases the selected program number (stored data file).

To erase a stored data file, press the MEM menu key () (**SD**), rotate the knob until the desired data file is highlighted, and then press the E key.

STORE

Used to overwrite an existing file with the current settings and data.

To overwrite a file, select it with the knob, then press the MEM menu key () until the **GENERAL** page is displayed, and then press the A key (see Figure 4-15 on page 101).

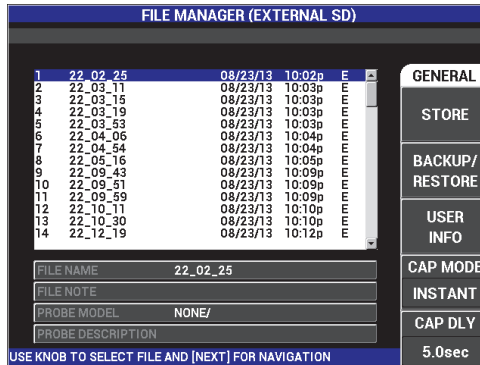

Figure 4-15 The STORE function

BACKUP / RESTORE

Used to create a backup copy of the instrument data, which is then saved on the external microSD card. This image can then be transferred to a computer or to another NORTEC 600 instrument.

If the external microSD card contains data, this function acts as a **RESTORE**: the SD card's data contents are copied to replace the instrument's internal memory.

IMPORTANT

The **RESTORE** function erases the instrument's internal memory and replaces it with the data contents of the external SD card. **BACKUP / RESTORE** saves files on the internal memory's microSD card.

To back up the instrument's data or restore the instrument's internal memory, press the MEM menu key () twice, and then press the B key followed by the A key or B key to either backup or restore.

USER INFO

Allows you to enter information on the user, job, company, work order, instrument serial number, etc. The information in **USER INFO** can easily be transferred into the NORTEC PC software and used as a header for reports.

CAPTURE MODE

In all modes except conductivity, **CAPTURE MODE** defines the action performed by the instrument when the REF SAVE key () is pressed. There are two capture modes:

- **INSTANT**: The data on the screen is instantly saved when the key to select this option is pressed. This is the default mode, which is most commonly used.
- **DELAYED**: It is possible to specify a delay (**CAPTURE DELAY**) for data saving after the REF SAVE key () is pressed. This feature can help you correctly place the probe before data is saved; for example, during scanning operations that require two hands.

CAPTURE DELAY

Specifies the data-saving delay when **CAPTURE MODE** is set to **DELAYED**.

4.3.7 Memory Text Editor

The memory text editor appears on the instrument screen when editing the file name or file text fields. This section provides instructions on how to use this editor to change the file names and file notes.

NOTE

The following procedure assumes that the MEM menu key () has already been pressed, and that the **FILE MANAGER** menu is displayed (see Figure 4-16 on page 103).

To use the memory text editor

1. Rotate the knob to highlight the file to be edited.

2. Press the FULL NEXT key () to navigate to the desired field to be edited: **FILE NAME** and/or **FILE NOTE**.
3. Press the C key.
The memory text editor is activated on the instrument display (see Figure 4-16 on page 103).

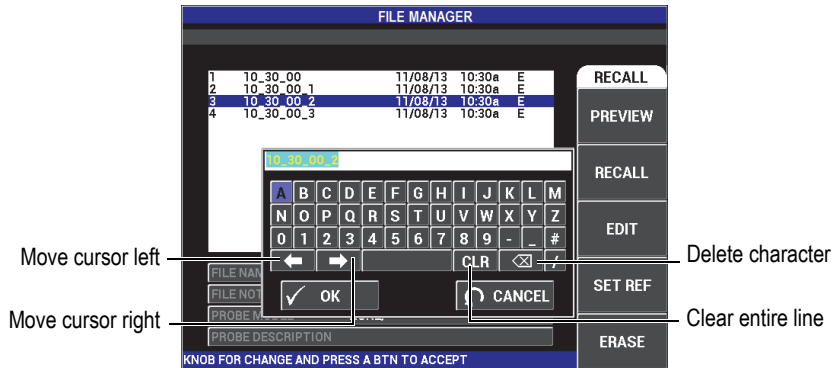





Figure 4-16 The FILE MANAGER menu's memory text editor and special buttons







4. Use the knob to select characters, and press the FULL NEXT key () to accept the characters.
5. After the **FILE NAME** or **FILE NOTE** has been edited, press  to save the changes, or press  to exit without saving.

NOTE







By default, the text editor highlights the entire original default file name. If a key is subsequently pressed, the default file name or file note will be deleted. This is also the case for a previously edited **FILE NAME** or **FILE NOTE**. However, it is possible to avoid deletion (retain the information) by using the text editor navigations keys or buttons, as outlined below.

The navigation keys or special buttons in the text editor allow you to modify characters that have been mistakenly chosen, or modify previously entered information, without the need to retype the entire field (see Figure 4-16 on page 103, which identifies the special buttons and characters).

To insert a character with the navigation keys

1. Rotate the knob until the forward () or backward () arrow is highlighted.
2. Repeatedly press the FULL NEXT key () until the cursor is in the correct location.
3. Use the knob to select characters, and press the FULL NEXT key () to accept characters.
4. After all the desired characters have been selected, press  to accept, or press  (return) to cancel.

To delete a character with the navigation keys

1. Rotate the knob until the forward () or backward () arrow is highlighted.
2. Repeatedly press the FULL NEXT key () until the cursor is in the correct location (after the character to be deleted).
3. Use the special deletion button () to delete the character(s).
4. If required, use the knob and the FULL NEXT key () to add new characters.
5. After completing the deletion(s), press  to accept, or press  (return) to cancel.

To clear (delete) the entire field with the navigation keys

- ◆ To delete the entire field (line) and start over at any time during text editing, rotate the knob and choose the clear button (**CLR**), and then press the FULL NEXT key ().

4.3.8 Advanced Setup Menu — ADV SETUP Menu Key

The advanced setup menu provides access to the following functions:



APPL SELECT (application select), **ALL SETTINGS**, **FRQ MODE** (frequency mode), **COLOR**, **PASSWORD**, **SYSTEM SETUP**, **UNLOCK OPTIONS**, **ABOUT**, and **RESET**. For details about **SYSTEM SETUP**, see “Setting the User Interface Language and the Decimal Symbol” on page 69.

APPL SELECT (application select)

Provides access to the application selection menu, which opens in a new window (see Figure 4-17 on page 106).

IMPORTANT

To save setup time and effort, it is strongly recommended to navigate through the application selection menu, as it may contain a configuration that can help you quickly set up the instrument for your requirements. For further details, see also “Common NORTEC 600 Applications” on page 126.

To select an application, press the ADV SETUP menu key (), followed by the A key. With **APPL SELECT** highlighted, rotate the knob to select the desired application. Or, to exit the menu, press the Return key ().

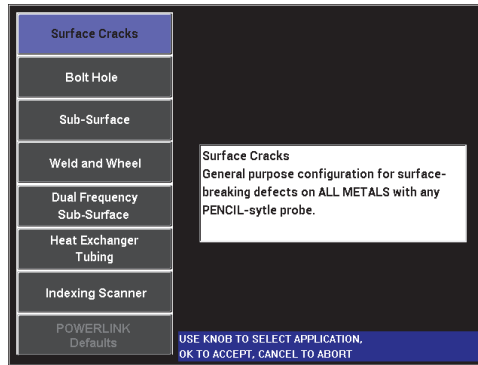

Figure 4-17 The application selection menu

The eight available applications allow you to quickly set up the instrument for commonly used eddy current inspections.

NOTE

The NORTEC 600 applications are designed for quick setup of the instrument. However, always follow published maintenance procedures when inspecting.

ALL SETTINGS

The **ALL SETTINGS** menu gives you access to all instrument menus. They are contained in two separate screens (menus) to keep the text easy to read and to navigate (see Figure 4-18 on page 107).

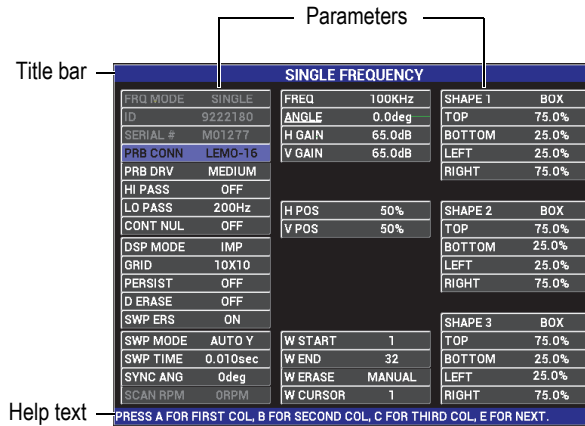



Figure 4-18 The ALL SETTINGS menu (first of two screens)

To select **ALL SETTINGS**, press the ADV SETUP menu key () followed by the B key. To navigate the menu or to go to the next screen, follow the instructions in the help text at the bottom of the screen. To select a setting to adjust, repeatedly press the FULL NEXT key until the desired setting is highlighted, and then rotate the knob until the desired value is shown.

NOTE

The NORTEC 600 instrument does not use an enter key to save the selection made on any of its menus. Instead, the selected (displayed) value is automatically saved.

FRQ MODE (frequency mode)

This option, which supplements single frequency operation with dual-frequency capability, is only available for the N600D model. Parameters that are adjustable for the second frequency are frequency, gain, and rotation (angle).

The NORTEC 600D instrument includes the following features:

- Two independent frequencies: frequency 1 (F1) and frequency 2 (F2).
- Two independent vertical and horizontal gain settings for F1 and F2.
- Two independent angle settings for F1 and F2.

- The ability to add, subtract, and mix the two frequencies (F1 and F2) on the display.
- A “mix” **GAIN** range from –6 dB to 18 dB with normal incremental values.
- Shared filter settings for F1 and F2.

Dual-frequency mode is controlled via the advanced setup (ADV SETUP) menu key (). By default, the mode is set to single frequency.

To enable dual-frequency mode

- (1) Press the ADV SETUP menu key ().
- (2) Press the C key, and then rotate the knob to select the desired value: **DUAL** for dual frequency or **SINGLE** for single frequency.

Dual-frequency controls

Dual-frequency controls are similar to those in single frequency mode, except that there are additional frequency, angle, and gain menus for frequency 2 (F2). Figure 4-19 on page 108 and Figure 4-20 on page 109 contain examples of the MAIN FILTER () menus with dual frequency enabled. For more details on how to use this mode, see “Dual Frequency Menus” on page 115.

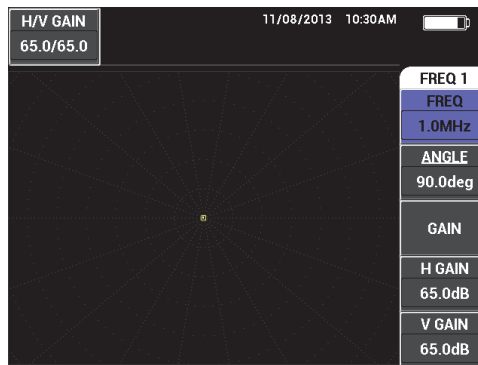

Figure 4-19 The FREQ 1 menu

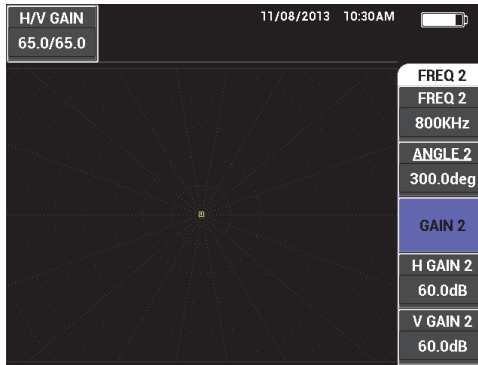



Figure 4-20 The FREQ 2 menu

Dual-frequency mix controls

The **MIX** menu allows the NORTEC 600D instrument to mix frequency 1 and frequency 2, and display the results on the instrument screen.

To access the **MIX** menu, press the MAIN FILTER menu key () . For more details, see “MIX Menu in Dual Frequency – MAIN FILTER Key” on page 119.

COLOR

The NORTEC 600 instrument includes user-selectable color schemes.

The color palate on the screen can be changed as follows:

- (1) Press the ADV SETUP menu key () .
- (2) Press the E key, and then rotate the knob to select the color palette.

PASSWORD

The stored data and instrument reset capabilities can be protected with a password to prevent accidental deletion of data (see Figure 4-21 on page 110).

IMPORTANT

The default factory password is **OLYN600**.

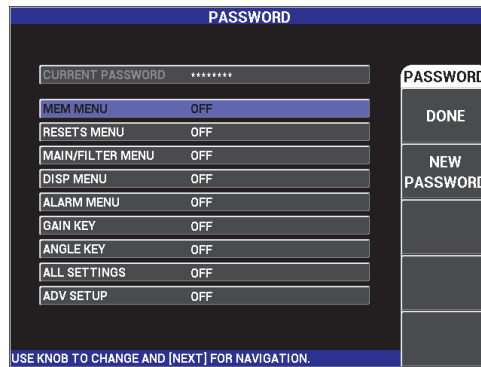



Figure 4-21 The PASSWORD menu

The **PASSWORD** function is accessed as follows:

- (1) Press the ADV SETUP menu key () twice.
- (2) Press the A key.

The password is set as follows:

- (1) Press the FULL/NEXT key to navigate to the item to protect with a password: **FILE MENU** or **RESETS MENU**.
- (2) Press the FULL/NEXT key to navigate to the text editor.
- (3) Rotate the knob to select the characters of the password. When finished, press the A key to **ACCEPT**.
- (4) Press the FULL/NEXT key to navigate to another item to protect with a password, and repeat steps 1 through 3 above, or press  to exit.

SYSTEM SETUP

Used to configure the NORTEC 600 instrument's language, date, time, display brightness, and other settings (see Figure 4-22 on page 111; for more details, see "Initial Setup" on page 69). Here you can also select the application screen that appears when the instrument starts up (see "Selecting the Startup Screen" on page 73).

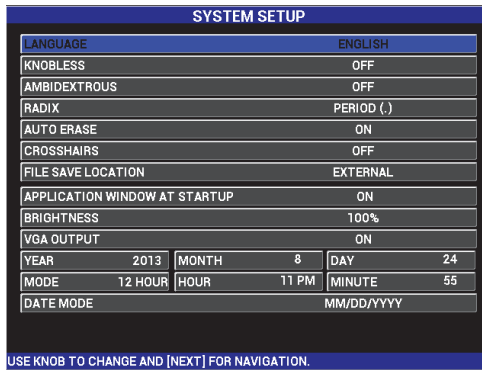



Figure 4-22 The SYSTEM SETUP screen

UNLOCK OPTIONS

Provides access to purchased instrument upgrades that can be enabled by the operator. These include model upgrades: N600 to N600C model, N600C to N600S model, N600S to N600D model, etc. A full list of possible upgrades and part numbers is listed in Table 11 on page 348.

To unlock options, press the ADV SETUP menu key () twice, followed by the C key, and then enter the option code for the upgrade.

For more information on this feature, contact your local Evident representative. Contact information for your region can be found by visiting the Evident website at <https://www.olympus-ims.com/en/contact-us/>.

ABOUT

This feature displays the instrument configuration and other important information. Occasionally, when required by service technicians or product representatives, this feature will help factory personnel identify your instrument and/or troubleshoot problems. It is provided to help meet current user requirements and also assists with any future upgrades.

To access the **ABOUT** menu, press the ADV SETUP menu key () twice, followed by the D key.

The **ABOUT** menu provides access to the following sections:
BATT & TEMP (battery and instrument temperature, battery level, battery capacity, battery design capacity, and battery status), **LEGAL INFO** (legal

information), **UPGRADE** (instrument software upgrade), and **TESTS** (see Figure 4-23 on page 112).

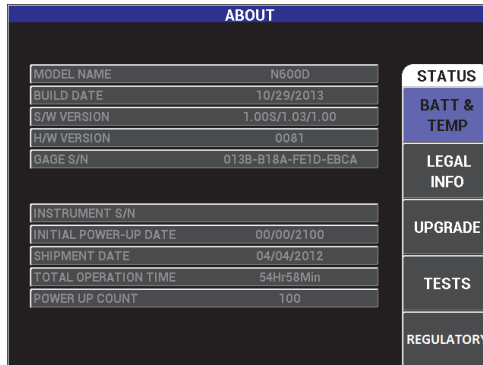



Figure 4-23 The ABOUT menu



BATT & TEMP

Provides the battery and instrument internal temperature, and information on model name, date of manufacture, software and hardware versions, instrument serial number, etc.

To access the **BATT & TEMP** menu, press the ADV SETUP menu key () , followed by the D key, and then the A key. To exit, press the Return key ().

LEGAL INFO

Displays legal or patent rights protection information for the NORTEC 600 eddy current instrument.

To access the **LEGAL INFO** menu, press the ADV SETUP menu key () , followed by the B key. To navigate the menu, follow the instructions in the help text at the bottom of the screen. To exit, press the Return key ().

REG

Displays regulatory information for the NORTEC 600 eddy current instrument (see Figure 4-24 on page 113).

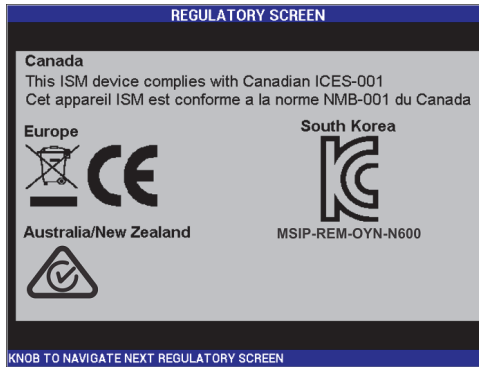



Figure 4-24 The REGULATORY SCREEN



UPGRADE

Provides information on software and hardware upgrades.

To access the **UPGRADE** menu, press the ADV SETUP menu key () followed by the C key, and then follow the on-screen instructions. To exit, press the Return key (.

TESTS

Provides operator-accessible tests to help troubleshoot the instrument. Tests include **VIDEO TEST**, **KEYPAD TEST**, **SD CARD TEST**, and **LED TEST**.

To access the **TESTS** menu, press the ADV SETUP menu key () followed by the D key. Rotate the knob until the desired test is shown and then press the A key to begin the test. To exit the **TESTS** menu, press the Return key (.

- **VIDEO TEST**—Checks the instrument by displaying three equal-width color bands: red, green, and blue. The test fails if one or more of the equal-width bands is not present. To exit the video test, press the Return key (). Subsequently, the **TESTS** menu reappears on the instrument display.
- **KEYPAD TEST**—Checks if the instrument keypad is operating correctly and displays the last key that was pressed. The test continues until the

Return key () is pressed. Subsequently, the **TESTS** menu reappears on the instrument display.

- **SD CARD TEST**—Checks the internal SD card and external SD card (if present), and presents a **PASSED** or **FAILED** response. To exit the SD card test, press the Return key (). Subsequently, the **TESTS** menu reappears on the instrument display.

NOTE

If an external SD card is not present during the SD card test, **FAILED** will be displayed for this storage device.

- **LED TEST**—Checks if the instrument LEDs (light-emitting diodes) are operational. The LEDs are located above the EVIDENT logo on the instrument, and are marked with the numbers 1, 2, and 3. During the test, each individual LED should display a sequence of green, yellow/orange, and red colors before continuing to the next individual LED color sequence. If any of these colors are not present, the LED is not working correctly. To exit the LED test, press the Return key (). Subsequently, the **TESTS** menu reappears on the instrument display.

NOTE

The battery or charging indicator LED is not tested during the **LED TEST** and can instead be manually inspected. For more information on this LED, see “Charger/Adapter” on page 33.

RESET

Provides the ability to reset the instrument as follows:



- (1) To access the **RESET** menu, press the ADV SETUP menu key () followed by the E key, and then rotate the knob to select the desired type of instrument reset: parameters, storage, or master (see Figure 4-25 on page 115 and Table 3 on page 115).
- (2) To perform the reset, press the A key.
- (3) To exit, press the Return key (.



Figure 4-25 The RESET menu

Table 3 Reset types

Reset type	Description
Parameters reset	Clears only the instrument settings, and returns the instrument to its default settings.
Storage reset	Clears all stored programs and screen images.
Master reset	Clears the instrument settings, stored programs, and screen images, and returns the instrument to its default settings.

4.4 Dual Frequency Menus

Dual frequency mode provides added gain functionality, and is available on NORTEC 600D models only. When dual frequency is enabled, its menus can be opened by pressing the corresponding basic operation keys, as described in “Menu Keys” on page 83.



4.4.1 Frequency (FREQ 1) Menu — MAIN FILTER Key

FREQ 1 (frequency 1)

The **FREQ 1** setting determines the frequency 1 drive signal of the eddy current probe. This is adjustable from 10 Hz (0.01 kHz) to 12 MHz.

To adjust the frequency setting, press the MAIN FILTER menu key () followed by the A key. With **FREQ 1** highlighted, rotate the knob until the desired frequency is displayed.

TIP



To speed up the frequency selection process, press the Enter key () while the **FREQ** function is highlighted to enable the coarse-knob function. **FREQ 1** will be underlined when this function is enabled. To turn off the coarse-knob function, press  one more time.

ANGLE (rotation)

The phase angle (or rotation) of the eddy current signal is set using the ANGLE key (). By default, the angle is set in 1 degree increments, from 0 degrees to 359 degrees.

To adjust the angle setting, press the MAIN FILTER menu key () followed by the B key. Once the **ANGLE** function is highlighted, rotate the knob until the desired angle is displayed.

TIP

To be able to adjust the angle more precisely, press the Enter key () once while the **ANGLE** function is highlighted to enable the fine-knob function. **ANGLE** will be underlined when this function is enabled. The angle can then be changed in 0.1 degree increments. To turn off the fine-knob function, press  one more time.

GAIN



Gain is adjustable from 0.0 dB to 100.0 dB. The displayed gain setting is adjusted in 0.1 dB steps.

Gain can be adjusted independently in the horizontal or vertical direction, or in both directions simultaneously. The primary method of adjusting gain is by turning the knob. However, gain may also be adjusted by using the knobless function (see “Knobless Entry” on page 84 for more details).

To adjust the horizontal and vertical gain simultaneously, press the MAIN FILTER menu key (), followed by the C key. The gain may then be adjusted with the knob. The selected value will be applied to both the horizontal and the vertical gain, and the difference between the horizontal and vertical gains will remain constant; they will increase or decrease at the same rate.

To adjust the horizontal gain only (without changing the vertical gain), press the MAIN FILTER menu key (), followed by the D key. The knob will then adjust only the horizontal gain. To adjust only the vertical gain, press the E key. The knob will then adjust only the vertical gain.

TIP

To speed up the gain selection process (while the combined horizontal and vertical gain, horizontal gain, or vertical gain function is highlighted), press  once, which enables the coarse-knob function. **GAIN**, **H GAIN** or **V GAIN** will be underlined when this function is enabled. The gain can then be changed in 1.0 dB increments. To turn off the coarse-knob function, press  one more time, which returns to gain adjustments in 0.1 dB increments.

4.4.2 Frequency (FREQ 2) Menu — MAIN FILTER Key

FREQ 2 (frequency 2)

The **FREQ 2** setting determines the frequency 2 drive signal of the eddy current probe. This is adjustable from 10 Hz (0.01 kHz) to 12 MHz.

To adjust the frequency setting, press the MAIN FILTER menu key () twice, followed by the A key. With **FREQ 2** highlighted, rotate the knob until the desired frequency is displayed.

TIP

To speed up the frequency selection process, press the Enter key (✓) once while the **FREQ** function is highlighted to enable the coarse-knob function. **FREQ 2** will be underlined when this function is enabled. To turn off the coarse-knob function, press ✓ one more time.

ANGLE 2 (rotation)

The phase angle (or rotation) of the eddy current signal is set using the **ANGLE 2** function. By default, the angle is set in 1 degree increments, from 0 degrees to 359 degrees.

To adjust the angle setting, press the MAIN FILTER menu key (✂) twice, followed by the B key. With **ANGLE 2** highlighted, rotate the knob until the desired angle is displayed.

TIP

To adjust the angle more precisely, press the Enter key (✓) once while the **ANGLE** function is highlighted to enable the fine-knob function. **ANGLE** will be underlined when this function is enabled. The angle can then be changed in 0.1 degree increments. To turn off the fine-knob function, press ✓ one more time.

GAIN 2

Gain 2 is adjustable from 0.0 dB to 100.0 dB. The displayed gain setting is adjusted in 0.1 dB steps.



Gain 2 can be adjusted independently in the horizontal or vertical direction or in both directions simultaneously. The primary method of adjusting gain is by turning the knob. However, gain may also be adjusted by using the knobless function (see “Knobless Entry” on page 84 for more details).

To adjust the horizontal and vertical gain (**H GAIN 2** and **V GAIN 2**) simultaneously, press the MAIN FILTER menu key (✂) twice, followed by the C key. The gain may then be adjusted with the knob. The selected value will be applied to both the horizontal and the vertical gain, and the difference between

the horizontal and vertical gains will remain constant; they will increase or decrease at the same rate.

To adjust the horizontal gain only (**H GAIN 2** without changing **V GAIN 2**), press the MAIN FILTER menu key () twice, followed by the D key. The knob will then adjust only the horizontal gain. To adjust only the vertical gain (**V GAIN 2**), press the E key. The knob will then adjust only the vertical gain.

TIP

To speed up the gain selection process (while the combined horizontal and vertical gain, horizontal gain, or vertical gain function is highlighted), press  once, which enables the coarse-knob function. **GAIN**, **H GAIN**, or **V GAIN** will be underlined when this function is enabled. The gain can then be changed in 1.0 dB increments. To turn off the coarse-knob function, press  one more time, which returns to gain adjustments in 0.1 dB increments.

4.4.3 MIX Menu in Dual Frequency — MAIN FILTER Key

MIX menu

The **MIX** menu determines how the signal is displayed while in dual frequency. The options are **AUTO**, **F1+F2** (frequency 1 + frequency 2), or **F1-F2** (frequency 1 – frequency 2).

To adjust the **MIX** setting, press the MAIN FILTER menu key () three times, followed by the A key. With **MIX** highlighted, rotate the knob until the desired **MIX** is displayed:

- **AUTO MIX**
- **H MIX GAIN**
- **V MIX GAIN**
- **MIX ANGLE**

When the **MIX TYPE** is set to **AUTO**, the **AUTO MIX** command (B key) becomes available. The **AUTO MIX** command will perform automatic mixing of the live signals when the key is pressed. This function is particularly suited for heat exchanger tubing inspection.

4.4.4 Filter Menu in Dual Frequency — MAIN FILTER Key

HI PASS filters

High-pass filters may be set from 0 Hz (**OFF**) to 100 Hz in 1 Hz increments, and from 100 Hz to 1000 Hz in 5 Hz increments. To adjust the **HI PASS** filter settings, press the MAIN FILTER menu key () three times, followed by the A key, and then rotate the knob to the desired value.

LO PASS filters

Low-pass filters may be set from 10 Hz to 100 Hz in 1 Hz increments, up to 500 Hz in 5 Hz increments, and up to 2000 Hz in 25 Hz increments, followed by wide band. To adjust the **LO PASS** filter settings, press the MAIN FILTER menu key () three times, followed by the B key, and then rotate the knob to the desired value.

CONT NUL (continuous null)

CONT NUL allows a very low-frequency high-pass filter to be turned on, which is useful to keep the null point of the eddy current probe at the specified point, if required. When turned on, this function adds a 0.2 Hz, 0.5 Hz, or 1 Hz high-pass filter. By default, this feature is set to **OFF**.

To turn on continuous null, press the MAIN FILTER menu key () three times, followed by the C key, and then rotate the knob to the desired value.

SCAN RPM (NORTEC 600S and NORTEC 600D models only)

The **SCAN RPM** function controls the scanner rotational speed (revolutions per minute) when an optional rotating scanner is connected to the NORTEC 600S (N600S) or NORTEC 600D (N600D) instrument models.

To adjust the **SCAN RPM** setting, press the MAIN FILTER menu key () three times, followed by the E key, and then rotate the knob to the desired value.

4.4.5 Special Menu in Dual Frequency — MAIN FILTER Key

PRB DRV (probe drive)

The NORTEC 600 instrument has three levels of probe drive that can be selected: **LOW**, **MEDIUM**, and **HIGH**. The approximate peak-to-peak voltages are 2 V, 6 V, and 12 V, respectively.

MID probe drive (the default setting) is normally sufficient for most eddy current testing. However, **HIGH** probe drive is desirable in the following cases:

- a) If gain is insufficient at the lower probe-drive settings.
- b) During testing of lower conductivity materials.
- c) For finding smaller flaws in the test material.
- d) For deeper penetration into the test material.

To adjust the probe drive level, press the MAIN FILTER menu key () four times, followed by the A key. With the **PRB DRV** function highlighted, rotate the knob to the desired level.

PRB CONN (probe connection)

The NORTEC 600 instrument supports two types of probe connections: BNC and 16-pin LEMO. The probe input by default is set to 16-pin LEMO. If the BNC connector is used the connection input needs to be changed manually.

To adjust the probe-connection input, press the MAIN FILTER menu key () four times, followed by the B key. With **PRB CONN** highlighted, rotate the knob to select the desired connector: **LEMO-16** or **BNC**.



SIG TYPE

SIG TYPE (signal type—absolute or differential) is displayed only when using an adapter compatible with one of the six heat exchanger tubing applications (see “Heat Exchanger Tubing Applications” on page 234).

Slide Rule

The NORTEC 600 instrument includes a useful slide-rule tool for determining the standard depth of penetration for a given material at a specified frequency. The user can select a material from the list or enter a specific conductivity value.

The slide-rule tool can also determine the necessary frequency for a given depth of penetration. The separation angle is assumed to be 118 degrees for this calculation.

To access the slide-rule menu, press the MAIN FILTER menu key () four times, followed by the E key. When the **EDDY CURRENT SLIDE RULE** menu is displayed, use the FULL NEXT key () to navigate the menu functions. Additional navigation instructions and information are displayed in the help text at the bottom of the screen (see Figure 4-12 on page 93).

4.4.6 Display Menu in Dual Frequency — DISP Key

The display menu contains menus to control various functions such as **DSP MODE** (display mode) **CHANNEL**, **POSITION**, **H POS** and **V POS** (horizontal and vertical position), **D ERASE** (display erase), **PERSIST**, **GRID**, and **ZOOM**.

DSP MODE (display mode)

When dual frequency is enabled, five display modes are available on the NORTEC 600 instrument: **IMP** (impedance), **ALL-IN-1** (all in one), **DUAL IMP** (dual impedance, also named “split screen”), **SWP + IMP** (sweep + impedance) and **SWEEP**.

To choose the **DSP MODE** (display mode), press the DISP menu key () followed by the A key. With **DSP MODE** highlighted, rotate the knob to select the desired mode.

IMP (impedance)

Impedance mode is the most common display mode. It incorporates a 10×10 grid configuration on the screen. The eddy current signal is shown moving horizontally and vertically.

ALL-IN-1

ALL-IN-1 mode is used to display the signal traces associated with both **FREQ 1**, **FREQ 2**, and the **MIX** signal at the same time, each with a different color to show how the individual signals interact.

DUAL IMP (dual impedance)

Dual impedance (split screen) mode divides the instrument screen into two impedance displays with channel 1 on the left and channel 2 on the right. The dual impedance screen is used to set up dual frequencies, and it displays **FREQ 1** (frequency 1) and **FREQ 2** (frequency 2).

SWP + IMP (sweep + impedance)

Sweep + impedance mode is similar to dual impedance mode except that the instrument sweep display is shown on the left screen and the impedance display on the right. As with the **DUAL IMP** (dual impedance) mode, it is used to set up dual frequencies, and it displays **FREQ 1** (frequency 1) and **FREQ 2** (frequency 2).

SWEEP

Commonly used with rotating scanners. The eddy current signal is shown moving horizontally at a fixed rate across the screen. In dual frequency mode,

however, the user can choose between displaying channel 1 (**FREQ 1**), channel 2 (**FREQ 2**), or the mix signal (**MIX**).

CHANNEL

The Channel function is used to display which signal is being displayed: frequency 1, frequency 2, or Mix.

To choose the **CHANNEL**, or signal displayed, press the DISP menu key () followed by the B key. With **CHANNEL** highlighted, rotate the knob to select the desired signal, **FREQ 1** (frequency 1), **FREQ 2** (frequency 2), or **MIX**.

SWP MODE (sweep mode)

Sweep mode is used to control the instrument's sweep mode, and includes **AUTO Y** and **AUTO XY** for use with rotating scanners. **AUTO Y** contains the external horizontal sync signal and **AUTO XY** contains both the horizontal and vertical external sync signals.

To choose the sweep mode, press the DISP menu key () followed by the C key. With **SWP MODE** highlighted, rotate the knob to select the desired signal: **AUTO Y** or **AUTO XY**.

V POS (vertical position)

Vertical position is used to control the signal trace shown on the instrument screen and is only displayed when **AUTO Y** is selected. By default, the setting is 50 %, or centered on the screen. Choices for this setting range from 0 % (bottom of the screen) to 100 % (top of the screen).

To choose the vertical position, press the DISP menu key () followed by the E key. With **V POS** highlighted, rotate the knob to select the desired position.

H POS

Changes the null position in the horizontal axis. To change the horizontal position, press the DISP menu key () followed by the D key. With **H POS** highlighted, rotate the knob to select the desired position.

GRID

Five screen grid types are available: **OFF**, **10 × 10**, **FINE**, **COARSE**, and **WEB**. By default, the NORTEC 600 instrument uses a 10 × 10 grid.

To choose the grid to be displayed, press the DISP menu key () twice, followed by the D key. With **GRID** highlighted, rotate the knob to select the desired grid.

SWP ERS (sweep erase)

Sweep erase is used to control when the sweep signal is erased. The choice is **ON** (default) or **OFF**. When the sweep erase is enabled (**ON**) the sweep signal is automatically erased before the next sweep signal is provided, and the signal on the screen is constantly updated. If **SWP ERS** is disabled, the screen is only erased if the ERASE direct-function key () is pressed.

To choose when the sweep signal is erased, press the DISP menu key () twice, followed by the E key. With **SWP ERS** highlighted, rotate the knob to select **ON** or **OFF**.

4.4.7 ALARM Menu in Dual Frequency — ALARM Key

In dual frequency mode, the alarm menus are chosen and defined in the same manner as single frequency except more functions are available for the additional second frequency. For more information on setting the alarms in dual frequency mode, see “Alarm Menus” on page 298.

5. Using the Instrument

This chapter explains how to use the NORTEC 600 instrument for inspections and conductivity measurements and provides details on the instrument alarms.

The application examples in this chapter have been prepared to help you rapidly obtain the best results for the most common NORTEC 600 applications. Although it may be possible to obtain equivalent results using different methods, it is recommended that you follow these examples to most efficiently learn how to take full advantage of the instrument's numerous features. This minimizes the required number of steps and operations. The example procedures are also a good starting point if you need to write any inspection procedures based on the NORTEC 600.

IMPORTANT

The application examples presented here are not intended to replace any original equipment manufacturer (OEM) inspection procedures for your specific applications. Instead, they are intended to help you benefit from the numerous features available on the NORTEC 600. This facilitates the configuration of commonly used eddy current applications and provides you with self-guided training. You must ALWAYS closely follow your own OEM procedures.

NOTE

Certain Evident probes, scanners or accessories use PowerLink technology. To fully benefit from the NORTEC 600 instrument's pre-programmed features, it is recommended that you choose an application from the application selection menu after your PowerLink probe or accessory is connected and accepted by the instrument.

5.1 Common NORTEC 600 Applications

This section contains example procedures for commonly used applications.

5.1.1 Detecting Surface-Breaking Cracks — General Purpose Procedure for All NORTEC 600 Models

The steps in this procedure are based on the use of a reference standard made of aluminum. However, very similar steps can be followed when inspecting any other metals, including ferromagnetic materials.

Inspection materials are shown in Figure 5-1 on page 126.

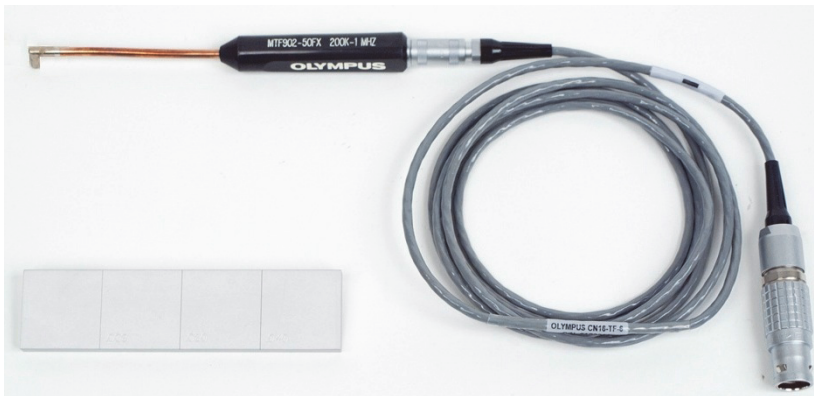



Figure 5-1 Materials—surface-breaking cracks

The following products are used in this procedure:

- Right angle flexible metal shaft surface probe: 12.7 cm (5 in.) overall length and 5 mm (0.20 in.) drop (90° bend) at tip; operating frequency 200 kHz to 1 MHz, triaxial Fischer/LEMO connector, bridge coil configuration; P/N: MTF902-50FX 200K-1M [U8616220]
- Cable: 1.83 m (6 ft) length, bridge coil configuration, 16-pin LEMO to Fischer/LEMO triaxial (SPO-6472); P/N: 9122244 [U8800091]
- Surface reference standard with certification: aluminum material with EDM notch depths of 0.203 mm (0.008 in.), 0.508 mm (0.020 in.) and 1.016 mm (0.040 in.), and

maximum width of 0.178 mm (0.007 in.); block overall dimensions
25.4 mm×101.6 mm×6.35 mm (1 in.×4 in.×0.25 in.); P/N: SRS-0824A [U8860536]

To set the initial NORTEC 600 configuration

1. Connect the probe and cable to the PROBE connector on the NORTEC 600.
2. Press the ADV SETUP menu key () once, followed by the A key (**APPL SELECT**) to open the application selection menu. Select **Surface Cracks** with the knob (SmartKnob), and then press  to accept (see Figure 5-2 on page 127).

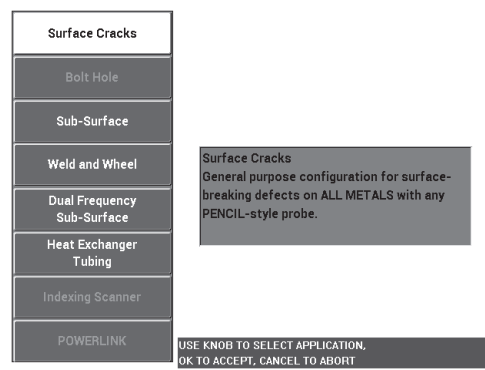



Figure 5-2 The Surface Cracks application

3. Press the DISP menu key () once, and set the **POSITION** (C key) to **BOT CNTR** with the knob.

To calibrate the signals

1. Press the MAIN FILTER menu key () once, and set the **FREQ** (A key) to 500 kHz with the knob.

Depending on the probe that is used to follow this procedure, you may need to select a different frequency.

IMPORTANT

When single-coil absolute probes are connected to the BNC connector, it is important to set the NORTEC 600 accordingly. Repeatedly press the MAIN FILTER menu key

() until the **SPECIAL** menu page is displayed. Set the **PRB CONN** parameter (B key) to **BNC** with the knob. It is also recommended to set the low-pass filter to

100 Hz: press the MAIN FILTER menu key () twice, and set **LO PASS** (B key) to **100 Hz** using the knob.

2. Place the probe coil on the reference standard between two notches, with the

notches facing up, and then press and hold the A-LIFT NULL key () on the NORTEC 600 to activate the automatic lift-off function.

After a brief moment, the NORTEC 600 beeps and displays **LIFT PROBE** at the top of the screen. When this text is displayed, lift the probe into the air, and wait for the message to disappear.

3. Repeat step 2 until you become familiar with the automatic lift-off function.

It may take some practice to obtain the proper timing with the automatic lift-off function, but once mastered, this function will help you obtain a faster calibration.

4. Place the probe between two notches on the reference standard again, press the

A-LIFT NULL key () , and then, after the nulling operation is finished, scan the standard.

The screen should resemble the image shown in Figure 5-3 on page 129.

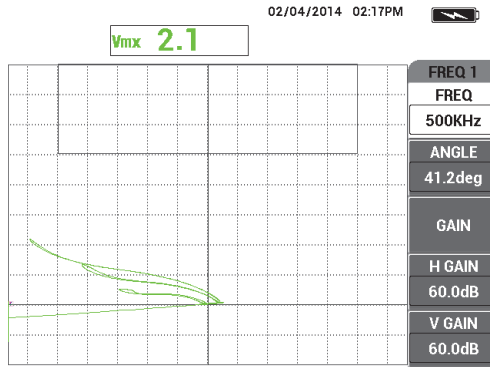

Figure 5-3 The automatic lift-off function

5. Press the FREEZE key (❄️).
You can now use both of your hands to complete the calibration.
6. Press the ANGLE key (◁⊕). The **ANGLE** parameter defaults to the coarse mode. Press the Enter key (✓) in order to switch the **ANGLE** parameter to the fine mode. Adjust the **ANGLE** value with the knob until the lift-off signal is as close as possible to horizontal (see Figure 5-4 on page 129).

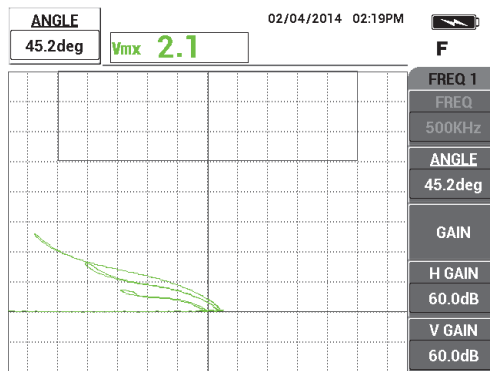

Figure 5-4 The lift-off signal as close as possible to horizontal

7. Press the GAIN key (**dB**) twice to display **H GAIN** in the upper-left corner of the screen, and then decrease the horizontal gain with the knob until the signal from the larger notch is about 3 divisions away from the crosshairs (see Figure 5-5 on page 130).

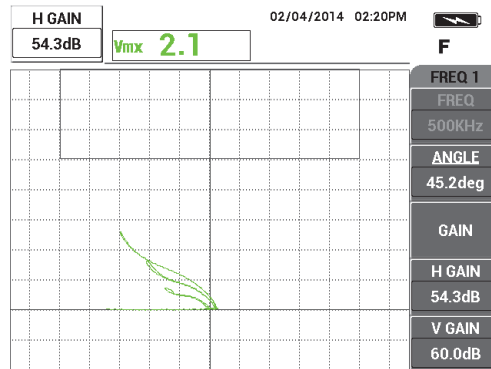

Figure 5-5 Adjusting the horizontal gain

8. Press the GAIN key (**dB**) to display **V GAIN** in the upper-left corner of the screen, and then increase the vertical gain until one of the notches reaches the top of the screen.

In the example shown in Figure 5-6 on page 130, the signal from the bigger notch is set to the last vertical division, which is equivalent to 90 % screen height.

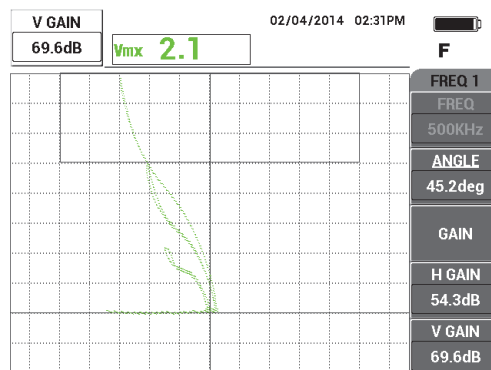

Figure 5-6 Adjusting the vertical gain

9. Press the FREEZE key (❄) to unfreeze the instrument, place the probe on the standard, press the A-LIFT NULL key (⊕), and then scan the standard to perform a final calibration check (see Figure 5-7 on page 131).
If the signals are not satisfactory, repeat steps 5–8.

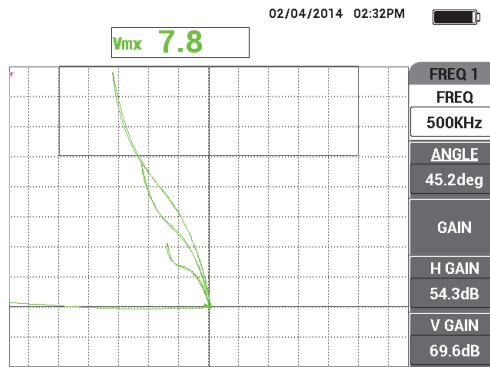

Figure 5-7 The final calibration check

To fine-tune the instrument settings

- Depending on your requirements, set the alarm parameters, horn, or external horn (louder).
For more details about alarms, see “Alarm Menus” on page 298.
- Depending on your requirements, set the display erase or persistence values to automatically refresh the screen.
For more details about screen erase options, see “D ERASE (display erase)” on page 95 and “PERSIST (variable persistence)” on page 95.
- Press the FULL NEXT key (➡) to toggle to the full-screen mode, and then scan the standard.
The results should resemble the image in Figure 5-8 on page 132. The list of all parameters is shown in Figure 5-9 on page 132.
Note that the value of the maximum vertical amplitude is displayed by default in the bottom-right corner. For more details about the reading type or position in the impedance plane display, see “Displaying Real-Time Readings” on page 62.

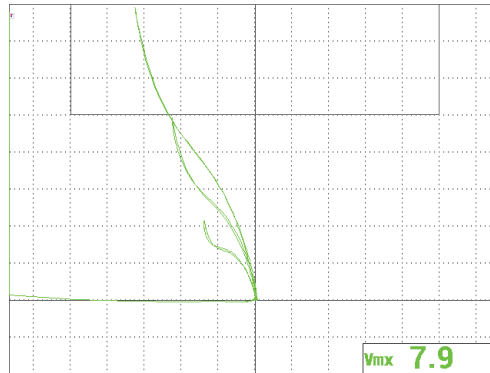

Figure 5-8 The full-screen mode for fine-tuning the settings

SINGLE FREQUENCY			
FRQ MODE	SINGLE	FREQ	500KHz
ID	No Probe	ANGLE	45.2deg
SERIAL #	No Probe	H GAIN	54.3dB
PRB CONN	LEMO-16	V GAIN	69.6dB
PRB DRV	MEDIUM	H POS	50%
HI PASS	OFF	V POS	20%
LO PASS	500Hz	SHAPE 2	SECTOR
CONT NUL	OFF	OUTR DIA	90%
DSP MODE	IMP	INNDR DIA	35%
GRID	FINE	STRT ANG	10deg
PERSIST	OFF	END ANG	130deg
D ERASE	OFF	SHAPE 3	SWEEP
SWP ERS	ON	TOP	70.0%
SWP MODE	AUTO Y	BOTTOM	30.0%
SWP TIME	0.300sec	W START	1
SYNC ANG	0deg	W END	32
SCAN RPM	ORPM	W ERASE	MANUAL
		W CURSOR	1

SINGLE FREQUENCY			
ALARM 1	FRQ1 POS	RDG1 TYP	VMAX
ALARM 2	OFF	RDG1 LOC	BOT RIGHT
ALARM 3	FRQ1 NEG	RDG2 TYP	OFF
		RDG2 LOC	TOP RIGHT
		TIME WIN	0.5sec
HORN	OFF	CAP MODE	INSTANT
DWELL	0.0sec	CAP DLY	5.0sec
EXT HORN	ON	AOUT PWR	OFF

PRESS [A] FOR FIRST COL, [B] FOR SECOND COL, [C] FOR THIRD COL, [E] FOR NEXT. PRESS [A] FOR FIRST COL, [B] FOR SECOND COL, [E] FOR PREV.

Figure 5-9 The list of all parameters

5.1.2 Inspecting Fastener Holes with a Rotating Scanner — NORTEC 600S and NORTEC 600D Models

This procedure is intended for the general-purpose inspection of aircraft fastener holes in aluminum material, and has been prepared for a 12.70 mm (0.50 in.) diameter hole. At the end of this section, more details are provided for ferromagnetic (steel) material hole inspection as well as the new NORTEC 600's Figure 6 versus Figure 8 filter response.

Inspection materials are shown in Figure 5-10 on page 133.



Figure 5-10 Materials—fastener holes with rotating scanner



The following products are used in this procedure:

- MiniMite Fischer rotating scanner; P/N: 9744738 [U8750012]
- Rotary-hole probe: self-adjusting, Universal type, with Bell backshell, 12.70 mm (0.500 in.) diameter, self-expanding, 50.8 mm (2 in.) working length; operating frequency 200 kHz to 3 MHz, Fischer 4-pin connector, reflection differential coil configuration; P/N: SUB-28-32 [U8600488]
- Eddy current hole standard for demonstration purposes (not certified); P/N: RSTD-10135 [U8863213]

To set the initial NORTEC 600 configuration

1. Connect the probe to the rotating scanner (align the red marks on the connectors), and connect the scanner cable to both the rotating scanner and the NORTEC 600 PROBE connector.
2. When prompted, select **CONTINUE** (A key) to accept the PowerLink settings.
3. Select the application:
 - ◆ If you are using software version 1.09 or higher, the application selection menu automatically opens. Select **Bolt Hole** with the knob, and then press ✓ to accept.

OR

If you are using an earlier version of the software, press the ADV SETUP menu key () once, and then select **APPL SELECT** (A key) to open the application selection menu. Select **Bolt Hole** with the knob, and then press  to accept (see Figure 5-11 on page 134).

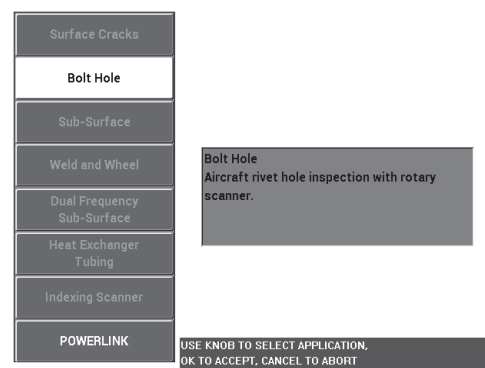



Figure 5-11 The Bolt Hole application

To calibrate the signals

1. Insert the probe into the “bad” hole on the standard (there are two 12.70 mm [0.50 in.] holes: one without defects and one with a long axial notch), making sure to properly align the probe with the hole, and then press the A-LIFT NULL key ().

Note that the scanner should be stopped when nulling the instrument.

2. Hold the probe in the hole and properly aligned on the long crack. If this is your first scan, start the rotating scanner motor by pressing the switch at the back of the rotating scanner.

The signal on the impedance plane (right side) should display the defect signal and the lift-off signal (also referred to as the probe-motion signal). Depending on the probe diameter used, the lift-off signal may appear smaller or bigger, and sometimes the signal may be difficult to see on the screen.

If the probe is correctly aligned in the hole, the lift-off amplitude is normally decreased, but if the probe is slightly misaligned, it will result in an increase in

lift-off signal. However, make sure that you do not tilt the probe too much, since this could cause damage (see Figure 5-12 on page 135).

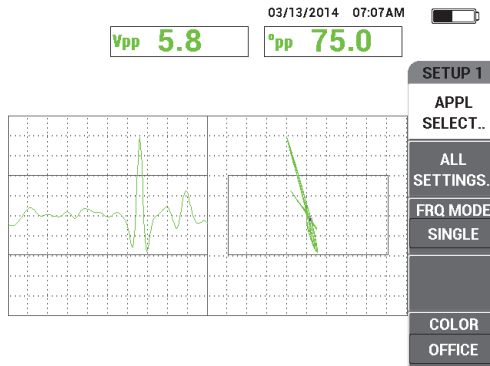



Figure 5-12 The bolt-hole signal

3. Set the signal angle according to one of the following two alternative methods. Before proceeding, check which method is better suited to your needs:

- First alternative:

While holding the probe (still rotating) in the bad hole, press the ANGLE key () and then adjust the angle with the knob in order to rotate the lift-off noise to a horizontal position (see Figure 5-13 on page 135).

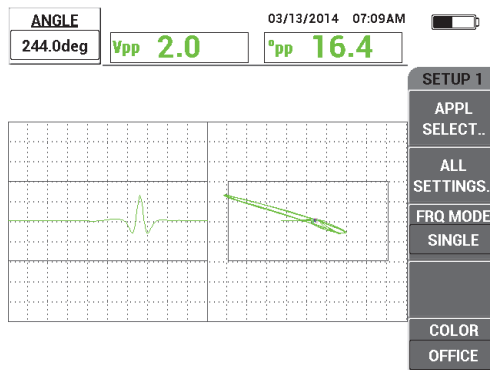

Figure 5-13 Adjusting the lift-off noise (first alternative)

— Second alternative:

If the surface of your sample is made of the same material as the material of the hole to be inspected, this alternative is usually more practical and easier. While the scanner is rotating the probe, simply gently touch the surface of the sample with the head of the probe, and adjust the signal angle so that the tip of the signal extends to the right of the impedance plane (see Figure 5-14 on page 136).

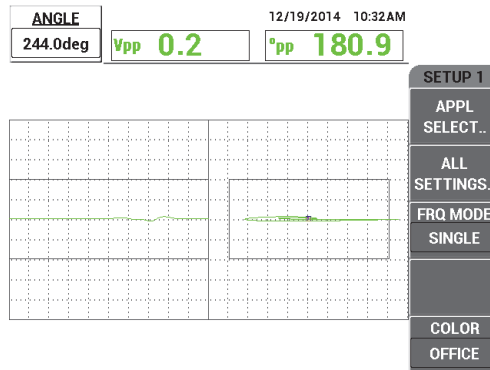

Figure 5-14 Adjusting the lift-off noise (second alternative)

4. Press the GAIN key (**dB**), and then decrease the gain with the knob in order to keep the entire crack signal within the screen area.

A good practice is to set the signal's maximum deflection to 10 % of the screen's horizontal deflection (see Figure 5-15 on page 137).

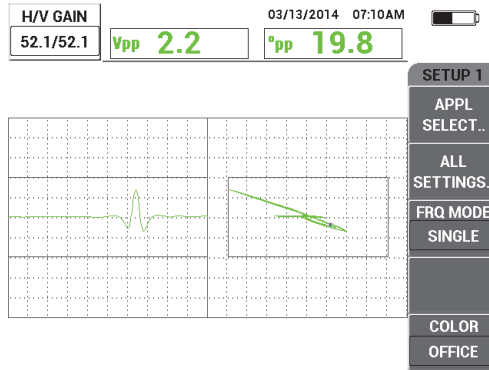

Figure 5-15 Adjusting the gain

5. Press the GAIN key (**dB**) two more times to access the **V GAIN** parameter, and then adjust the vertical gain with the knob until the signal reaches the top of the screen, which is 100 % screen height (see Figure 5-16 on page 137).

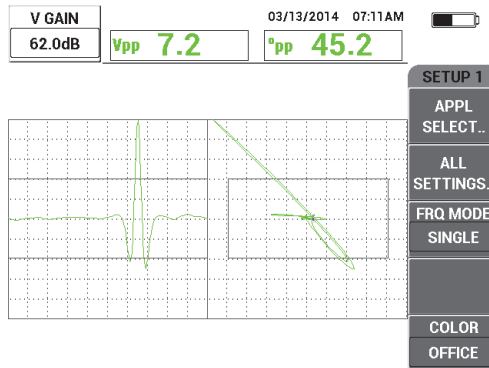



Figure 5-16 Adjusting the vertical gain

At this point, the configuration is nearly finished.

6. If required, fine-tune the filter values by pressing the MAIN FILTER menu key () twice to access the **HI PASS** (A key), **LO PASS** (B key) or **SCAN RPM** (E key) parameters and adjusting these parameters while maintaining the probe rotating in the bad hole.

Note that the NORTEC 600 features a constant “figure-6” rotating bolt-hole signal response. In theory, filter adjustment is unnecessary, and only the scanner speed (**SCAN RPM**) needs to be adjusted.

7. If the flaw appears at an inconvenient location in the sweep (strip chart) view on the left, press the DISP menu key () and adjust the **SYNC ANG** (D key) with the knob until it is in a satisfactory location.

To fine-tune the instrument settings for aluminum

1. Depending on your requirements, set the alarm parameters, horn, or external horn (louder). For more details about alarms, see “Alarm Menus” on page 298.
2. Check if any other display modes, such as the **IMP** and the **WATERFALL** display modes, might be useful for your purposes. For more details about screen options, see “Display Menu – DISP Key” on page 93 and “Display Menu in Dual Frequency – DISP Key” on page 122.
3. Press the FULL NEXT key () to toggle to the full-screen mode, and then insert the probe into the bad hole.

The results should resemble the image in Figure 5-17 on page 138. The list of all parameters for aluminum is shown in Figure 5-18 on page 139.

Note that the value of the maximum signal amplitude and signal angle is displayed by default. For more details about the readings or their position in the impedance plane display, see “Displaying Real-Time Readings” on page 62.

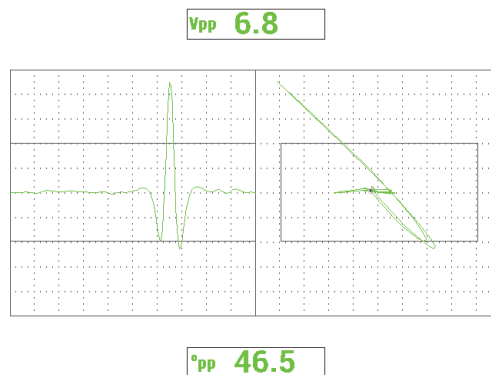

Figure 5-17 The full-screen mode for fine-tuning the settings

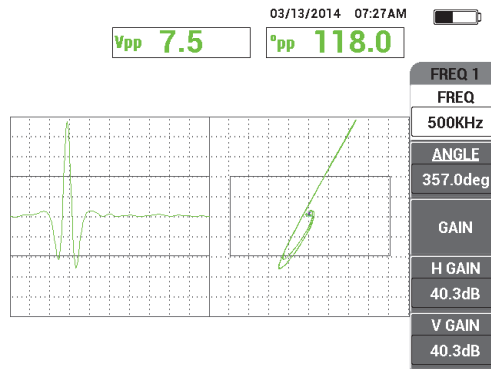

Figure 5-19 An example display for a steel hole

SINGLE FREQUENCY			
FREQ MODE	SINGLE	FREQ	500KHz
ID	MINIMITE-F	ANGLE	357.0deg
SERIAL #	946	H GAIN	40.3dB
PRB CONN	LEMO-16	V GAIN	40.3dB
PRB DRV	MEDIUM	H POS	50%
HI PASS	125Hz	V POS	50%
LO PASS	400Hz	SHAPE 2	SWEEP
CONT NUL	OFF	TOP	70.0%
DSP MODE	SWP+IMP	BOTTOM	30.0%
GRID	10X10	LEFT	10.0%
PERSIST	OFF	RIGHT	90.0%
D ERASE	0.1sec	SHAPE 3	POLAR
SWP ERS	ON	RADIUS	25.0%
SWP MODE	EXT Y	HORZ	50.0%
SWP TIME	0.010sec	VERT	50.0%
SYNC ANG	0deg	W START	1
SCAN RPM	1500RPM	W END	32
		W ERASE	MANUAL
		W CURSOR	1

SINGLE FREQUENCY			
ALARM 1	FRQ1 NEG	RDG1 TYP	VPP
ALARM 2	FRQ1 NEG	RDG1 LOC	TOP CNTR
ALARM 3	OFF	RDG2 TYP	DEG PP
		RDG2 LOC	BOT CNTR
		TIME WIN	0.5sec
HORN	OFF	CAP MODE	INSTANT
DWELL	0.0sec	CAP DLY	5.0sec
EXT HORN	ON	AOUT PWR	OFF

PRESS [A] FOR FIRST COL, [B] FOR SECOND COL, [C] FOR THIRD COL, [E] FOR NEXT.

PRESS [A] FOR FIRST COL, [B] FOR SECOND COL, [E] FOR PREV.

Figure 5-20 The list of all parameters in ferromagnetic material

Filter Type — Figure 6 or Figure 8 Signals

The most recent digital filtering technology used on the NORTEC 600 includes improvements to the filter system. The NORTEC 600 features a new parameter, named **FILT TYP** (filter type), which is accessed using the C key—after pressing the

MAIN FILTER menu key () three times. This parameter determines the way the signal is distorted (or not distorted) in the impedance plane.

The default filter type is a Figure 6 (FIG 6) signal, which has a needle-like shape and is widely employed in the industry. This Figure 6 filter automatically adjusts the signal phase in order to achieve the typical Figure 6 response, regardless of high and low pass filter settings. This constant Figure 6 filter response enables much quicker and easier tuning of the NORTEC 600 filter system, and it makes it possible to eliminate unwanted signals rather than trying to achieve the proper signal shape.

The Figure 8 (FIG 8) filter type is generated using filters that are almost completely nondistorting. This filter type is useful when using absolute rotating probes or in special engine-inspection applications. The Figure 8 filter is also the default filter type for nonrotating applications such as surface inspection.

Figure 5-21 on page 141 shows the Figure 6 response on the left and the Figure 8 response on the right. Both images have been obtained using the same probe in an aluminum hole with very similar gain and angle settings.

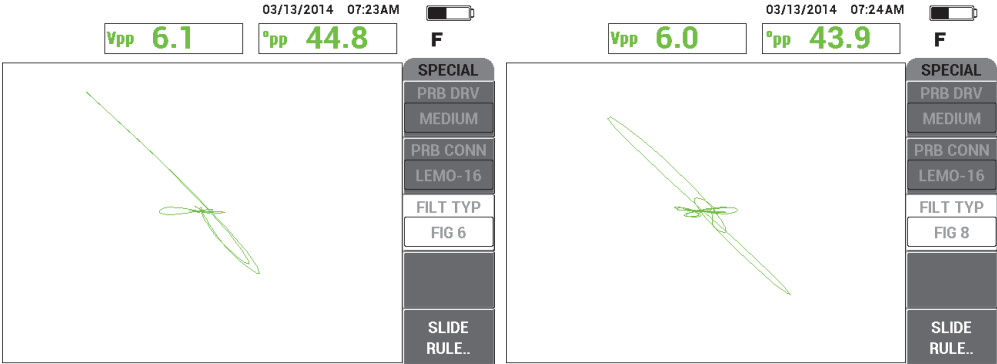

Figure 5-21 Comparing the Figure 6 (left) and Figure 8 filter signals

By setting LINK to ON, you can enable the dynamic high and low pass filter settings while you adjust RPM to maintain the signal response.

5.1.3 Detecting Sub-Surface Cracks at Very Low Frequency — All NORTEC 600 Models

This section contains a general procedure for detecting sub-surface cracks at fastener locations in aircraft lap joints. This procedure can easily be adapted to thicker skins (or materials) by employing a bigger ring probe and lower frequency.

Inspection materials are shown in Figure 5-22 on page 142.

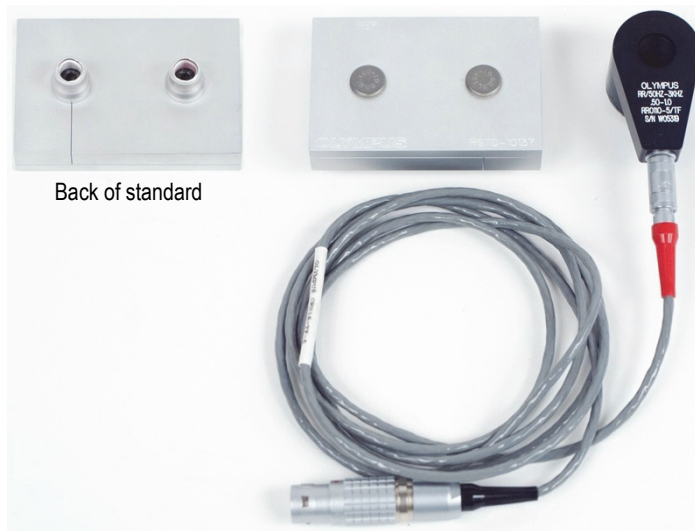



Figure 5-22 Materials—sub-surface cracks at very low frequency

The following products are used in this procedure:

- Reflection-ring probe with triaxial Fischer/LEMO connector: operating frequency 50 Hz to 3 kHz, 12.7 mm (0.50 in.) ID × 25.4 mm (1.0 in.) OD; P/N: RR110-5/TF 50HZ-3KHZ [U8636011]
- SPO-6687 cable: connects reflection coil configuration probes with triaxial Fischer/LEMO connector to NORTEC 500, 600, 1000 and 2000 Series instrument (16-pin LEMO); 1.83 m (6 ft) length; P/N: SPO-6687 [U8800538]
- Sub-surface crack calibration standard; P/N: RSTD-10137 [U8863219]

To set the initial NORTEC 600 configuration

1. Connect the probe and the cable to the PROBE connector on the NORTEC 600.
2. Press the ADV SETUP menu key (→ ) once, and then select **APPL SELECT** (A key) to open the application selection menu. Select **Sub-Surface** with the knob, then press ✓ to accept (see Figure 5-23 on page 143).

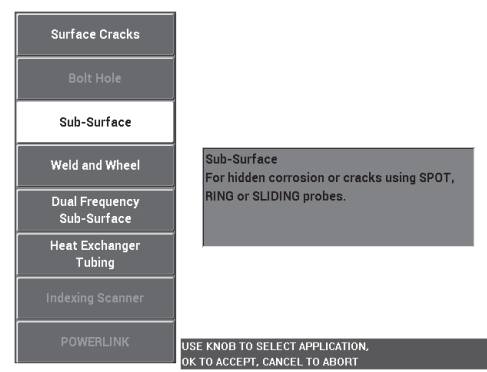





Figure 5-23 The Sub-Surface application

To calibrate the signals

1. Press the MAIN FILTER menu key () once, and then set the **FREQ** (A key) to **220 Hz**.
2. Place the probe directly on the good fastener on the standard, and then press and hold the A-LIFT NULL key () to activate the automatic lift-off function. When **LIFT PROBE** is displayed, lift the probe vertically (try to avoid tilting) and wait for the message to disappear.
3. Repeat step 2 until you become familiar with the automatic lift-off function. It may take some practice to obtain the proper timing with the automatic lift-off function, but once mastered, this function will help you obtain a faster calibration.
4. Place the probe above the good fastener again, and then press the A-LIFT NULL key ().
5. Lift the probe into the air, and then place the probe on the cracked fastener and press the FREEZE key ().

The resulting signal is shown in Figure 5-24 on page 144.

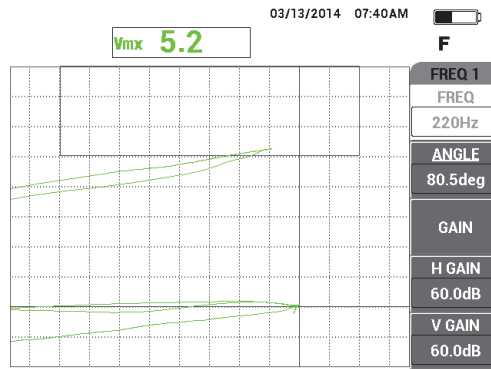



Figure 5-24 The signal on the cracked fastener

- Press the ANGLE key () , and then use the knob to adjust the lower lift-off signal so that it is as close to horizontal as possible (see Figure 5-25 on page 144).

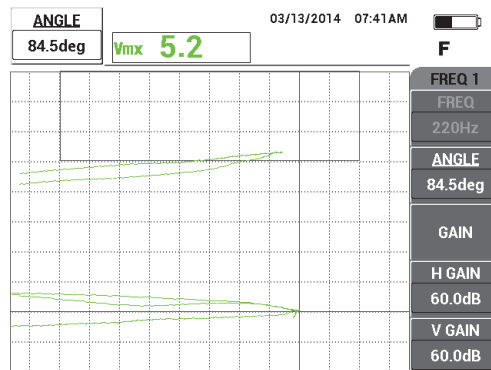

Figure 5-25 The lower lift-off signal as close as possible to horizontal

- Press the GAIN key (**dB**) three times to access the **V GAIN** parameter, and then increase the vertical gain until the signal reaches the last vertical division on the screen, which is equivalent to 90 % screen height (see Figure 5-26 on page 145).

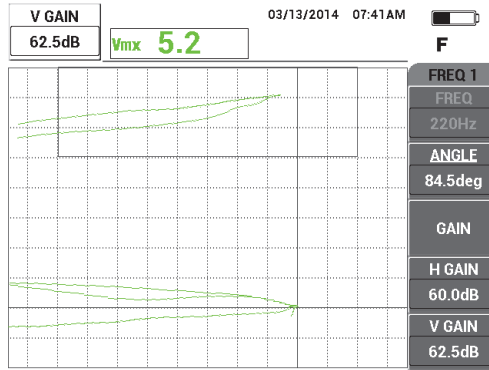

Figure 5-26 Adjusting the vertical gain

8. Press the FREEZE key (❄️) to unfreeze the acquisition, and then press the FULL NEXT key (➡️) to toggle to full-screen mode (see Figure 5-27 on page 145). To test the calibration, place the probe successively on the cracked and uncracked fasteners, and ensure that the cracked fastener generates a vertical deflection. While placing the ring probe, make sure to carefully aim it towards the center of each fastener.

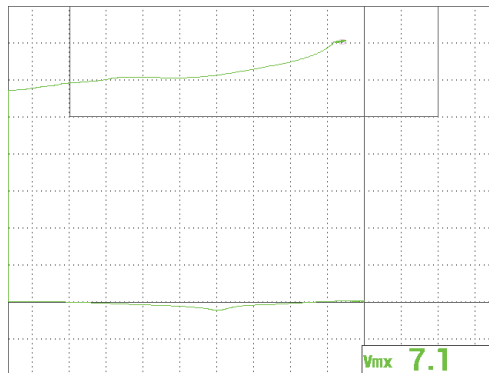

Figure 5-27 The signal in full-screen mode

To fine-tune the instrument settings

1. If you are using a very low frequency probe (typically below 500 Hz), decrease the low-pass setting, which can sometimes help to obtain cleaner signals. Any low-pass value is acceptable.
2. Depending on your requirements, set the alarm box parameters, horn, or external horn (louder). For more details about alarms, see “Alarm Menu” on page 298.
3. Depending on your requirements, set the display erase or persistence values to automatically refresh the screen.

For more details about screen erase options, see “D ERASE (display erase)” on page 95 and “PERSIST (variable persistence)” on page 95.

The list of all parameters is shown in Figure 5-28 on page 146.

SINGLE FREQUENCY			
FRQ MODE	SINGLE	FREQ	220Hz
ID	No Probe	ANGLE	84.5deg
SERIAL #	No Probe	H GAIN	60.0dB
PRB CONN	LEMO-16	V GAIN	62.5dB
PRB DRV	MEDIUM		
HI PASS	OFF		
LO PASS	200Hz	H POS	80%
CONT NUL	OFF	V POS	20%
DSP MODE	IMP		
GRID	FINE	SHAPE 2	SECTOR
PERSIST	OFF	OUTR DIA	100%
D ERASE	OFF	INNER DIA	40%
SWP ERS	ON	STRT ANG	40deg
		END ANG	130deg
SWP MODE	AUTO Y	SHAPE 3	SWEEP
SWP TIME	0.300sec	TOP	75.0%
SYNC ANG	0deg	BOTTOM	25.0%
SCAN RPM	0RPM		
		W START	1
		W END	32
		W ERASE	MANUAL
		W CURSOR	1

SINGLE FREQUENCY			
ALARM 1	FRQ1 POS	RDG1 TYP	VMAX
ALARM 2	OFF	RDG1 LOC	BOT RIGHT
ALARM 3	OFF	RDG2 TYP	OFF
		RDG2 LOC	BOT LEFT
		TIME WIN	0.5sec
HORN	OFF	CAP MODE	INSTANT
DWELL	0.0sec	CAP DLY	5.0sec
EXT HORN	ON	AOUT PWR	OFF

PRESS [A] FOR FIRST COL, [B] FOR SECOND COL, [C] FOR THIRD COL, [E] FOR NEXT. PRESS [A] FOR FIRST COL, [B] FOR SECOND COL, [E] FOR PREV.

Figure 5-28 The list of all parameters

NOTE

With this application, the results are better and interpretation much easier when the signal from the cracked fastener is oriented at 90° with respect to the lift-off signal from the good fastener. Using the proper frequency greatly improves interpretation of the results. Figure 5-29 on page 147 shows examples of calibrations performed with frequencies that were too low (left) and too high (right).

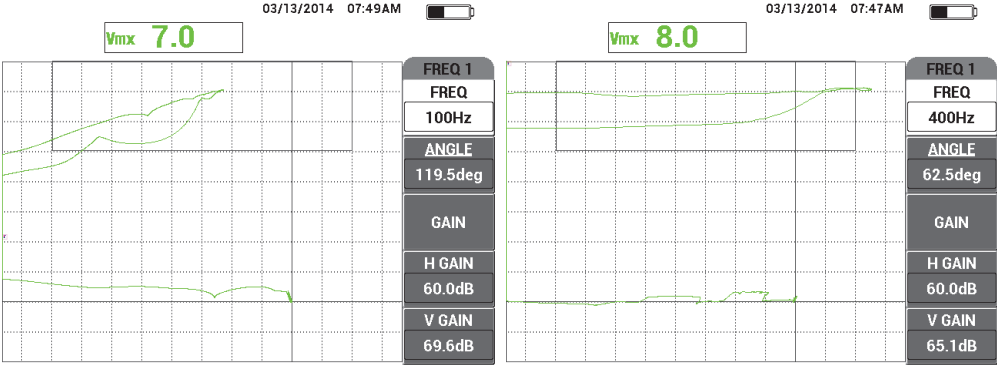

Figure 5-29 Calibration with frequency too low (left) or too high (right)

5.1.4 Inspecting Welds on Ferromagnetic Materials — All NORTEC 600 Models

The procedure in this section is the easiest and most efficient way to perform a general-purpose weld inspection on ferromagnetic material (such as carbon steel) using the NORTEC 600.

Inspection materials are shown in Figure 5-30 on page 147.





Figure 5-30 Materials—welds on ferromagnetic material

The following products are used in this procedure:

- Weld surface probe: 100 kHz to 600 kHz, straight probe, 8.0 mm (0.314 in.) tip diameter, 5.5 cm (2.16 in.) length, 4-pin LEMO connector; P/N: WLD-8-55 [U8690019]
- Cable: 1.83 m (6 ft) length, NORTEC 500, 600, 1000, and 2000 series instruments (16 pin LEMO) to 4 pin LEMO for weld probes (4 pin LEMO); P/N: CN16-4L-6 [U8800276]
- Weld surface reference standard with certifications: steel with EDM notch depths of 0.5 mm, 1.0 mm, and 2.0 mm (0.02 in, 0.04 in., and 0.08 in.); block overall dimensions 25.4 mm × 101.6 mm × 6.4 mm (1 in. × 4 in. × 0.25 in.) with four 0.5 mm (0.0197 in.) nonconductive shims to simulate paint thickness; P/N: SRSM-51020S-WLD [U8860571]

To set the initial NORTEC 600 configuration

1. Connect the probe and the cable to the PROBE connector on the NORTEC 600.
2. Press the ADV SETUP menu key () once, and then select **APPL SELECT** (A key) to open the application selection menu. Select **Weld and Wheel** with the knob, and then press  to accept (see Figure 5-31 on page 148).
3. Press the MAIN FILTER menu key () to display the settings on the right side of the screen.

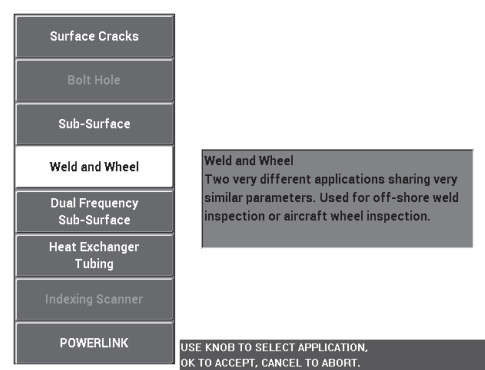

Figure 5-31 The Weld and Wheel application

To calibrate the signals

1. Place the probe between two notches on the standard, position the longest face of the probe tip (see Figure 5-32 on page 149) perpendicularly to the notches, and then press the A-LIFT NULL key (⊕).

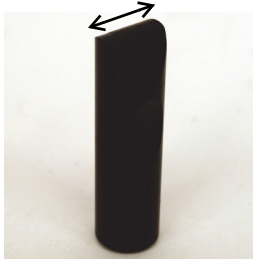



Figure 5-32 The longest face of the probe tip

2. With the longest face of the probe tip oriented perpendicular to the notches, inspect the 1.0 mm (0.04 in.) notch.
 3. Press the FREEZE key (❄).
- The resulting signal is shown in Figure 5-33 on page 149.



Figure 5-33 The signal on the notch

4. Press the ANGLE key () , and then rotate the knob until the notch signal is oriented vertically (see Figure 5-34 on page 150).

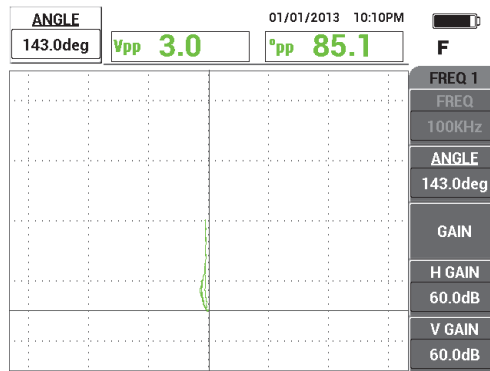

Figure 5-34 The notch signal oriented vertically

5. Press the GAIN key (**dB**) once, and adjust the H/V GAIN until the notch signal reaches about 90 % of the screen height (see Figure 5-35 on page 150).

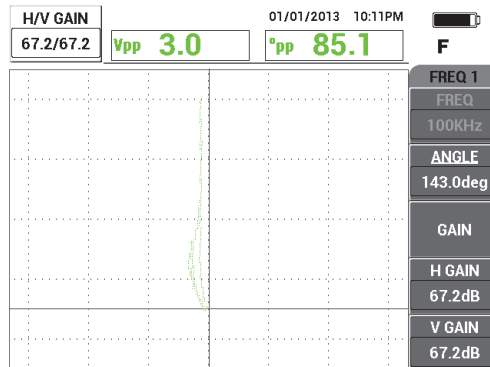





Figure 5-35 Adjusting the vertical gain

6. Press the FREEZE key () to unfreeze the acquisition, press the FULL NEXT key () to toggle to the full-screen mode, place the probe on the standard (the

probe's longest face still parallel to the notches), and then press the A-LIFT NULL key () to scan the entire standard. The resulting signal is shown in Figure 5-36 on page 151.

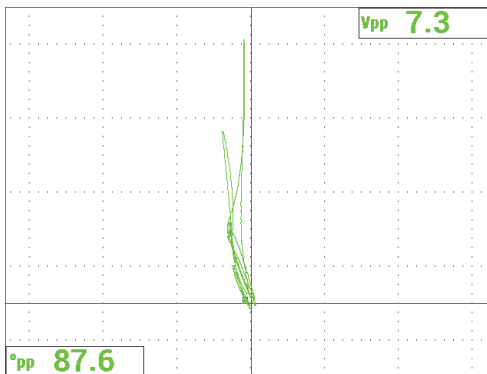

Figure 5-36 The signal after scanning the entire standard

To fine-tune the instrument settings

1. Depending on your requirements, set the alarm parameters, horn, or external horn (louder). For more details about alarms, see “Alarm Menus” on page 298.
2. Depending on your requirements, set the display erase or persistence values to automatically refresh the screen. For more details about screen erase options, see “D ERASE (display erase)” on page 95 and “PERSIST (variable persistence)” on page 95.

You can also check if any other grids and screen display modes might be useful for your purposes; for example, **SWP+IMP**. For more details about screen options, see “Display Menu – DISP Key” on page 93 and “Display Menu in Dual Frequency – DISP Key” on page 122.

3. Confirm that the value of the maximum signal amplitude and signal angle are displayed by default, as shown in the example in Figure 5-37 on page 152. For more details about the reading type or position in the impedance plane display, see “Displaying Real-Time Readings” on page 62.

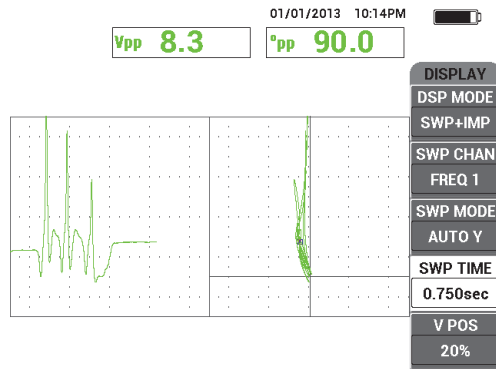

Figure 5-37 The default display of maximum signal amplitude and signal angle

To inspect an actual part (recommended procedure)

1. Check the paint thickness on the part you are inspecting, and calibrate the weld probe using the proper shim thickness that corresponds with the measured paint thickness.
2. Inspect the heat affected zone, the toe of the weld, and the weld cap following the scanning motions shown in Figure 5-38 on page 153.

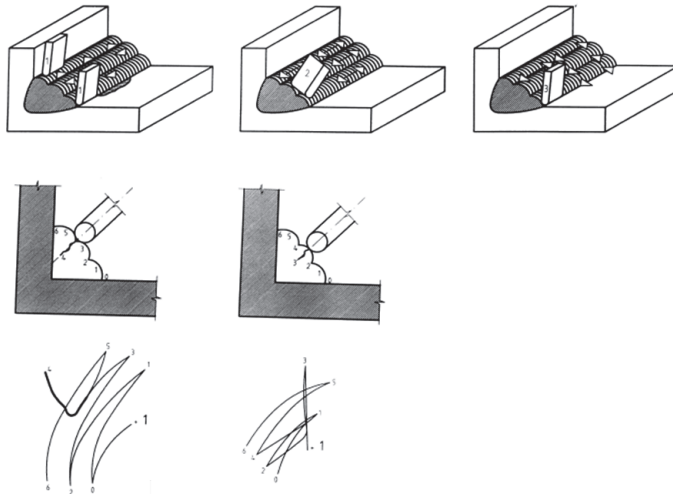
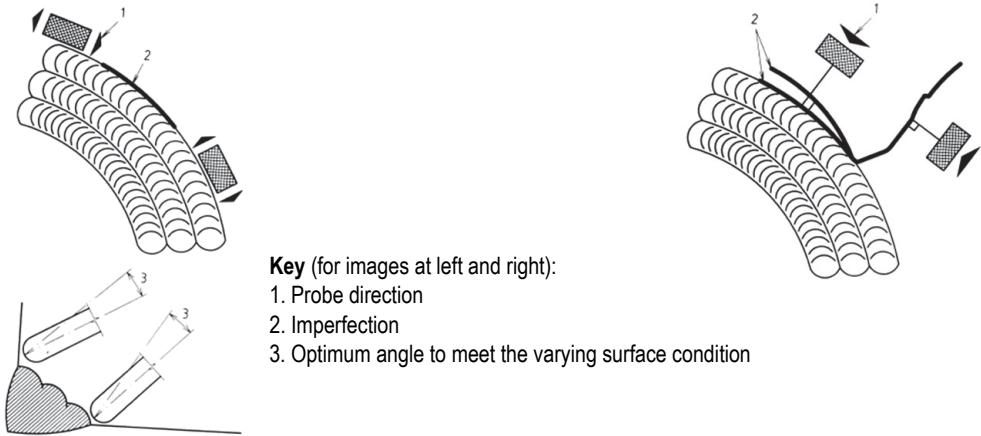

Figure 5-38 The scanning motions

3. Practice your weld inspection; for example, by using an optional weld sample, such as Evident P/N: WLD SAMPLE [U8860581].

The list of all parameters is shown in Figure 5-39 on page 154.



Figure 5-40 Materials—paint thickness on ferromagnetic material

The following products are used in this procedure:

- Paint thickness probe; P/N: NEC-2236 5-250KHZ-2M-4L [U8629568]
- Cable: 1.83 m (6 ft) length, NORTEC 500, 600, 1000, and 2000 series instruments (16 pin LEMO) to 4 pin LEMO for weld probe (4 pin LEMO). P/N: CN16-4L-6 [U8800276]
- Weld surface reference standard with certifications: steel with EDM notch depths of 0.5 mm, 1.0 mm, and 2.0 mm (0.02 in., 0.04 in., and 0.08 in.); block overall dimensions 25.4 mm × 101.6 mm × 6.4 mm (1 in. × 4 in. × 0.25 in.) with four 0.5 mm (0.0197 in.) nonconductive shims to simulate paint thickness; P/N: SRSM-51020S-WLD [U8860571]

To set the initial NORTEC 600 configuration

1. Connect the probe and the cable to the PROBE connector on the NORTEC 600.
2. Press the ADV SETUP menu key (➔ ) once, and then select **APPL SELECT** (A key) to open the application selection menu. Select **Surface Cracks** with the knob, and then press ✓ to accept (see Figure 5-41 on page 156).

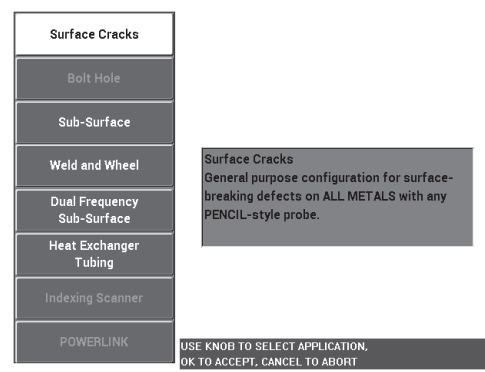







Figure 5-41 The Surface Cracks application

3. Press the MAIN FILTER menu key () once, and then set the **FREQ** (A key) to 10 kHz using the knob.
4. Press the ALARM menu key (), and then deactivate **ALARM 1** (A key).
5. Press the DISP menu key () twice, and then set the **GRID** (D key) to **10 × 10** using the knob.
6. Press the DISP menu key (), and then set the **H POS** (D key) to **100 %** using the knob.
7. Set the **V POS** (E key) to **20 %** using the knob.

To calibrate the signals

1. Place the probe on the standard, between two notches (without any shim), and then press and hold the A-LIFT NULL key () to activate the automatic lift-off function.
After a brief moment, the NORTEC 600 beeps and displays **LIFT PROBE** at the top of the screen. When this text is displayed, lift the probe into the air, and wait for the message to disappear.
2. Repeat step 1 until you become familiar with the automatic lift-off function.
It may take some practice to obtain the proper timing with the automatic lift-off function, but once mastered, this function will help you obtain a faster calibration.

- 3. Place the entire stack of shims (four 0.5 mm shims, or 2.0 mm thickness) on the standard, and then, while firmly pressing the probe on the shim stack, press the GAIN key (**dB**) to decrease the gain until the dot reaches the limit on the left side of the 10 × 10 grid (0 % horizontal) [see Figure 5-42 on page 157].

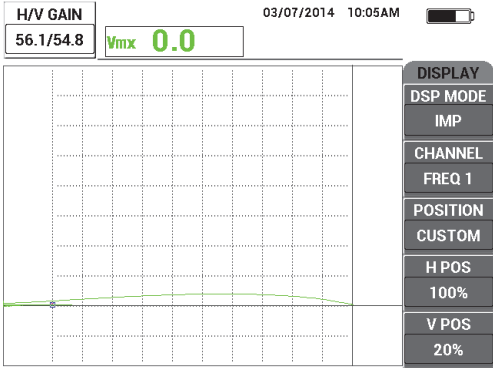

Figure 5-42 Decreasing the GAIN to adjust the signal

- 4. While firmly pressing the probe on the 2.0 mm thick shim stack, increase the V POS (E key) to 100 % using the knob, and then decrease it back to 20 %. The instrument creates a recording in the form of a vertical mark on the screen (see Figure 5-43 on page 157).

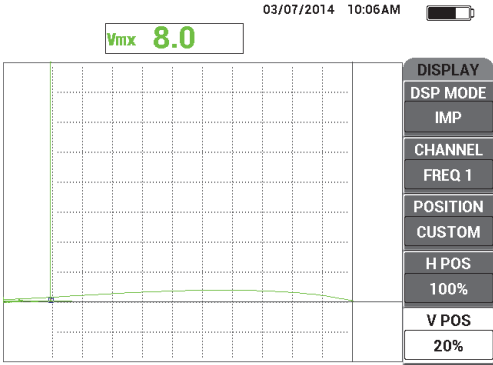

Figure 5-43 Adjusting V POS to create a vertical mark

- Repeat step 4 for each of the other shim thicknesses (1.5 mm, 1.0 mm, and 0.5 mm).

The instrument records a vertical line for each simulated paint thickness (see Figure 5-44 on page 158).

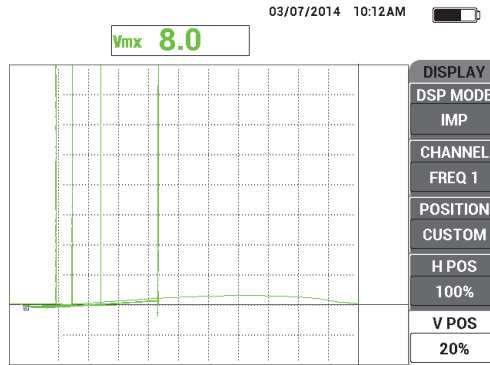



Figure 5-44 The vertical lines for different thicknesses

- Press and hold the REF SAVE key () to set the current signal as the reference signal.
- Set the **V POS** (E key) to **50 %**, and then press the ERASE key ().
- Evaluate your subsequent paint thickness reading using the vertical reference marks (see Figure 5-45 on page 159).

If necessary, you can increase your resolution by calibrating with a greater number of thinner shims.

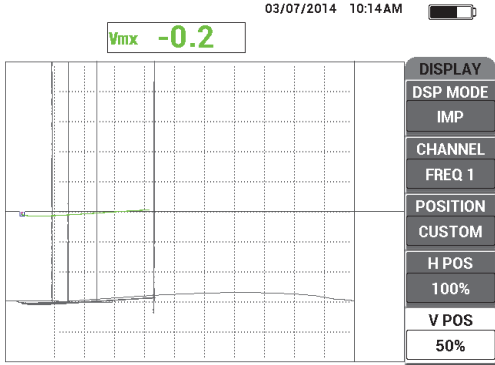

Figure 5-45 Using the vertical reference marks for thickness evaluation

To fine-tune the instrument settings

- ◆ Refer to the list of all parameters, shown in Figure 5-46 on page 159. The default setting for the reading type (**RDG1 TYP**) is **VMAX**, which uses the vertical maximum amplitude. For this procedure, however, it is recommended to select **HMAX**, which uses the horizontal maximum amplitude. For more details about the reading type or position in the impedance plane display, see “Displaying Real-Time Readings” on page 62.

SINGLE FREQUENCY			
FREQ MODE SINGLE	FREQ 10KHz	SHAPE 1 BOX	
ID No Probe	ANGLE 243.2deg	TOP 100.0%	
SERIAL # No Probe	H GAIN 56.0dB	BOTTOM 70.0%	
PRB CONN LEMO-16	V GAIN 54.7dB	LEFT 0.0%	
PRB DRV MEDIUM		RIGHT 100.0%	
HI PASS OFF			
LO PASS 500Hz	H POS 100%	SHAPE 2 SECTOR	
CONT NUL OFF	V POS 50%	OUTR DIA 90%	
DSP MODE IMP		INNR DIA 35%	
GRID 10X10		STRT ANG 10deg	
PERSIST OFF		END ANG 130deg	
D ERASE OFF			
SWP ERS ON		SHAPE 3 SWEEP	
SWP MODE AUTO Y	W START 1	TOP 70.0%	
SWP TIME 0.300sec	W END 32	BOTTOM 30.0%	
SYNC ANG 0deg	W ERASE MANUAL		
SCAN RPM 0RPM	W CURSOR 1		

SINGLE FREQUENCY			
ALARM 1 OFF	RDG1 TYP VMAX		
ALARM 2 OFF	RDG1 LOC BOT RIGHT		
ALARM 3 FRO1 NEG	RDG2 TYP OFF		
	RDG2 LOC TOP RIGHT		
	TIME WIN 0.5sec		
HORN OFF	CAP MODE INSTANT		
DWELL 0.0sec	CAP DLY 5.0sec		
EXT HORN ON	ADUT PWR OFF		

PRESS [A] FOR FIRST COL, [B] FOR SECOND COL, [C] FOR THIRD COL, [E] FOR NEXT. PRESS [A] FOR FIRST COL, [B] FOR SECOND COL, [E] FOR PREV.

Figure 5-46 The list of all parameters

5.1.6 Measuring Conductivity and Nonconductive Coating Thickness — NORTEC 600C, NORTEC 600S, and NORTEC 600D Models

NOTE

The instrument function for measuring conductivity and nonconductive coatings can only be activated by connecting a NORTEC conductivity probe to one of the following NORTEC 600 models: 600C, 600S, and 600D.

The NORTEC 600 instrument automatically detects a PowerLink conductivity probe (16-pin LEMO, 60 kHz, or 480 kHz) when it is connected to the instrument. With this probe type, the instrument reconfigures the operating parameters to permit conductivity measurements. In this operating mode, only the conductivity is displayed. The eddy current signal is not displayed.

Inspection materials are shown in Figure 5-47 on page 160.



Figure 5-47 Materials—conductivity and non-conductive coating thickness

The following products are used in this procedure:

- Conductivity probe: 60 kHz, right-angle probe, 20 mm (0.750 in.) tip diameter, 25.4 mm (1.00 in.) length, 16-pin LEMO connector, Alarm LED included; P/N: 9222340 [U8690027]

- Conductivity standard block with 2 coupons (29.85 % and 59.39 %); P/N: 9522103 [U8880111]
- 4 mil shim samples: 0.1 mm (0.004 in.) thick, set of two; P/N: 0320806 [U8840160]

To set the initial NORTEC 600 configuration

1. Connect the conductivity probe cable to the NORTEC 600 instrument's PROBE connector to access the conductivity function (see Figure 5-48 on page 161).

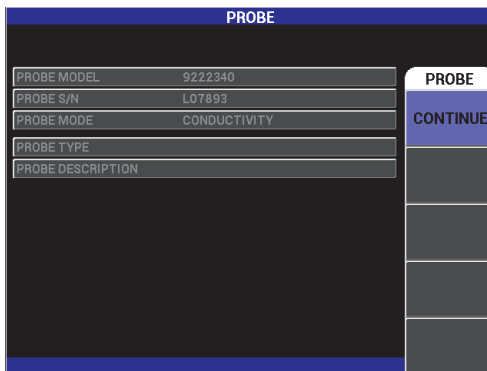

Figure 5-48 Accessing the Conductivity function

2. When prompted, select **CONTINUE** (A key) to accept the PowerLink information (see Figure 5-49 on page 161).

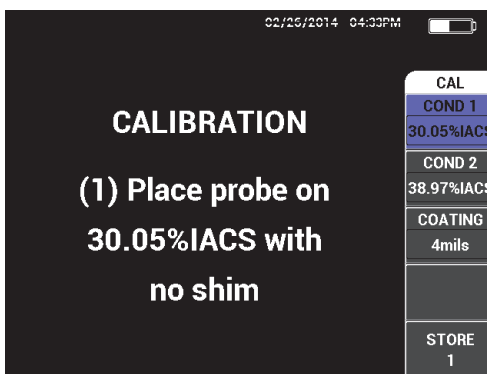

Figure 5-49 The displayed instruction (1) after PowerLink acceptance

To calibrate the signals

IMPORTANT

- To ensure reliable results, you should leave the instrument turned on and the probe connected for at least 15 minutes prior to a calibration.
- You should also perform the calibration in the environment where the conductivity measurements will be taken (constant temperature and environmental conditions). Any changes in temperature can have an adverse effect on the measurements.

1. Follow the instruction as prompted on the display:
 - ◆ Place the probe on the lowest IACS percentage standard without a shim. Set the conductivity value for calibration point 1 (**COND1**) by rotating the knob to the value of the certified standard, and then selecting **STORE1** (E key).
COND 2 (B key) is then highlighted on the display.
2. Place the probe on the highest IACS percentage standard without a shim. Set the conductivity value for calibration point 2 (**COND2**) by rotating the knob to the value of the certified standard, and then selecting **STORE2** (E key).
COATING (C key) is then highlighted on the display (see Figure 5-50 on page 162).
3. Place the probe on the lowest IACS percentage standard with the 4 mil shim, and then select **STORE3** (E key).

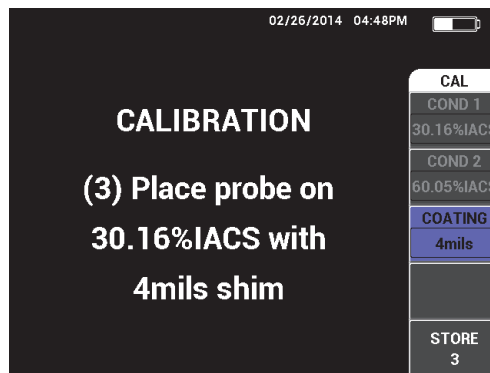

Figure 5-50 The displayed instruction (3)

COATING (C key) is then highlighted on the display (see Figure 5-51 on page 163).

- Place the probe on the highest IACS percentage standard with the 4 mil shim, and then select **STORE4** (E key).

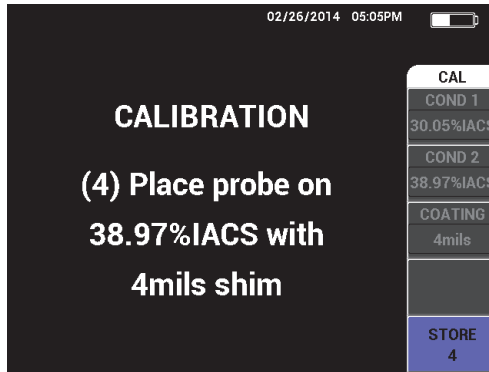

Figure 5-51 The displayed instruction (4)

- Complete the calibration by selecting **DONE** after **Success** is displayed (see Figure 5-52 on page 163).

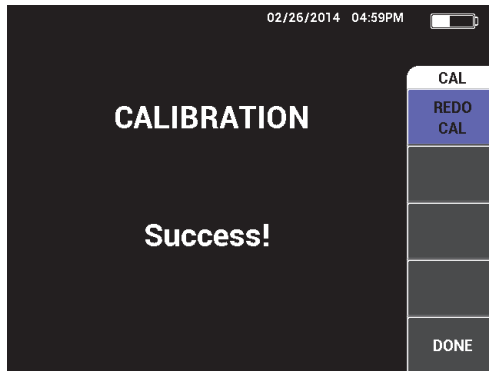

Figure 5-52 The confirmation of a completed calibration

6. Use the NORTEC 600 instrument and probe to measure the conductivity of the test material and the thickness of the nonconductive paint layer on the test material.

Conductivity measurement screen

After a successful calibration, the conductivity measurement screen is displayed. This screen displays the conductivity and coating thickness values. A bar graph shows the current measurement value (between the minimum and maximum values), and arrows indicate the minimum and maximum alarm thresholds (if enabled).

NOTE

Conductivity measurements continue until the conductivity probe is disconnected, which closes the measurement window. If the instrument senses that there is no longer a conductive surface under the conductivity probe, the conductivity and coating thickness readings on the screen are refreshed (renewed).

Conductivity mode with impedance plane

While in conductivity/coating thickness mode, the NORTEC 600 can display an impedance plane. To activate this view, press and hold the MAIN FILTER menu key () , and then press the GAIN key (**dB**). However, the functionalities of this special function have yet to be tested, so it should only be used for research purposes and none of the parameters should be changed.

To save measurements

- ◆ Save your conductivity and coating thickness measurements at any time by pressing the REF SAVE key (). Saved measurements can be reviewed later in the datalogger or in the memory screen.

To set alarms for conductivity and coating thickness

High and low threshold alarm settings are available for conductivity and coating thickness measurements. Alarms can be set as positive or negative and with or without an audible alarm sound.

NOTE

The instrument's conductivity and coating thickness mode must be activated in order to access the alarm setups described in this section.

1. Press the ALARM menu key (.
2. Press the A key, and then rotate the knob to set the desired **COND LO** (conductivity low) value.
3. Press the B key, and then rotate the knob to the desired **COND HI** (conductivity high) value.
4. Press the C key, and then set the polarity of the alarm:
 - ◆ Choose **POSITIVE** to enable an alarm when the conductivity is between the low and high value.
 - OR
 - Choose **NEGATIVE** to enable an alarm when the conductivity is outside the low or high value.
5. Press the E key to enable the audible alarm (**HORN**), and then rotate the knob to the **OFF**, **LOW**, or **HIGH** setting.

To set the coating thickness alarm

1. Press the ALARM menu key () twice (or, if you have just set up the conductivity alarm, press only once).
2. Press the A key, and then rotate the knob to the desired **THCK LO** (low thickness) value.
3. Press the B key, and then rotate the knob to the desired **THCK HI** (high thickness) value.
4. Press the C key, and then set the polarity of the alarm:
 - ◆ Choose **POSITIVE** to enable an alarm when the coating thickness is between the low and high value.
 - OR
 - Choose **NEGATIVE** to enable an alarm when the coating thickness is outside the low or high value.
5. Press the E key to enable the audible alarm (**HORN**), and then rotate the knob to the **OFF**, **LOW**, or **HIGH** setting.

5.1.7 Inspecting Aircraft Wheels — All NORTEC 600 Models

This section contains an example procedure for inspecting aluminum aircraft wheels. Inspection materials are shown in Figure 5-53 on page 166.



Figure 5-53 Materials—aircraft wheels

The following products are used in this procedure:



- Special-purpose aircraft wheel inspection probe; P/N: WP-3-1537-L
- Cable: 1.83 m (6 ft) length, bridge coil configuration, 16 pin LEMO to Fischer/LEMO triaxial (SPO-6472). P/N: 9122244 [U8800091]
- Special-purpose aircraft wheel inspection standard; P/N: WS-3-1537

NOTE

Any wheel probe with matching standard can be used for this application.

To set the initial NORTEC 600 configuration

1. Connect the probe and the cable to the PROBE connector on the NORTEC 600.

- Press the ADV SETUP menu key () once, and then select **APPL SELECT** (A key) to open the application selection menu. Select **Surface Cracks** with the knob, and then press  to accept (see Figure 5-54 on page 167).

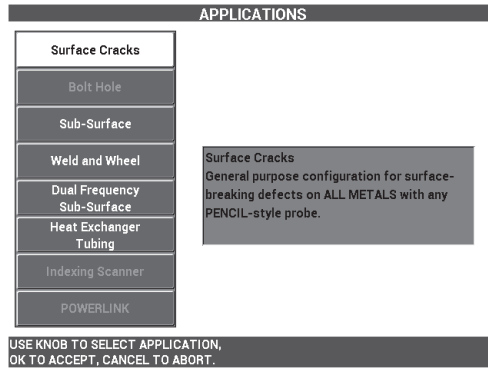



Figure 5-54 The Surface Cracks application

To calibrate the signals

- Press the MAIN FILTER menu key (), and set the **FREQ** (A key) to **200 kHz** using the knob.
- Place the probe at the approximate midpoint on the standard (between two notches), and then, while firmly pressing the probe on the standard, press the **A-LIFT NULL** key ().
- Scan the standard using a back-and-forth motion, press the **GAIN** key (**dB**), and then adjust the signal amplitude (with the knob) until the signals extend across approximately 80 % of the screen width (see Figure 5-55 on page 168).

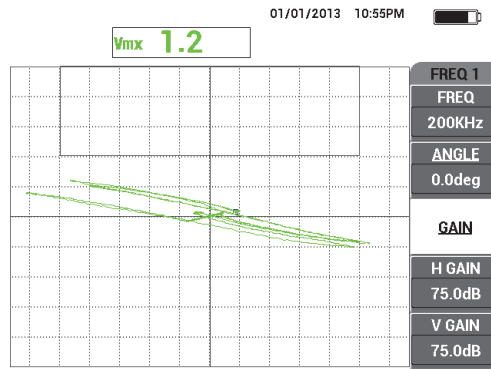



Figure 5-55 The signals extending across the screen

4. When the signals extend across 80 % of the screen width, press the ERASE key ().
5. Scan the center notch only, and then press the FREEZE key () [see Figure 5-56 on page 168].

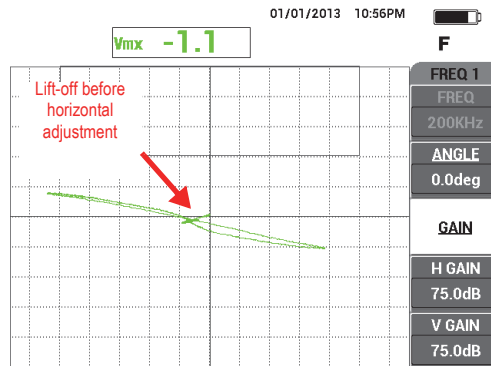



Figure 5-56 Scanning the center notch

6. Press the ANGLE key () , and then adjust the signal angle with the knob so that the lift-off (probe motion) signal is as horizontal as possible (see Figure 5-57 on page 169).

To achieve an adequate fine ANGLE adjustment, it may be necessary to switch to the fine-adjustment mode by pressing the Enter key (✓) while adjusting the ANGLE.

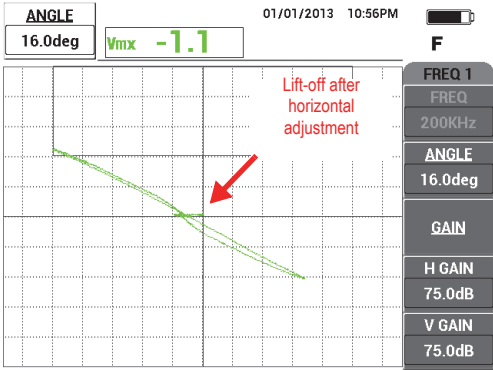

Figure 5-57 Setting the signal as close as possible to horizontal

- 7. Press the GAIN key (**dB**) 3 times to access the V GAIN parameter, and then increase the vertical gain with the knob until the signals reach about 80 % of the screen height (see Figure 5-58 on page 169).

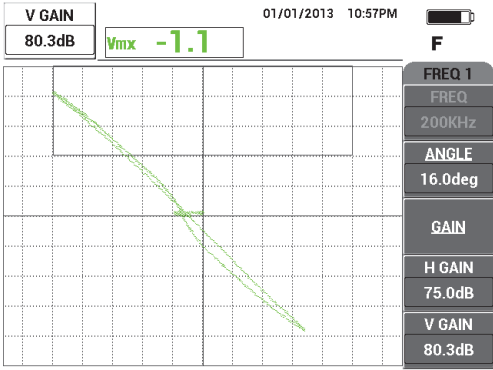

Figure 5-58 The signals extending vertically across the screen

8. Press the FREEZE key (❄️) to unfreeze the acquisition, place the probe between two notches on the standard, press the A-LIFT NULL key (⊕^{A-LIFT}), and then scan the standard.

The resulting signal should resemble the example shown in Figure 5-59 on page 170. If necessary, freeze the signal again and fine-tune the vertical gain or angle.

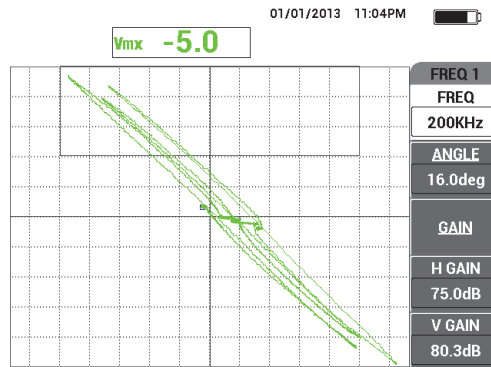

Figure 5-59 The results after scanning the standard

To fine-tune the instrument settings

1. Depending on your requirements, set the alarm parameters, horn, or external horn (louder). For more details about alarms, see “Alarm Menus” on page 298. The alarm parameters shown Figure 5-60 on page 171 in can be used as **NEGATIVE** Box alarm.

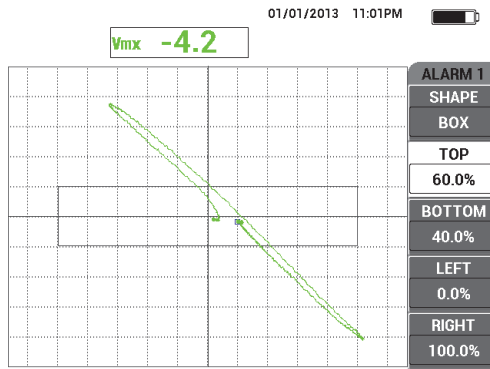

Figure 5-60 The Alarm parameters

2. Depending on your requirements, set the display erase or persistence values to automatically refresh the screen.

For more details about screen erase options, see “D ERASE (display erase)” on page 95 and “PERSIST (variable persistence)” on page 95.

3. Press the FULL NEXT key () to toggle to the full-screen mode, and then scan the standard.

The resulting signal should resemble the example shown in Figure 5-61 on page 172. Note that the value of the maximum signal amplitude and the signal angle are displayed by default. For more details about the reading type or position in the impedance plane display, see “Displaying Real-Time Readings” on page 62.

The list of all parameters is shown in Figure 5-62 on page 172.

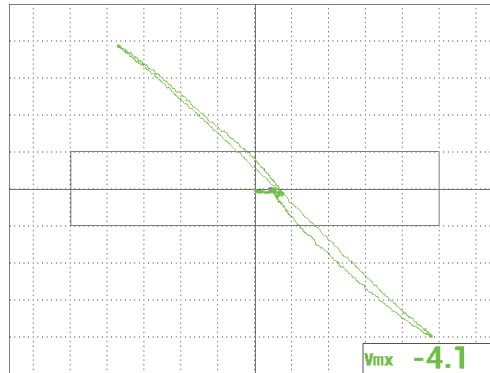

Figure 5-61 The signal after fine tuning

SINGLE FREQUENCY			
FREQ MODE	SINGLE	FREQ	200KHz
ID	No Probe	ANGLE	16.0deg
SERIAL #	No Probe	H GAIN	75.0dB
PRB CONN	LEMO-16	V GAIN	80.3dB
PRB DRV	MEDIUM	H POS	50%
HI PASS	OFF	V POS	50%
LO PASS	500Hz	SHAPE 2	SECTOR
CONT NUL	OFF	OUTR DIA	90%
DSP MODE	IMP	INNDR DIA	35%
GRID	FINE	STRTR ANG	10deg
PERSIST	OFF	END ANG	130deg
D ERASE	OFF	SHAPE 3	SWEEP
SWP ERS	ON	TOP	70.0%
SWP MODE	AUTO Y	BOTTOM	30.0%
SWP TIME	0.300sec	W START	1
SYNC ANG	0deg	W END	32
SCAN RPM	ORPM	W ERASE	MANUAL
		W CURSOR	1

SINGLE FREQUENCY			
ALARM 1	FRQ1 NEG	RDG1 TYP	VMAX
ALARM 2	OFF	RDG1 LOC	BOT RIGHT
ALARM 3	FRQ1 NEG	RDG2 TYP	OFF
		RDG2 LOC	TOP RIGHT
		TIME WIN	0.5sec
HORN	OFF	CAP MODE	INSTANT
DWELL	0.0sec	CAP DLY	5.0sec
EXT HORN	ON	AOUT PWR	OFF

PRESS [A] FOR FIRST COL., [B] FOR SECOND COL., [C] FOR THIRD COL., [E] FOR NEXT.

PRESS [A] FOR FIRST COL., [B] FOR SECOND COL., [E] FOR PREV.

Figure 5-62 The list of all parameters



5.1.8 Inspecting Critical Fastener Holes with a Controlled Translation (Indexing) Scanner — NORTEC 600S and NORTEC 600D Models

This section contains a procedure for inspecting critical fastener holes using Evident indexing rotating scanner model PS5-AL. The NORTEC 600 includes a very useful waterfall cursor function, which enables you to easily estimate the location of defects in aircraft skin assemblies.

The following products are used in this procedure:

- PS5-AL indexing scanner (product discontinued)
- Reflection probe for PS5: 200 kHz to 1 MHz, RD 0.250 (reflection differential 6.4 mm [0.25 in.]); P/N: 9217572 [U8616045]
- Eddy current hole standard for demonstration purposes (not certified); P/N: RSTD-10135 [U8863213]

To set the initial NORTEC 600 configuration

1. Connect the probe to the rotating scanner (align the connector marks), and then connect the scanner cable to both the rotating scanner and the PROBE connector on the NORTEC 600.
2. When prompted, select **CONTINUE** (A key) to accept the PowerLink information.
3. Press the ADV SETUP menu key () once, and then select **APPL SELECT** (A key) to open the application selection menu. Select **Indexing Scanner** with the knob, then press  to accept (see Figure 5-63 on page 173).

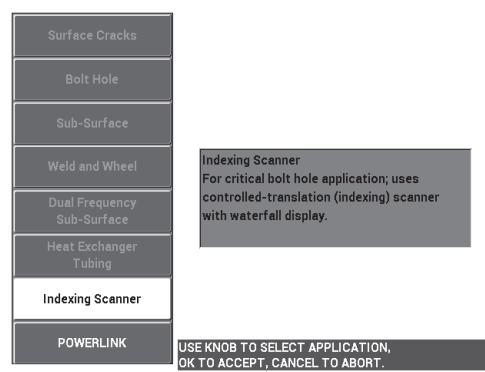





Figure 5-63 The Indexing Scanner application

To calibrate the signals

1. Adjust the probe's Z position (for indexing) so that it extends halfway down into the calibration hole.
For more information on operating the PS5 indexing scanner, refer to the scanner's *User's Manual*.

2. Ensure that the scanner motor is turned off before initial instrument nulling, place the probe in the good hole, and then press the A-LIFT NULL key ().
3. Place the probe in the hole with EDM notches, and then adjust the index axis so that the probe rotates freely next to a defect area.
Leave the scanner in the R position (rotation).
4. Turn on the scanner motor, and then press the MAIN FILTER menu key () twice, and set the **SCAN RPM** (E key) to **240**.
5. Press the MAIN FILTER menu key (), and then change the **FILT TYP** (C key) to **FIG 6** (see Figure 5-64 on page 174).

NOTE

This procedure uses the Figure 6 filter setting. Evident recommends using the Figure 6 filter setting unless an absolute probe is being used, in which case the Figure 8 filter setting might provide better performance. For more information about the Figure 6 versus Figure 8 parameters, see “Inspecting Fastener Holes with a Rotating Scanner — NORTEC 600S and NORTEC 600D Models” on page 132.

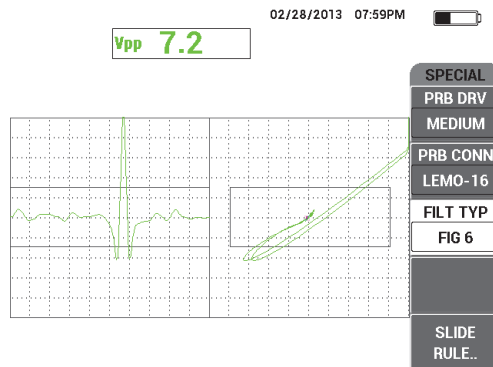



Figure 5-64 The Figure 6 filter

6. Press the ANGLE key () , and then adjust the lift-off (probe-motion) angle so that it is as horizontal as possible and the notch signal points upward (see Figure 5-65 on page 175).

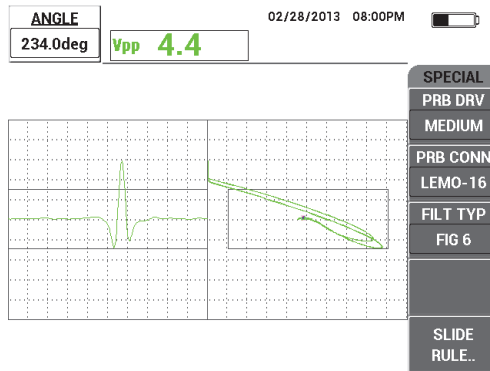

Figure 5-65 Adjusting the signal angle

7. Press the GAIN key (**dB**), and then decrease the horizontal gain until the notch signal is contained within the first horizontal division (10 % horizontal) [see Figure 5-66 on page 175].

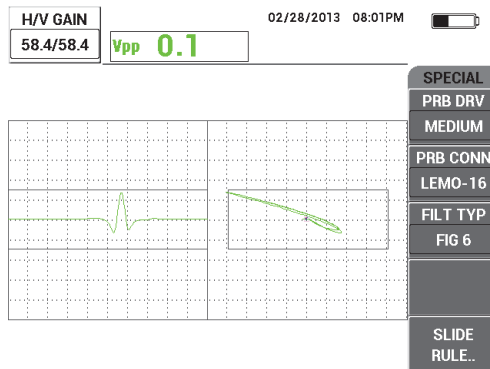

Figure 5-66 Adjusting the gain

8. Press the GAIN key (**dB**) twice, and then increase the **V GAIN** until the notch signal reaches full screen height (100 % vertical) [see Figure 5-67 on page 176].

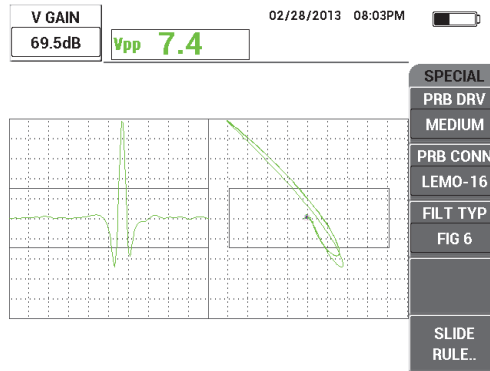



Figure 5-67 Adjusting the vertical gain

9. Press the DISP menu key () , and then set the **SYNC ANG** (D key) to center the notch signal on the strip chart (see Figure 5-68 on page 176).

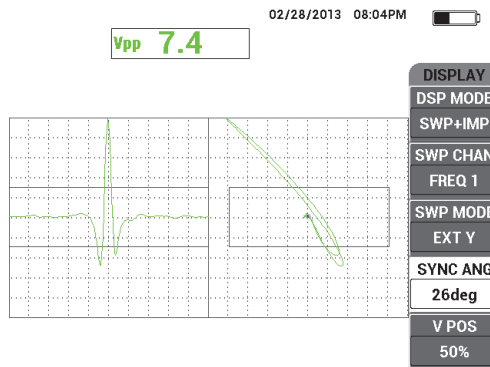

Figure 5-68 Adjusting the sync angle

10. Set the **DSP MODE** (A key) to **WATERFALL**.
11. Validate that the PS5 scanner is ready to perform a scan.

The waterfall parameters should not be changed until the PS5 scanner is properly adjusted following a scan.

12. Set the scanner to the T position (for testing), and then scan the entire hole.
13. Adjust both limit switches so that the probe fully scans the hole and then exits freely into the air.

To maintain efficient inspection productivity, try to minimize the “air travel” time outside the hole.

After the PS5 scanner is operating satisfactorily, you will be able to set the waterfall parameters for a full waterfall display of the inspected hole.

The best results are obtained when the **W END** (D key) parameter is set to cover an entire scanning motion.

14. Adjust the **W END** parameter to cover an entire scanning motion:
 - a) With the probe positioned at either end of the hole, press the E button on the PS5 scanner, and then press the motor switch and scan the entire hole.

Closely observe the waterfall display and, if necessary, increase the **W END** value (D key) if the waterfall display has been cut off, erased, or refreshed before the scan is terminated.
 - b) When the probe reaches the other end of the hole, press the E key on the scanner, and then scan the entire hole again.

Closely observe the waterfall display to check if a cut-off or incomplete scan display occurs. If so, decrease the **W END** value (D key).
 - c) Repeat steps a–b until you find the right balance between two successive, complete scans (in both directions) to fully produce two waterfall displays.
15. When the waterfall display is correct, set the **W CURSOR** (E key) [waterfall cursor] to the estimated location of the boundary between two critical layers, and adjust the **W CURSOR** while you continue complete scanning motions (see Figure 5-69 on page 178).

After it is properly adjusted, the waterfall cursor is very useful in helping locate a defect’s position both above and below the critical layer, and it can be used to decide if a flaw should be accepted or rejected.



02/28/2013 08:22PM 

Figure 5-69 Using the waterfall cursor

16. Press the FULL NEXT key () to toggle to the full-screen mode, and then scan the standard.

The scan result should resemble the example image shown in Figure 5-70 on page 178.

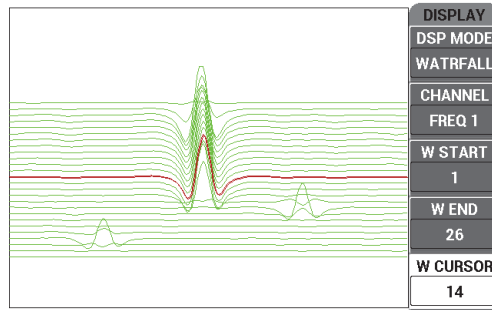
The list of all parameters is shown in Figure 5-71 on page 179.

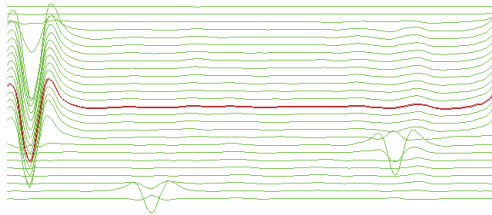

Figure 5-70 The scan result

SINGLE FREQUENCY			
FRQ MODE	SINGLE	FREQ	200KHz
ID	PS5-AL2000	ANGLE	234.0deg
SERIAL.#	504	H GAIN	58.4dB
PRB CONN	LEMO-16	V GAIN	69.5dB
PRB DRV	MEDIUM		
HI PASS	16Hz		
LO PASS	80Hz	H POS	50%
CONT NUL	OFF	V POS	50%
DSP MODE	WATRFALL		
GRID	OFF		
PERSIST	OFF		
D ERASE	0.5sec		
SWP ERS	ON		
SWP MODE	EXT Y	W START	1
SWP TIME	0.010sec	W END	26
SYNC ANG	26deg	W ERASE	MANUAL
SCAN RPM	240RPM	W CURSOR	14
		SHAPE 1	BOX
		TOP	65.0%
		BOTTOM	35.0%
		LEFT	10.0%
		RIGHT	90.0%
		SHAPE 2	SWEEP
		TOP	65.0%
		BOTTOM	35.0%
		SHAPE 3	POLAR
		RADIUS	25.0%
		HORZ	50.0%
		VERT	50.0%

SINGLE FREQUENCY			
ALARM 1	FRQ1 NEG	RDG1 TYP	VPP
ALARM 2	FRQ1 NEG	RDG1 LOC	TOP CNTR
ALARM 3	OFF	RDG2 TYP	OFF
		RDG2 LOC	TOP RIGHT
		TIME WIN	0.5sec
HORN	OFF	CAP MODE	INSTANT
DWELL	0.0sec	CAP DLY	5.0sec
EXT HORN	ON	AOUT PWR	OFF

PRESS [A] FOR FIRST COL, [B] FOR SECOND COL, [C] FOR THIRD COL, [E] FOR NEXT. PRESS [A] FOR FIRST COL, [B] FOR SECOND COL, [E] FOR PREV.

Figure 5-71 The list of all parameters

5.2 Special and Educational Applications

This section provides basic setting recommendations for older eddy current procedures that are still used in eddy current training classes. These training procedures are useful in explaining the effect that various parameters have on eddy currents, parameters such as lift-off, resistivity, frequency, magnetic permeability, thickness, and discontinuities.

The four applications included in this section all use the following equipment (see Figure 5-72 on page 180):





Figure 5-72 Materials—special and educational applications

- Surface probe: reflection detachable surface probe with a diameter of 11.2 mm (0.44 in.) and an operating range of 500 Hz to 60 kHz (equivalent to APBK/10.5/S, SPO-2025), triaxial Fischer/LEMO connector; P/N: 9213552 SR/500Hz-60KHZ-/.44 [U8623007]
- SPO-6687 cable for reflection coil configuration probes with triaxial Fischer/LEMO connector to NORTEC 500, 600, 1000, or 2000 series instrument (16 pin LEMO), 1.83 m (6 ft.) length; P/N: SPO-6687 [U8800538]
- General purpose demonstration and training standard; P/N: NEC-6151-SD [U8861706]

5.2.1 Using the Impedance Plane Theory and Display — All NORTEC 600 Models

This application is usually one of the first topics used to explain basic eddy current theory in eddy current training classes.

To use the impedance plane theory and display

1. Connect the probe and the cable to the PROBE connector on the NORTEC 600.
2. Press the ADV SETUP menu key () once, and then select **APPL SELECT** (A key) to open the application selection menu. Select **Surface Cracks** with the knob, then press  to accept (see Figure 5-73 on page 181).

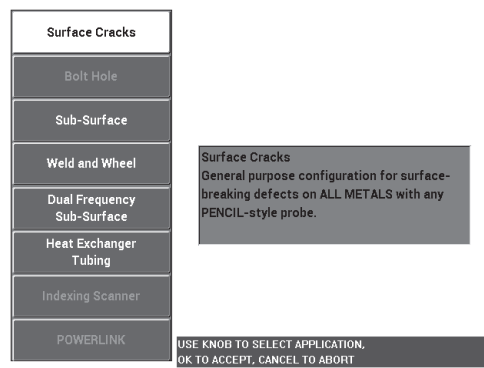







Figure 5-73 The Surface Cracks application

3. Press the DISP menu key (), and set the **POSITION** (C key) to **TOP CNTR**.
4. Press the DISP menu key () again, and set the **GRID** (D key) to **OFF**.
5. Press the ALARM menu key (), and set the **ALARM 1** (A key) to **OFF**.
6. Press the MAIN FILTER menu key (), and set the **FREQ** (A key) to **60 kHz**.
7. Set the **GAIN** (C key) to approximately 40 dB.
8. Hold the probe in the air, and then press the A-LIFT NULL key ().
9. Gently touch the ferrite sample with the probe, and continue to repeatedly gently tap the sample (see Figure 5-74 on page 182). While tapping, press the ANGLE key () and adjust the ferrite signal angle until it is oriented straight upward (90°) [see Figure 5-75 on page 182].

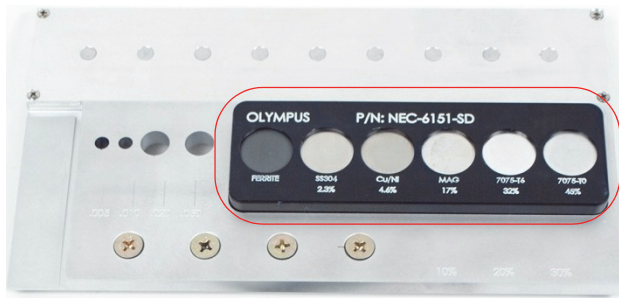

Figure 5-74 The section of the standard used for impedance plane theory

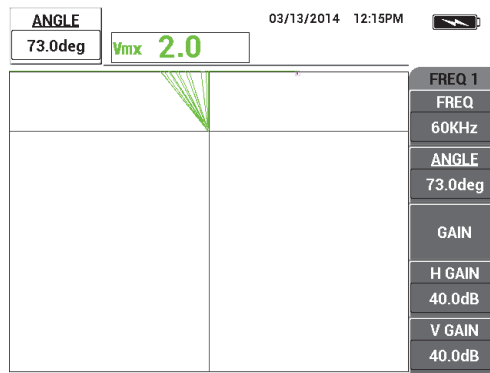

Figure 5-75 Adjusting the signal angle to 90°

10. Place the probe on the 45 % conductivity sample, and then press the GAIN key (**dB**) and decrease the gain until the live dot is within screen area (see Figure 5-76 on page 183).

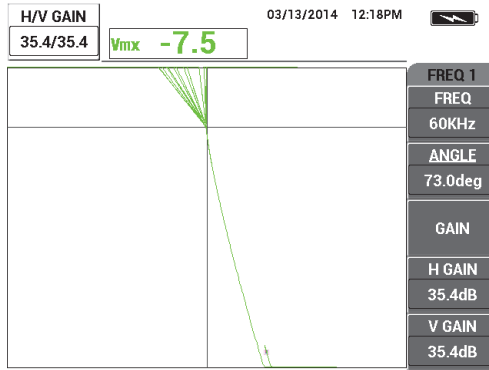

Figure 5-76 Adjusting the gain

11. Press the FULL NEXT key (➡) to toggle to full-screen mode, then successively place the probe on each sample to display the effect of conductivity and magnetic permeability on the impedance plane (see Figure 5-77 on page 183).

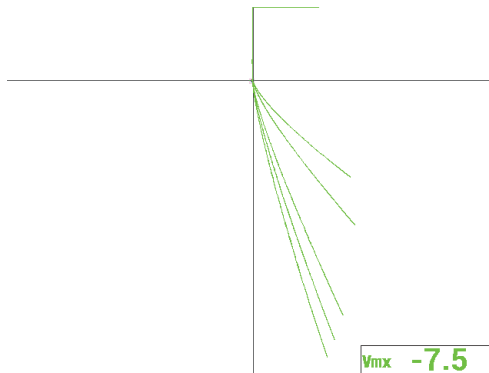



Figure 5-77 Displaying the effect of conductivity and magnetic permeability

5.2.2 Sorting Metals by Evaluating Conductivity — All NORTEC 600 Models

This application shows how to sort metals by using differences in conductivity and resistivity, which can be viewed on the impedance plane display. This method is only valid for non-ferromagnetic metals.

To sort metals by evaluating conductivity

1. Connect the probe and the cable to the PROBE connector on the NORTEC 600.
2. Press the ADV SETUP menu key () once, and then select **APPL SELECT** (A key) to open the application selection menu. Select **Surface Cracks** with the knob, then press  to accept (see Figure 5-78 on page 184).

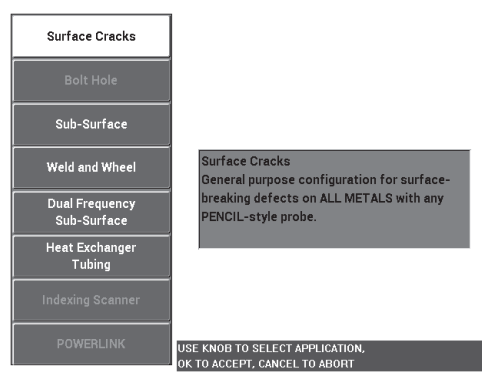





Figure 5-78 The Surface Cracks application

3. Press the DISP menu key (), and set the **POSITION** (C key) to **BOT RIGHT**.
4. Press the MAIN FILTER menu key (), and set the **FREQ** (A key) to 60 kHz.
5. Set the **GAIN** (C key) to approximately 50 dB.
6. Place the probe on the 45 % conductivity sample (see Figure 5-79 on page 185), and then press and hold the A-LIFT NULL key () to activate the automatic liftoff function.

After a brief moment, the NORTEC 600 beeps and displays **LIFT PROBE** at the top of the screen. When this text is displayed, lift the probe into the air, and wait for the message to disappear.

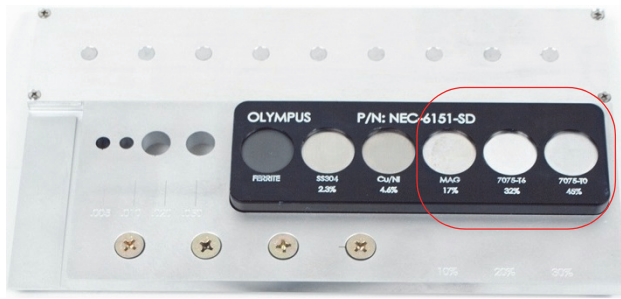

Figure 5-79 The section of the standard used for conductivity evaluation

7. Repeat step 6 until you become familiar with the automatic liftoff function. It may take some practice to obtain the proper timing with the automatic lift-off function, but once mastered, this function will help you obtain a faster calibration.
8. Place the probe successively on the 17 %, 32 % and, 45 % conductivity samples, and then press the FREEZE key (❄️) when done (see Figure 5-80 on page 185).

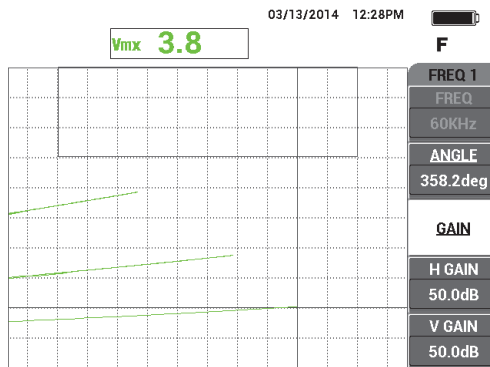

Figure 5-80 The signals from different conductivity samples

9. Press the ANGLE key (◁), and then adjust the lower signal (45 % conductivity) so that it is horizontal (see Figure 5-81 on page 186).

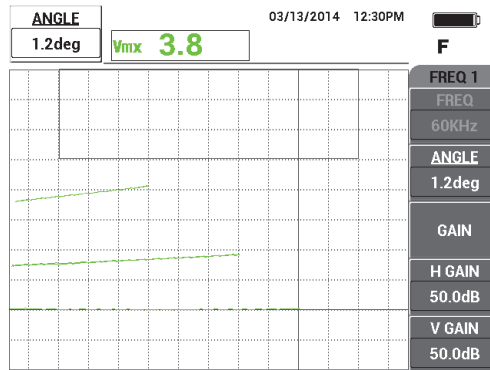

Figure 5-81 Adjusting the lower signal to horizontal

- Press the GAIN key (**dB**) 3 times to access the **V GAIN** parameter, and increase the vertical gain until the upper signal reaches 90 % of the screen height (see Figure 5-82 on page 186).

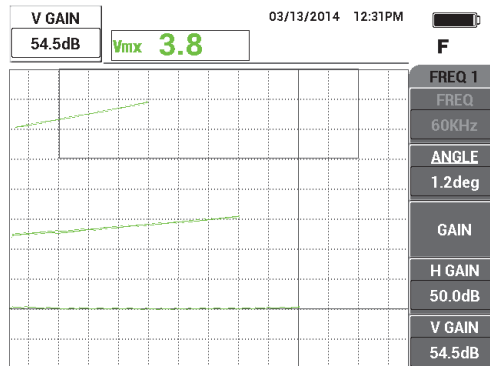



Figure 5-82 Adjusting the vertical gain

- Press the ALARM menu key () twice, and then set the **TOP** (B key) to 65 %, the **BOTTOM** (C key) to 35 %, and the **LEFT** (D key) to 30 %.
- Press the ALARM menu key () twice again, and then set the **HORN** (E key) to **ON**.

13. Press the FREEZE key (❄️) to unfreeze the acquisition, and then press the FULL NEXT key (🖥️➡️) to toggle to full-screen mode.
14. Place the probe on the different conductivity samples, and evaluate the vertical positions of the signals to decide whether to accept or reject the sample (see Figure 5-83 on page 187). The vertical position, or height, of the signal's end point represents the conductivity value that is used for acceptance or rejection, and the horizontal position represents the lift-off.

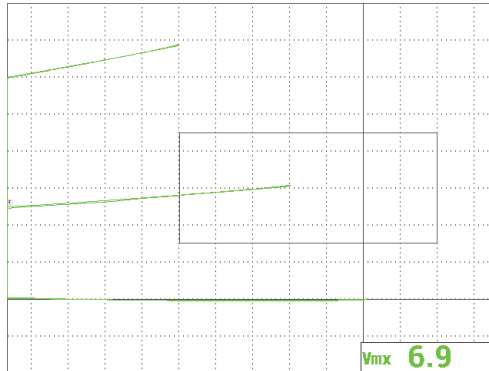

Figure 5-83 Using the vertical position of the signal to accept or reject the sample

5.2.3 Evaluating Nonconductive Coating (Paint) Thickness — All NORTEC 600 Models

This section contains a simple, older procedure for evaluating coating (paint) thickness based on lift-off signal.

To evaluate nonconductive coating thickness

1. Connect the probe and the cable to the PROBE connector on the NORTEC 600.
2. Press the ADV SETUP menu key (📄⚙️) once, and then select **APPL SELECT** (A key) to open the application selection menu. Select **Surface Cracks** with the knob, then press ✓ to accept (see Figure 5-84 on page 188).

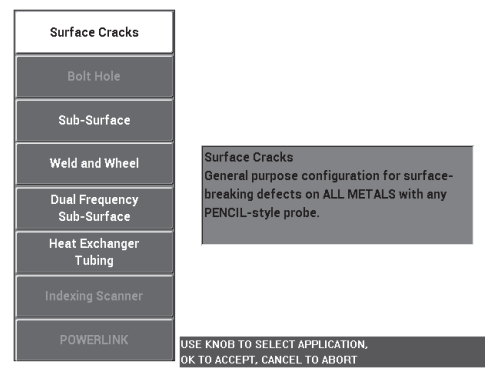

Figure 5-84 The Surface Cracks application

3. Press the DISP menu key (□), and set the **POSITION** (C key) to **BOT CNTR**.
4. Press the MAIN FILTER menu key (✂), and set the **FREQ** (A key) to 60 kHz.
5. Set the **GAIN** (C key) to approximately 50 dB.
6. Turn the standard upside down (to expose the larger face; see Figure 5-85 on page 188), place the probe on an area that is free of defects, and then press the A-LIFT NULL key (⊕^{A-LIFT}).

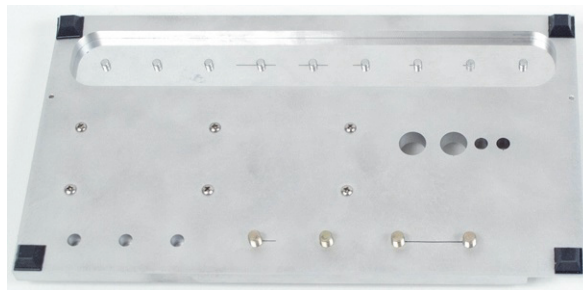

Figure 5-85 The back of the standard

7. Lift the probe away from the surface, and then bring the probe down and touch the sample again; while repeating these motions, press the **ANGLE** key (◁_θ).

and adjust the lift-off angle until it is oriented straight upward (90°) [see Figure 5-84 on page 188].

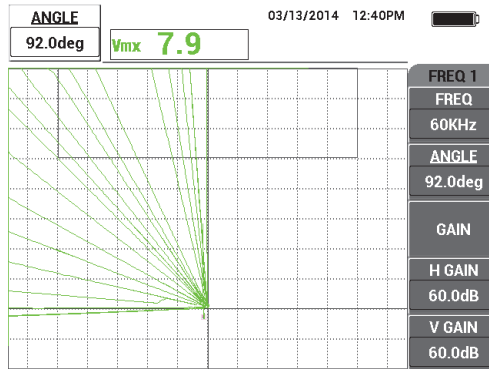



Figure 5-86 Adjusting the lift-off angle to 90°

8. Press the ERASE key () , place the probe on the sample again (this time use a larger lift-off or paint thickness value; for example, the thickness of three business cards), and then press the GAIN key (**dB**), and decrease the gain until the live dot is within the screen area and is at about 90 % of the screen height (see Figure 5-87 on page 189).

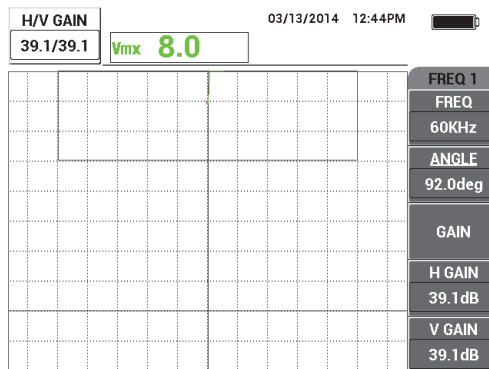



Figure 5-87 Adjusting the gain

9. Press the DISP menu key (), and then, while holding the probe on the three business cards, adjust the H POS (D key) to 0 %, then up to 100 %, and back down to 50 %.

A horizontal mark is created (see Figure 5-88 on page 190).



Figure 5-88 Using H POS to create a horizontal mark

10. Repeat step 9 using two business cards, and then again using one business card to create more horizontal marks (see Figure 5-89 on page 190).

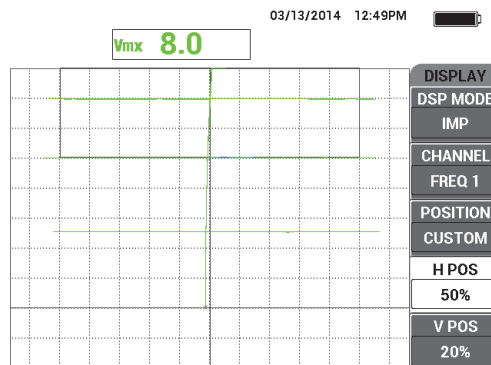



Figure 5-89 Creating more horizontal marks

- 11. Press and hold the REF SAVE key (REF ) , and then press the ERASE key () to clear the live signals (see Figure 5-90 on page 191).

You can now evaluate unknown paint thicknesses using the vertical signal deflection, which represents the lift-off.

Alternatively, depending on your preferences, you can use the alarm to create a simple accept/reject test.

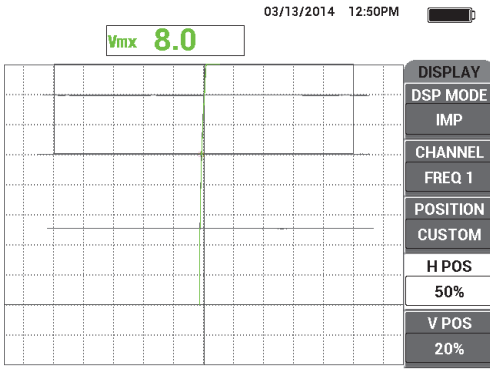



Figure 5-90 Using the vertical signal deflection to evaluate unknown thicknesses

5.2.4 Evaluating Metal Thickness and Using Thickness Curve Theory — All NORTEC 600 Models

This section outlines the typical thickness curve that is associated with phase lag and skin-depth eddy current theory.

To evaluate the metal thickness and use thickness curve theory

- 1. Connect the probe and the cable into the PROBE connector on the NORTEC 600.
- 2. Press the ADV SETUP menu key () once, and then select **APPL SELECT** (A key) to open the application selection menu. Select **Surface Cracks** with the knob, then press  to accept (see Figure 5-91 on page 192).

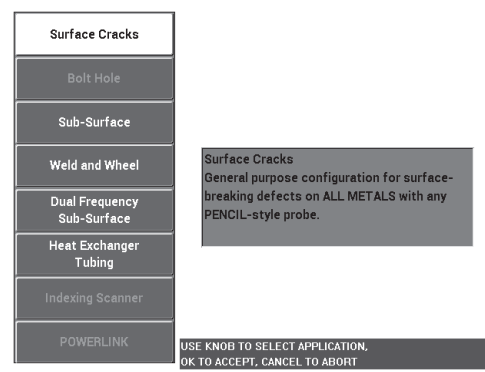







Figure 5-91 The Surface Cracks application

3. Press the DISP menu key (), and set the **POSITION** (C key) to **BOT RIGHT**.
4. Press the MAIN FILTER menu key (), and set the **FREQ** (A key) to 1.5 kHz. Alternatively, you can also experiment with other frequencies, such as 500 Hz, 1 kHz, 3 kHz, and 5 kHz.
5. Place the probe on the thickest part of the standard's tapered area (see Figure 5-92 on page 192), and then press and hold the A-LIFT NULL key () to activate the automatic lift-off function.

After a brief moment, the NORTEC 600 beeps and displays **LIFT PROBE** at the top of the screen. When this text is displayed, lift the probe into the air, and wait for the message to disappear.



Figure 5-92 The section of the standard used for metal thickness

- 6. Repeat step 5 until you become familiar with the automatic lift-off function. It may take some practice to obtain the proper timing with the automatic lift-off function, but once mastered, this function will help you obtain a faster calibration.
- 7. Press the ERASE key (), then slowly scan the tapered area, and then, after completing the scan, press the FREEZE key (). An example of the resulting scan is shown in Figure 5-93 on page 193.

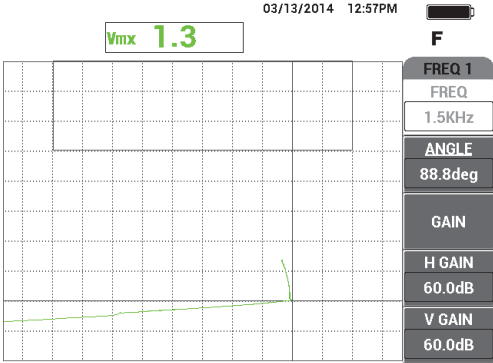



Figure 5-93 The scan of the tapered area

- 8. Press the ANGLE key (), and then adjust the lift-off angle so that it is horizontal (see Figure 5-94 on page 194).

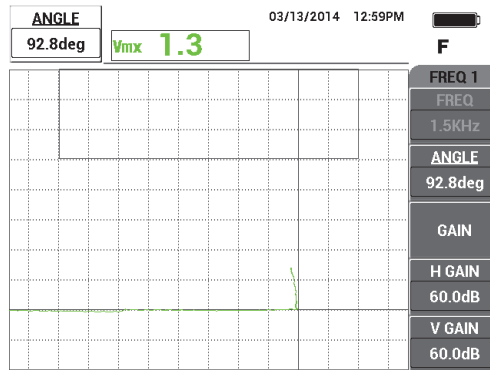

Figure 5-94 Adjusting the lift-off angle to horizontal

9. Press the GAIN key (**dB**), and then increase the gain until the signal extends across most of the screen (see Figure 5-96 on page 195).

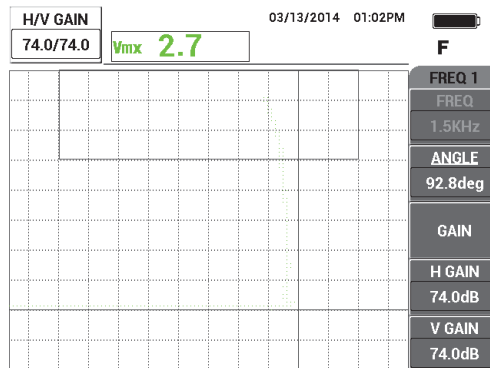

Figure 5-95 Adjusting the gain

10. Press the FREEZE key (❄️) to unfreeze the acquisition, and then press the FULL NEXT key (➡️) to toggle to full-screen mode.
11. Scan the standard's tapered area, and observe the thickness curve (see Figure 5-96 on page 195).

TIP

Use the **SET REF** function to record a background trace while another frequency is being tested.



Figure 5-96 The scan of the tapered part

5.3 Advanced Dual Frequency Applications

This section contains several procedures that provide advanced details on the dual-frequency function of the NORTEC 600.

NOTE

All procedures in this section are presented using the **OFFICE** color-scheme setting. This color scheme is used to help you follow the instructions, which feature up to three colored signal traces.

5.3.1 Detecting Corrosion Using Dual Frequency to Reduce the Pillowing Effect — NORTEC 600D Model

The procedure in this section uses dual frequency to help reduce the pillowing effect. This reduction facilitates the detection of subsurface corrosion in aircraft fuselages.

Inspection materials are shown in Figure 5-97 on page 196.





Figure 5-97 Materials—dual frequency for corrosion

The following products are used in this procedure:

- Surface probe: a standard reflection detachable surface probe with a diameter of - 11.2 mm (0.44 in.) and an operating range of 500 Hz to 60 kHz (equivalent to APBK/10.5/S, SPO-2025), triaxial Fischer/LEMO connector; P/N: 9213552 SR/500Hz-60KHZ-/.44 [U8623007]
- SPO-6687 cable for reflection coil configuration probes with triaxial Fischer/LEMO connector to NORTEC 500, 600, 1000, or 2000 series instrument (16 pin LEMO), 1.83 m (6 ft) length; P/N: SPO-6687 [U8800538]
- Special-purpose corrosion standard with pillowing inserts; P/N: RSTD-10145 [Q8600068]

To set the initial NORTEC 600 configuration

1. Connect the probe and the cable into the PROBE connector on the NORTEC 600.
2. Press the ADV SETUP menu key () once, and then select **APPL SELECT** (A key) to open the application selection menu. Select **Dual Frequency Sub-Surface** with the knob, then press  to accept (see Figure 5-98 on page 197).

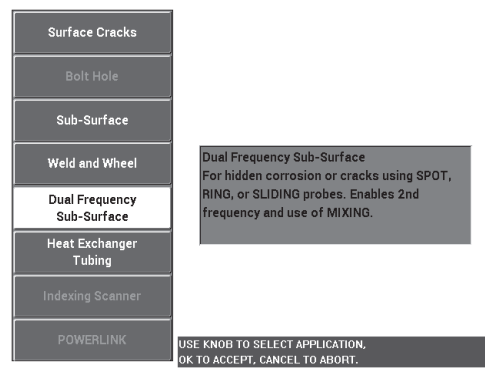









Figure 5-98 The Dual Frequency Sub-Surface application

3. Press the DISP menu key () twice, and then set the **POSITION** (C key) to **TOP LEFT** using the knob.
4. Press the DISP menu key () again, and then set the **POS 2** (C key) to **TOP LEFT** using the knob.
5. Press the DISP menu key () again, and then set the **MIX DISP** (A key) to **OFF** using the knob.
6. Press the MAIN FILTER menu key () four times, and then set the **LO PASS** (B key) to 50 Hz.
7. Press the MAIN FILTER menu key () again, and then set the **PRB DRV** (A key) to **HIGH**.
8. Press the ADV SETUP menu key (), select **ALL SETTINGS** (B key), press the E key, and then press the C key. Set the **RDG1 CHN** to **MIX**, then press the

FULL NEXT key () four times and set the **RDG2 TYP** to **OFF**. When done, press the Return key ().



The list of dual frequency parameters is shown in Figure 5-99 on page 198.

DUAL FREQUENCY					
SHAPE 1	BOX	ALARM 1	OFF	RDG1 CHN	MIX
TOP	100.0%	ALARM 2	OFF	RDG1 TYP	VMAX
BOTTOM	50.0%	ALARM 3	OFF	RDG1 LOC	BOT LEFT
LEFT	-10.0%			RDG2 CHN	FREQ 1
RIGHT	50.0%			RDG2 TYP	OFF
				RDG2 LOC	BOT RIGHT
				TIME WIN	0.5sec
SHAPE 2	BOX	HORN	OFF		
TOP	50.0%	DWELL	0.0sec		
BOTTOM	30.0%				
LEFT	55.0%	EXT HORN	ON	CAP MODE	INSTANT
RIGHT	110.0%			CAP DLY	5.0sec
SHAPE 3	BOX			AOUT PWR	OFF
TOP	100.0%				
BOTTOM	70.0%				
LEFT	55.0%				
RIGHT	110.0%				

PRESS [A] FOR FIRST COL., [B] FOR SECOND COL., [C] FOR THIRD COL., [E] FOR PREV.

Figure 5-99 The list of dual frequency parameters

To calibrate the signals

1. Press the MAIN FILTER menu key () once, and then set the **FREQ** (A key) value to 3.0 kHz using the knob.
2. Press the MAIN FILTER menu key () again, and then set the **FREQ 2** (A key) value to 1.0 kHz.
3. Place the probe on position 1 of the standard (see Figure 5-100 on page 199), and then, while firmly pressing the probe on the standard, press the A-LIFT NULL key ().

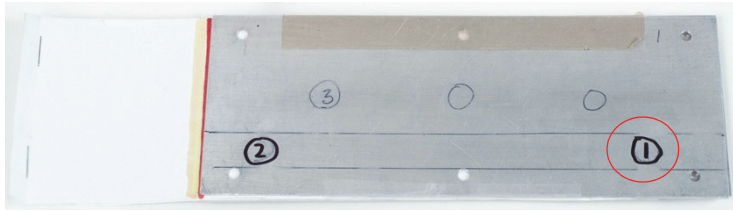



Figure 5-100 Position 1 of the standard

- Lift the probe into the air, then begin to gently tap the probe on position 1 of the standard, and, while tapping, press the ANGLE key () and then adjust the ANGLE (for frequency 1) until the lift-off signal is oriented towards the right side of the screen (the green signal in Figure 5-101 on page 199).

If necessary, you can press the ERASE key () to clear screen, which may make it easier to adjust the ANGLE value.

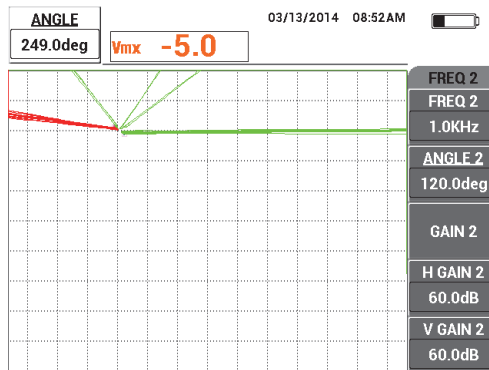



Figure 5-101 Adjusting the angle of the frequency 1 lift-off signal

- While continuing to gently tap the probe on position 1, press the ANGLE key () twice to open the ANGLE 2 parameter, and then adjust the angle of the frequency 2 lift-off signal until it also is oriented towards the right side of the screen, superposed on the frequency 1 signal (see Figure 5-102 on page 200).

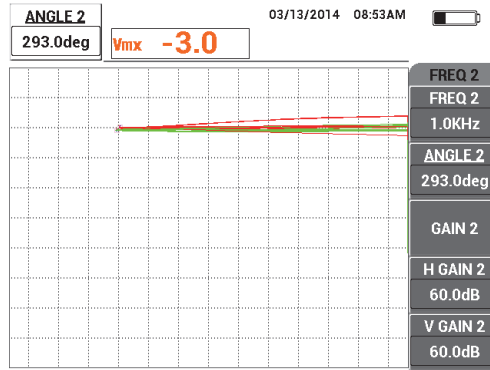

Figure 5-102 Adjusting the angle of the frequency 2 lift-off signal

6. Place the probe on position 1, and then press the A-LIFT NULL key (⊕).
7. Place the probe on position 2 (see Figure 5-103 on page 200), and then press the FREEZE key (❄).

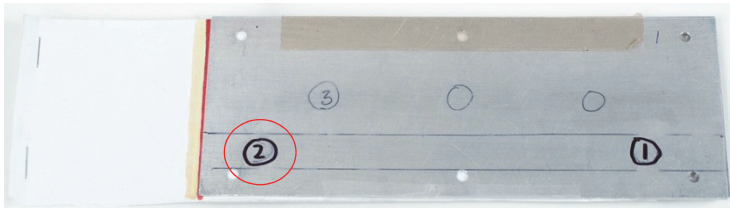

Figure 5-103 Position 2 on the standard

An example of the resulting frozen signals is shown in Figure 5-104 on page 201.

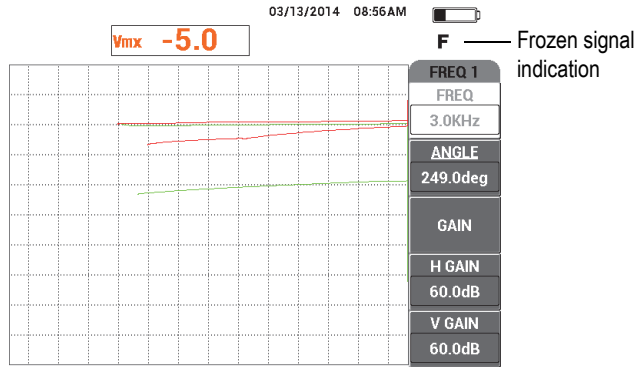

Figure 5-104 The frozen signals

8. Press the GAIN key (**dB**), and then increase the frequency 1 gain until the frequency 1 signal at position 2 is at 20 % of the screen height (see Figure 5-105 on page 201).

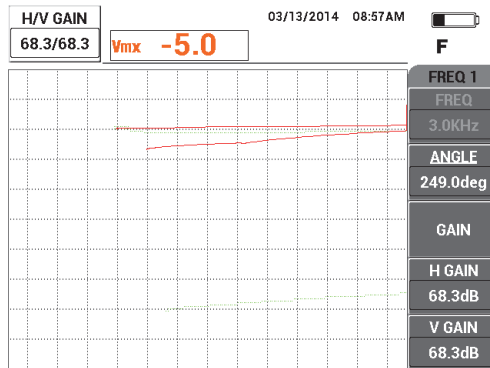

Figure 5-105 Adjusting the gain for frequency 1

9. Press the GAIN key (**dB**) three more times, and then increase the frequency 2 gain until the frequency 2 signal at position 2 is also at 20 % of the screen height (see Figure 5-106 on page 202).

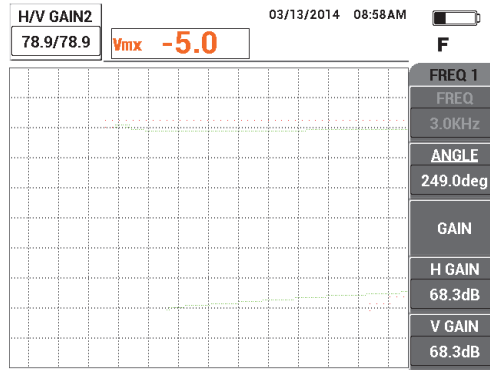

Figure 5-106 Adjusting the gain for frequency 2

10. Press the FREEZE key (✳) to unfreeze the acquisition.
11. Press the DISP menu key (□), and then set the **DSP MODE** (A key) to **IMP**, set the **CHANNEL** (B key) to **MIX**, and set the **POSITION** (C key) to **BOT RIGHT**.
12. Place the probe again on position 1, and then press the A-LIFT NULL key (⊕^{A-LIFT}).
13. Lift the probe into the air, press the MAIN FILTER menu key (✂), and then, while gently tapping the probe on position 1, decrease the **H GAIN** (D key) of frequency 1 until the lift-off signal of the **MIX** channel is oriented nearly horizontally (see Figure 5-107 on page 203).

If necessary, use the ERASE key (🗑) to clear the screen for easier adjustments.

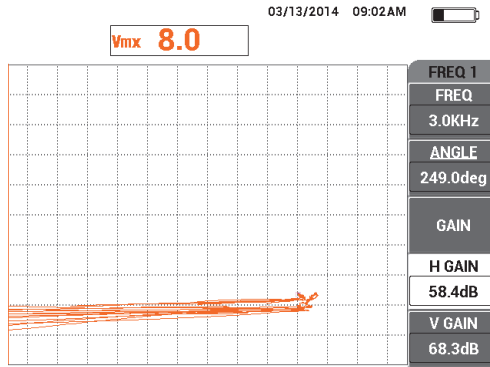

Figure 5-107 Adjusting the H GAIN for frequency 1

14. Place the probe on position 1 again, and then press the A-LIFT NULL key (\oplus).
15. While firmly pressing the probe at position 2 on the standard, observe the **MIX** signal point, and then press the MAIN FILTER menu key (\otimes) and decrease the **H GAIN 2** (D key) until the **MIX** signal operating point does not extend more than 3 divisions to the left of the null point (see Figure 5-108 on page 203).

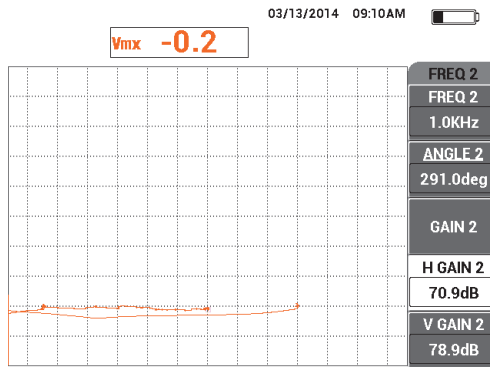

Figure 5-108 Adjusting the H GAIN 2 value

16. Place the probe on position 1 again, press the A-LIFT NULL key (A-LIFT \oplus), and then press the MAIN FILTER menu key (✂) repeatedly until the **FREQ 1** page is shown.
17. Tilt the probe at an arbitrary angle on position 1, observe the lift-off signal from the **MIX** channel, and then decrease the **H GAIN** (D key) until the lift-off signal from the **MIX** channel is oriented toward the left (see Figure 5-109 on page 204).

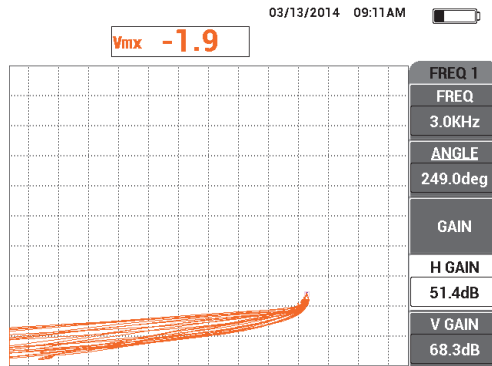

Figure 5-109 Adjusting the H GAIN value

18. Place the probe on position 1, and then press the A-LIFT NULL key (A-LIFT \oplus).
19. Scan the three corrosion defects, and then press the FREEZE key (❄).
20. Press the MAIN FILTER menu key (✂) twice, and then decrease the **H MIX GN** (C key) until the signal baseline fits between two horizontal divisions (see Figure 5-110 on page 205).

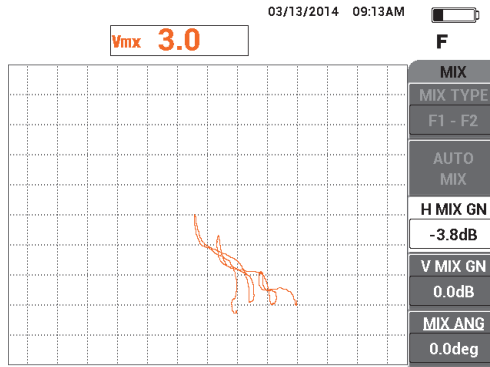

Figure 5-110 Adjusting the H MIX GN value

21. Increase the **V MIX GN** (D key) until the signal's maximum amplitude reaches 80 % of the screen height (see Figure 5-111 on page 205).

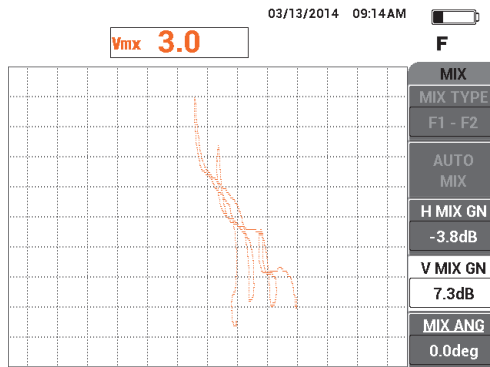

Figure 5-111 Adjusting the V MIX GN value

22. Press the FREEZE key (❄) to unfreeze the acquisition.
23. Press the FULL NEXT key (➡) to toggle to the full-screen mode.
24. Null the probe with the A-LIFT NULL key (⊕) on position 1, and then scan the three corrosion defects.

The resulting signals should resemble the example shown in Figure 5-112 on page 206.



Figure 5-112 The corrosion-defect scan result

To fine-tune the instrument settings

1. Depending on your requirements, set the alarm parameters, horn, or external horn (louder). For more details about alarms, see “Alarm Menu” on page 298.
2. Depending on your requirements, set the display erase or persistence values to automatically refresh the screen.

For more details about screen erase options, see “D ERASE (display erase)” on page 95 and “PERSIST (variable persistence)” on page 95.

The list of all parameters is shown in Figure 5-113 on page 207.

DUAL FREQUENCY			
FREQ MODE	DUAL	FREQ	3.0kHz
ID	No Probe	ANGLE	249.0deg
SERIAL #	No Probe	H GAIN	51.4dB
PRB CONN	LEMO-16	V GAIN	68.3dB
PRB DRV	HIGH	FREQ 2	1.0kHz
HI PASS	OFF	ANGLE 2	291.0deg
LO PASS	50Hz	H GAIN 2	70.9dB
CONT NUL	OFF	V GAIN 2	78.9dB
DSP MODE	IMP	SIG1 DSP	MIX
GRID	FINE	H POS	80%
PERSIST	OFF	V POS	20%
D ERASE	OFF	SIG2 DSP	IMP
SWP ERS	ON	H POS 2	20%
SWP MODE	AUTO Y	V POS 2	80%
SWP TIME	0.010sec	SIG3 DSP	OFF
SYNC ANG	0deg	H POS 3	80%
SCAN RPM	0RPM	V POS 3	50%
		MIX TYPE	F1 - F2
		H MIX GN	-3.8dB
		V MIX GN	7.3dB
		MIX ANG	0.0deg
		W START	1
		W END	32
		W ERASE	MANUAL
		W CURSOR	1

DUAL FREQUENCY			
SHAPE 1	BOX	ALARM 1	OFF
TOP	100.0%	ALARM 2	OFF
BOTTOM	50.0%	ALARM 3	OFF
LEFT	-10.0%		
RIGHT	50.0%		
SHAPE 2	BOX	HORN	OFF
TOP	50.0%	DWELL	0.0sec
BOTTOM	30.0%		
LEFT	55.0%	EXT HORN	ON
RIGHT	110.0%		
SHAPE 3	BOX		
TOP	100.0%		
BOTTOM	70.0%		
LEFT	55.0%		
RIGHT	110.0%		
		RDG1 CHN	MIX
		RDG1 TYP	VMAX
		RDG1 LOC	BOT LEFT
		RDG2 CHN	FREQ 1
		RDG2 TYP	OFF
		RDG2 LOC	BOT RIGHT
		TIME WIN	0.5sec
		CAP MODE	INSTANT
		CAP DLY	5.0sec
		ADUT PWR	OFF

PRESS [A] FOR FIRST COL. [B] FOR SECOND COL. [C] FOR THIRD COL. [E] FOR NEXT.

PRESS [A] FOR FIRST COL. [B] FOR SECOND COL. [C] FOR THIRD COL. [E] FOR PREV.

Figure 5-113 The list of all parameters

5.3.2 Detecting Sub-Surface Cracks Using Dual Frequency in a Lap Splice with Anodized and Alodine Rivets — NORTEC 600D Model

The procedure in this section uses the dual frequency and mix channel functions to help reduce undesirable signal variations caused by various fastener types during the detection of subsurface cracks in aircraft lap splices.

Inspection materials are shown in Figure 5-114 on page 208.

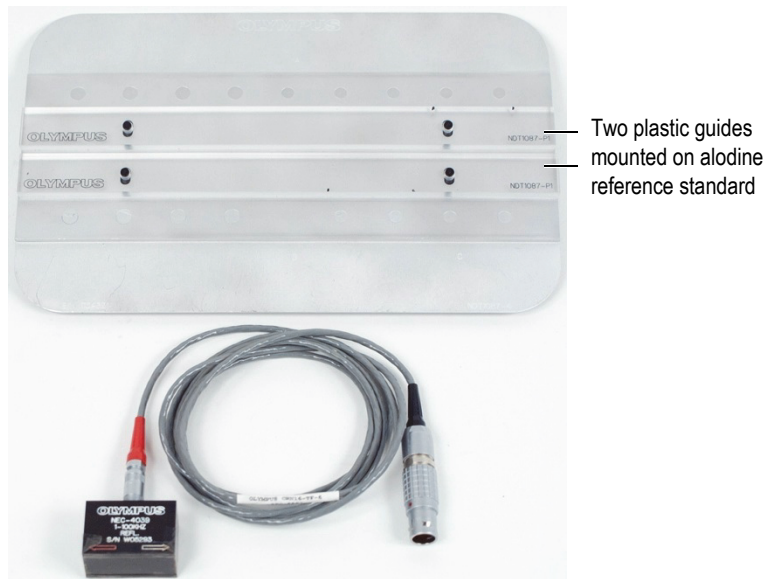

Figure 5-114 Materials—dual frequency for sub-surface cracks

The following products are used in this procedure:

- Sliding probe; P/N: NEC-4039 [U8633039]
- SPO-6687 cable for reflection coil configuration probes with triaxial Fischer/LEMO connector to NORTEC 500, 600, 1000, or 2000 series instrument (16 pin LEMO), 1.83 m (6 ft) length; P/N: SPO-6687 [U8800538]
- Special purpose anodized reference standard (P/N: NDT1087-4 [U8860779]) and plastic guides for alodine reference standard (two of P/N: NDT1087-P1 [U8860784])



To set up the plastic guides

- ◆ Adjust the plastic guides along the fastener rows on the alodine reference standard so that the sliding probe will be centered over the fasteners when sliding over the fastener row.

IMPORTANT

Make sure that the guides are properly adjusted for both fastener rows. Failure to properly center the probe will lead to a very difficult calibration and possibly an unusable setup.

To set the initial NORTEC 600 configuration

1. Connect the probe and the cable to the PROBE connector on the NORTEC 600.
2. Press the ADV SETUP menu key () once, and select **APPL SELECT** (A key) to open the application selection menu. Select **Dual Frequency Sub-Surface** with the knob, then press  to accept (see Figure 5-115 on page 209).

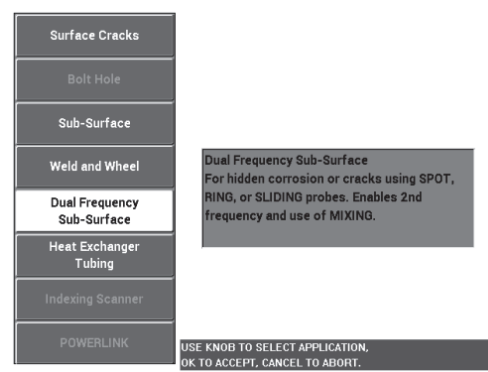









Figure 5-115 The Dual Frequency Sub-Surface application

3. Press the MAIN FILTER menu key () four times, and then set the **LO PASS** (B key) to 50 Hz using the knob.
4. Press the MAIN FILTER menu key () again, and then set the **PRB DRV** (A key) to **HIGH**.
5. Press the DISP menu key () twice, and then set the **POSITION** (C key) to **BOT RIGHT**.

6. Press the DISP menu key () again, and then set the **POS 2** (C key) to **BOT RGHT**.
7. Press the DISP menu key () again, and then set the **MIX DISP** (A key) to **OFF**.
8. Press the ADV SETUP menu key (), select **ALL SETTINGS** (B key), press the E key, and then the C key. Set the **RDG1 CHN** to **MIX**, press the FULL NEXT key () four times, and then set the **RDG2 TYP** to **OFF**. When done, press the Return key ().



The list of dual frequency parameters is shown in Figure 5-116 on page 210.

DUAL FREQUENCY					
SHAPE 1	BOX	ALARM 1	OFF	RDG1 CHN	MIX
TOP	100.0%	ALARM 2	OFF	RDG1 TYP	VMAX
BOTTOM	50.0%	ALARM 3	OFF	RDG1 LOC	BOT LEFT
LEFT	-10.0%			RDG2 CHN	MIX
RIGHT	50.0%			RDG2 TYP	OFF
				RDG2 LOC	BOT RIGHT
				TIME WIN	0.5sec
SHAPE 2	BOX	HORN	OFF		
TOP	50.0%	DWELL	0.0sec		
BOTTOM	30.0%			CAP MODE	INSTANT
LEFT	55.0%	EXT HORN	ON	CAP DLY	5.0sec
RIGHT	110.0%				
				AOUT PWR	OFF
SHAPE 3	BOX				
TOP	100.0%				
BOTTOM	70.0%				
LEFT	55.0%				
RIGHT	110.0%				

PRESS [A] FOR FIRST COL., [B] FOR SECOND COL., [C] FOR THIRD COL., [E] FOR PREV.

Figure 5-116 The list of dual frequency parameters

To calibrate the signals

1. Press the MAIN FILTER menu key (), and then set the **FREQ** (A key) to 9.0 kHz.
2. Press the MAIN FILTER menu key () again, and then set the **FREQ 2** (A key) to 2.2 kHz.
3. Place the probe on position 1 of the standard (see Figure 5-117 on page 211), and then press the A-LIFT NULL key ().

Make sure that the probe remains properly positioned between two fasteners.

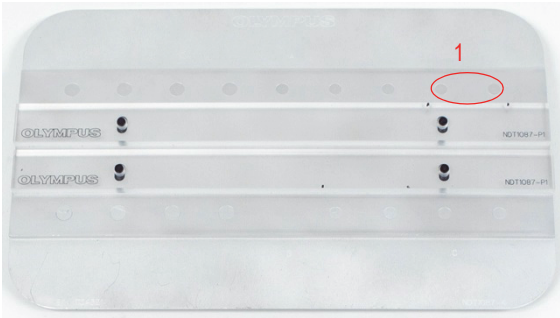

Figure 5-117 Position 1 on the standard



- 4. While holding the probe on position 1, insert two shims (business cards) under the probe.
- 5. While holding the probe in place, press the ANGLE key (), and then adjust the ANGLE until the signal is as horizontal as possible (20 % vertical) [see Figure 5-118 on page 211].



Figure 5-118 Adjusting the ANGLE value

- 6. While holding the probe in place, press the ANGLE key () again, and then adjust the ANGLE 2 so that it is also as horizontal as possible (see Figure 5-119 on page 212).

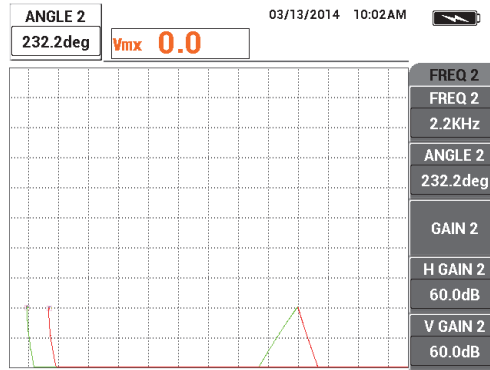

Figure 5-119 Adjusting the ANGLE 2 value

7. While still holding the probe, press the FREEZE key (❄️).
The probe and business cards can now be put aside.
8. Press the GAIN key (**dB**), and then adjust the amplitude of the frequency 1 signal so that it is exactly 6 divisions away from the null point (on the left side) [see Figure 5-120 on page 212].

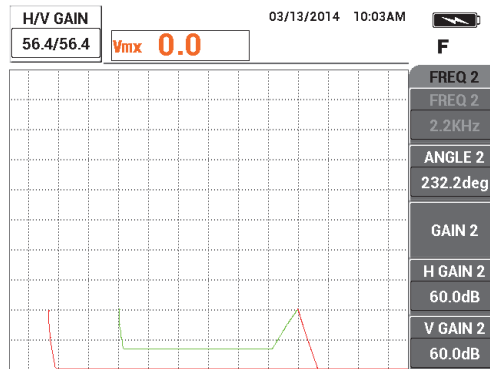

Figure 5-120 Adjusting the amplitude of the frequency 1 signal

9. Press the GAIN key (**dB**) three more times, and then decrease the amplitude of the frequency 2 signal so that it is exactly 6 divisions away from the null point (on the left side) [see Figure 5-121 on page 213].

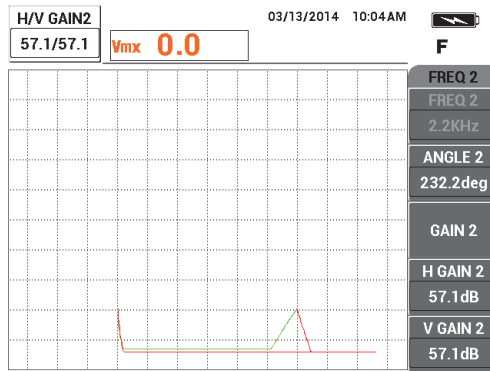

Figure 5-121 Adjusting the amplitude of the frequency 2 signal

10. Press the FREEZE key (❄) to unfreeze the acquisition.
11. Place the probe on position 1 of the standard (see Figure 5-117 on page 211), and then press the A-LIFT NULL key (⊕).
Always make sure that the probe is properly placed between two fasteners.
12. Scan the next fastener by moving the probe completely over the fastener, and then press the FREEZE key (❄).
The resulting signals should resemble the example shown in Figure 5-122 on page 214.

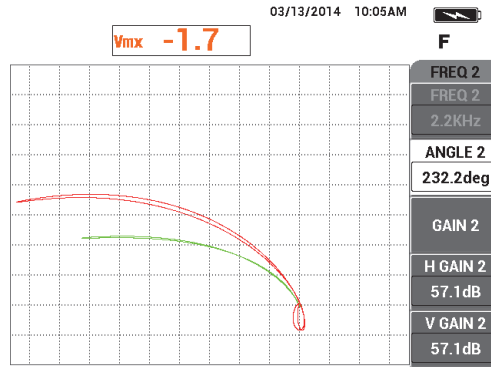

Figure 5-122 The fastener scan result

- Press the GAIN key (**dB**) twice, and then decrease the horizontal amplitude of the frequency 1 signal (green) until it extends exactly 5 divisions to the left of the null point (see Figure 5-123 on page 214).

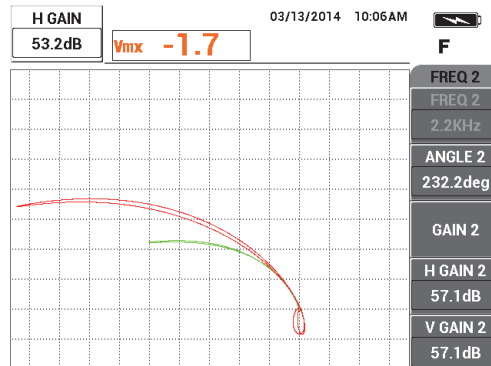

Figure 5-123 Adjusting the horizontal amplitude of the frequency 1 signal

- Press the GAIN key (**dB**) again, and then increase the vertical amplitude of the frequency 1 signal (green) until it extends exactly 4 divisions above the null point (see Figure 5-124 on page 215).

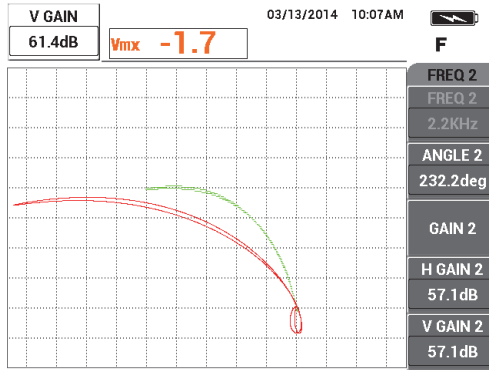

Figure 5-124 Adjusting the vertical amplitude of the frequency 1 signal

- Press the GAIN key (**dB**) twice again, and then decrease the horizontal amplitude of the frequency 2 signal (red) until it extends exactly 5 divisions to the left of the null point (see Figure 5-125 on page 215).

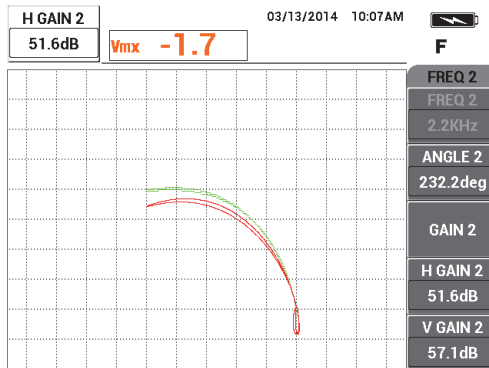

Figure 5-125 Adjusting the horizontal amplitude of the frequency 2 signal

- Press the GAIN key (**dB**) again, and then increase the vertical amplitude of the frequency 2 signal (red) until it extends exactly 4 divisions above the null point (see Figure 5-126 on page 216).

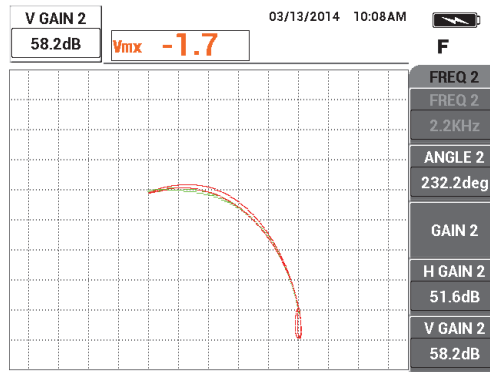

Figure 5-126 Adjusting the vertical amplitude of the frequency 2 signal

17. Press the FREEZE key (❄) to unfreeze the acquisition.
18. Press the DISP menu key (□), and then set the **DSP MODE** (A key) to **IMP**, the **CHANNEL** (B key) to **MIX**, and the **POSITION** (C key) to **BOT RIGHT**.
19. Press the MAIN FILTER menu key (✂) three times, and then set the **MIX ANG** (E key) to **180deg**.
20. Press the MAIN FILTER menu key (✂) repeatedly until the **FREQ 2** page is displayed.
21. Place the probe on position 3 (see Figure 5-127 on page 217), and then press the A-LIFT NULL key (⊕^{A-LIFT}).

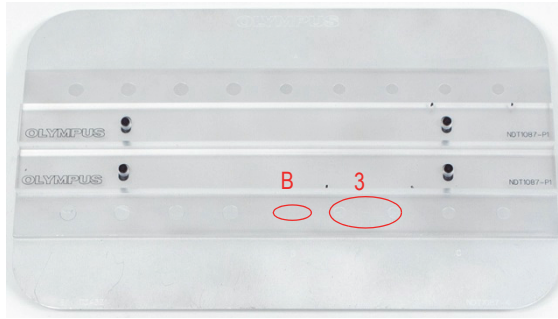

Figure 5-127 Position 3 on the standard

22. Move the probe over notch B, and then, while holding the probe at this position, adjust the **V GAIN 2** (E key) until the mix signal extends upward from the null point 4 vertical divisions (see Figure 5-128 on page 217).

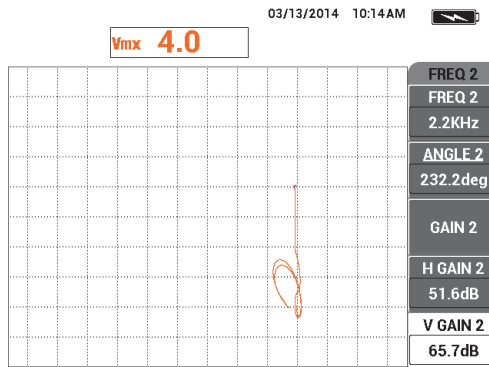



Figure 5-128 Adjusting the V GAIN 2 value

23. Press the MAIN FILTER menu key () repeatedly until the **FREQ 1** page is displayed.
24. Place the probe on position 1, press the A-LIFT NULL key (), and then move the probe back and forth over the next fastener on the left.

25. While constantly moving the probe, increase the **V GAIN** (E key) until the mix signal is contained within the first vertical division above the null point (see Figure 5-129 on page 218).

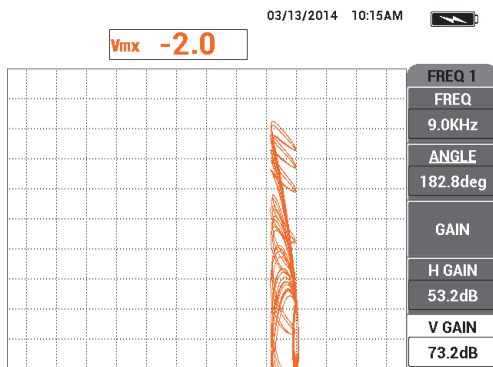



Figure 5-129 Adjusting the V GAIN value

26. If necessary, press the ERASE key () to check the mix signal (see Figure 5-130 on page 218).

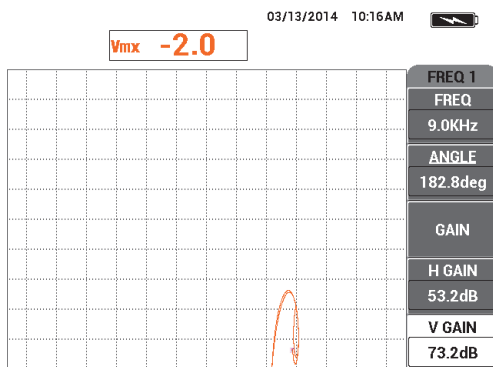



Figure 5-130 Checking the Mix signal

27. Place the probe on position 1 and then press the A-LIFT NULL key ().

28. While holding the probe on position 1, insert a shim (one business card) under the probe.
29. While firmly pressing the probe on the business card, adjust the **ANGLE** (B key) until the mix signal (orange) reaches the same vertical height as the null point (see Figure 5-131 on page 219).

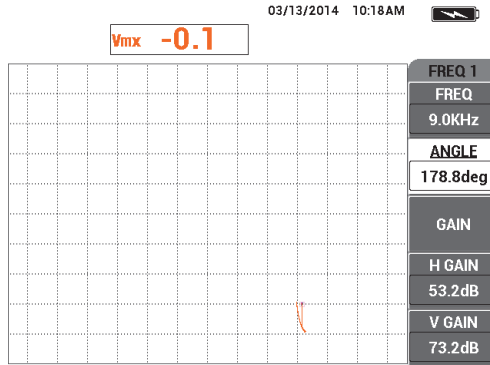



Figure 5-131 Adjusting the ANGLE value

30. Press the MAIN FILTER menu key () once.
31. While firmly pressing the probe on the business card, adjust the **H GAIN 2** (D key) until the mix signal extends about 5 horizontal divisions away from the null point (see Figure 5-132 on page 219).

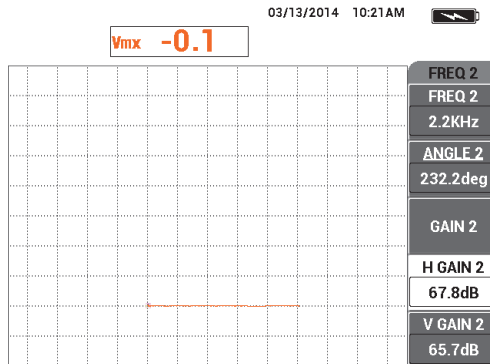





Figure 5-132 Adjusting the H GAIN 2 value

32. Depending on your requirements, press the DISP menu key () again, and then select your preferred **D ERASE** (A key) or **PERSIST** (B key) values.
33. Press the ALARM menu key () , and then set the **ALARM 1** (A key) to **MIX POS**.
34. Press the ALARM menu key () again, and then set the **BOTTOM** (C key) to 50 %, the **LEFT** (D key) to -10 %, and the **RIGHT** (E key) to 110 %.
35. Press the FULL NEXT key () to toggle to the full-screen mode.
36. Place the probe on position 1, and then perform a final scan of both fastener rows (see Figure 5-133 on page 220).

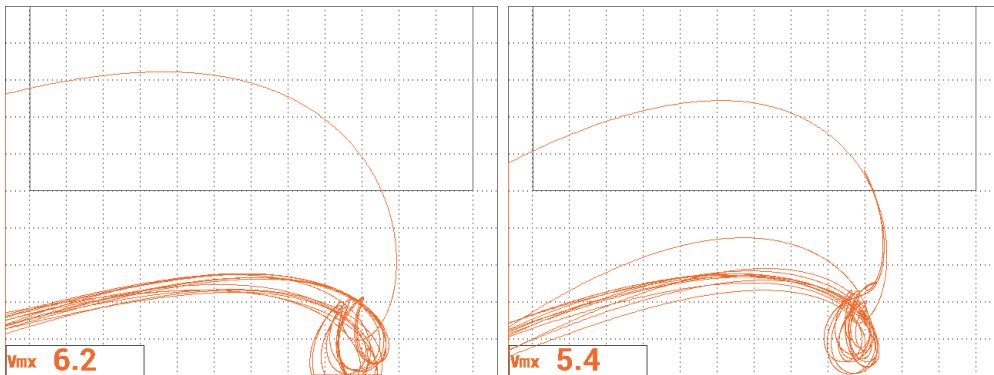

Figure 5-133 The scan results for both fastener rows

To fine-tune the instrument settings

- ◆ As desired, set the alarm box parameters, horn, or external horn (louder). For more details about alarms, see “Alarm Menus” on page 298.
The list of all parameters is shown in Figure 5-134 on page 221.

DUAL FREQUENCY			
FREQ MODE	DUAL	FREQ	9.0KHz
ID	No Probe	ANGLE	178.8deg
SERIAL #	No Probe	H GAIN	53.2dB
PRB CONN	LEMO-16	V GAIN	73.2dB
PRB DRV	HIGH	SIG1 DSP	MIX
HI PASS	OFF	H POS	80%
LO PASS	50Hz	V POS	20%
CONT NUL	OFF	SIG2 DSP	IMP
DSP MODE	IMP	H POS 2	80%
GRID	FINE	V POS 2	20%
PERSIST	OFF	SIG3 DSP	OFF
D ERASE	OFF	H POS 3	80%
SWP ERS	ON	V POS 3	50%
SWP MODE	AUTO Y	W START	1
SWP TIME	0.010sec	W END	32
SYNC ANG	0deg	W ERASE	MANUAL
SCAN RPM	0RPM	W CURSOR	1
FREQ 2	2.2KHz	MIX TYPE	F1 - F2
ANGLE 2	232.2deg	H MIX GN	0.0dB
H GAIN 2	67.8dB	V MIX GN	0.0dB
V GAIN 2	65.7dB	MIX ANG	180.0deg

DUAL FREQUENCY			
SHAPE 1	BOX	ALARM 1	MIX POS
TOP	100.0%	ALARM 2	OFF
BOTTOM	50.0%	ALARM 3	OFF
LEFT	-10.0%		
RIGHT	110.0%		
SHAPE 2	BOX	HORN	OFF
TOP	50.0%	DWELL	0.0sec
BOTTOM	30.0%		
LEFT	55.0%	EXT HORN	ON
RIGHT	110.0%		
SHAPE 3	BOX		
TOP	100.0%		
BOTTOM	70.0%		
LEFT	55.0%		
RIGHT	110.0%		
RDG1 CHN	MIX	CAP MODE	INSTANT
RDG1 TYP	VMAX	CAP DLY	5.0sec
RDG1 LOC	BOT LEFT	ADUT PWR	OFF
RDG2 CHN	MIX		
RDG2 TYP	OFF		
RDG2 LOC	BOT RIGHT		
TIME WIN	0.5sec		

PRESS [A] FOR FIRST COL, [B] FOR SECOND COL, [C] FOR THIRD COL, [E] FOR NEXT. PRESS [A] FOR FIRST COL, [B] FOR SECOND COL, [C] FOR THIRD COL, [E] FOR PREV.

Figure 5-134 The list of all parameters

5.3.3 Inspecting Heat Exchanger Tubing Using Dual Frequency — NORTEC 600D Model

The procedure in this section uses the dual frequency function to remove the heat exchanger's tube-support signal in order to obtain cleaner readings of possible flaws at support locations. You can use this procedure on any type of heat exchanger tubing as long as it is non-ferromagnetic. Although this procedure has been prepared using a differential bobbin probe, other types of tube probe coils can also easily be used; for example, differential pancake coils for air conditioner tubing. Several tips for absolute measurements have been provided at the end of this section.

The frequency calculation for the prime frequency should follow the ASME standard or be based on obtaining at least a 90° phase lag between the thru-wall hole and the 20 % outside flat-bottom holes. The following formula is also recommended:

$$\text{Prime frequency} = 5 \times \text{resistivity} / (\text{wall thickness})^2$$

where

- Resistivity is in micro-ohm centimeters ($\mu\Omega\text{-cm}$);
- Wall thickness is in millimeters (mm); and
- Frequency is in kilohertz (kHz).

The subtracting frequency should be at least half of the prime frequency. However, since the NORTEC 600 allows fully independent frequencies, the best results are obtained with a ratio of 4:1 between the highest and lowest frequency. This section's procedure has been prepared with frequency 1 as the highest frequency, though the NORTEC 600 will function equally as well with frequency 2 as the highest frequency.

Inspection materials are shown in Figure 5-135 on page 222.



Figure 5-135 Materials—dual frequency for heat exchanger tubing

The following products are used in this procedure:

- Eddy current bobbin probe for heat exchanger tubing: absolute/differential, 14.8 mm (0.583 in.) diameter, 15 kHz center frequency, 20 m (65.6 ft) cable; P/N: TEA-148-015-N05 [U8282109]

- Tube probe adapter (differential) including NULL and ERASE foot switch (P/N: N600-TUBE-FTSW [U8779875]) and auxiliary absolute tube adapter (P/N: DGL-AF4-BNC-8 [U8779886])
- Admiralty brass calibration standard (tube): OD 19 mm (0.75 in.), WT (wall thickness) 1.65 mm (0.065 in.); P/N: CT02-001-D16 [U8779241]

To set the initial NORTEC 600 configuration

1. Connect the probe and the foot-switch adapter cable to the PROBE connector on the NORTEC 600.
2. Press the ADV SETUP menu key () once, then select **APPL SELECT** (A key) to open the application selection menu. Select **Heat Exchanger Tubing** with the knob, then press ✓ to accept (see Figure 5-136 on page 223).

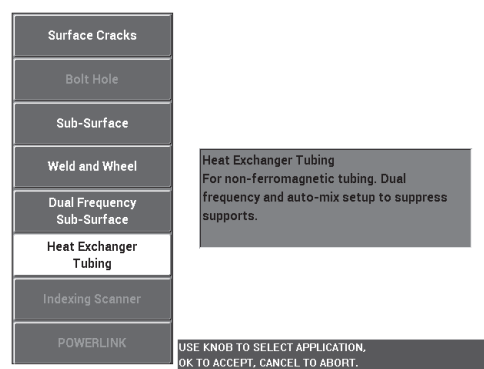



Figure 5-136 The Heat Exchanger Tubing application

3. Press the MAIN FILTER menu key (), and then set the **FREQ** (A key) to 14 kHz.
4. Press the MAIN FILTER menu key () again, and then set the **FREQ 2** (A key) to 3 kHz.

To calibrate the signals

1. Place the probe in a defect-free zone of the calibration standard, and then press the NULL foot switch.

- Slowly scan the smallest thru-wall hole only, pressing the ERASE foot switch as required to clear the screen. When the hole signal is visible on the NORTEC 600 screen, press the FREEZE key (❄️). See Figure 5-137 on page 224.

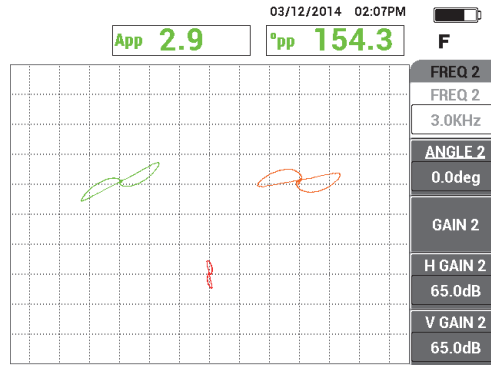

Figure 5-137 The scan of the thru-wall hole

- Press the ANGLE key (◁/0), and then rotate the frequency 1 signal (green) until the hole signal reaches a phase of about 40° (see Figure 5-138 on page 225).

TIP

When scanning over the hole in a pulling motion, the probe's lower signal lobe should appear first on the screen.

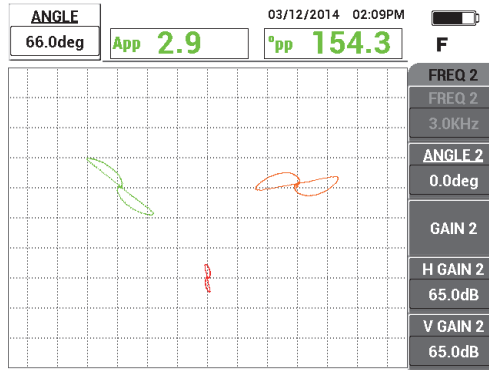

Figure 5-138 Adjusting the frequency 1 signal phase

4. Press the GAIN key (**dB**), and then increase the frequency 1 gain until the hole signal reaches about 4 vertical divisions in height (see Figure 5-139 on page 225).

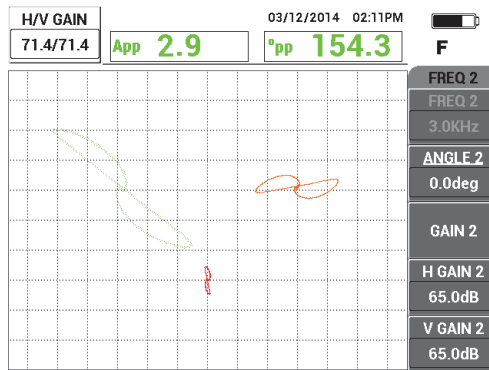



Figure 5-139 Adjusting the frequency 1 gain

5. Press the ANGLE key () twice, and then adjust the angle of the frequency 2 signal (red) until the hole signal is oriented almost vertically (see Figure 5-140 on page 226).
Make sure that the lower signal lobe appears first on the screen while scanning with a pulling motion.

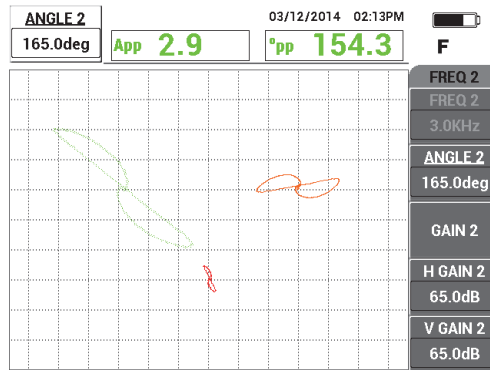

Figure 5-140 Adjusting the frequency 2 angle

6. Press the FREEZE key (❄) to unfreeze the acquisition.
7. Place the probe in a defect-free area near the tube's support ring, and then press the NULL foot switch. Scan the support ring and press the FREEZE key (❄) when done (see Figure 5-141 on page 226).

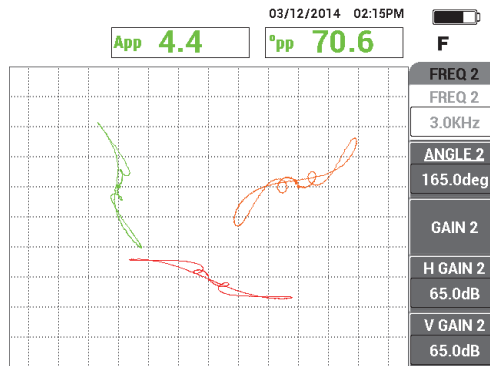

Figure 5-141 The scan of the support ring

8. Press the ANGLE key (◁) twice, and then set the support ring's frequency 2 signal angle (red) so that it is nearly horizontal (see Figure 5-142 on page 227).

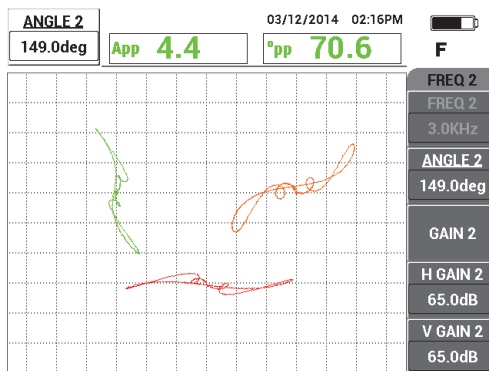

Figure 5-142 Adjusting the angle of the frequency 2 signal on the support ring

9. Press the GAIN key (**dB**) four times, and then adjust the H/V GAIN 2 until the support ring's frequency 2 signal extends across approximately 10 horizontal divisions on the screen (see Figure 5-144 on page 228).

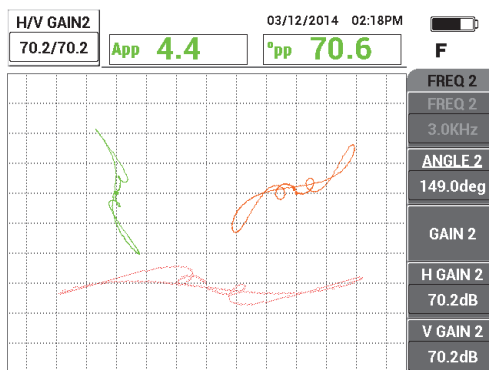

Figure 5-143 Adjusting the gain of the frequency 2 signal on the support ring

10. Press the FREEZE key (❄) to unfreeze the acquisition.
11. Press the MAIN FILTER menu key (🌀) repeatedly until the **MIX** menu is displayed.

12. Place the probe in a defect-free area near the support ring, and then press the NULL foot switch.
13. Press the **AUTO MIX** key (B key), and then slowly scan the support ring.
The NORTEC 600 records 5 seconds of the support ring's signal and automatically performs signal mixing (see Figure 5-144 on page 228).

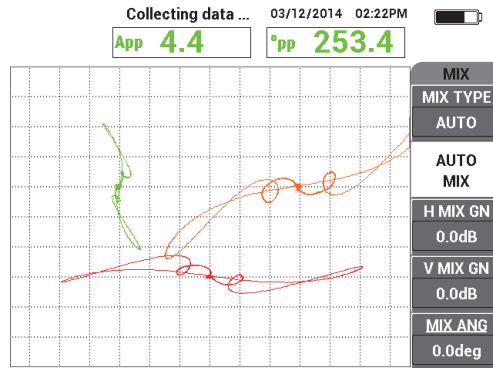

Figure 5-144 The support ring scan with AUTO MIX

14. If necessary, repeat step 13 to practice scanning the support ring at the proper speed.
15. Press the ERASE foot switch, and then scan the tube's support ring again.
The **MIX** channel (orange) should display a very small, or nearly absent, support signal (see Figure 5-145 on page 229).

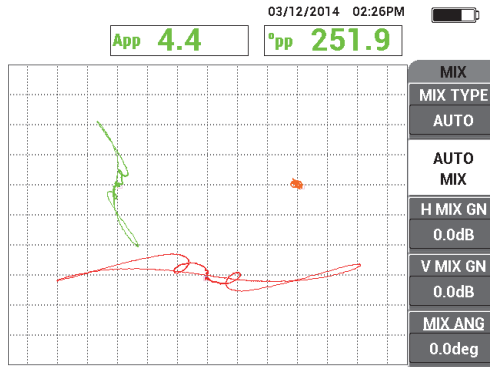

Figure 5-145 The support ring's signal successfully subtracted

16. Place the probe next to the thru-wall hole, press the NULL foot switch, and then scan the hole using a pulling motion (see Figure 5-146 on page 229).

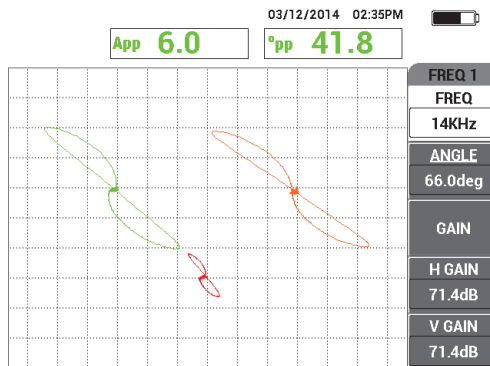

Figure 5-146 The scan of the thru-wall hole

To fine-tune the instrument settings

1. Improve the already-functional configuration by fine-tuning the settings:
 - a) Fine-tune the frequency 1 angle to obtain a 40.0 degree reading from the hole.
 - b) Change the real-time readings so that the **MIX** phase is displayed (for more information, see “MIX Menu in Dual Frequency – MAIN FILTER Key” on page 119).

- c) Fine-tune the **MIX** angle (on the **MIX** page of the **MAIN FILTER** menu) to also obtain 40.0 degrees or very close to this value (see Figure 5-147 on page 230).

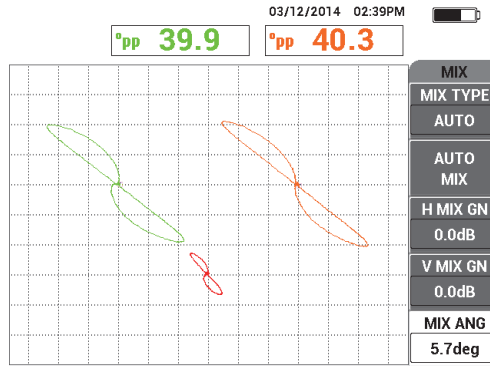



Figure 5-147 Fine-tuning the MIX angle

- Press the FULL NEXT key () to activate the full-screen mode, and then scan the five flat-bottom holes. The signal should resemble the image shown in Figure 5-148 on page 230. The list of all parameters is shown in Figure 5-149 on page 231.

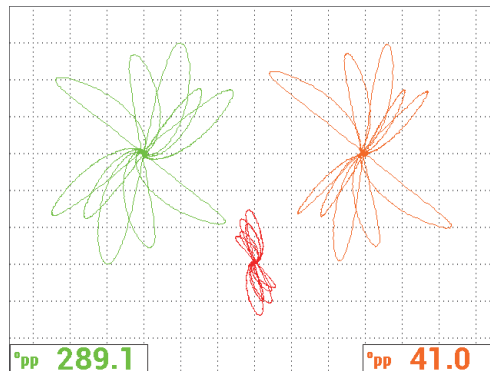

Figure 5-148 The scan of the flat-bottom holes

DUAL FREQUENCY			
FRQ MODE	DUAL	FREQ	14KHz
ID	No Probe	ANGLE	65.1deg
SERIAL #	No Probe	ANGLE 2	149.0deg
PRB CONN	LEMO-16	H GAIN	71.4dB
PRB DRV	HIGH	H GAIN 2	70.2dB
HI PASS	OFF	V GAIN	71.4dB
LO PASS	500Hz	SIG1 DSP	IMP
CONT NUL	OFF	H POS	20%
DSP MODE	ALL-IN-1	V POS	60%
GRID	FINE	SIG2 DSP	IMP
PERSIST	OFF	H POS 2	50%
D ERASE	OFF	V POS 2	30%
SWP ERS	ON	SIG3 DSP	IMP
SWP MODE	AUTO Y	H POS 3	80%
SWP TIME	0.300sec	V POS 3	60%
SYNC ANG	0deg	MIX TYPE	AUTO
SCAN RPM	0RPM	H MIX GN	0.0dB
		V MIX GN	0.0dB
		MIX ANG	5.7deg
		W START	1
		W END	32
		W ERASE	MANUAL
		W CURSOR	1

DUAL FREQUENCY			
SHAPE 1	SECTOR	ALARM 1	OFF
OUTR DIA	264%	ALARM 2	OFF
INNER DIA	25%	ALARM 3	OFF
STRT ANG	15deg		
END ANG	180deg		
		RDG1 CHN	FREQ 1
		RDG1 TYP	DEG PP
		RDG1 LOC	BOT LEFT
		RDG2 CHN	MIX
		RDG2 TYP	DEG PP
		RDG2 LOC	BOT RIGHT
		TIME WIN	0.5sec
SHAPE 2	SWEEP	HORN	OFF
TOP	30.0%	DWELL	0.0sec
BOTTOM	10.0%		
		EXT HORN	ON
		CAP MODE	INSTANT
		CAP DLY	5.0sec
SHAPE 3	POLAR		
RADIUS	15.0%		
HORZ	80.0%		
VERT	60.0%		
		ADUT PWR	OFF

PRESS [A] FOR FIRST COL, [B] FOR SECOND COL, [C] FOR THIRD COL, [E] FOR NEXT. PRESS [A] FOR FIRST COL, [B] FOR SECOND COL, [C] FOR THIRD COL, [E] FOR PREV.

Figure 5-149 The list of all parameters

To activate alternate displays

- Depending on your requirements, change the display parameters to display the frequency 2 as a strip chart (sweep) by pressing the DISP menu key () three times and setting the **FRQ2 DSP** (A key) to **AUTO Y** (see Figure 5-150 on page 232).
If necessary, adjust the **SWP TIME** (C Key) to display a longer sweep length.

TIP

Display the full tube length so that you can count the tube supports, and set the **V POS 2** (E key) as desired; for example, you can separate the signals so that they do not interfere with each other.

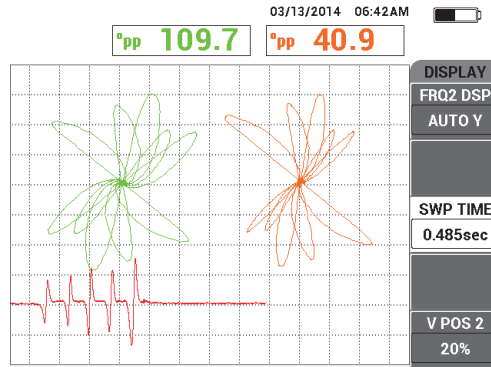





Figure 5-150 The strip chart display

2. Depending on your requirements, switch to the **MIX** channel (alone) with the **WEB** grid by pressing the DISP menu key () repeatedly until the **DISPLAY** page is shown and then setting the **DSP MODE** (A key) to **IMP**.
3. Set the **CHANNEL** (B key) to **MIX**, and then set the **POSITION** (C key) to **CENTER**.
4. Press the DISP menu key () again, set the **GRID** (D key) to **WEB**, press the FULL NEXT key () to toggle to the full-screen mode, and then scan the tube. The web grid helps you quickly visualize the signal angle (see Figure 5-151 on page 233).

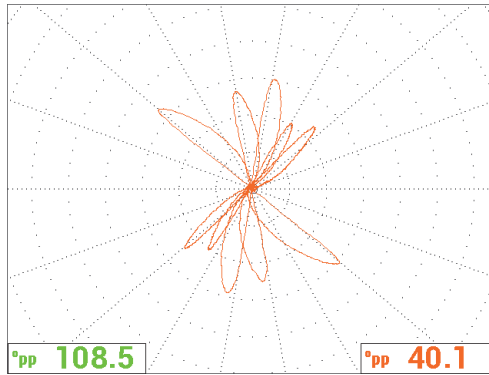



Figure 5-151 The web grid display

Absolute measurement

Absolute measurements can be obtained easily with the NORTEC 600 by using its BNC connector. Absolute signals are useful for monitoring gradual or large defects, such as erosion, corrosion, fretting wear, bulges, defects at expansion roll, etc. Although it is possible to apply the above procedure to absolute signals, the best results are generally obtained using lower frequencies starting at half the prime frequency. Note that absolute response is generally not recommended for small defects, such as the flat bottom holes in the calibration standard (tube).

To perform absolute measurements

1. While keeping the foot switch adapter connected to the NORTEC 600, disconnect the probe from the foot switch adapter and connect it to the BNC adapter (P/N: DGL-AF4-BNC-8 [U8779886]), which you must then connect to the instrument.
2. Load the **Heat Exchanger Tubing** application from the application selection menu (see step 2).
3. Press the MAIN FILTER menu key () repeatedly until the **SPECIAL** page is displayed, and then set the **PRB CONN** to **BNC**.
4. Follow steps 1–16 to calibrate the signals.

TIP

To generate an alternative useful signal display, you can lower the null point (for example, to a near-bottom center position on the screen) and activate the **COARSE** grid (see Figure 5-152 on page 234). With these adjustments, you can expect lower instrument gain settings.

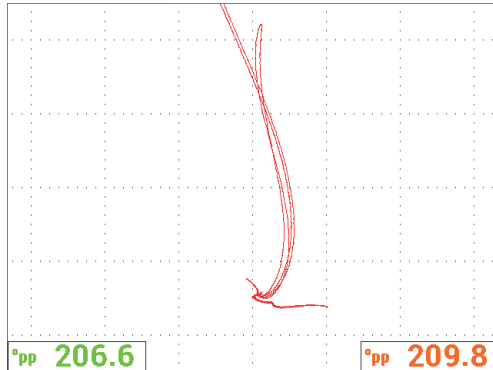

Figure 5-152 The display with adjusted null point and coarse grid

5.4 Heat Exchanger Tubing Applications

The NORTEC 600 can be used to inspect various types of heat exchanger tubing composed of different alloys. Although small in size, the instrument contains many useful features previously only available in other, more advanced products.

The heat exchanger tubing applications are only available on the NORTEC 600D model with dual frequency. The applications also require dedicated, specially-configured adapters, which are listed in Table 16 on page 350.

Table 4 on page 235 contains a list of recommended technologies and probes.

Table 4 Recommendations for heat exchanger tubing applications

Tube material and type	Compatible magnetic technology	Compatible Evident tube probe series	Remarks
Nonferromagnetic (copper, brass, aluminum, titanium, 300 series stainless steel, Inconel, and others)	Eddy current (ECT)	TEA/TEB, TEE/TEF, TEG, TEK/TEL	Virtually any bobbin-type probe from Evident or other manufacturers can be used.
Ferromagnetic (carbon steels, nickel)	Remote field (RFT)	TRS, TRX	Use single exciter (TRS) for erosion/corrosion. Use dual exciter (TRX) for pitting.
Mildly ferromagnetic (Monel, 400 series stainless steel, Duplex stainless steel)	ECT or RFT	TEO or TRX	Higher frequency TRX dual exciter probes are recommended; they are easier to use and procure.
Carbon steel finned tubing (typically finned air-coolers; tubes are wrapped with aluminum fins)	Near field (NFT)	TRD	RFT will NOT work because the entire magnetic field is absorbed in the fins.
Stainless steel finned tubing (typically with aluminum fins wrapped around tube)	Eddy current (ECT)	TEA/TEB, TEE/TEF	Set frequency high enough (500 kHz) to inspect internal surface only. No penetration is possible. An alternative is IRIS (ultrasound).
Air conditioner (A/C) [chiller or evaporator] finned copper tubing	Eddy current (ECT)	TEA/TEB, TEC/TED	Regular bobbin probes are often used; however, A/C probes or similar competing models will detect circumferential cracking.

NOTE

For the calibration steps in these applications, you can obtain the best results if you are familiar with your calibration standard (tube). It is strongly recommended that you review the calibration standard before each inspection application and mark the null or flaw positions on the probe's polyethylene tubing. To do this, you can place the probe with tubing along the outside of the calibration standard. With the probe placed next to the null or flaw location, make a reference mark on the polyethylene tubing (at the calibration standard entrance) using a permanent marker or tape (see Figure 5-153 on page 236).

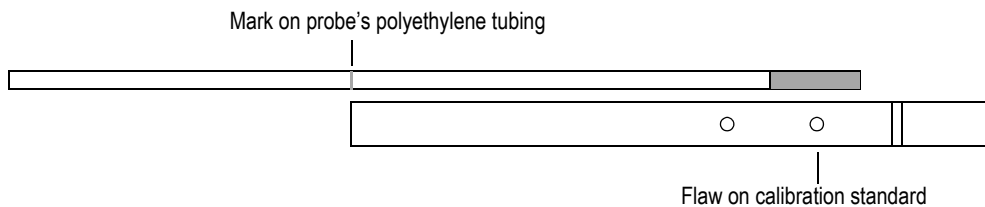

Figure 5-153 An example of marking the probe positions

5.4.1 ECT Pitting, Wear, and Cracks — NORTEC 600D Model

In this application, an eddy current “bobbin” probe is used to identify localized, small defects such as pitting, wear, and cracks in tubing made of nonferromagnetic alloys.

ECT is a noncontact method in which the probe is excited with an alternating current, inducing eddy currents in the part being inspected (see Figure 5-154 on page 237). Any discontinuities or material property variations that change the eddy current flow in the part are detected as potential defects by the probe. This technique is suitable for the detection and sizing of metal discontinuities such as corrosion, erosion, wear, pitting, baffle cuts, and wall loss. ECT is also suitable for detecting cracks in nonferrous materials such as austenitic stainless steel (for example, types 304 and 316), brass, copper-nickel, titanium, copper-fin, and Inconel.

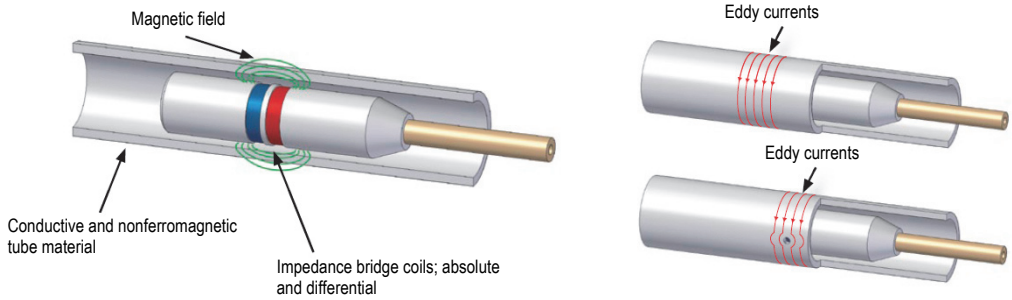

Figure 5-154 ECT principles

The eddy currents interact as follows:

- Two coils are excited with an electrical current, producing a magnetic field around them. The magnetic fields penetrate the tube material and generate opposing alternating currents within the material. These currents are called eddy currents.
- Any defects that change the eddy current flow will also change the impedance of the coils in the probe.
- The changes in the impedance of the coils are measured and used to detect defects in the tube.

This application uses a probe adapter that is configured for differential mode. The differential configuration subtracts the signals obtained by both coils and, as such, is ideal for detecting smaller discontinuities such as pitting, but also shorter discontinuities such as wear under a support (see Figure 5-155 on page 238). The differential configuration, however, cannot be used to detect longer or gradual discontinuities for the simple reason that the discontinuity signal is “subtracted” (diminished) and therefore not useful. To detect longer or gradual discontinuities, absolute mode must be used.



Figure 5-155 An example of an ECT differential signal response

The differential configuration is widely employed to connect air conditioner (A/C) probes. Differential configurations are also used in cross-axis coil probes, which are used to inspect copper finned tubes in air conditioner units. Although not illustrated here, cross-axis coil probes are used in a similar way as A/C probes, but they typically require 10 dB to 20 dB more gain than A/C probes, and a 100 Hz low-pass (LP) filter.

Figure 5-156 on page 238 shows an example of an A/C probe. Figure 5-156 on page 238 shows an example of signals from an A/C probe's pancake coils.

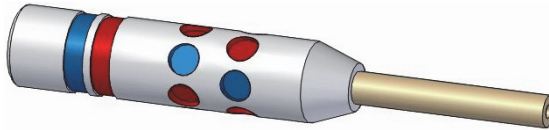

Figure 5-156 An air conditioner probe

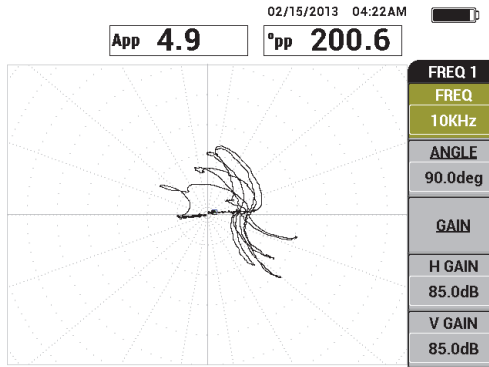

Figure 5-157 Signals from an A/C probe’s pancake surface coils only

5.4.1.1 Using the Application

This application uses inspection materials similar to the example illustrated in Figure 5-135 on page 222 (in the application “Inspecting Heat Exchanger Tubing Using Dual Frequency — NORTEC 600D Model” on page 221).

The following products are used in this procedure:

- Eddy current bobbin probe for heat exchanger tubing: absolute/differential, 14.8 mm (0.583 in.) diameter, 15 kHz center frequency, 20 m (65.6 ft) cable; P/N: TEA-148-015-N05 [U8282109]
- Differential and absolute eddy current probe adapter; P/N: CBAS-10818-0001 [Q7670051]
- Admiralty brass calibration standard: OD 19 mm (0.75 in.), WT (wall thickness) 1.65 mm (0.065 in.); P/N: CT02-001-D16 [U8779241]
- Convenient, highly recommended items (however, not mandatory): foot switch (P/N: 9522333 [Q7670007]), foot switch armored cable (P/N: 9122404 [Q7670008]), and foot switch adapter (P/N: 9522336 [Q2500083])

To set the initial NORTEC 600 configuration

1. Connect the adapter, probe, and foot-switch adapter cable to the PROBE connector on the NORTEC 600.

- Select **CONTINUE** (press the A key) to open the application selection menu, and then use the knob to select **ECT Pitting, Wear, and Cracks**, and press ✓ to accept (see Figure 5-158 on page 240).

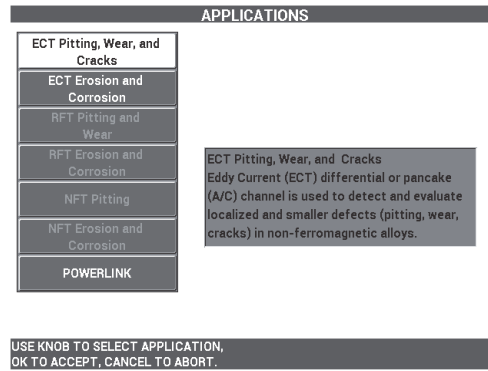

Figure 5-158 The ECT Pitting, Wear, and Cracks application

To calibrate the signals for frequency 1

- Place the probe in a defect-free zone of the calibration standard near the small thru-wall hole (1.3 mm [0.052 in.]), and then press the NULL foot switch.
- Slowly scan the smallest thru-wall hole only, pressing the ERASE foot switch as required to clear the screen. When the hole signal is visible on the NORTEC 600 screen, press the FREEZE key (❄).

TIP

When scanning over the hole in a pulling motion, the probe's lower signal lobe should appear first on the screen (see Figure 5-159 on page 241 and Figure 5-160 on page 241).

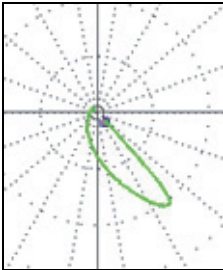

Figure 5-159 Example of lower signal lobe when pulling the probe over a flaw

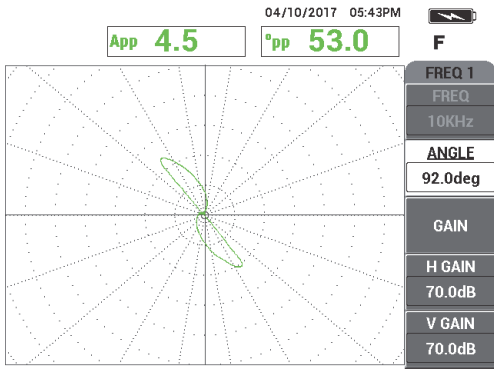

Figure 5-160 The scan signal of the thru-wall hole

3. Press the ANGLE key () , and then rotate the frequency 1 signal (green) until the hole signal reaches a phase of about 40° (see Figure 5-161 on page 242).

TIP

Choose the polar (**WEB**) grid shown in this example to make it easier to adjust the phase angle and gain. (For details on grid selection, see “GRID” on page 96.) Each major graticule represents 20° and 10 % of full-screen height.

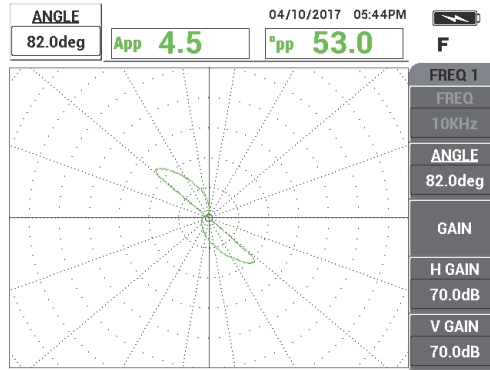

Figure 5-161 Adjusting the signal

Adjusting the frequency 1 signal phase

4. Press the **GAIN** key (**dB**), and then increase the frequency 1 gain until the hole signal reaches about 6 vertical divisions in height (see Figure 5-162 on page 242). If necessary, adjust the **ANGLE** after you have increased the gain.

IMPORTANT

Always use combined horizontal and vertical gain (**H/V GAIN**).

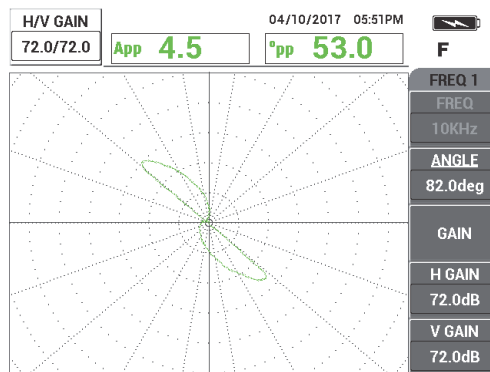

Figure 5-162 Adjusting the frequency 1 gain

5. Press the FREEZE key (❄) to enable signal acquisition.
6. Place the probe in a defect-free area of the calibration standard, near the tube's support ring, and then press the NULL foot switch.
7. Slowly scan the support ring, pressing the ERASE foot switch as required to clear the screen. When the support ring signal is visible on the NORTEC 600 screen, press the FREEZE key (❄).
8. If the support ring signal exceeds 80 % of full-screen height, press the GAIN key (dB) and lower the gain.

IMPORTANT

The support ring signal should not exceed 80 % of full-screen height, or it may effect steps later in the application. This type of signal is referred to as "saturated." Examples of nonsaturated and saturated support ring signals are shown in Figure 5-163 on page 243 and Figure 5-164 on page 244.

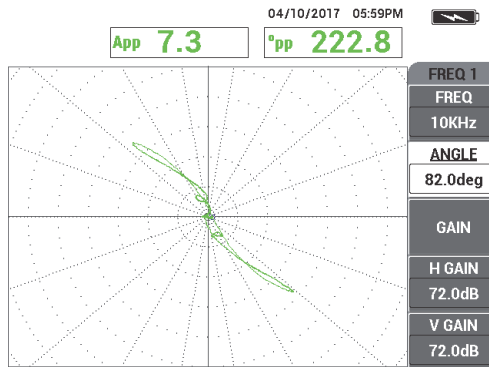

Figure 5-163 An example of a nonsaturated support ring signal

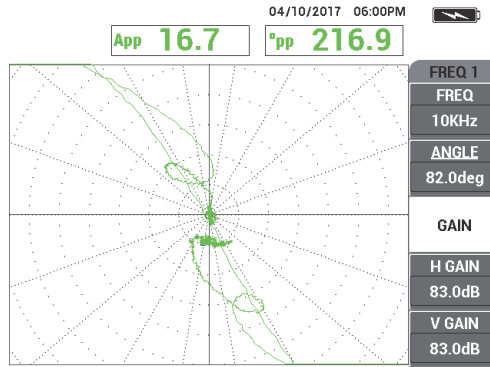

Figure 5-164 An example of a saturated support ring signal

9. Press the FREEZE key (❄️) to enable signal acquisition, and then press the NULL foot switch.
10. Scan the tube between the support ring and the 1.3 mm (0.052 in.) thru-wall hole to verify the frequency 1 calibration (see Figure 5-165 on page 244).

For improved clarity, the verified signals of the thru-wall hole and the support ring are shown next to each other in Figure 5-166 on page 245.

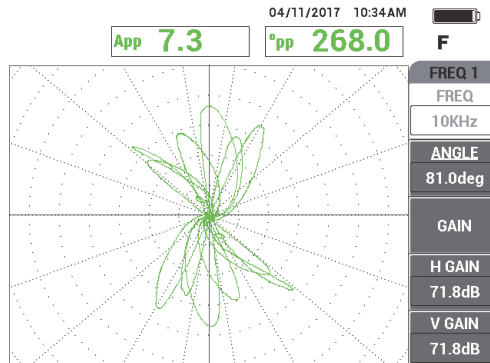

Figure 5-165 The tube scan between the support ring and the thru-wall hole

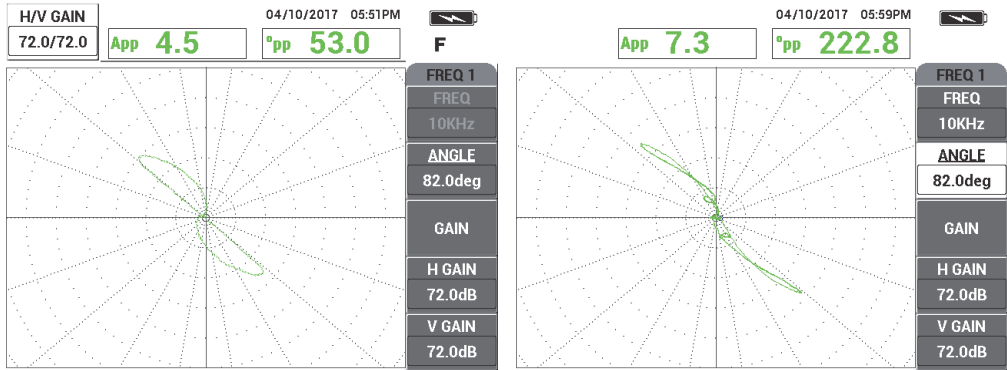





Figure 5-166 The verified signals: thru-wall hole (*left*) and support ring (*right*)

To calibrate the signals for frequency 2

1. Press the DISP menu key () , followed by CHANNEL (B key), and then rotate the knob until **FRQ2** is displayed.
2. Access the **MIX** menu by pressing the MAIN FILTER menu key () twice to check the frequency 2 value.

NOTE

When you use the **MIX** function, the frequency 2 value must be at least one-half of the frequency 1 value.

3. Place the probe in a defect-free area near the tube's support ring, and then press the NULL foot switch.
4. Scan the support ring and, if necessary, adjust the combined gain (**H/V GAIN 2**) of frequency 2 to make sure that the signal does not exceed 80 % of full-screen height.
5. When you obtain a satisfactory signal, press the FREEZE key () to enable signal acquisition (see Figure 5-167 on page 246).

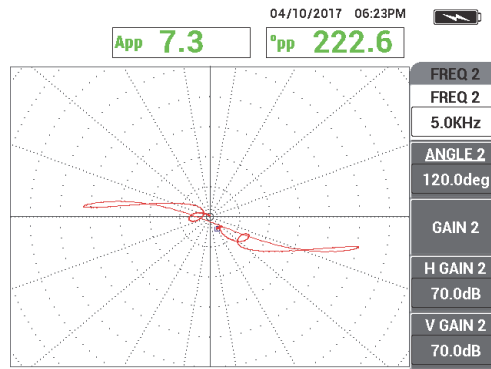

Figure 5-167 The frequency 2 scan signal of the support ring

- Slowly scan the 1.3 mm (0.052 in.) thru-wall hole only, pressing the ERASE foot switch as required to clear the screen. When the hole signal is visible on the NORTEC 600 screen, press the FREEZE key (❄) [see Figure 5-168 on page 246].

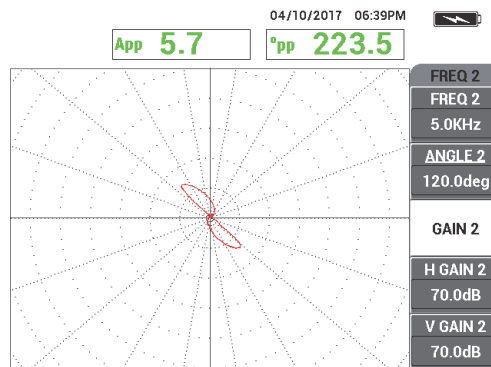

Figure 5-168 The frequency 2 scan signal of the 1.3 mm (0.052 in.) thru-wall hole

- Press the ANGLE key (◁), and then rotate the frequency 2 signal until the hole signal reaches a phase of approximately 40°.

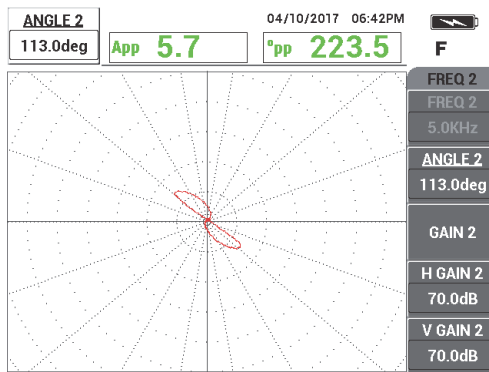

Figure 5-169 The frequency 2 scan signal of the 1.3 mm (0.052 in.) thru-wall hole with adjusted angle

8. Press the FREEZE key (❄) to enable signal acquisition.
9. Place the probe in a defect-free area near the support ring, and then press the NULL foot switch.
10. Scan the support ring to verify that the signal is below 80 % full-screen height after the angle adjustment for the 1.3 mm (0.052 in.) thru-wall hole.

To record and cancel the support signal using AUTO MIX

1. Press the DISP menu key (□), followed by CHANNEL (B key), and then rotate the knob until the MIX menu is displayed.
2. Press the MAIN FILTER menu key (✂) three times.
3. Place the probe in a defect-free area near the tube's support ring, and then press the NULL foot switch.
4. Press AUTO MIX (B key), and slowly scan the support ring.

IMPORTANT

The **AUTO MIX** function is automatic and records the signal for 5 seconds after **AUTO MIX** (B key) has been pressed.

5. Verify that **AUTO MIX** has acquired the support ring signal:

- a) Place the probe in a defect-free area near the tube's support ring, and then press the NULL foot switch.
- b) Slowly scan the support ring and check the signal.
If **AUTO MIX** was correctly performed, you will not see any signal from the support ring (see Figure 5-170 on page 248).

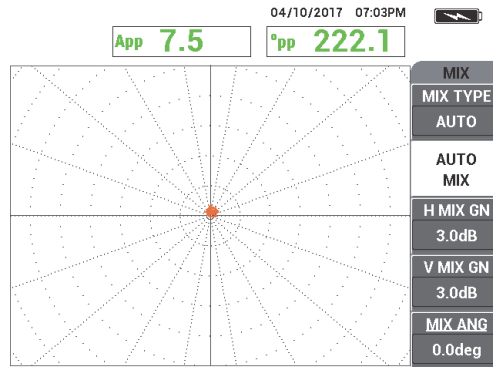

Figure 5-170 The support ring signal after AUTO MIX

6. Place the probe in a defect-free zone of the calibration standard near the small thru-wall hole (1.3 mm [0.052 in.]), and then press the NULL foot switch.
7. Slowly scan the 1.3 mm (0.052 in.) thru-wall hole only, pressing the ERASE foot switch as required to clear the screen. When the hole signal is visible on the NORTEC 600 screen, press the FREEZE key (❄) [see Figure 5-171 on page 249].

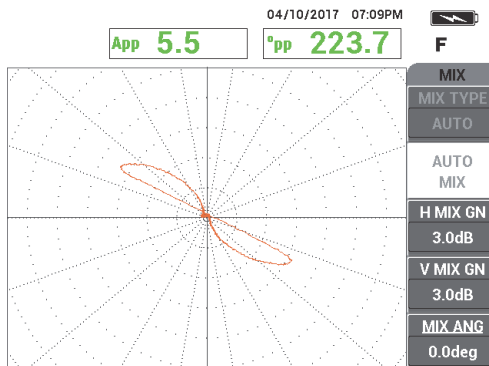

Figure 5-171 The thru-wall hole signal after AUTO MIX

8. Press **MIX ANGLE** (E key), and then rotate the **MIX** signal until the hole signal reaches a phase of approximately 40° (see Figure 5-172 on page 249).

NOTE

The direct function keys on the left side of the instrument screen do not function while the **MIX** menu is being used.

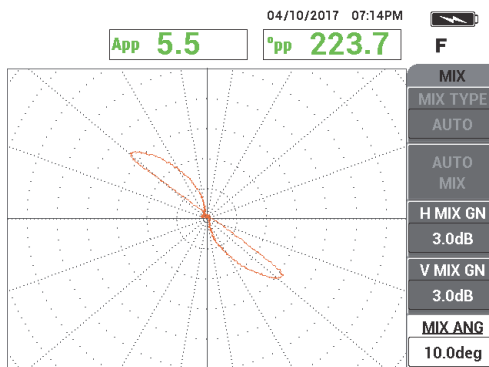

Figure 5-172 The thru-wall hole signal after AUTO MIX angle adjustment

9. Adjust **H MIX GN** (horizontal MIX gain, C key) and **V MIX GN** (vertical MIX gain, D key) until the signal extends across approximately 6 major divisions on the grid (see Figure 5-173 on page 250).

IMPORTANT

Combined horizontal and vertical gain adjustment is not available while using the **MIX** menu. Adjustments to horizontal and vertical gain must be made separately and equally.

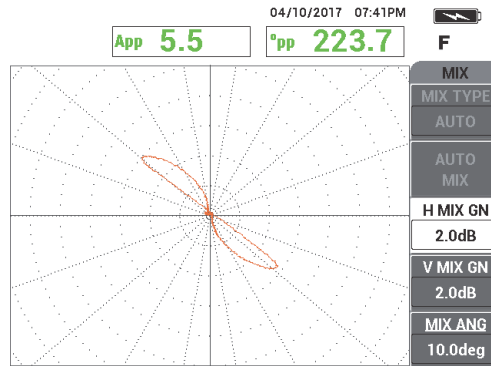

Figure 5-173 The thru-wall hole signal after AUTO MIX gain adjustment

10. Press the FREEZE key (❄️) to enable signal acquisition.
11. Place the probe in a defect-free area near the tube's support ring, and then press the NULL foot switch.
12. Scan the tube for defects (see Figure 5-174 on page 251).

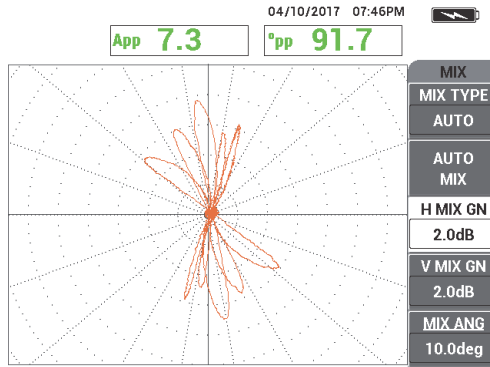



Figure 5-174 The tube scan result

13. When you are satisfied with the setup, press the REF SAVE ( ^{REF}) key.

NOTE

The file will be saved with a time/date stamp in the memory menu. This stored file can be recalled and used later to show additional features.

To verify the setup with the support ring over a flaw

For this subprocedure, the support ring is moved directly over a flaw in order to verify that the flaw is still visible with the **MIX** display.

1. Slide the o-rings on the tube to allow movement of the support ring. Move the support ring over the flaw and place the o-rings against the support ring to keep it in position (see Figure 5-175 on page 252).

Slide the o-rings and support ring until they are centered over the flaw (indicated with red arrow).

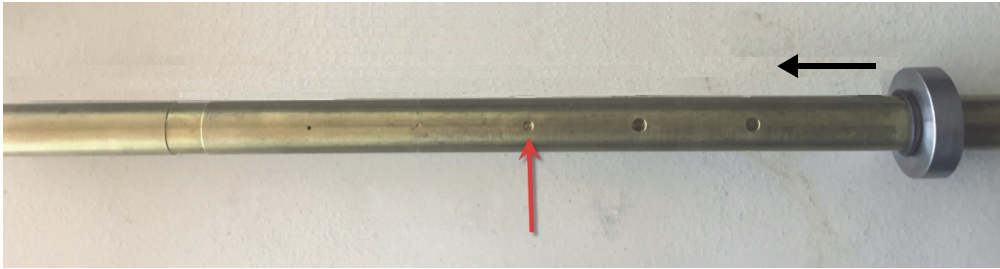

Figure 5-175 Moving the support ring

2. Place the probe in a defect-free area (see Figure 5-176 on page 252), and then press the NULL foot switch.

Null the probe here (previous position of the support ring).



Figure 5-176 The null position after moving the support ring

3. Scan the tube for defects (see Figure 5-177 on page 253).

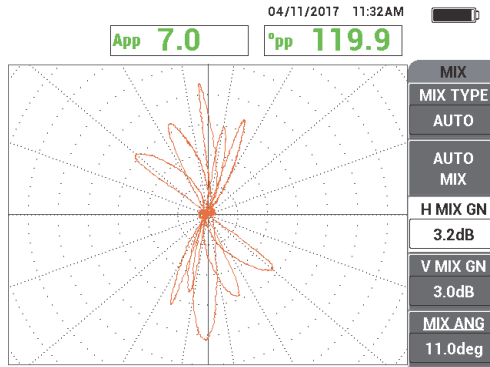

Figure 5-177 The tube scan result after moving the support ring (MIX)

4. Place the probe in a defect-free area (see Figure 5-176 on page 252).
5. Press the DISP menu key (□), followed by **CHANNEL** (B key), and then rotate the knob until **FREQ 1** is displayed.
6. Press the NULL foot switch, and scan the tube.

It should be easy to spot the flaw under the support ring (see Figure 5-178 on page 253).

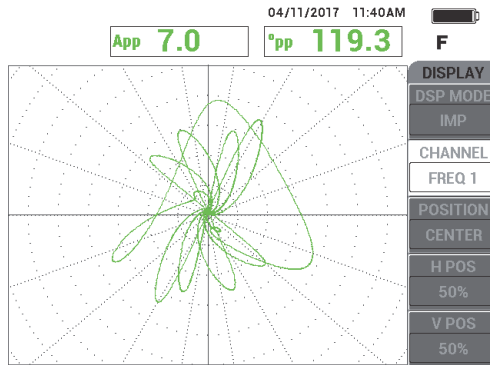



Figure 5-178 The scan result with the support ring over the flaw in FREQ 1

5.4.1.2 Displaying Reference Signals

The NORTEC 600 lets you add reference-signal displays (reference images) to the live signal acquisition screen. This helps you to identify the flaw type that is displayed (acquired) on the screen.

To display reference signals

1. Move the support ring to its original position (the position before you verified the setup with support ring over a flaw).
2. Press the MEM menu key () and then use the knob to select (highlight) the file stored earlier, and press **RECALL** (B key).
3. Place the probe in a defect-free area near the tube's support ring, and then press the NULL foot switch.
4. Scan the tube.
5. Press and hold the REF SAVE () key until you hear a beep.

NOTE

The REF SAVE () key can be used in the following two ways:

- a) Quickly press the key once to save a setup in memory.
- b) Press and hold the key until you hear a beep to store the current image as a reference image, in a color complementary to the live signal.

-
6. Press the ERASE key () or the ERASE foot switch.
The signals captured in the step above are used to create a reference image.
 7. Place the probe in a defect-free area near the tube's support ring, and then press the NULL foot switch.
 8. Scan the tube.
The live signal display should be nearly identical to the reference image (see Figure 5-179 on page 255).

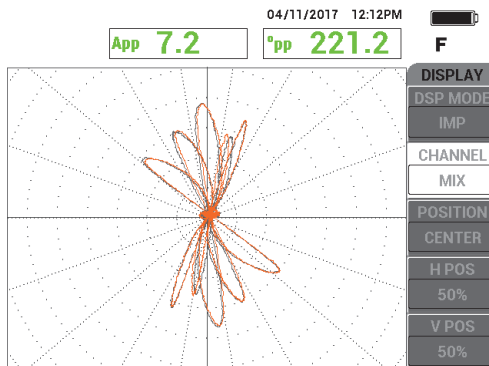



Figure 5-179 Tube scan display with reference image (gray) and live signal (orange)

5.4.1.3 Using the ALL-IN-1 (Strip Chart) Display

The **ALL-IN-1** function can be used with frequency 2 to create a “strip chart” type of display that represents the tube inspection history. This section’s setup uses settings from the previous section. Alternatively, the saved file can be recalled from memory.

To use the ALL-IN-1 display

1. Press **DISP MODE** (A key), and rotate the knob until **ALL-IN-1** is displayed.
2. Press the DISP menu key () twice to display the **FRQ2 DSP** menu (see Figure 5-180 on page 256).

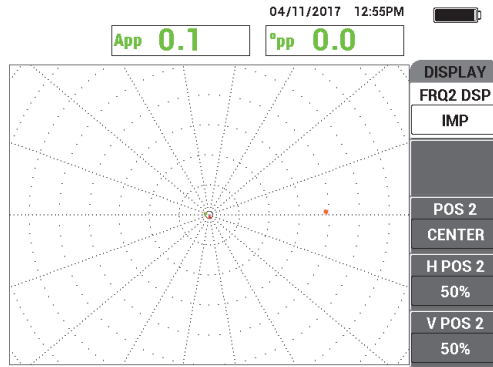

Figure 5-180 The FRQ2 DSP menu

3. Press **V POS 2** (E key), and rotate the knob until **20%** is displayed.
4. Press **FRQ2 DSP** (A key), and rotate the knob until **AUTO Y** is displayed.
5. Place the probe in a defect-free area near the tube's support ring, and then press the NULL foot switch.
6. Scan the tube.

The scan results are shown in Figure 5-181 on page 256.

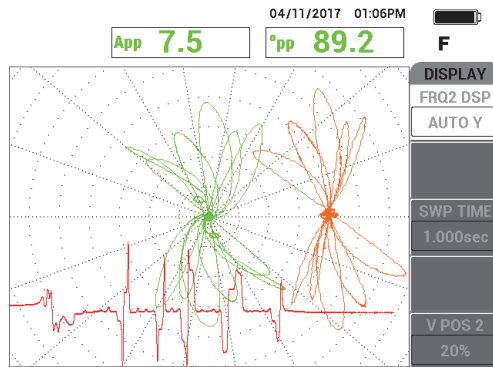

Figure 5-181 The tube scan with the ALL-IN-1 display

5.4.2 ECT Erosion and Corrosion — NORTEC 600D Model

In this application, an absolute configuration is used to identify volumetric or gradual defects such as erosion and corrosion in nonferromagnetic alloys. An example of an absolute signal response is shown in Figure 5-182 on page 257. (For a general explanation of ECT technology, see “ECT Pitting, Wear, and Cracks — NORTEC 600D Model” on page 236.)



Figure 5-182 An example of an ECT absolute signal response

This application uses inspection materials similar to the example illustrated in Figure 5-135 on page 222 (in the application “Inspecting Heat Exchanger Tubing Using Dual Frequency — NORTEC 600D Model” on page 221).

The following products are used in this procedure:

- Eddy current bobbin probe for heat exchanger tubing: absolute/differential, 14.8 mm (0.583 in.) diameter, 15 kHz center frequency, 20 m (65.6 ft) cable; P/N: TEA-148-015-N05 [U8282109]
- Differential and absolute eddy current probe adapter; P/N: CBAS-10818-0001 [Q7670051]
- Admiralty brass calibration standard: OD 19 mm (0.75 in.), WT (wall thickness) 1.65 mm (0.065 in.); P/N: CT02-001-D16 [U8779241]
- Convenient, highly recommended items (however, not mandatory): foot switch (P/N: 9522333 [Q7670007]), foot switch armored cable (P/N: 9122404 [Q7670008]), and foot switch adapter (P/N: 9522336 [Q2500083])

To set the initial NORTEC 600 configuration

1. Connect the adapter, probe, and foot-switch adapter cable to the PROBE connector on the NORTEC 600.

2. Select **CONTINUE** (press the A key), and then use the knob to select **ECT Erosion and Corrosion**, and press ✓ to accept (see Figure 5-183 on page 258).

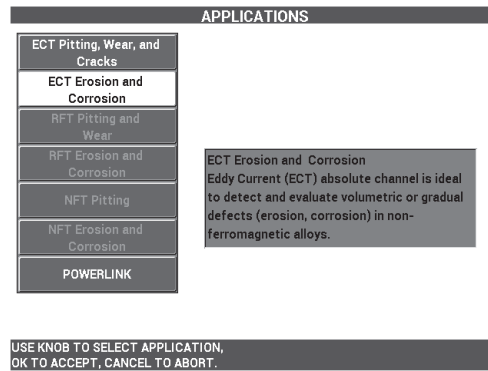

Figure 5-183 The ECT Erosion and Corrosion application

To calibrate the signals

1. Press **FREQ** (frequency, A key), and use the knob to select **5 kHz**.
2. Place the probe in a defect-free area of the calibration standard near the 10 % ID flaw, and then press the NULL foot switch.
3. Slowly scan the tube until the 10 % ID and 20 % OD flaws are displayed. When the groove signals are visible on the NORTEC 600 screen, press the FREEZE key (❄) [see Figure 5-184 on page 259].

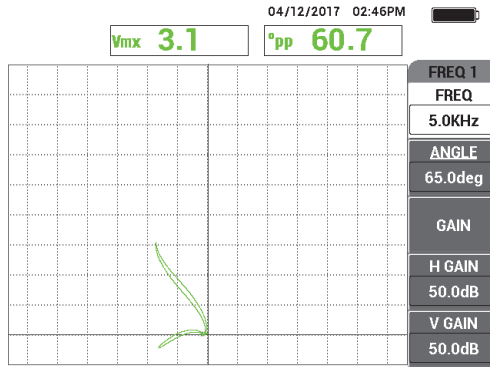



Figure 5-184 The scan of the two grooves

4. Press the ANGLE key () , and then rotate the signal until the OD groove signal reaches a phase of approximately 10° (see Figure 5-185 on page 259).

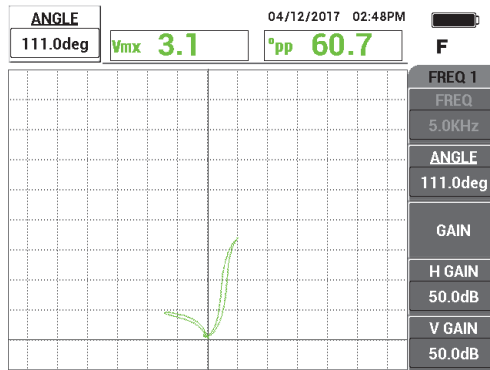



Figure 5-185 Adjusting the signal phase

5. Press the GAIN key (**dB**), and then increase the gain until the hole signal reaches approximately 4 vertical divisions in height. Press the FREEZE key () to enable signal acquisition (see Figure 5-186 on page 260).

IMPORTANT

Always use combined horizontal and vertical gain (**H/V GAIN**).

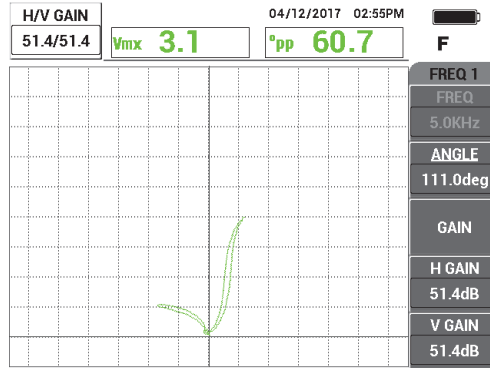



Figure 5-186 Adjusting the gain

6. Place the probe in a defect-free area of the calibration standard near the 10 % ID flaw, and then press the NULL foot switch.
7. Scan the 10 % ID and 20 % OD flaws.
8. Press and hold the REF SAVE () key until you hear a beep, and then press the ERASE key () or ERASE foot switch.

This provides a reference image in a complimentary color on the screen for reference purposes (see Figure 5-187 on page 261).

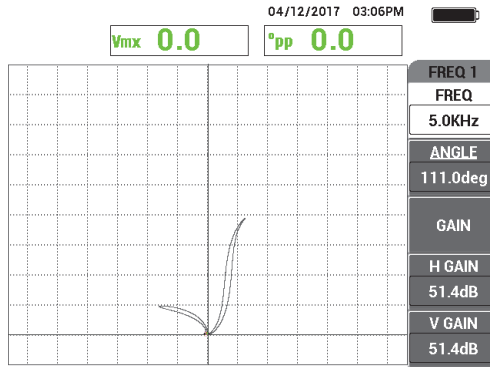

Figure 5-187 The 10 % ID and 20 % OD flaws set as a reference image

9. Place the probe in a defect-free area of the calibration standard near the 10 % ID flaw, and then press the NULL foot switch.
10. Press the FULL NEXT key (→).
11. Scan the entire length of the tubing.

The scan result is shown in Figure 5-188 on page 261.

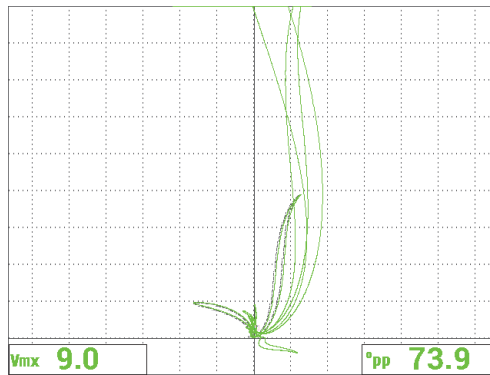

Figure 5-188 The tube scan result

5.4.3 RFT Pitting and Wear — NORTEC 600D Model

This remote-field testing (RFT) application uses a differential configuration to identify small localized defects such as pitting and wear in ferromagnetic tubing.

Remote-field testing (RFT) probes can successfully inspect ferromagnetic tubing such as carbon steel or ferritic stainless steel. Their high sensitivity enables detection and measurement of volumetric defects caused by erosion, corrosion, wear, and baffle cuts.

RFT is a thru-wall transmission technique. The remote-field probe is a low-frequency variant of the exciter (driver)-pickup eddy current probe, which is characterized by an exciter-to-pickup distance of at least 2.5 to 3 times the tube OD. This distance is essential and critical for the pickup coils to be able to sense the “remote” magnetic field rather than the “direct” field.

The basic probe is made of one exciter coil and two pickup coils (see Figure 5-189 on page 263). There are two magnetic fields present: the **direct field** in the vicinity of the exciter coil is rapidly attenuated with distance, while the **indirect field** is diffused outward through the tube wall. The indirect field then propagates along the tube axis, before being rediffused back through the tube wall. The zone in which the indirect field is dominant is called the remote field. This zone is present at a distance greater than two tube diameters.

All remote-field probes have their pickup coils set to 2.5 to 3 times the tube OD to ensure that only the indirect field is sensed (“picked up”) by the coils. All Evident RFT probes have a set of circumferential pickup coils that can be operated simultaneously in absolute and differential mode.

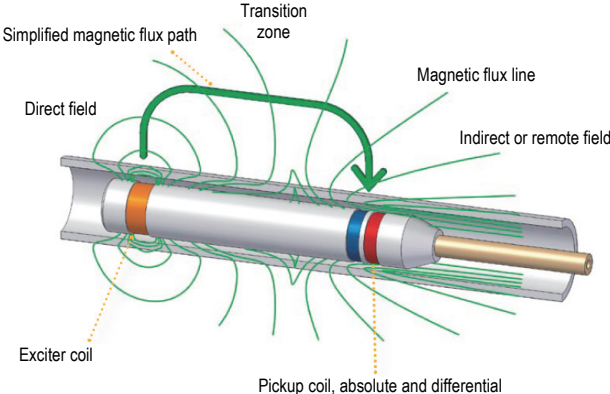

Figure 5-189 An RFT probe

This application uses a probe adapter configured for differential mode. The differential configuration subtracts the signals obtained by both receiving coils and, as such, is ideal for detecting smaller discontinuities such as pitting, but also shorter discontinuities such as wear under a support (see Figure 5-190 on page 263). The differential configuration, however, cannot be used to detect longer or gradual discontinuities for the simple reason that the discontinuity signal is “subtracted” (diminished) and therefore not useful. To detect longer or gradual discontinuities, absolute mode must be used.

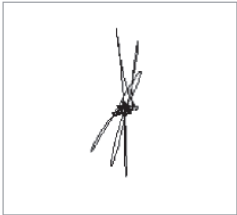

Figure 5-190 An example of an RFT differential signal response

Dual exciter probes (such as TRX series Evident probes) are recommended for differential configuration because these types of probes provide a clearer and cleaner response to smaller, localized discontinuities (see Figure 5-191 on page 264). Single exciter probes (such as TRS series Evident probes) can also be used; however, they are generally outperformed by dual exciter probes for pitting detection.

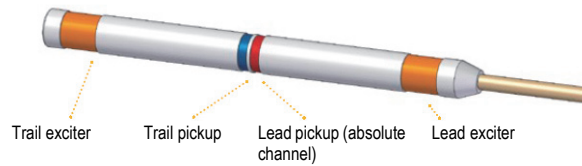

Figure 5-191 A dual exciter probe

Additionally, dual exciter probes provide an equal response on both sides of the support because there is always one exciter providing energy to allow detection (see Figure 5-192 on page 264).

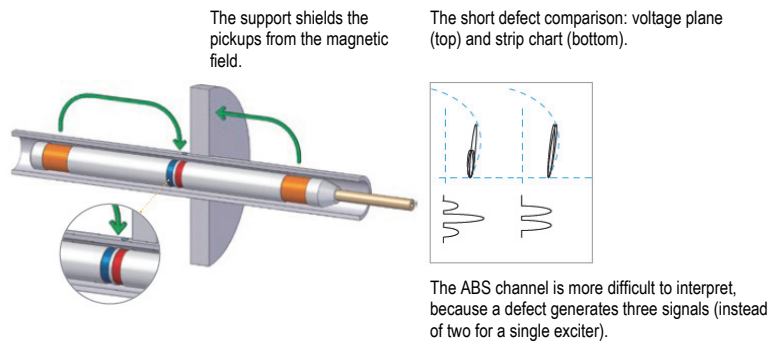

Figure 5-192 Equal response on both sides of a support with a dual exciter probe

The use of dual frequency and mixing can highly enhance the inspection results. The main enhancement made by a **MIX** channel in RFT is the reduced minimum distance from the support at which a defect can be reliably detected. With a typical (single frequency) configuration, a corrosion pit can be detected from a distance equivalent to about one tube OD (outside diameter) thickness away from the support. When using a properly calibrated **MIX** channel, this distance is eliminated and pits can be detected even when they are partially covered by the support.

5.4.3.1 Using the Application

This application uses inspection materials similar to the example illustrated in Figure 5-135 on page 222 (in the application “Inspecting Heat Exchanger Tubing Using Dual Frequency – NORTEC 600D Model” on page 221).

The following products are used in this procedure:

- Probe; P/N: TRX-130-300-N20 [U8280123]
- Differential and absolute remote-field probe adapter; P/N: CBAS-10821-0001 [Q7670054]
- Demonstration calibration standard (P/N: MESX0397 [Q7800046]) and large support for calibration standard (P/N: MESX0400 [Q7800049]).
- Convenient, highly recommended items (however, not mandatory): foot switch (P/N: 9522333 [Q7670007]), foot switch armored cable (P/N: 9122404 [Q7670008]), and foot switch adapter (P/N: 9522336 [Q2500083])

To set the initial NORTEC 600 configuration

1. Connect the adapter, probe, and foot-switch adapter cable to the PROBE connector on the NORTEC 600.
2. Select **CONTINUE** (press the A key), and then use the knob to select **RFT Pitting and Wear**, and press ✓ to accept (see Figure 5-193 on page 265).

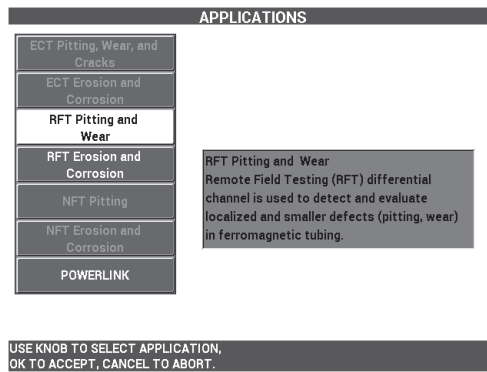

Figure 5-193 The RFT Pitting and Wear application

To calibrate frequency 1

1. Loosen the set screw on the support ring, slide the support ring over the four shallow pits near the tube end, and then tighten the set screw.
2. Place the probe in a defect-free area of the calibration standard near the thru-wall flaw, and then press the NULL foot switch.
3. Slowly scan the tube until the thru-wall flaw is displayed, and then press the FREEZE key (❄) [see Figure 5-194 on page 266].

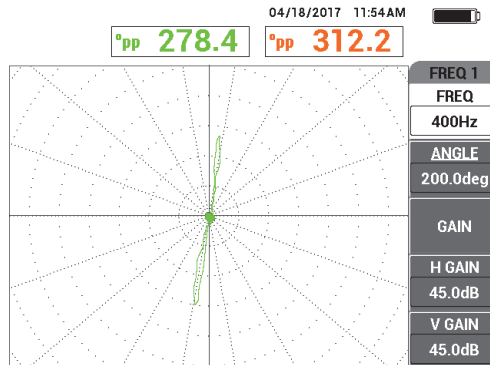

Figure 5-194 The scan of the thru-wall hole

4. Press the ANGLE key (◁), and then rotate the signal until the thru-wall signal is vertical on the instrument screen (see Figure 5-195 on page 267).

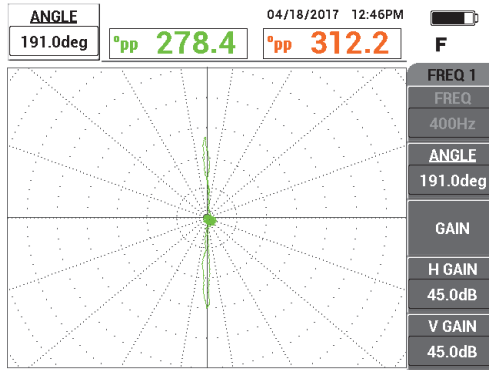

Figure 5-195 Adjusting the signal phase

- Press the GAIN key (**dB**), and then increase the gain until the hole signal reaches approximately 4 to 6 vertical divisions in height. Press the FREEZE key (❄) to enable signal acquisition (see Figure 5-196 on page 267).

IMPORTANT

Always use combined horizontal and vertical gain (**H/V GAIN**).

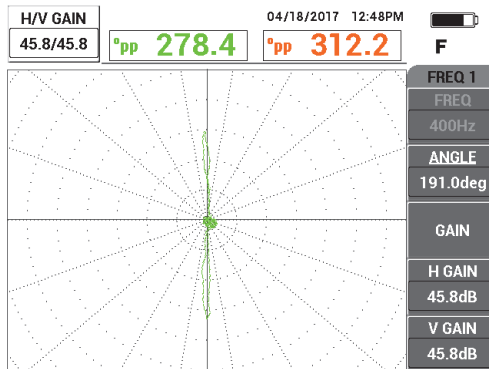

Figure 5-196 Adjusting the gain

- Place the probe in a defect-free area of the calibration standard near the thru-wall flaw, and then press the NULL foot switch.
- Slowly scan the entire length of the tube, and press the FREEZE key (❄️) when done (see Figure 5-197 on page 268).

IMPORTANT

Remote-field testing (RFT) requires a slow inspection speed, and practice. Scan the tube at several inspection speeds and note how the signal varies until you are comfortable with the scan rate.

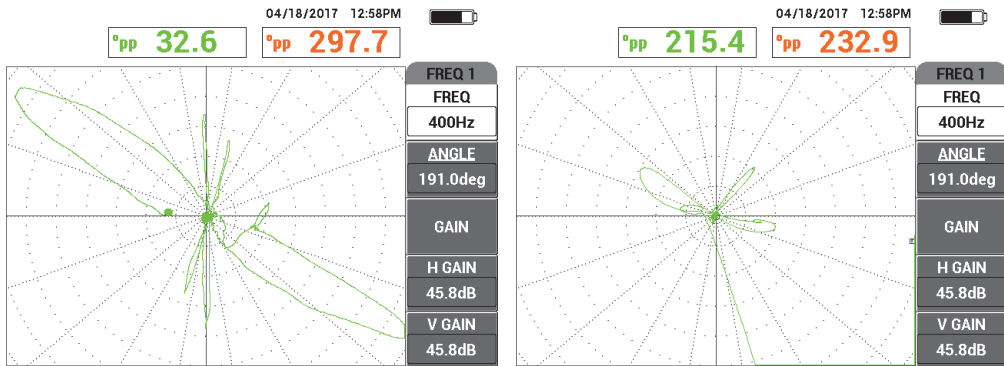

Figure 5-197 A slow scan rate (optimal signal, *left*) and a fast scan rate (loss of signal, *right*)

- Adjust the support ring signal so that it is not being clipped by the screen (8 to 9 major divisions) [see Figure 5-198 on page 269].

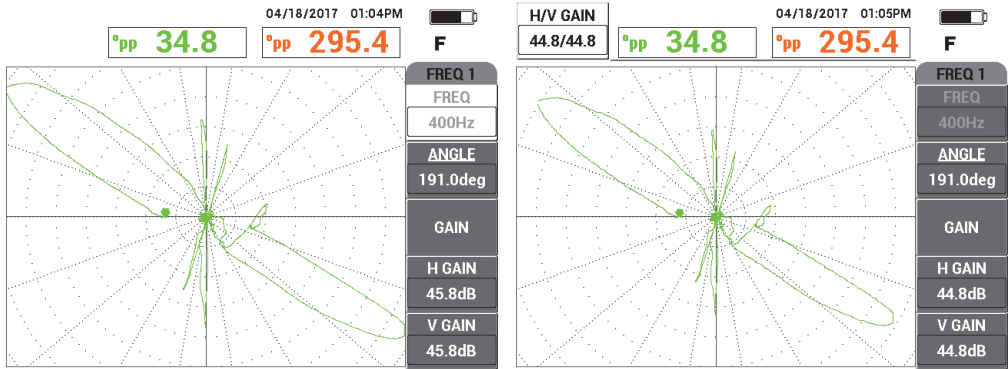

Figure 5-198 The support ring's signal clipped (*left*) and with adjusted gain (*right*)

To calibrate frequency 2

1. Press the MAIN FILTER menu key (✂), followed by **FREQ 2** (A key), and then rotate the knob until **200 Hz** or less is displayed.
2. Press the DISP menu key (□), followed by **CHANNEL** (B key), and then rotate the knob until **FREQ 2** is displayed.
3. Place the probe in a defect-free area of the calibration standard near the thru-wall flaw, and then press the NULL foot switch.
4. Scan the entire length of the tube, and press the FREEZE key (❄) when done (see Figure 5-199 on page 270).

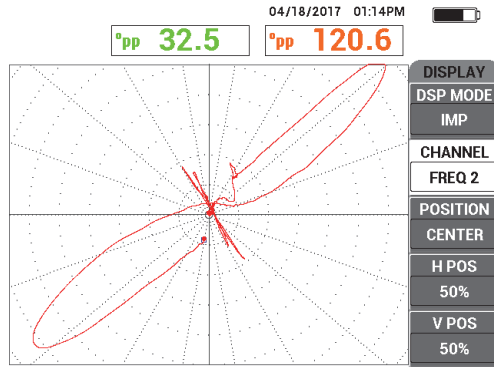



Figure 5-199 The scan of the entire length of the tube

5. Press the ANGLE key () and then rotate the signal until the thru-wall signal is vertical on the instrument screen (see Figure 5-200 on page 270).

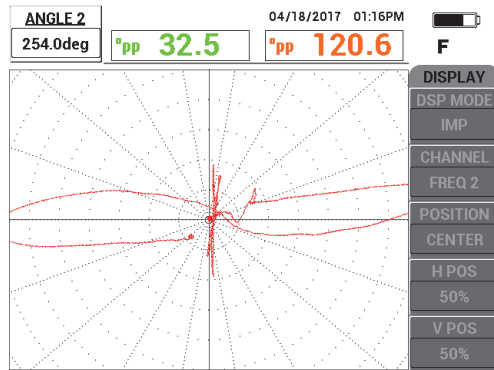

Figure 5-200 Angle adjustment in FREQ 2

6. Adjust the support ring signal so that it is not being clipped by the screen (8 to 9 major divisions) [see Figure 5-201 on page 271].

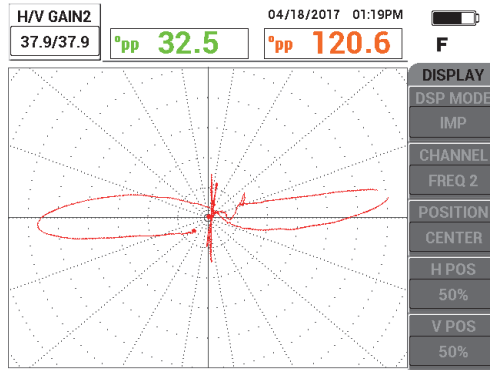

Figure 5-201 GAIN adjustment in FREQ 2

7. Press the FREEZE key (❄) to enable signal acquisition.
8. Place the probe in a defect-free area of the calibration standard near the thru-wall flaw, and then press the NULL foot switch.
9. Scan the entire length of the tube, and verify that the thru-wall flaw is vertical and the support ring signal is not clipped. Adjust as required (see Figure 5-202 on page 271).

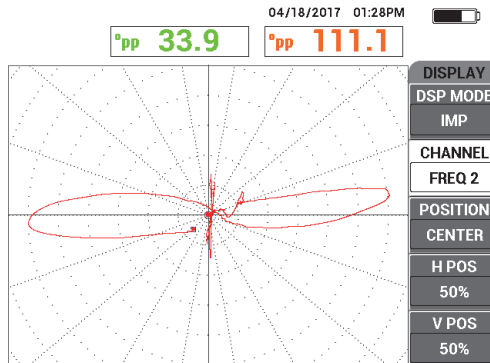

Figure 5-202 Verification signal in FREQ 2

To calibrate using MIX

1. Press **CHANNEL** (B key), and then rotate the knob until **MIX** is displayed.
2. Place the probe in a defect-free area of the calibration standard near the thru-wall flaw, and then press the **NULL** foot switch.
3. Scan the thru-wall flaw, and press the **FREEZE** key (❄️) when done.
4. Press the **MAIN FILTER** menu key (🌀) three times.
The **MIX** menu appears (see Figure 5-203 on page 272).

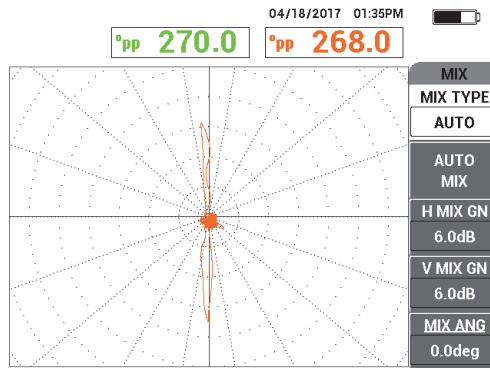

Figure 5-203 The MIX menu

5. Press **MIX ANG** (mix angle, E key) and, if necessary, adjust the thru-wall flaw signal until it is vertical.
6. Press the **FREEZE** key (❄️) to enable signal acquisition.
7. Press **AUTO MIX** (B key), and then scan the remainder of the tube.

IMPORTANT

The **AUTO MIX** function is automatic and records the signal for 5 seconds after **AUTO MIX** (B key) has been pressed.

8. Verify that the **AUTO MIX** signal has been acquired:

- ◆ Place the probe in a defect-free area of the calibration standard near the thru-wall flaw, press the NULL foot switch, and scan the entire length of tube. The large indication of the support ring should be minimized, as shown in Figure 5-204 on page 273.

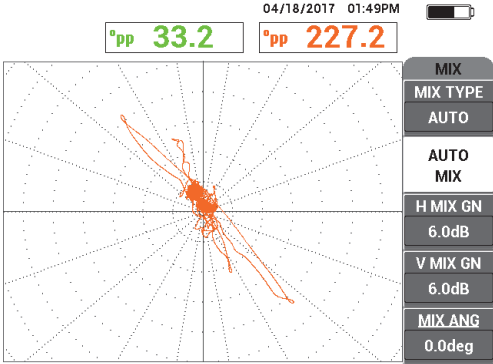

Figure 5-204 The scan of entire tube length after AUTO MIX

9. Press the FREEZE key (❄), followed by MIX ANG (mix angle, E key), and then rotate the knob until the larger thru-wall signal is vertical (see Figure 5-205 on page 274).

NOTE

The direct function keys on the left side of the instrument screen do not function while the MIX menu is being used.

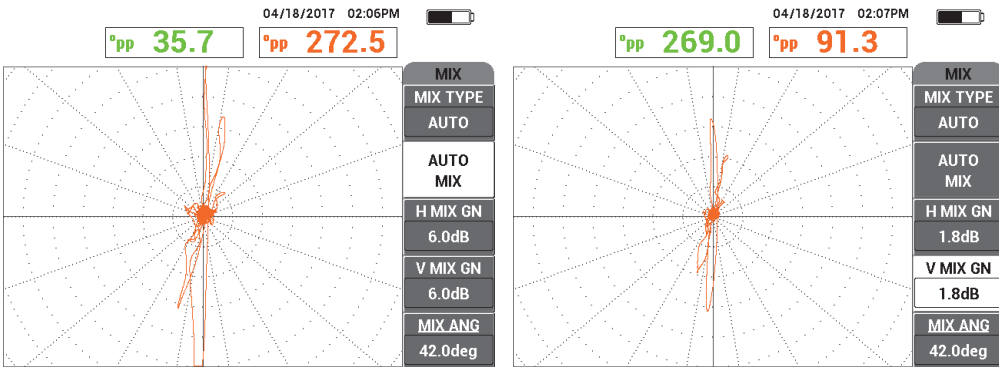

Figure 5-205 The signal after AUTO MIX (*left*); with angle/gain adjustment (*right*)

- Adjust **H MIX GN** (horizontal MIX gain, C key) and **V MIX GN** (vertical MIX gain, D key) until the signal is approximately 6 major divisions long.

IMPORTANT

Combined horizontal and vertical gain adjustment is not available while using the **MIX** menu. Adjustments to horizontal and vertical gain must be made separately and equally.

- Press the **FREEZE** key (❄) to enable signal acquisition.
- Place the probe in a defect-free area near the thru-wall flaw, and then press the **NULL** foot switch.
- Scan the tube for defects to verify the **MIX** signal.

5.4.3.2 Enhancing the Signal with the LO PASS Filter

You can use the **LO PASS** filter to clean your signal and improve your display.

To enhance the signal with the LO PASS filter

- Press the **MAIN FILTER** menu key (⚙), followed by **LO PASS** (B key), and then rotate the knob until **10 Hz** is displayed.

2. Place the probe in a defect-free area near the thru-wall flaw, and then press the NULL foot switch.
3. Scan the tube for defects (see Figure 5-206 on page 275).

IMPORTANT

When lowering the **LO PASS** filter, you must also lower the scan rate by the same amount as applied to the filter.

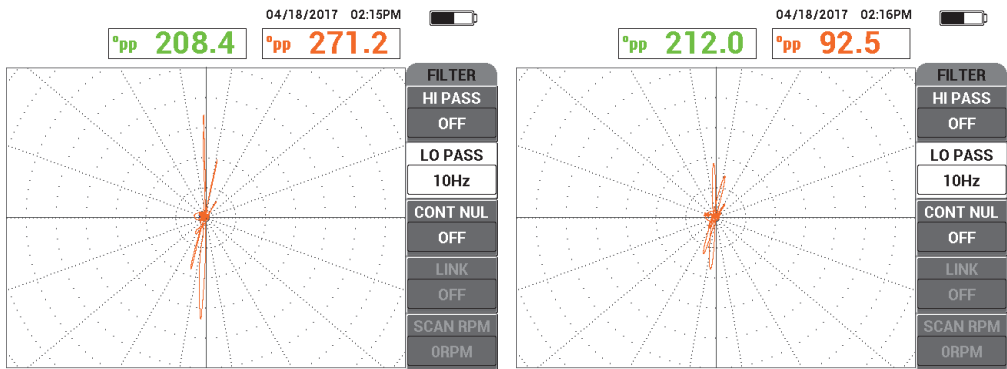



Figure 5-206 A scan with 10 Hz LO PASS filter (*left*); with scan rate too fast (*right*)

5.4.3.3 Using the ALL-IN-1 Display

This section shows you how to use **ALL-IN-1** to display the small cluster of four corrosion pits under the support ring and the corrosion pit near (but not underneath) the support ring.

To use the ALL-IN-1 display

1. Press the DISP menu key () , followed by **DSP MODE** (display mode, A key), and then rotate the knob until **ALL-IN-1** is displayed.
2. Press the DISP menu key () twice, followed by **FRQ2 DSP** (frequency 2 display, A key), and then rotate the knob until **AUTO Y** is displayed.

3. Press **V POS 2** (vertical position 2, E key), and then rotate the knob until **20 %** is displayed.
4. Place the probe in a defect-free area near the thru-wall flaw, and then press the NULL foot switch.
5. Scan the tube for defects.

The resulting scan displays the following signals (see Figure 5-207 on page 276):

- a) Frequency 1 signal (center screen)
- b) **MIX** signal (center-right screen)
- c) Frequency 2 as a strip chart (bottom screen)

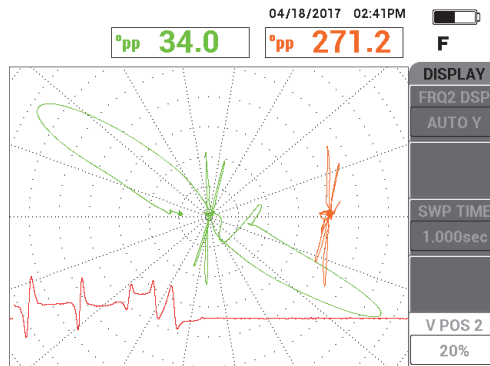

Figure 5-207 ALL-IN-1 display of cluster of 4 corrosion pits under support ring

6. Loosen the thumb screw on the support ring, and then slide the support ring to within 3.2 mm (0.125 in.) of the **75 %** corrosion pit.
7. Place the probe in a defect-free area near the thru-wall flaw, and then press the NULL foot switch.
8. Scan the tube for defects.

The scan result is shown in Figure 5-208 on page 277.

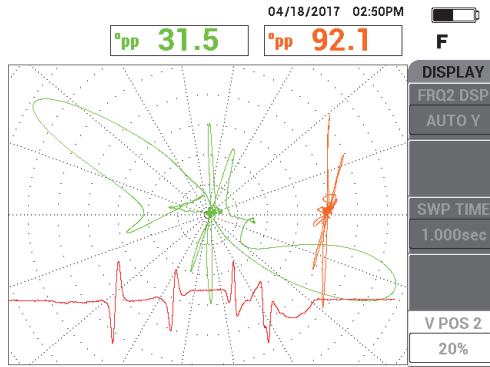

Figure 5-208 ALL-IN-1 display with support ring within 3.2 mm (0.125 in.) of 75 % corrosion pit

5.4.4 RFT Erosion and Corrosion — NORTEC 600D Model

This remote-field testing (RFT) application uses an absolute configuration to identify volumetric or gradual defects such as erosion and corrosion in ferromagnetic tubing (see Figure 5-209 on page 277).

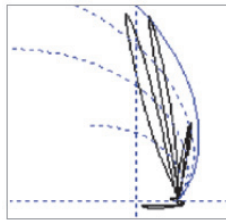

Figure 5-209 An example of an RFT absolute signal response

The use of single exciter probes is recommended for the absolute configuration (such as TRS series Evident probes) because they provide easier-to-interpret signals as well as a sharper response to short but significant defects (see Figure 5-210 on page 278 and Figure 5-211 on page 278). Alternatively, dual exciter probes (such as Evident TRX series probes) can also be used. However, their larger and triple signal response is typically more challenging to analyze when you are trying to detect erosion and corrosion defects.

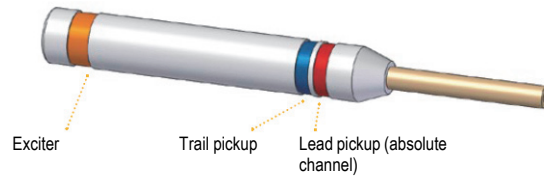

Figure 5-210 A single exciter probe

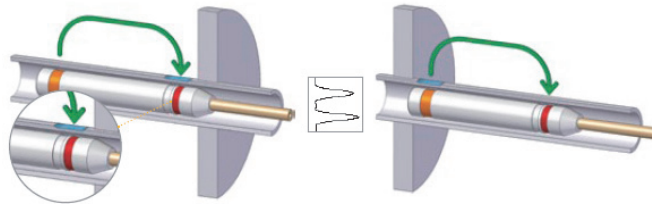

Figure 5-211 A large defect detected on both sides of a support using the absolute (ABS) channel

5.4.4.1 Using the Application

This application uses inspection materials similar to the example illustrated in Figure 5-135 on page 222 (in the application “Inspecting Heat Exchanger Tubing Using Dual Frequency – NORTEC 600D Model” on page 221).

The following products are used in this procedure:

- Probe (P/N: TRS-130-300-N20 [U8280143])
- Differential and absolute remote-field probe adapter; P/N: CBAS-10821-0001 [Q7670054]
- Demonstration calibration standard; P/N: MESX0398 [Q7800054]
- Convenient, highly recommended items (however, not mandatory): foot switch (P/N: 9522333 [Q7670007]), foot switch armored cable (P/N: 9122404 [Q7670008]), and foot switch adapter (P/N: 9522336 [Q2500083])

To set the initial NORTEC 600 configuration

1. Connect the adapter, probe, and foot-switch adapter cable to the PROBE connector on the NORTEC 600.
2. Select **CONTINUE** (press the A key), and then use the knob to select **RFT Erosion and Corrosion**, and press ✓ to accept (see Figure 5-212 on page 279).

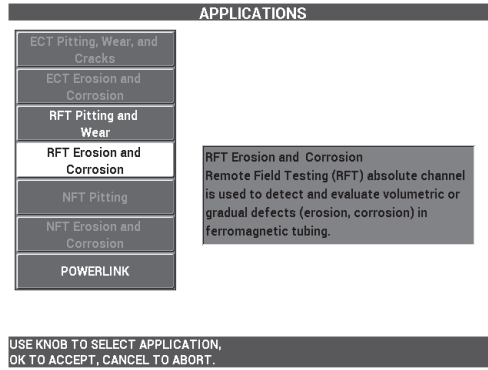

Figure 5-212 The RFT Erosion and Corrosion application

To calibrate the signals

1. Place the probe in a defect-free area of the calibration standard near the 10 % ID flaw, and then press the NULL foot switch.
2. Slowly scan the tube until the 40 % ID and 60 % OD flaws are displayed. When the groove signals are visible on the NORTEC 600 screen, press the FREEZE key (❄) [see Figure 5-213 on page 280].

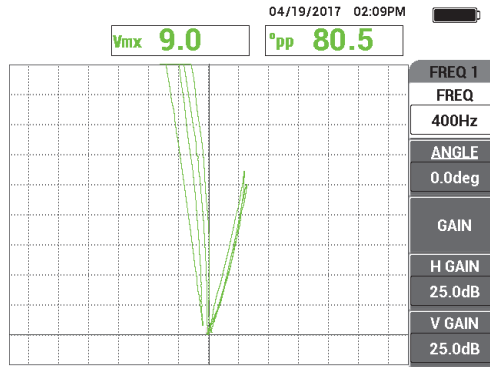



Figure 5-213 The scan of the two grooves

3. Press the ANGLE key () , and then rotate the signal until the OD grooves are split by the vertical cross-hair (see Figure 5-214 on page 280).

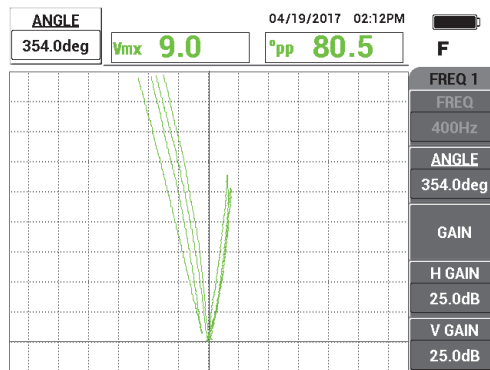

Figure 5-214 Adjusting the signal phase

4. Press the GAIN key (**dB**), and then decrease the gain until the 60 % wall-loss flaw signal reaches approximately 90 % of vertical height.

IMPORTANT

Always use combined horizontal and vertical gain (**H/V GAIN**).

5. Press the FREEZE key (❄) to enable signal acquisition.
6. Rescan the 60 % wall-loss flaw to verify the calibration, and adjust the **GAIN** as required.
7. Adjust the **ANGLE** as required (see Figure 5-215 on page 281).

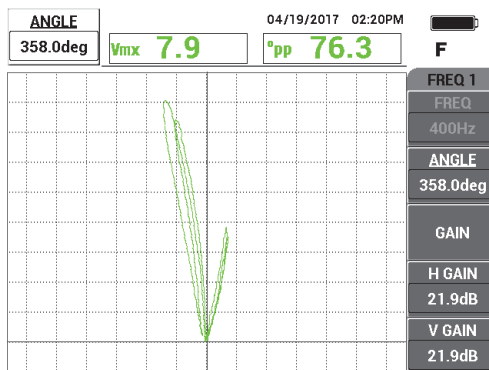

Figure 5-215 Adjusting the gain and angle

8. Place the probe in a defect-free area of the calibration standard near the 40 % OD flaw, and then press the NULL foot switch.
9. Scan the 40 % OD and 60 % OD flaws.
10. Press and hold the REF SAVE (REF) key until you hear a beep, and then press the ERASE key (E) or ERASE foot switch.

This will provide a reference image in a complimentary color on the screen for reference purposes (see Figure 5-216 on page 282).

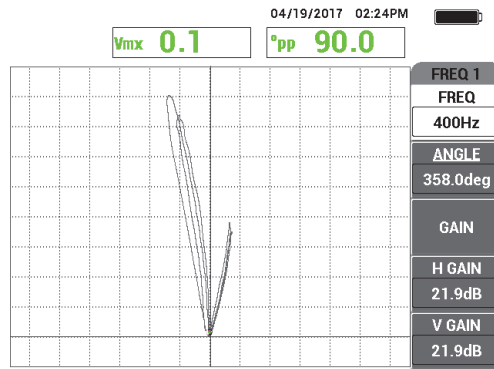



Figure 5-216 The 40 % OD and 60 % OD flaws set as a reference image

11. Place the probe in a defect-free area of the calibration standard near the 20 % OD flaw, and then press the NULL foot switch.
12. Press the FULL NEXT key ().
13. Scan the entire length of the tube.

The scan result is shown in Figure 5-217 on page 282.

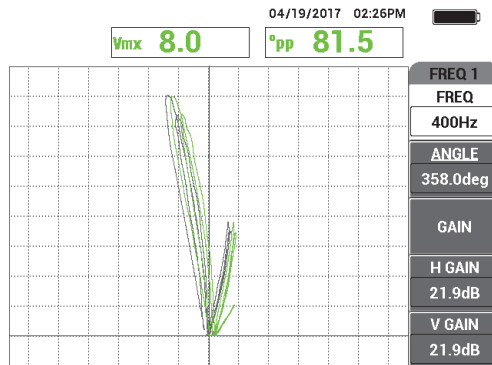





Figure 5-217 The scan of the entire length of the tube

5.4.4.2 Using the Overlay Display

The remote-field curve is an alternative overlay display available on the NORTEC 600. To use this display, you must save a calibration setup and then rename the calibration setup file after it has been created.

To use the overlay display

1. Perform and then save a calibration by pressing the REF SAVE ( ^{REF}) key.
2. Press the MEM menu key ( ^{MEM}).
3. Use the knob to select the calibration file you just created.
By default, the NORTEC 600 saves the file with a time/date stamp.
4. Press **EDIT** (C key).
5. Use the text editor to rename the file as follows: **RFT_CURVE** (see Figure 5-218 on page 283). (Use the knob to select characters and the FULL NEXT key () to confirm each character.)

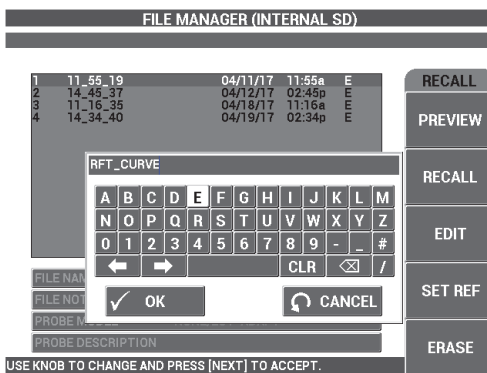



Figure 5-218 Renaming the file

6. Press  to accept the file name.
7. Press the ADV SETUP menu key () followed by **APL SELECT** (application select, A key).

8. Use the knob to select the **RFT Erosion and Corrosion** application, and press ✓ to accept.

The overlay is displayed with the previous calibration settings on the screen (see Figure 5-219 on page 284).

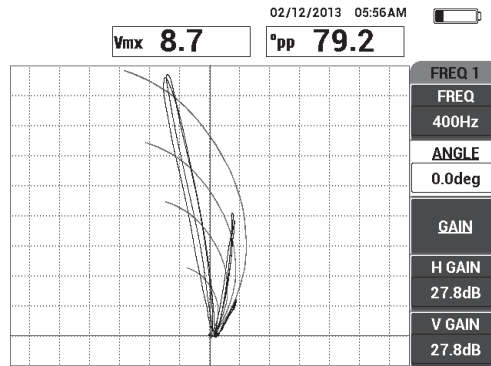

Figure 5-219 The overlay (background voltage plane for absolute RFT signal analysis) and the scan of the tube

5.4.4.3 Optimizing the Frequency

In remote-field testing, the optimal frequency is the one that gives you 1 degree per percent of loss. You can check your calibration to ensure that the optimal frequency has been chosen.

In the example calibration shown in Figure 5-220 on page 285, the angle peak-to-peak ($^{\circ}\text{pp}$) reading of the 60 % OD flaw is subtracted from the angle peak-to-peak ($^{\circ}\text{pp}$) reading of the 40 % OD flaw:

$$105.1^{\circ} - 84.6^{\circ} = 20.5^{\circ}$$

This 20.5° value is close to the (60 – 40 = 20 %) loss value and therefore provides the desired ratio of 1 degree per percent of loss.

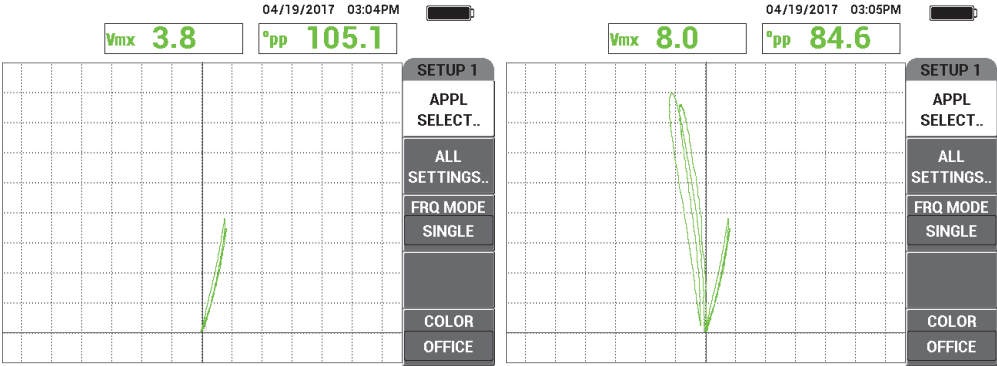

Figure 5-220 The readings for 40 % OD loss (left) and 60 % OD loss (right)

5.4.5 NFT Pitting (Differential) — NORTEC 600D Model

This near-field testing (NFT) application uses a differential configuration to detect internal pitting in finned air-cooler tubing (also referred to as “fin-fan”) [see Figure 5-221 on page 285].



Figure 5-221 A finned air-cooler tube (fin-fan)

The near-field testing (NFT) eddy current technology is a rapid and inexpensive inspection solution designed specifically for ID defect detection in carbon steel finned tubes (see Figure 5-222 on page 286). NFT probes reduce inspection cost and improve ease-of-use.

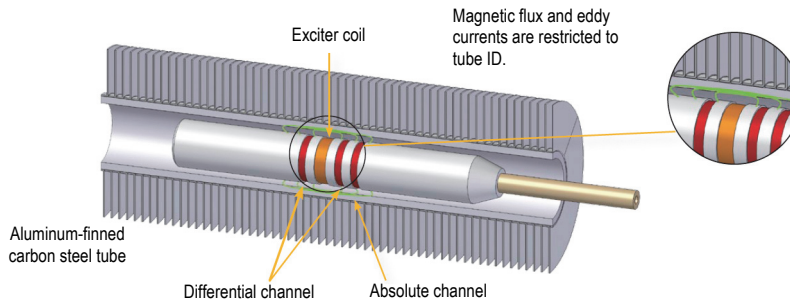

Figure 5-222 The NFT inspection technology

Near-field probes are an excellent alternative to IRIS (internal rotating inspection [ultrasonic] system) and magnetic flux leakage (MFL) probes. NFT technology, which is based on a simple eddy current exciter (driver)-pickup design, produces signals that are very easy to analyze. NFT probes also allow a fast pulling speed (up to 1 m/s). In addition, there is no magnet, which means probe pushing and pulling is easier.

This application uses a probe adapter operating in differential mode (see Figure 5-223 on page 286). The differential configuration subtracts the signals obtained by both receiving coils and, as such, is ideal for detecting smaller discontinuities such as pitting (see Figure 5-224 on page 287). The differential configuration, however, cannot be used to detect longer or gradual discontinuities for the simple reason that the discontinuity signal is “subtracted” (diminished) and therefore not useful. To detect longer or gradual discontinuities, absolute mode (with appropriate adapter) must be used.



Figure 5-223 The differential exciter-pickup configuration

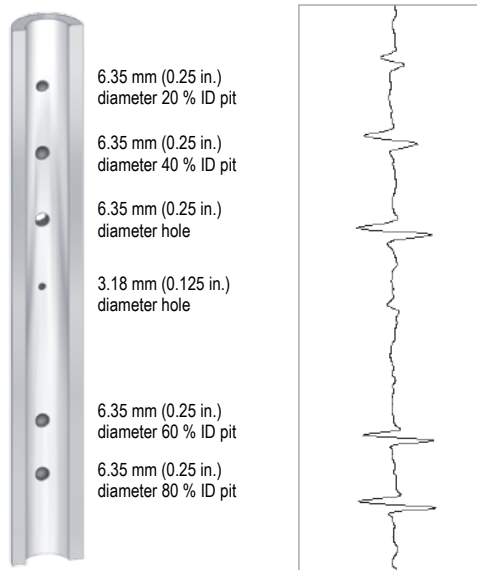

Figure 5-224 Example NFT signal responses (differential configuration)

This application uses inspection materials similar to the example illustrated in Figure 5-135 on page 222 (in the application “Inspecting Heat Exchanger Tubing Using Dual Frequency — NORTEC 600D Model” on page 221).

The following products are used in this procedure:

- Eddy current probe; P/N: TRD-170-300-N05 [Q2800326]
- Differential near-field probe adapter (P/N: CBAS-10819-0001 [Q7670052])
- Calibration standard; P/N: CT45-009-F12 [Q7800048]
- Convenient, highly recommended items (however, not mandatory): foot switch (P/N: 9522333 [Q7670007]), foot switch armored cable (P/N: 9122404 [Q7670008]), and foot switch adapter (P/N: 9522336 [Q2500083])

To set the initial NORTEC 600 configuration

1. Connect the adapter, probe, and foot-switch adapter cable to the PROBE connector on the NORTEC 600.

2. Select **CONTINUE** (press the A key) to open the application selection menu, and then use the knob to select **NFT Pitting**, and press ✓ to accept (see Figure 5-225 on page 288).

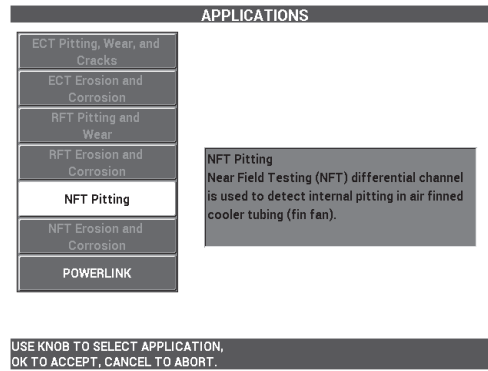

Figure 5-225 The NFT Pitting application

To calibrate the signals

1. Place the probe in a defect-free area of the calibration standard near the thru-wall hole, and then press the NULL foot switch.
2. Slowly scan the thru-wall hole, pressing the ERASE foot switch as required to clear the screen. When the hole signal is visible on the NORTEC 600 screen, press the FREEZE key (❄).

TIP

When scanning over the hole in a pulling motion, the probe's lower signal lobe should appear first on the screen (see Figure 5-226 on page 289 and Figure 5-227 on page 289).

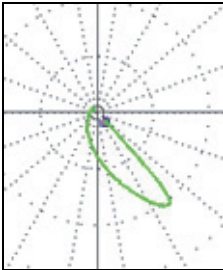

Figure 5-226 Example of lower signal lobe when pulling the probe over a flaw

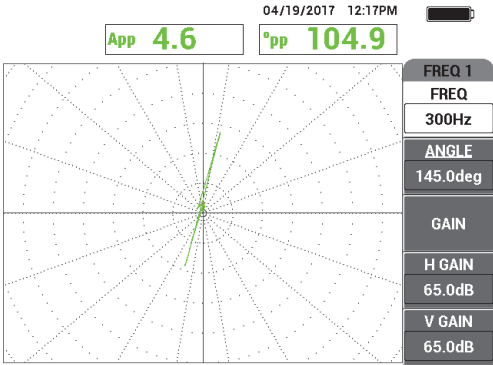



Figure 5-227 The scan signal of the thru-wall hole

- 3. Press the ANGLE key () , and then rotate the signal until the hole signal is vertical (see Figure 5-228 on page 290).

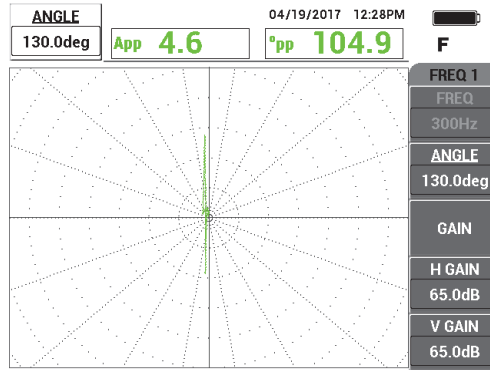

Figure 5-228 Adjusting the signal phase

4. Press the GAIN key (**dB**), and then increase the gain until the hole signal reaches about 6 vertical divisions in height (see Figure 5-229 on page 290). If necessary, adjust the ANGLE after you have increased the gain.

IMPORTANT

Always use combined horizontal and vertical gain (H/V GAIN).

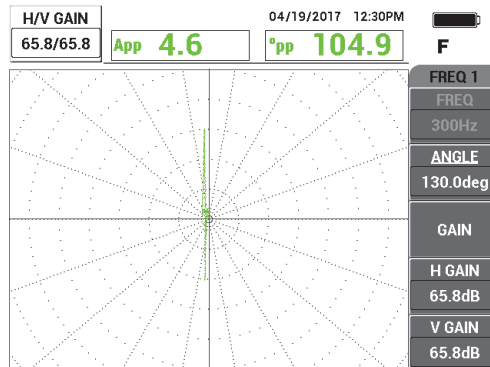

Figure 5-229 Adjusting the gain

5. Press the FREEZE key (❄️) to enable signal acquisition.
6. Press the DISP menu key (□), followed by **DSP MODE** (display mode, A key), and then rotate the knob until **SWP + IMP** (sweep plus impedance) is displayed (see Figure 5-230 on page 291).

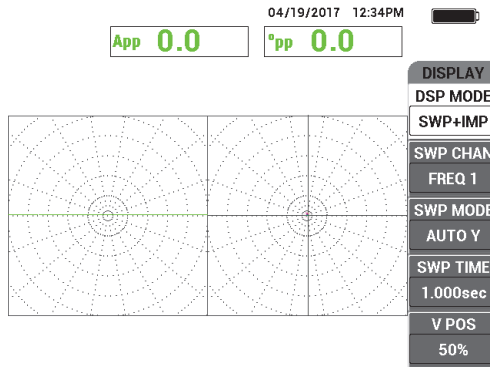

Figure 5-230 The SWP + IMP display

7. Press **SWP TIME** (D key) and adjust the sweep time to accommodate the length of the tube being inspected.
8. Place the probe in a defect-free area of the calibration standard near the thru-wall hole, and then press the NULL foot switch.
9. Slowly scan the tube.

The scan result should be similar to that shown in Figure 5-231 on page 292. The **SWP** (sweep) display on the left of the screen clearly shows the larger indications (full screen) that represent the 40 % and 60 % wall-loss flaws. The center (smaller) indication represents the thru-wall hole.

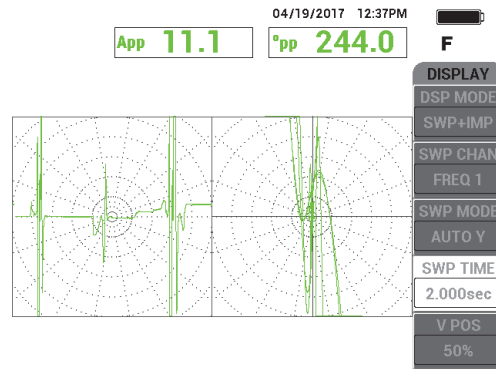

Figure 5-231 The SWP + IMP display after inspecting the entire tube

5.4.6 NFT Erosion and Corrosion (Absolute) — NORTEC 600D Model

In this near-field testing (NFT) application, an absolute configuration is used to identify volumetric or gradual internal defects such as erosion and corrosion in finned air-cooler tubing. An example NFT probe is shown in Figure 5-232 on page 292.



Figure 5-232 An NFT probe with an absolute exciter-pickup configuration

The absolute configuration helps quantify the amount (depth) of internal wall loss in tubing (see Figure 5-233 on page 293). The NORTEC 600 simply measures the corresponding amplitude of the absolute liftoff signal using the divisions of the impedance plane grid.

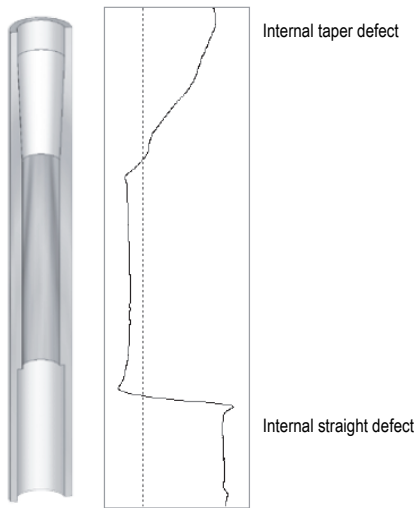

Figure 5-233 Example signal response (NFT absolute configuration)

This application uses inspection materials similar to the example illustrated in Figure 5-135 on page 222 (in the application “Inspecting Heat Exchanger Tubing Using Dual Frequency – NORTEC 600D Model” on page 221).

The following products are used in this procedure:

- Eddy current probe; P/N: TRD-170-300-N05 [Q2800326]
- Absolute near-field probe adapter (P/N: CBAS-10820-0001 [Q7670053])
- Calibration standard; P/N: CT45-009-F12 [Q7800048]
- Convenient, highly recommended items (however, not mandatory): foot switch (P/N: 9522333 [Q7670007]), foot switch armored cable (P/N: 9122404 [Q7670008]), and foot switch adapter (P/N: 9522336 [Q2500083])

To set the initial NORTEC 600 configuration

1. Connect the adapter, probe, and foot-switch adapter cable to the PROBE connector on the NORTEC 600.

2. Select **CONTINUE** (press the A key) to open the application selection menu, and then use the knob to select **NFT Erosion and Corrosion**, and press ✓ to accept (see Figure 5-234 on page 294).

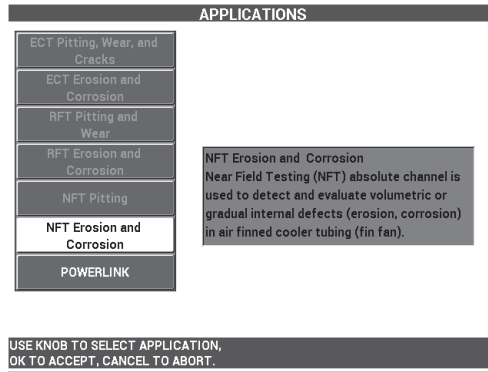

Figure 5-234 The NFT Erosion and Corrosion application

To calibrate the signals

1. Place the probe in a defect-free area of the calibration standard near the 60 % wall-loss groove, and then press the NULL foot switch.
2. Slowly scan the 60 % wall-loss flaw only, pressing the ERASE foot switch as required to clear the screen. When the flaw signal is visible on the NORTEC 600 screen, press the FREEZE key (❄) [see Figure 5-235 on page 295].

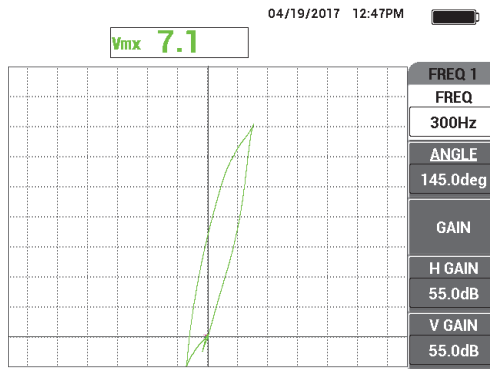



Figure 5-235 The scan signal of the 60 % wall-loss groove

3. Press the ANGLE key () , and then rotate the signal until the 60 % wall-loss groove signal is vertical (see Figure 5-236 on page 295).

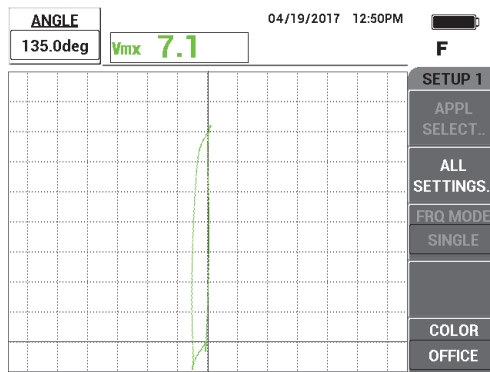

Figure 5-236 Adjusting the signal phase

4. Press the GAIN key (**dB**), and then increase the gain until the flaw signal reaches about 6 vertical divisions in height (see Figure 5-237 on page 296). If necessary, adjust the ANGLE after you have increased the gain.

IMPORTANT

Always use combined horizontal and vertical gain (**H/V GAIN**).

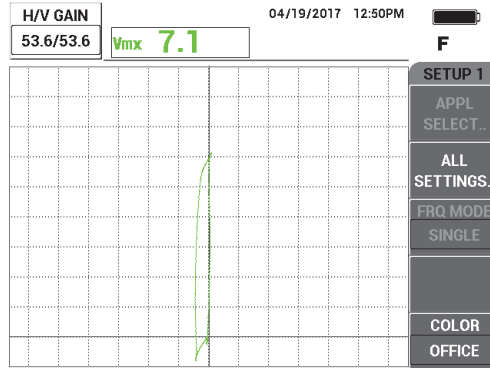

Figure 5-237 Adjusting the gain

5. Press the FREEZE key (❄️) to enable signal acquisition.

NOTE

If you adjust your instrument settings in this manner, you can size the defect using the **VMAX** display on the instrument, as shown in the images of Figure 5-238 on page 297.

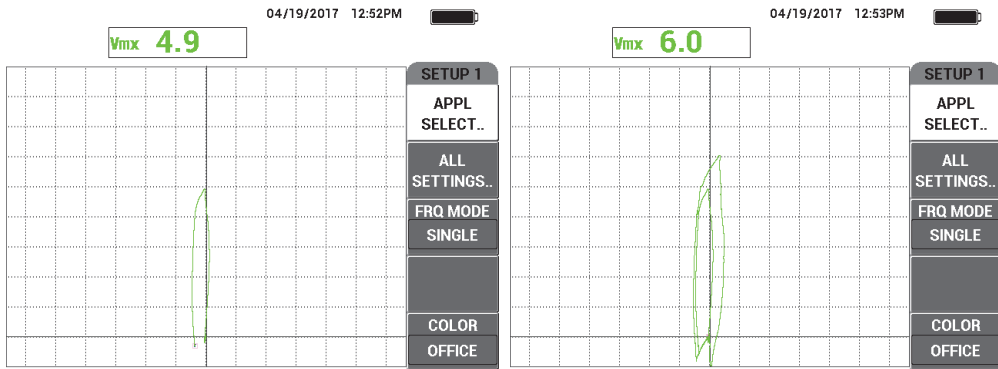



Figure 5-238 The 40 % wall-loss groove (*left*) and 60 % wall-loss groove (*right*)

6. Press the DISP menu key () , followed by **DSP MODE** (display mode, A key), and then rotate the knob until **SWP + IMP** (sweep plus impedance) is displayed.
7. Press **SWP TIME** (D key) and adjust the sweep time to accommodate the length of the tube being inspected.
8. Place the probe in a defect-free area of the calibration standard near the 60 % wall-loss flaw, and then press the NULL foot switch.
9. Slowly scan the tube.

The scan result should be similar to that shown in Figure 5-239 on page 298. The **SWP** (sweep) display on the left of the screen clearly shows the flaws in the tube. The larger indications (full screen) represent the 40 % and 60 % wall-loss flaws. The center (very small) indication represents the thru-wall hole.

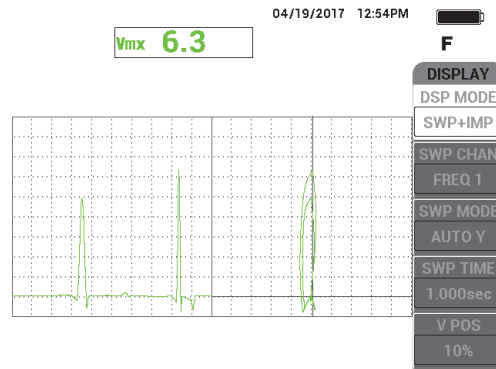

Figure 5-239 The SWP + IMP display after inspecting the entire tube

5.5 Alarm Menu

The NORTEC 600 instrument's alarm options include **BOX**, **SWEEP**, **SECTOR**, or **POLAR**. Up to three alarms may be used at any time. You can define the size, shape, position, and polarity of each alarm. Owing to the number of alarm options, the alarm definitions are grouped into submenus in the definition menu (**DEFINE**). There is a submenu for each alarm that is enabled (**ALARM 1**, **ALARM 2**, and **ALARM 3**).

5.5.1 Alarm DEFINE Menu

The **DEFINE** menu is used to enable alarms and to set alarm polarity, the length of time an alarm is active, and whether or not an alarm is audible. The **DEFINE** menu's available controls are **ALARM 1**, **ALARM 2**, **ALARM 3**, **DWELL**, and **HORN** (see Figure 5-240 on page 299). Control functions for single frequency instruments (NORTEC 600, 600C, and 600S models) are described below. Additional details for alarms in dual frequency mode (NORTEC 600D) are detailed in "Dual Frequency Menus" on page 115.

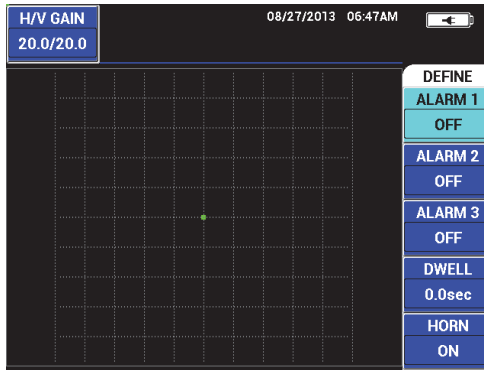

Figure 5-240 Alarm DEFINE menu

ALARM 1

Enables **ALARM 1**, and selects a positive or negative polarity (**FRQ1 POS** or **FRQ1 NEG**) and turns off the alarm (**OFF**). By default, this alarm is set to **OFF**.

ALARM 2

Enables **ALARM 2**, and selects a positive or negative polarity (**FRQ1 POS** or **FRQ1 NEG**) and turns off the alarm (**OFF**). By default, this alarm is set to **OFF**.

ALARM 3

Enables **ALARM 3**, and selects a positive or negative polarity (**FRQ1 POS** or **FRQ1 NEG**) and turns off the alarm (**OFF**). By default, this alarm is set to **OFF**.

DWELL

Enables the length of time the instrument stays in an alarm condition after the alarm threshold has been reached. **DWELL** can be set for a time period between 0 seconds and 10 seconds, in 0.2 second intervals. **DWELL** affects both the internal and the external **HORN**, and the screen's display indicators. By default, **DWELL** is set to 0 seconds.

HORN

Enables and disables the internal and external **HORN**, or audible alarm (beep). The available settings are **ON** or **OFF**, and by default **HORN** is set to **OFF**.

To define an alarm

1. Press the ALARM menu key () to access the **ALARM 1** menu.

2. Press the A, B, or C key to highlight the alarm you wish to enable.
3. Use the knob to select the alarm's polarity; **FRQ1 POS** enables a positive polarity alarm and **FRQ1 NEG** enables a negative polarity alarm (see Figure 5-241 on page 300).

After you have selected the polarity (**FRQ1 POS** or **FRQ1 NEG**), a box is displayed on the screen.

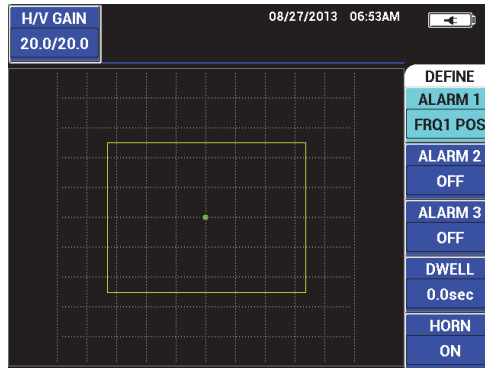



Figure 5-241 Alarm polarity

4. Press the D key to highlight the alarm **DWELL** time, and then use the knob to adjust the **DWELL** time to the desired value (0.0 s to 10.0 s, in 0.2 s intervals).
5. Press the E key to enable the alarm **HORN**, and then rotate the knob to the desired value (**ON** or **OFF**).

5.5.2 Selecting the Alarm Shape and Position — Alarm 1, 2, and 3 Menus

The shape and position is defined individually for each alarm.

To select the alarm shape and position

1. Press the ALARM menu key () to access the **ALARM 1** menu.
2. Press the A key to highlight the alarm **SHAPE**, and then use the knob to select the desired alarm type: **BOX**, **SWEEP**, **SECTOR**, or **POLAR** (see Figure 5-242 on page 301).

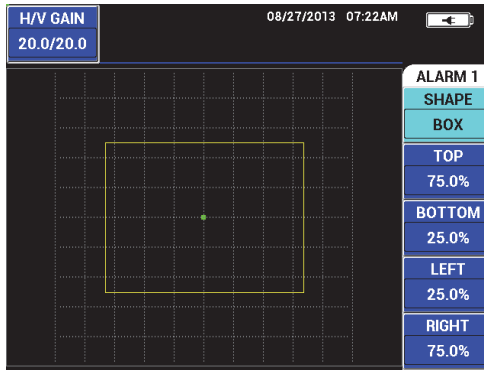



Figure 5-242 Alarm menu

3. Use the B, C, D, and E keys (as required) to select the position and change the shape (and size) of the alarm.
4. If necessary, press the ALARM menu key () to access **ALARM 2** or **ALARM 3**, and then change the shape and position by repeating steps 1 through 3.

5.5.3 SWEEP alarm

The sweep alarm's position can be adjusted vertically and horizontally, but only if the sweep function is enabled.

NOTE

The following procedure assumes that **ALARM 1** is being used as the sweep alarm.

To adjust the position for the sweep alarm

1. Press the A key, and then use the knob to select the alarm polarity. After the polarity is selected, a box is displayed on the screen (see Figure 5-243 on page 302).

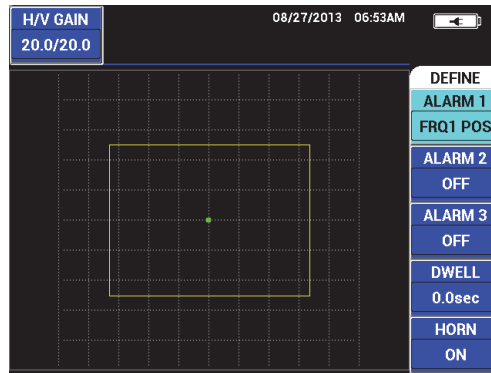



Figure 5-243 Alarm polarity

2. Press the D key to highlight the alarm **DWELL** time, and then use the knob to adjust the **DWELL** time to the desired value (0.0 s to 10.0 s, in 0.2 s intervals).
3. Press the E key and then rotate the knob to the desired alarm **HORN** value (**ON** or **OFF**).
4. Press the ALARM menu key () to access the **ALARM 1** menu.
5. Press the A key to highlight the alarm **SHAPE**, and then use the knob to select **SWEEP**.
6. Press the B and C keys to alter the **TOP** and **BOTTOM** alarm levels.
7. If necessary, press the ALARM menu key () to access and adjust **ALARM 2** or **ALARM 3**.

6. NORTEC PC Software

The NORTEC PC software enables you to manipulate stored data, capture screen images, upgrade the instrument software, create PDFs, issue a command to the instrument, remotely control the instrument, unlock instrument options, and back up and restore the instrument settings.

The NORTEC PC software is included on a CD-ROM as a standard accessory with the NORTEC 600 instrument. This software allows a PC (computer) to communicate with the NORTEC 600 instrument. The default communication protocol for the NORTEC 600 is USB 2.0.

6.1 Importing Files

Data files can be imported from the NORTEC 600 instrument into a PC using the NORTEC PC software's **Import File Wizard**. The Wizard automatically opens when NORTEC PC starts up.

To import files from the NORTEC 600 instrument

1. Click **Next** to initiate the Wizard's file importation process (see Figure 6-1 on page 304).

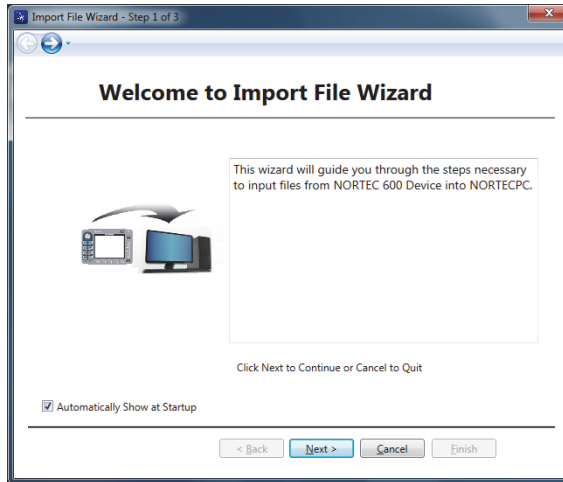

Figure 6-1 The Import File Wizard dialog box

2. Use the **Browse** button to choose the folder location where you want to save the imported files, and then click **Next** (see Figure 6-2 on page 304).

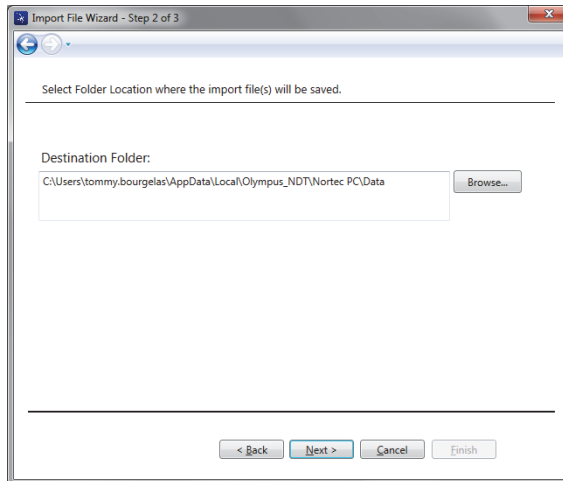

Figure 6-2 The Import File Wizard folder selection

- 3. Select the files to import (or, select **Select all files** to import all files), and then click **Import** (see Figure 6-3 on page 305).
The progress of the importation process is displayed in the status bar (see Figure 6-4 on page 305).

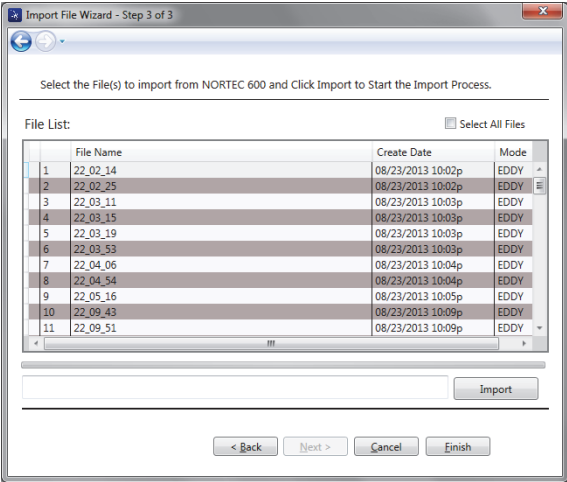

Figure 6-3 The Import File Wizard file selection

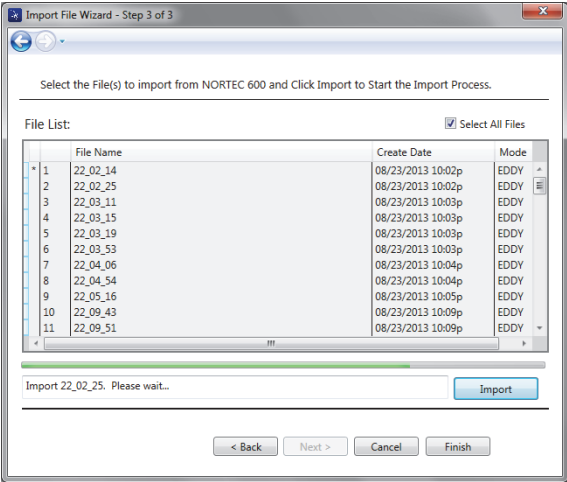

Figure 6-4 The Import File Wizard transfer process start

- After all files have been transferred, click **Finish** to exit the Wizard (see Figure 6-5 on page 306)

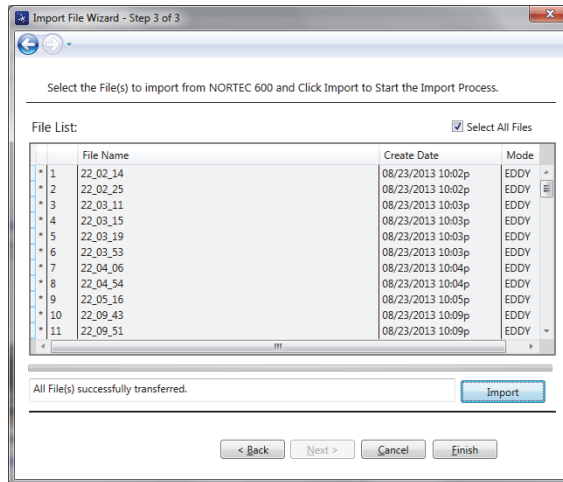

Figure 6-5 The Import File Wizard transfer process completion

6.2 Capturing a Screen Image Using NORTEC PC

The NORTEC PC software allows you to capture screen images while operating the NORTEC 600 instrument. For details about screen captures performed without NORTEC PC, see “Hidden Function — Screen Capture” on page 84.

To capture a screen image using the NORTEC PC software

- Start the NORTEC PC software.
- Connect the PC to the instrument using a USB cable.
- On the **Device** menu, select **Capture Screen** (see Figure 6-6 on page 307).
The **Capture Screen** dialog box opens (see Figure 6-7 on page 307).

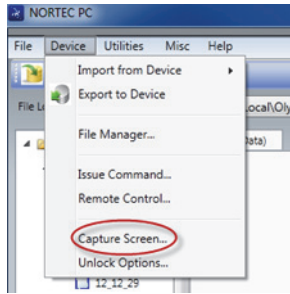

Figure 6-6 The NORTEC PC Device menu

4. In the **Capture Screen** dialog box, click **Start Capture** (see Figure 6-7 on page 307).

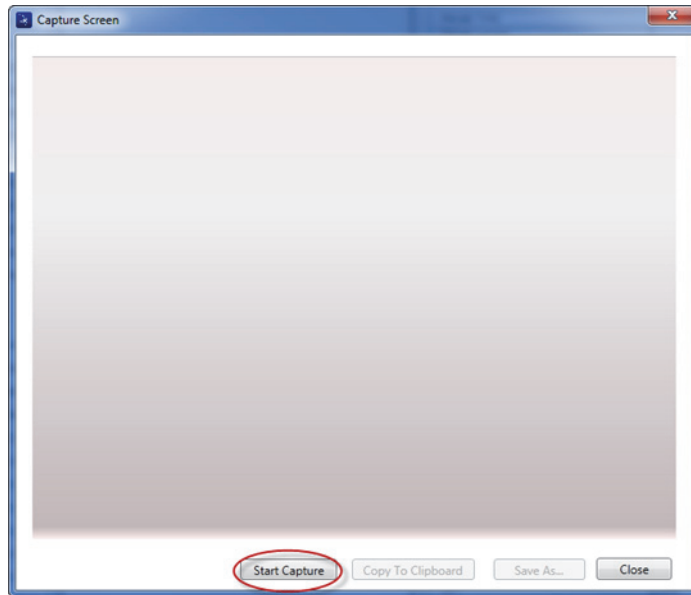

Figure 6-7 The Capture Screen dialog box

5. When the NORTEC PC has obtained the current instrument screen image, proceed as follows:

- ◆ Copy the image to the PC clipboard.
OR
Save the image to the PC hard drive or other memory device.

6.3 Upgrading the Instrument Software Using NORTEC PC

You are able to upgrade the NORTEC 600 instrument's software using NORTEC PC. The software upgrade must first be downloaded via the internet or other means and then saved to a file location on the PC.

To upgrade the NORTEC 600 instrument software

1. Connect the PC to the instrument using a USB cable.
2. Press the ADV SETUP menu key () twice.
3. Press the D key to open the **ABOUT** menu (see Figure 6-8 on page 308).

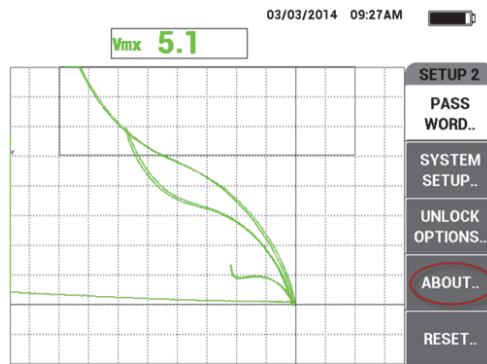

Figure 6-8 The ABOUT menu

4. Press the C key to select **UPGRADE** (see Figure 6-9 on page 309).

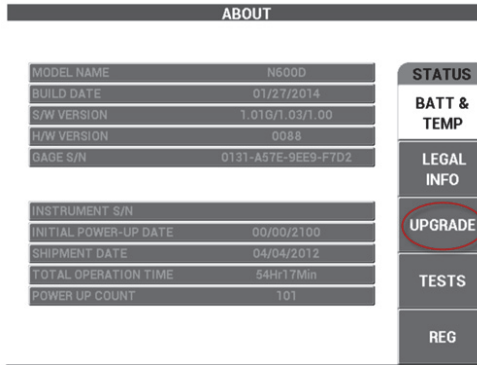

Figure 6-9 The UPGRADE menu

5. Connect the charger/adaptor to the NORTEC 600.
A message is displayed that indicates whether or not the charger/adaptor is connected (see Figure 6-10 on page 309 and Figure 6-11 on page 310).

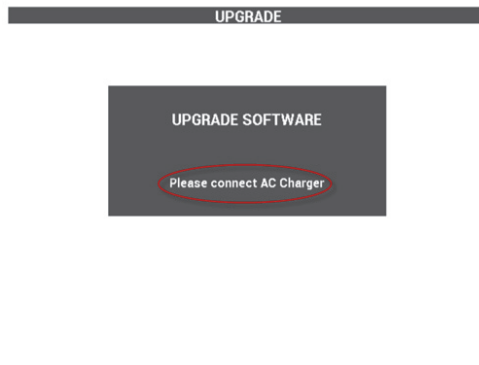

Figure 6-10 The message indicating the charger/adaptor is not connected

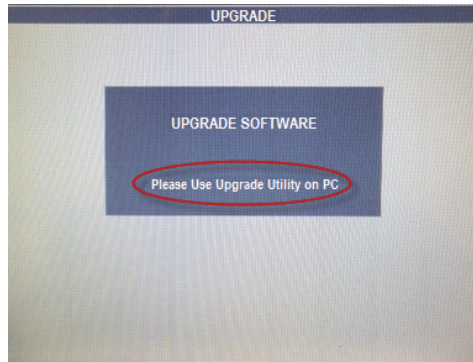

Figure 6-11 The message indicating the charger/adapter is connected

NOTE

The software upgrade will not proceed until the NORTEC 600 charger/adapter is connected to the NORTEC 600 instrument.

6. On the NORTEC PC **Utilities** menu, select **Upgrade** (see Figure 6-12 on page 310). The **Upgrade Device** dialog box opens (see Figure 6-13 on page 311).

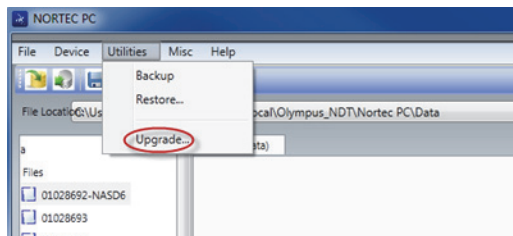

Figure 6-12 The Utilities menu

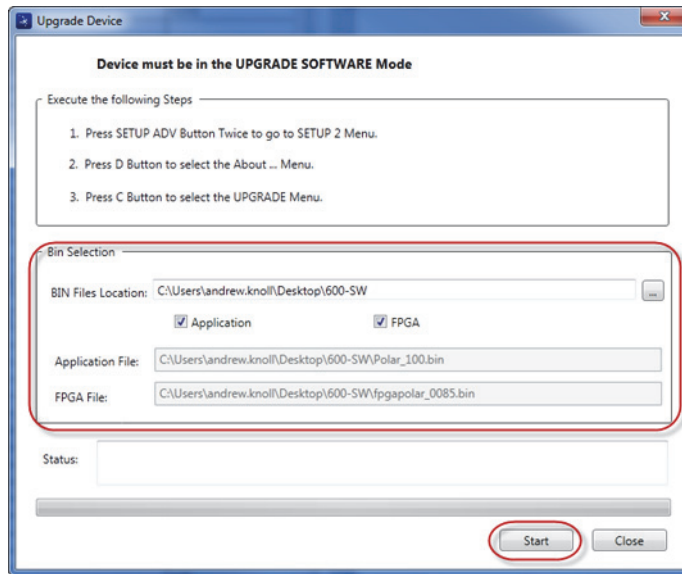

Figure 6-13 The Upgrade Device dialog box

7. Under **Bin Selection** in the **Upgrade Device** dialog box, choose the location of the NORTEC 600 update software, and then select the **Application** and **FPGA** check boxes (see Figure 6-13 on page 311).
8. Click **Start** to begin the update.
9. When the software update process has been completed, turn off the NORTEC 600 instrument, and then turn it back on again to activate the upgrade.

6.4 Upgrading the Instrument Software without NORTEC PC

If you are using NORTEC 600 software version 1.10 or higher, it is possible to upgrade the NORTEC 600 software by copying the upgrade files onto the microSD card. This way, NORTEC PC is not required. An upgrade using the microSD card is considerably faster than an upgrade using NORTEC PC.

To upgrade the NORTEC 600 software

1. Ensure that your NORTEC 600 instrument is turned off.

2. Remove the microSD card from the NORTEC 600, and insert it into the SD card reader on your computer.
3. Make sure to back up any files stored on the NORTEC 600.

IMPORTANT

Before starting the upgrade, check if your NORTEC 600 instrument storage contains any files you want to keep, and back them up if necessary. The file storage will be reset during the upgrading process, and any existing files on your instrument will be erased.

4. Download the latest software upgrade files from the Evident website.
The downloaded software upgrade is a ZIP file (.zip) that must be extracted to a folder on your computer. To do this you can, for example, create a temporary folder on your desktop.
5. Use your computer file manager or Windows Explorer to copy (CTRL+C) and paste (CTRL+V) the three software upgrade files onto the microSD card.
The following three files must copied onto your microSD card to enable successful upgrading:
 - Fpgapolar_xxx.bin (where xxx represents the FPGA version)
 - Polar_yyy.bin (where yyy represents the FPGA version)
 - Upgrade.ini
6. After you have copied all three files onto the microSD card, remove the card from your computer and insert it into the NORTEC 600.
7. Turn on the NORTEC 600, and connect it to the DC charger.

IMPORTANT

The DC charger must be connected before starting the upgrade. Otherwise, you cannot perform the upgrade.

8. Press the ADV SETUP menu key () twice.
9. Press the D key to open the **ABOUT** menu.
10. Press the C key to select **UPGRADE**.
Wait for the NORTEC 600 to upgrade.

After completing the upgrade through the microSD card, the NORTEC 600 shuts down automatically.

11. After the NORTEC 600 instrument has shut down, turn it on again.
12. Press the ADV SETUP menu key () twice.
13. Press the E key to open the **RESET** menu.
14. Use the knob to select **MASTER RESET**.
15. Press the A key to select **RUN RESET**.
16. Turn off the instrument.

6.5 Creating a PDF

NORTEC PC enables you to export inspection reports to a PC hard drive or memory device. You can either create an individual PDF file from selected data, or export all data as a series of PDF files.

If you select the **Export All Files As Adobe Acrobat (PDF)** option, all stored data on the NORTEC 600 instrument is automatically selected and used to create individual PDF files that are saved in a specified location. At the end of this process, the individual PDF files may be reviewed and printed using Adobe Acrobat or equivalent software. It is important to choose the destination folder (to which the files are to be exported) before exporting data in a PDF file.

To create a single PDF file from selected data

- ◆ Select the file in the left pane of the NORTEC PC window (see Figure 6-14 on page 313), and then select **Export As > PDF** (see Figure 6-15 on page 314)

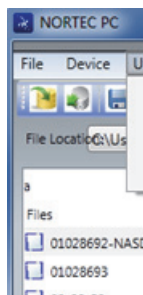

Figure 6-14 Files in the left pane of the NORTEC PC window

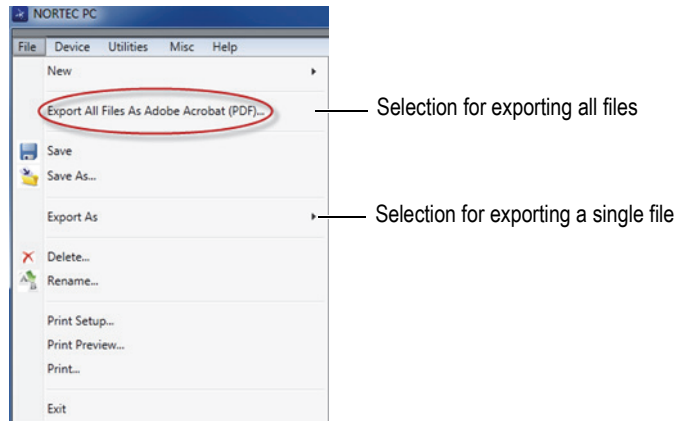

Figure 6-15 The File menu

To export all data using the Export All Files As Adobe Acrobat (PDF) option

- ◆ On the NORTEC PC File menu, select **Export All Files As Adobe Acrobat (PDF)** [see Figure 6-15 on page 314].

6.6 Issuing Remote Commands to the NORTEC 600 from a PC

You can issue single read, write, or execute commands to the NORTEC 600 instrument using the NORTEC PC software. A complete table of the available remote commands is included at the end of this section.

To view the full list of commands

- ◆ On the **Help** menu, select **Remote Command** (see Figure 6-16 on page 314). The command list opens in a separate window using the PC's default software for viewing PDF files.

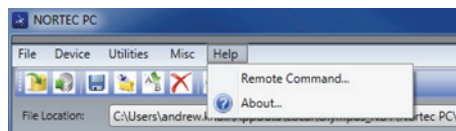

Figure 6-16 Selecting the Remote Command

To issue remote commands

- 1. On the **Device** menu, select **Issue Command** (see Figure 6-17 on page 315).
The **Issue Command** dialog box opens (see Figure 6-18 on page 315).

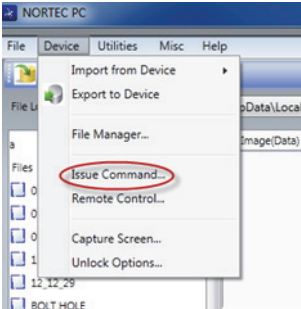

Figure 6-17 The Device menu – Issue Command

- 2. In the **Issue Command** dialog box, enter a command (see Figure 6-18 on page 315).

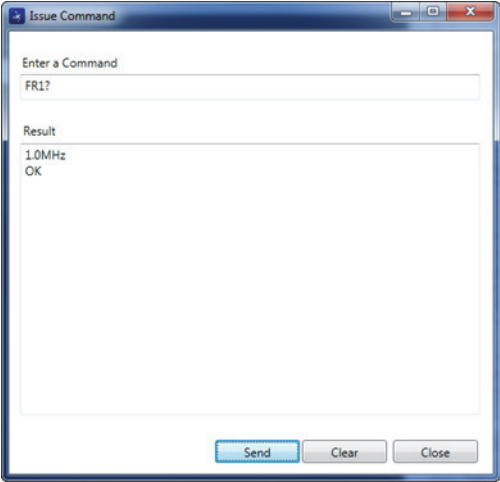

Figure 6-18 The Issue Command dialog box

NOTE

Commands may be read (R), written (W) or executed (X). Table 5 on page 316 lists the commands and the format in which they must be written.

3. In the **Issue Command** dialog box, click **Send** (see Figure 6-18 on page 315).

OR

Press Enter on your PC keyboard.

The NORTEC 600 remote command convention is as follows:

- Read (R) commands end with “?”
Example: AN1?
- Write (W) commands include “=” followed immediately by a value without any spaces
Example: AN1=45
- Execute (X) commands include only the command
Example: DLB

NOTE

All commands end with a carriage return and line feed (entered as “\r\n”). Any space in a Write command should be replaced with an underscore character.

Table 5 NORTEC 600 remote commands

Command	Description	R/W/X	Range/valid strings	
			Min	Max
ADW	Alarm Dwell	R/W	0.005	10.000
AN1	Angle 1	R/W	0.000	359.900
AN2	Angle 2	R/W	0.000	359.900
ANI	Angle Step Increment	R/W	0.100	
ASE	Sweep Erase	R/W	ON/OFF	
AST	Auto Sweep Time	R/W	0.005	10.000

Table 5 NORTEC 600 remote commands (continued)

Command	Description	R/W/X	Range/valid strings	
			Min	Max
AS1	Alarm Type 1	R	BOX/SWEEP/SECTOR/POLAR	
AS2	Alarm Type 2	R	BOX/SWEEP/SECTOR/POLAR	
AS3	Alarm Type 3	R	BOX/SWEEP/SECTOR/POLAR	
AUE	Auto Erase After Null	R/W	ON/OFF	
BAT	Predicted Batt Capacity	R	0	100
BATT	Predicted Batt Capacity	R	0	100
BMP	Screenshot	X		
CAE	Conductivity Alarm Polarity	R/W	OFF/POSITIVE/NEGATIVE	
CAL	Conductivity Alarm Lower	R/W	1.0 (U.S. units); 0.6 (Metric units)	109.9 (U.S. units); 63.8 (Metric units)
CAU	Conductivity Alarm Upper	R/W	1.1 (U.S. units); 0.6 (Metric units)	110.0 (U.S. units); 63.8 (Metric units)
CCM	Capture Mode	R/W	REPRESS/CONT	
CCP	Calibration Point	R/W	0	4
CCT	Capture Time	R/W	2.5	120.0
CCV	Calibration Value	R	0.9 (U.S. units); 0.52 (Metric units)	110.0 (U.S. units); 63.8 (Metric units)
CLD	Datalogger Clear	X	N/A	N/A
CLP	Datalogger Clear	X	N/A	N/A
CND	Conductivity	R	N/A	N/A
CNL	Set Continuous Null	R/W	OFF/0.2Hz/0.5Hz/1.0Hz	
CNU	Conductivity Units	R/W	%IACS/MS/m	

Table 5 NORTEC 600 remote commands (continued)

Command	Description	R/W/X	Range/valid strings	
			Min	Max
CSH	LCD Color Section	R	DEFAULT/OUTDOORS/ RED/YELLOW/BLUE/ PINK/OUTDOORS 2/OFFICE	
CTE	Display Erase Time	R/W	0.0	60.0
DAL	Data Location	R/W	1	# Entries in Datalogger
DAT	Clock Date	R	MM/DD/YYYY or DD/MM/YYYY (depending on system setup)	
DAY	Day	R/W	1	31
DCM	Capture Mode	R/W	INSTANT/DELAYED	
DLB	Datalogger Backup	X	N/A	N/A
DLR	Datalogger Restore	X	N/A	N/A
ERS	Screen Erase	X	N/A	N/A
FHI	Frequency High Pass	R/W	0.0	500.0
FLO	Frequency Low Pass	R/W	10.0	2500.0
FR1	Frequency 1	R/W	10	12000000
FR2	Frequency 2	R/W	10	12000000
FRZ	Screen Freeze	X	N/A	N/A
FSD	Frequency Mode	R/W	SINGLE/DUAL	
GN1	Frequency Gain 1	R/W	0.0	100.0
GN2	Frequency Gain 2	R/W	0.0	100.0
GAGECONFIGDATE	Gage Shipment Date	R	MM/DD/YYYY	
GAGEINITDATE	Gage Initial Power Up Date	R	MM/DD/YYYY	
HG1	Freq 1 Hor Gain	R/W	0.0	100.0

Table 5 NORTEC 600 remote commands (*continued*)

Command	Description	R/W/X	Range/valid strings	
			Min	Max
HG2	Freq 2 Hor Gain	R/W	0.0	100.0
HPO	Horizontal Position	R/W	-16	116
HRN	Alarm Horn Volume	R/W	ON/OFF	
HWV	Hardware Version	R	DxD DD where D is 0–9	
HW?	Hardware Version	R	DxD DDD where D is 0–9	
IACS1	Conductivity Calibration value position 1 and 3	R/W	0	120
IACS2	Conductivity Calibration value position 2 and 4	R/W	0	120
ISN	Instrument Serial Number	R	N/A	N/A
KEY	Key Command	W	MAIN/DISPLAY/ALARM/MEMORY/SETUP/NUL/ERASE/SAVE/FREEZE/AUTO-LIFT/REF/GAIN/ANGLE/ENTER/ESCAPE/NEXT/FULL_NEXT/ A/B/C/D/E	
KNOB	Knob Command	W	CCW/CW/UP/DOWN	
LAN	Language	R/W	GERMAN/JAPANESE/CHINESE/ RUSSIAN/SWEDISH/ ITALIAN/PORTUGUESE/NORWEGIAN/HUNGARIAN/POLISH/DUTCH/ CZECH	
LDN	Last Filled Data Loc	R	Max number of files	
LID	Load Instrument Default Settings	X	N/A	N/A

Table 5 NORTEC 600 remote commands (continued)

Command	Description	R/W/X	Range/valid strings	
			Min	Max
LPN	Last Filled Data Loc	R	Max number of files	
MGN	Horizontal Mixer Gain	R/W	-6.0	18.0
MPD	Powerlink Probe Mode	R	String describing mode	
MPS	Powerlink Probe S/N #	R	String of Serial Number	
NAM	Instrument Name	R	N600/N600S/N600C/N600D	
PCM	Radix Point	R/W	PERIOD (.) / COMMA (,)	
PDR	Probe Drive	R/W	LOW/MEDIUM/HIGH	
PGL	Program Location	R	Selected file name	
POX1?	FREQ 1 current dot position from NULL — horizontal	R	-13.333	13.333
POX2?	FREQ 2 current dot position from NULL — horizontal	R	-13.333	13.333
POXY1?	FREQ 1 current dot position from NULL — horizontal and vertical	R	-13.333	13.333
POY1?	FREQ 1 current dot position from NULL — vertical	R	-13.333	13.333
POY2?	FREQ 2 current dot position from NULL — vertical	R	-13.333	13.333
POXY2?	FREQ 2 current dot position from NULL — horizontal and vertical	R	-13.333	13.333
PRE	Pre Amplifier	R/W	ON/OFF	

Table 5 NORTEC 600 remote commands (continued)

Command	Description	R/W/X	Range/valid strings	
			Min	Max
PTP	Powerlink Probe Type	R	REFLECTION REFLECTION/ABSOLUTE REFLECTION/ DIFFERENTIAL BRIDGE/ BRIDGE/ABSOLUTE REFLECTION/DIFFERENTIAL	
POWERUP	Total Operation Time	R	Number	
RDI	Instrument Battery Current	R	N/A	N/A
RDV	Instrument Battery Voltage	R	N/A	N/A
RLK	Lock	R	ON/OFF	
RPM	Scanner RPM	R/W	600	3000
RUNTIME	Total Run Time	R	N/A	N/A
SCZ	Scanner Sync Angle	R/W	0	359
SEC	Seconds	R/W	0	59
SNO	Gage Serial Number	R	XXXX-XXXX-XXXX-XXXX, where X is 0–9, A–F	
SW?	Software Version	R	N/A	
SWP	Sweep Mode	R	AUTO Y/AUTO XY/ EXT Y/ EXT XY	
TIM	Clock Time	R	XX:XX	
UI1	User Info 1	R/W	Max 40 Characters – No spaces. Use “{” character for space.	
UI2	User Info 2	R/W	Max 40 Characters – No spaces. Use “{” character for space.	
UI3	User Info 3	R/W	Max 40 Characters – No spaces. Use “{” character for space.	

Table 5 NORTEC 600 remote commands (continued)

Command	Description	R/W/X	Range/valid strings	
			Min	Max
UI4	User Info 4	R/W	Max 40 Characters – No spaces. Use “ ” character for space.	
UI5	User Info 5	R/W	Max 40 Characters – No spaces. Use “ ” character for space.	
UI6	User Info 6	R/W	Max 40 Characters – No spaces. Use “ ” character for space.	
UI7	User Info 7	R/W	Max 40 Characters – No spaces. Use “ ” character for space.	
UI8	User Info 8	R/W	Max 40 Characters – No spaces. Use “ ” character for space.	
UI9	User Info 9	R/W	Max 40 Characters – No spaces. Use “ ” character for space.	
UI10	User Info 10	R/W	Max 40 Characters – No spaces. Use “ ” character for space.	
UI11	User Info 11	R/W	Max 40 Characters – No spaces. Use “ ” character for space.	
UI12	User Info 12	R/W	Max 40 Characters – No spaces. Use “ ” character for space.	
UI13	User Info 13	R/W	Max 40 Characters – No spaces. Use “ ” character for space.	
UI14	User Info 14	R/W	Max 40 Characters – No spaces. Use “ ” character for space.	
UI15	User Info 15	R/W	Max 40 Characters – No spaces. Use “ ” character for space.	
VAP	Variable Persistence	R/W	0.0	10.0
VER	Software Version	R	N/A	N/A
VG1	Freq 1 Vert Gain	R/W	0.0	100.0
VG2	Freq 2 Vert Gain	R/W	0.0	100.0

Table 5 NORTEC 600 remote commands (continued)

Command	Description	R/W/X	Range/valid strings	
			Min	Max
VMG	Vertical Mixer Gain	R	-6.0	18.0
VPO	Vertical Position	R/W	0	100
WST	Waterfall Start	R/W	1	57
WEN	Waterfall End	R/W	4	60
WCU	Waterfall Cursor	R/W	0	60
WER	Waterfall Erase	R/W	MANUAL/AUTO	
YR.	Year	R/W	2013	2100

6.7 Remotely Controlling the NORTEC 600 from a PC

You can use the NORTEC PC **Remote Control** function to remotely control the NORTEC 600. This is especially useful when the equipment is being used in hot cell areas (shielded nuclear radiation containment chambers) or for training purposes.

To enable the NORTEC PC remote control function

1. Click **Remote Control** in the **Device** menu (see Figure 6-17 on page 315).
The software's **Remote Command** dialog box will display an image of the front face of the NORTEC 600, including its control buttons and display (see Figure 6-19 on page 324).
2. Control the instrument in much the same way as you would if it were in front of you.

NOTE

To display the instrument screen, you must first click **Refresh Screen** in the **Remote Command** dialog box (see Figure 6-19 on page 324). For simultaneous setting verification, use the instrument display or an external monitor.



Figure 6-19 The Remote Command dialog box

To use the knob function in remote control operation

- ◆ In remote control mode, click the top half of the knob to increase setting values and click the bottom half of the knob to decrease setting values (see Figure 6-20 on page 325).

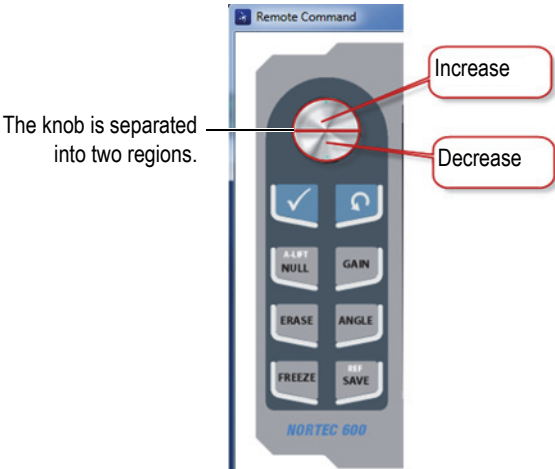

Figure 6-20 The knob functions in remote control operation

6.8 Managing Files on the NORTEC 600 from your PC

You can use the NORTEC PC software’s **File Manager** to rename, delete, and recall files that are stored on the NORTEC 600.

To access the File Manager

- ◆ On the NORTEC PC software **Device** menu, select **File Manager** (see Figure 6-21 on page 325).
The **Manage File** dialog box appears (see Figure 6-22 on page 326).

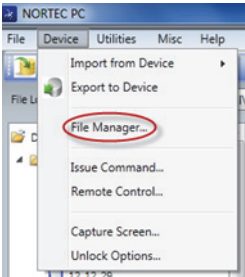

Figure 6-21 The File Manager command

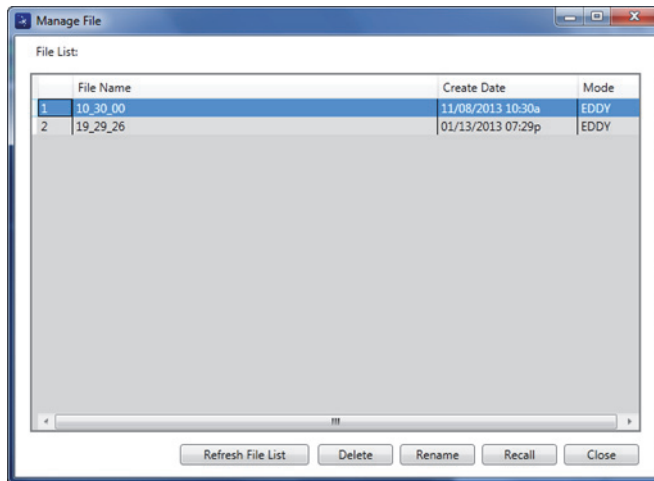

Figure 6-22 The Manage File dialog box

The following functions are available in the **Manage File** dialog box:

- **Delete** — delete files on the NORTEC 600 instrument.
- **Rename** — rename files on the NORTEC 600 instrument, which is especially useful when naming files related to a specific inspection or customer.
- **Recall** — recall a file on the NORTEC 600 instrument.
- **Refresh File List** — refresh the file list in the NORTEC PC software.

To delete a file on the NORTEC 600

1. In the **Manage File** dialog box, choose the file to be deleted, and then click **Delete**. The **Confirmation** dialog box appears, asking you to confirm that you want to delete the file on the device (see Figure 6-23 on page 327).

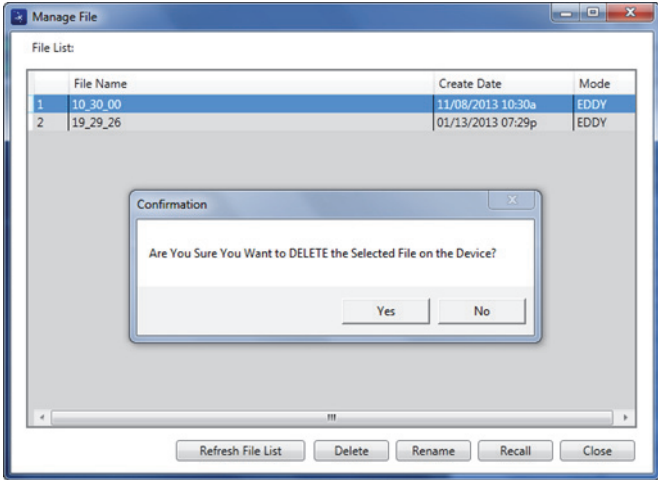

Figure 6-23 The Confirmation dialog box for file deletion

- 2. Click **Yes** to confirm file deletion, which is permanent; the file cannot be retrieved later.
OR
Click **No** to cancel the file deletion.

To rename a file on the NORTEC 600

- 1. In the **Manage File** dialog box, choose the file to be renamed, and then click **Rename** (see Figure 6-22 on page 326).
The **Rename** dialog box appears (see Figure 6-24 on page 327).

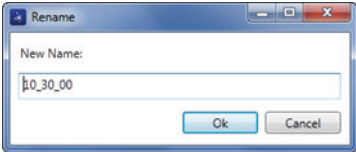

Figure 6-24 The Rename dialog box

- 2. In the **Rename** dialog box, enter the new file name.

By default, the NORTEC 600 includes a military time stamp in the file name in HH_MM_SS (Hour_Minute_Second) format.

3. Click **OK** to save the new file name.

To recall a file on the NORTEC 600

1. In the **Manage File** dialog box, choose the file to be recalled, and then click **Recall** (see Figure 6-22 on page 326).

The **Confirmation** dialog box appears, asking you to confirm that you want to recall the selected file (see Figure 6-25 on page 328).

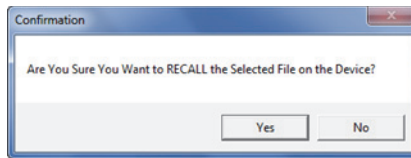

Figure 6-25 Message asking you to confirm the recall

2. Click **Yes** to confirm the file recall, which will overwrite all previous settings and which cannot be undone.
OR
Click **No** to cancel the file recall.

To refresh the program file list

- ◆ In the **Manage File** dialog box, click **Refresh File List** (see Figure 6-22 on page 326).

6.9 Unlocking NORTEC 600 Upgrade Options with your PC

Using NORTEC PC and a license key purchased from Evident, you can easily upgrade the software of your NORTEC 600 model. The **Unlock Option** function included in the NORTEC PC software makes it unnecessary to send the instrument to the factory for an upgrade. For greater flexibility, all NORTEC 600 models have identical hardware that is capable of full functionality.

To unlock options

1. Connect your PC to the instrument using a USB cable.
2. On the NORTEC PC software **Device** menu, select **Unlock Options** (see Figure 6-26 on page 329).

The **Unlock Options** dialog box opens (see Figure 6-27 on page 329).

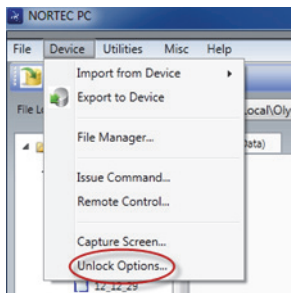

Figure 6-26 The Unlock Options command

3. In the **Unlock Options** dialog box, enter the license key, and then click **OK**.

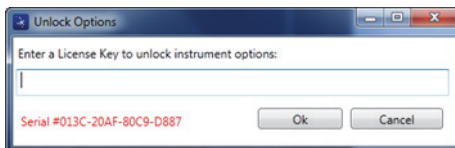

Figure 6-27 The Unlock Options dialog box

4. Turn off, and then turn on the NORTEC 600.
After cycling the power, the new NORTEC 600 instrument features are unlocked and ready for use.

6.10 Backing Up the NORTEC 600 Files

The NORTEC PC software enables you to easily back up and clone your NORTEC 600 files. The backup file is stored externally on the microSD memory card of the NORTEC 600 being backed up.

To back up a NORTEC 600

1. Connect the PC to the instrument using a USB cable.
2. Make sure that a microSD card is inserted into the microSD card of the NORTEC 600 (see Figure 6-28 on page 330).

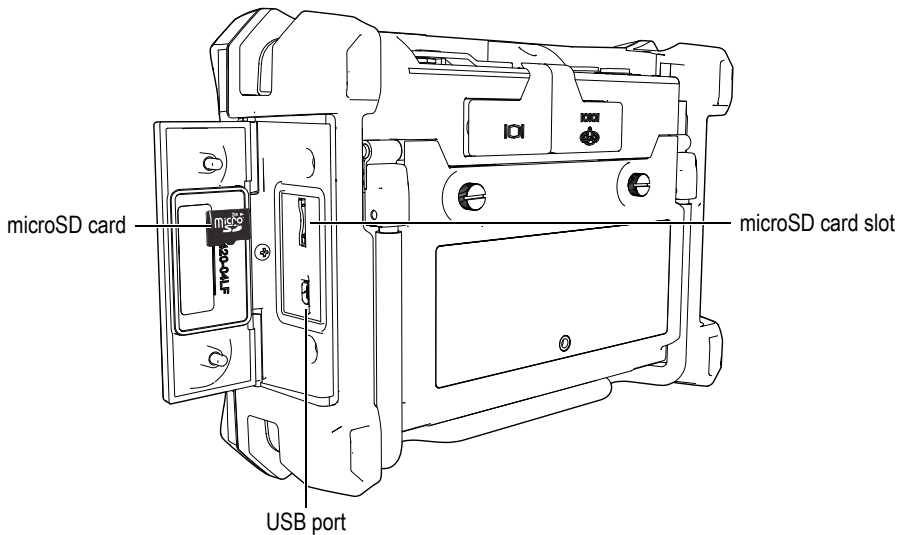

Figure 6-28 The microSD card location

3. On the NORTEC PC software **Utilities** menu, select **Backup** (see Figure 6-29 on page 331).

The **Backup** dialog box appears (see Figure 6-30 on page 331).

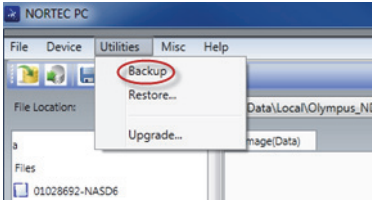

Figure 6-29 The Backup command

- 4. In the **Backup** dialog box, click **Start**.

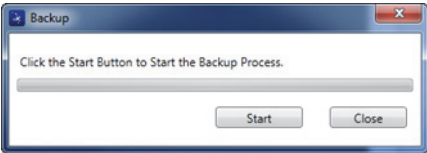

Figure 6-30 The Backup dialog box (start)

- 5. When the **Confirmation** dialog box appears (see Figure 6-31 on page 331), click **OK** to start the backup process.

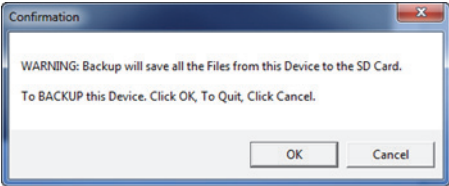

Figure 6-31 The Confirmation dialog box to confirm backup start

- 6. When the backup has been completed, click **Close** (see Figure 6-32 on page 332).

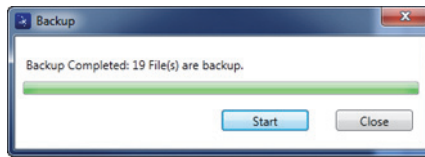

Figure 6-32 The Backup dialog box (complete)

6.11 Restoring or Cloning the NORTEC 600 Files

The NORTEC PC software enables you to easily restore or clone your NORTEC 600 files using a previously created backup file on the external microSD memory card of the instrument. This backup file is stored separately from the internal storage of the instrument so that it can overwrite (replace) the internally stored information if necessary. The instrument files can also be cloned from the backup file to create an exact copy, which can then be transferred from one instrument to another.

To restore a NORTEC 600

1. Connect the PC to the instrument using a USB cable.
2. Make sure that a microSD card is inserted in the microSD card slot of the NORTEC 600 (see Figure 6-28 on page 330).
3. On the NORTEC PC software **Utilities** menu, select **Restore** (see Figure 6-33 on page 332).

The **Restore** dialog box appears (see Figure 6-34 on page 333).

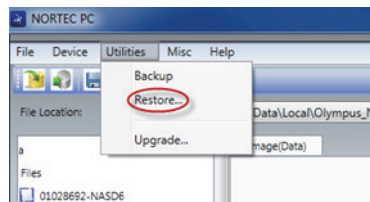

Figure 6-33 The Restore command

4. In the **Restore** dialog box, click **Start**.

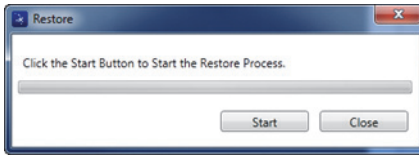

Figure 6-34 The Restore dialog box (start)

5. When the **Confirmation** dialog box appears (see Figure 6-35 on page 333), click **OK** to start the restore process.

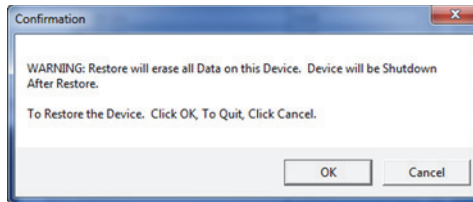

Figure 6-35 The Confirmation dialog box to confirm the restore start

NOTE

Restoring erases all content of the internal memory and replaces it with the data contained on the external microSD card.

6. When the restore process has been completed, click **Close** (see Figure 6-36 on page 333).

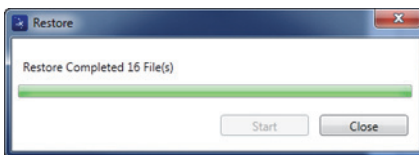

Figure 6-36 The Restore dialog box (complete)

7. Maintenance and Troubleshooting

The NORTEC 600 eddy current flaw detector is an industrial quality electronic instrument that requires very little maintenance. Most troubleshooting and maintenance procedures may be performed by the user. However, if problems persist, contact Evident for technical assistance.

7.1 Lithium-Ion Battery

Under normal operating conditions, the NORTEC 600 can operate on battery power for at least 8 hours between charges (for standard operation). As the battery power depletes, the percentage of remaining battery life is displayed on the battery indicator. When the battery charge becomes insufficient, the NORTEC 600 automatically turns off to prevent damage to the battery. Recharge the battery using the charger and power cord supplied with the unit.

Charging the Battery

The charger/adapter indicator light (battery charge LED) is red while the battery is charging, and turns green when the battery is fully charged. The approximate recharge time is two hours to three hours.

Replacing the Battery

Rechargeable batteries lose their ability to hold a full charge after several hundred recharges. For more information on installing and replacing the battery, see “Lithium-Ion Battery” on page 37 and “Alkaline Batteries” on page 38.

Disposing of Batteries

Batteries must be properly disposed of, in compliance with local regulations (see “Important Information — Please Read Before Use” on page 11).

7.2 Error Messages

The NORTEC 600 instrument may display error messages or indicate potential problems. If problems persist, contact Evident or your local sales and service representative for technical assistance.

No probe

When a probe is connected to the NORTEC 600 and this message appears, a failure in the identification circuit for the probe occurred. This problem is typically caused by a connection failure in the probe cable. Verify that the cable is connected to both the instrument and the probe, and that the cable is not damaged. Replace the cable (if a substitute cable is available), turn the instrument off, and then turn it back on.

Host is off-line

The NORTEC 600 is configured to send data through the USB port, but the NORTEC 600 fails to receive the correct “ready” (DSR) signal from the external datalogger. Verify the following:

- External device is powered on.
- External device is set to “serial” or “I/O” mode and is not malfunctioning.
- Appropriate data logging software is running (if the receiving device is a PC).
- Interface cable is securely fastened at both ends.
- Cable is compatible with the equipment and not damaged.

NOTE

The serial communication parameters **MUST** match those of the external device.

No data or garbled data received by external datalogger/host

If the NORTEC 600 is configured for serial mode, verify that the Comport parameters in the communication menu of the NORTEC 600 and external datalogger agree. Often, an incorrect Baud Rate is the problem.

7.3 Probe Care and Diagnostics

The probe is reliable and durable as long as it is carefully handled:

- Do not drop the probe on hard surfaces.
- Do not hit the probe with any objects.

The user may perform tests from the keypad to aid in localizing a suspected instrument problem, or simply to check functionality.

Appendix A: Specifications

This appendix contains the NORTEC 600 instrument specifications.

A.1 General and Environmental Specifications

Table 6 on page 339 provides the general and environmental specifications.

Table 6 General and environmental specifications

Category	Parameter	Value
Housing	Overall dimensions (width × height × depth)	236 mm × 167 mm × 70 mm (9.3 in. × 6.57 in. × 2.76 in.)
	Weight	1.7 kg (3.75 lb), including lithium-ion battery
	Other	Factory-installed hand strap and back instruction label

Table 6 General and environmental specifications (continued)

Category	Parameter	Value
Environmental conditions	Operating temperature	-10 °C to 50 °C (14 °F to 122 °F)
	Storage temperature	0 °C to 50 °C (32 °F to 122 °F) [with batteries] -20 °C to 70 °C (-4 °F to 158 °F) [without batteries]
	IP rating	Designed to meet requirements of IP66
	Drop tested	Method 516.6 Procedure IV, 26 drops, package for shipment
	Shock tested	MIL-STD-810F, Method 516.5 Procedure I, 6 cycles each axis, 15G, 11 ms half sine shock testing
	Vibration tested	MIL-STD-810F, Method 514.5, Procedure I, Annex C, Figure 6, general exposure: 1 hour each axis vibration test
	Protective bag operation	Knobless mode is used to calibrate signals when unit is placed in protective bag.
Batteries	Battery model and type	600-BAT-L-2 (Li-ion) [U8760058] Single lithium-ion rechargeable battery or AA-size alkaline batteries (in 8-cell holder)
	Battery quantity	1
	Battery storage temperature	0 °C to 50 °C (32 °F to 122 °F) at 80 % relative humidity
	Battery charge time	4.3 hours when charging inside the instrument or when using an optional external battery charger
	Battery life	Over 10 hours for standard operation and 6 hours to 8 hours when operating rotating scanners
	Battery size	Height: 22.3 mm (0.9 in.) Length: 214.6 mm (8.5 in.) Width: 58.9 mm (2.4 in.)

Table 6 General and environmental specifications (continued)

Category	Parameter	Value
External DC supply	DC-IN voltage	24 VDC (60 W)
	DC connector	Circular, 2.5 mm pin diameter, center-positive
	DC supply, external (suggested charger/adapter model)	EP-MCA-X (X indicates the power cord model; see Table 12 on page 349)
Display	Display size (W × H, diagonal)	117.4 mm × 88.7 mm, 146.3 mm (4.62 in. × 3.49 in., 5.76 in.)
	Display resolution	640 × 480 pixels
	Number of colors	256 colors
	Display type	Full VGA, color transfective LCD (liquid crystal display)
	Display viewing angles	Horizontal: -80° to 80° Vertical: -80° to 80°
	Screen modes	Normal or Full screen
	Grid and display tools	Choice of 5 grids (OFF , 10 × 10 , FINE , COARSE , and WEB) and user-selected crosshairs on single and dual impedance plane views only
	Display modes (all possible)	Available display modes depend on instrument model and selected operating mode. Available displays are: Single impedance plane (IMP) Sweep display (SWEEP) Combined impedance and sweep display (SWP+IMP) Dual impedance plane (DUAL IMP) All-in-one display (ALL-IN-1) featuring up to three configurable traces Waterfall display for rotating scanner (WATERFALL)
Input and Outputs	USB	One USB 2.0 peripheral port
	Video output	One standard VGA analog output port
	Input/Output	One 15-pin I/O port (male) with 6 analog outputs, 4 alarm outputs (which can become inputs), and 2 encoder signals (future expansion)

Table 6 General and environmental specifications (continued)

Category	Parameter	Value
Eddy current specifications	Probe types	Absolute and differential, in either bridge or reflection configuration. The instrument is fully compatible with NORTEC PowerLink probes, as well as other main probe and accessory suppliers.
	Probe connectors	16-pin LEMO and BNC
	Balancing	Internal automatic balancing for BNC connector (absolute probes)
	Number of probe inputs	1
	Frequency range	10 Hz to 12 MHz
	Gain	0 dB to 100 dB in 0.1 dB or 1 dB increments
	Rotation	0° to 359.9° in 0.1° or 1° increments
	Sweep	Variable from 0.005 s to 10 s per division (total of 13.3 divisions with FINE grid)
	Low Pass filter	10 Hz to 2000 Hz and wide band
	High Pass filter	Off or 2 Hz to 1000 Hz, user-selectable in constant Figure 6 or Figure 8 filter type
	Continuous null (very low frequency high-pass filter)	0.2 Hz, 0.5 Hz, and 1.0 Hz
	Probe drive	LOW, MEDIUM and HIGH (2 volts, 5 volts, and 8 volts)
	Automatic Lift-Off	Yes
	Variable persistence	0.1 s to 10 s
	Variable display erase	0.1 s to 60 s
Display modes	Single Impedance, Sweep (strip chart), and Split Screen.	

Table 6 General and environmental specifications (continued)

Category	Parameter	Value
Conductivity (NORTEC 600C, NORTEC 600S and NORTEC 600D)	Frequency	60 kHz or 480 kHz
	Digital conductivity specification	Digital conductivity display from 0.9 % to 110 % IACS or 0.5 MS/m to 64 MS/m. Accuracy within ± 0.5 % IACS from 0.9 % to 62 % IACS and within ± 1.0 % of values over 62 %. Meets or exceeds BAC 5651 specifications. Accuracies depend on probe frequency, range of calibration, and coating thickness.
	Non-conductive coating thickness	Nominal accuracy of nonconductive coating thickness of ± 0.025 mm (± 0.001 in.) from 0 mm to 0.254 mm (0.00 in. to 0.010 in.) range, and ± 0.50 mm over 10 mm to 0.5 mm (0.01 in. to 0.020 in.) range. Accuracies depend on conductivity range, probe frequency, and range of calibration.
	Interface	Easy to follow conductivity Wizard with adjustment of reference points and coating thickness (shims).
Scanners (NORTEC 600S and NORTEC 600D)	Scanner compatibility	Operates Evident scanners (Mini-Mite, SpitFire, RA-2000, and PS-5) and other major suppliers' scanners.
	Scanner speed range	40 rpm to 3000 rpm
	Display modes	Single Impedance, Sweep (strip chart), Split Screen, and Waterfall.
	Waterfall display	60 sweeps per hole
Dual Frequency (NORTEC 600D)	Frequency adjustment (dual frequency mode)	Fully independent frequencies, operating in simultaneous injection
	Number of channels	3 (frequency 1, frequency 2, and mix [NORTEC 600D only])
	Display modes	New all-in-one display, Dual Impedance, Single Impedance, Sweep (strip chart), and Split Screen (sweep + impedance).
	MIX options	F1 – F2, F1 + F2, and automatic true mixing

Table 6 General and environmental specifications (continued)

Category	Parameter	Value
Alarms	Alarm quantity	3 simultaneous alarms
	Available alarm types	Choice of BOX (rectangle), POLAR (circle), SECTOR (pie), SWEEP (time-based), CONDUCTIVITY , and COATING THICKNESS
Connectivity and memory	PC software	NORTEC PC software, included in base NORTEC 600 kit. NORTEC PC allows viewing of saved files and printing of reports.
	On-board preview	Yes — selectable with knob
	Data storage	500 files featuring on-board preview
	Reference signal	Instant or recalled from memory
Interface	Languages	English, Spanish, French, German, Italian, Japanese, Chinese, Russian, Portuguese, Polish, Dutch, Korean, Czech, Hungarian, Swedish, and Norwegian
	Ambidextrous mode	Switch to ambidextrous mode to place the most commonly-used controls at the right side of the instrument.
	Supervisor mode	Password-protected supervisor mode to lock instrument menus and keys.
	Instrument modes	Single frequency, dual frequency, or conductivity
	Menu structure	Single menu-level interface with All Settings form for easy configuration from a procedure
	Applications	Application selection menu for easy and rapid configuration
	Real-time readings	Choice of up to 2 real-time readings to measure signal characteristics (selection of 5 amplitude measurements and 2 angle measurements)
	Colors	8 schemes to accommodate all lighting conditions and user preferences

A.2 Input/Output Specifications

The specifications for the USB, video output, and input/output signals are provided in Table 6 on page 339.

Table 7 on page 345 describes all the connections available on the 15-pin I/O connector. Table 8 on page 346 describes all the connections available on the VGA OUT 15-pin connector. Connector-pin numbering is shown in Figure A-1 on page 345.

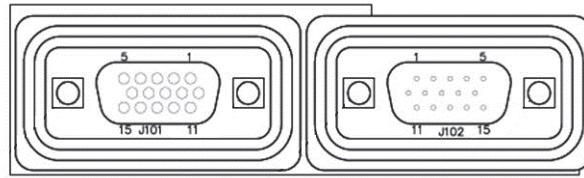

Figure A-1 Pin numbers on connectors

NOTE

The NORTEC 600 instrument incorporates an alarm output (high = 5 V [on] and low = 0 V [off]). The alarm output is not intended to directly operate devices at a current and voltage different from that used by the NORTEC 600's dedicated external alarm. However, the alarm output can be used to control logic-type actuated relays, which in turn can control other electromechanical devices such as magnetic coil relays, indication lights, etc.

Table 7 NORTEC 600 Input/Output 15-pin I/O connector

Pin	Signal	Description
1	AOUT_1	Analog Output 1 (-5 V to +5 V) Meaning: F1 X
2	AOUT_2	Analog Output 2 (-5 V to +5 V) Meaning: F1 Y
3	AOUT_3	Analog Output 3 (-5 V to +5 V) Meaning: F2 X
4	AOUT_4	Analog Output 4 (-5 V to +5 V) Meaning: F2 Y
5	AOUT_5	Analog Output 5 (-5 V to +5 V) Meaning: Mix X

Table 7 NORTEC 600 Input/Output 15-pin I/O connector (continued)

Pin	Signal	Description
6	AOUT_6	Analog Output 6 (-5 V to +5 V) Meaning: Mix Y
7	GND	Ground
8	VDD	+5 V voltage
9	ENCD_INT	Encoder Interrupt (future expansion)
10	ENCD_DIR	Encoder Direction (future expansion)
11	GND	Ground
12	HW_IO_1	Alarm Output 1 (TTL)
13	HW_IO_2	Alarm Output 2 (TTL)
14	HW_IO_3	Alarm Output 3 (TTL)
15	Unused	Unused (for future expansion)

Table 8 NORTEC 600 VGA 15-pin port output^a

Pin	Signal	Description
1	VGA_RED	VGA red output
2	VGA_GREEN	VGA green output
3	VGA_BLUE	VGA blue output
4	NC	Not connected
5	GND	Ground
6	GND	Ground
7	GND	Ground
8	GND	Ground
9	NC	Not connected
10	GND	Ground
11	NC	Not connected
12	NC	Not connected
13	LCD_HSYNC	Horizontal sync.
14	LCD_VSYNC	Vertical sync.
15	NC	Not connected

a. Standard VGA output configuration

Appendix B: Accessories, Replacement Parts, and Upgrades

Table 9 on page 347 through Table 16 on page 350 contain part numbers for NORTEC 600 accessories, replacement parts and upgrades.

Table 9 Standard accessories and replacement parts

Description	Part number
600 Series instrument transport case	600-TC [U8780294]
Charger/adapter (DC supply) with configured power cord	EP-MCA-X (for cable variable X and item number see Table 12 on page 349)
NORTEC PC software and N600 full manuals CD (all languages)	N600-CD [U8030151]
ISO-15548 certificate of calibration	7922035 [U8030145]
600 Series rechargeable Li-ion battery (73 Wh)	600-BAT-L-2 [U8760058]
8-cell battery holder (tray) with connector plug	600-BAT-AA [U8780295]
USB communication cable	EPLTC-C-USB-A-6 [U8840031]
2 GB microSD memory card	MICROSD-ADP-2GB [U8779307]
Probe cable, 1.83 m (6 ft) length, PowerLink bridge/reflection cable (CL/SC/6) Note: Although in some countries this item may be included, for most countries it is optional and must be purchased separately. Please contact your Evident representative for more details.	9122083 [U8800073]
Hand strap (factory installed on left side of NORTEC 600)	38DLP-HS [U8779371]

Table 10 Optional accessories and support items

Description	Part number
Chest harness (4-point connection)	EP4/CH [U8140055]
600 Series instrument stand assembly	600-STAND [U8780296]
N600 external alarm booster adapter	N600-EXTALM [U8780332]
600 Series VGA output cable, 1.52 m (5 ft) length	600-C-VGA-5 [U8780298]
Communication cable HD15, female, single ended, 1.83 m (6 ft) length	DSUB-HD15-6 [U8780333]
Probe cable, 1.83 m (6 ft) length, PowerLink bridge/reflection cable (CL/SC/6) Note: Although in some countries this item may be included, for most countries it is optional and must be purchased separately. Please contact your Evident representative for more details.	9122083 [U8800073]
600 Series products display protectors (pack of 10)	600-DP [U8780297]
600 Series soft instrument and accessory case (knob version)	600-SC-K [U8780334]
External battery charger with configured power cord	EPXT-EC-X (for cable variable X and item number see Table 12 on page 349)
Shoulder strap	3319871 [U8906253]

Table 11 NORTEC 600 instrument upgrades

Description	Part number
NORTEC 600 Extended Warranty (one additional year) including calibration	W2-NORTEC600 [U8832002]
N600 to N600C upgrade, including one probe and standard	N600-UPG-C [U8832003]
N600 to N600C upgrade, software only	N600-UPG-C-SW [U8832047]
N600 to N600S upgrade	N600-UPG-S [U8832004]
N600 to N600D upgrade	N600-UPG-D [U8832005]
N600C to N600S upgrade	N600-UPG-C-S [U8832006]
N600C to N600D upgrade	N600-UPG-C-D [U8832007]
N600S to N600D upgrade	N600-UPG-S-D [U8832008]

Table 12 Power cords for charger EP-MCA-X and EPXT-EC-X

Description for charger-cord variable (X)	Item number
A = Australia	U8840005
B = Brazil	U8769007
C = China	U8769008
D = Denmark	U8840011
E = Europe	U8840003
I = Italy	U8840009
J = Japan Power Cord and PSE Insertion Sheet	U8908649
K = U.K.	U8840007
P = India, Pakistan, S. Africa, and Hong-Kong	U8840013
S = South Korea	U8769009
U = U.S.A and Canada	U8840015

Table 13 Conductivity accessories (for N600C model only)

Description	Part number
60 kHz conductivity probe, 19 mm (0.750 in.) diameter	9222340 [U8690027]
Traceable conductivity standards with certificates. Set of two standards: 29 % to 59 %	9522111 [U8880084]
0.1 mm (0.004 in.) thick nonconductive shim	320806 [U8840160]
Conductivity probe, shim and standard kit	N600-UPG-C-HW [U8250224]

Table 14 adapter cables for scanners from other manufacturers

Description	Part number
adapter cable for GE minidrive rotating scanner into NORTEC 600	9122360 [U8800878]
adapter cable for Rohmann MR3 rotating scanner into NORTEC 600	9122234 [U8800090]

Table 15 Getting Started Guide – all languages

Description	Part number
N600 Getting Started - Chinese	DMTA-10039-01ZH [U8778671]
N600 Getting Started - English	DMTA-10039-01EN [U8030146]
N600 Getting Started - French	DMTA-10039-01FR [U8778673]
N600 Getting Started - German	DMTA-10039-01DE [U8778672]
N600 Getting Started - Italian	DMTA-10039-01IT [U8778674]
N600 Getting Started - Portuguese	DMTA-10039-01PT [U8778678]
N600 Getting Started - Japanese	DMTA-10039-01JA [U8778675]
N600 Getting Started - Russian	DMTA-10039-01RU [U8778676]
N600 Getting Started - Spanish	DMTA-10039-01ES [U8778677]

Table 16 Heat exchanger tubing accessories – for N600D model only

Part number	Description
CBAS-10818-0001 [Q7670051]	Compatible with N600D only. Differential and absolute eddy current tube probe adapter, with PowerLink. 4-pin Amphenol to 16-pin LEMO. 30 cm (1 ft) length. Compatible with Evident TEA/TEB, TEC/TED, TEE/TEF, TEG, TEK/TEL, and TEO series MS5800 eddy current bobbin probes, and most bobbin probes from other manufacturers.
CBAS-10819-0001 [Q7670052])	Compatible with N600D only. Differential only near-field tube probe adapter, with PowerLink. 19-pin BENDIX to 16-pin LEMO. 30 cm (1 ft) length. Compatible with TRD series MS5800 near-field tube probes.
CBAS-10820-0001 [Q7670053])	Compatible with N600D only. Absolute only near-field tube probe adapter, with PowerLink. 19 pins BENDIX to 16-pin LEMO. 30 cm (1 ft) length. Compatible with TRD series MS5800 near-field tube probes.
CBAS-10821-0001 [Q7670054]	Compatible with N600D only. Differential and absolute remote-field tube probe adapter, with PowerLink and active circuitry. 19-pin BENDIX to 16-pin LEMO. 30 cm (1 ft) length. Compatible with TRS and TRX series MS5800 remote-field probes.
9122404 [Q7670008]	N600 foot switch replacement armored cable. Triax Fischer/LEMO to Triax Fischer/LEMO connectors, 4.5 m (15 ft) length.
9522336 [Q2500083]	N600 foot switch adapter, 16-pin LEMO. Gives the ability to NULL and ERASE the N600 instrument via the optional NULL/ERASE foot switch P/N 9522333 (Q7670007) and the optional armored cable P/N 9122404 (Q7670008).

Table 16 Heat exchanger tubing accessories — for N600D model only (continued)

Part number	Description
9522333 [Q7670007]	N600 foot switch with NULL and ERASE controls.
CASE-10086 [Q7640004]	Rugged transport case for N600 heat exchanger tubing inspection kit (HX-ADPT-KIT).
HX-ADPT-KIT [Q7670041]	<p>NORTEC 600 heat exchanger tubing inspection adapter kit for eddy current (ECT), near field (NFT) and remote field (RFT). Compatible with NORTEC 600D (dual frequency) only.</p> <p>This kit includes the following items:</p> <ul style="list-style-type: none"> • One CBAS-10818-0001 differential and absolute eddy current tube probe adapter, with PowerLink. 4-pin Amphenol to 16-pin LEMO. 30 cm (1 ft) length. Compatible with Evident TEA/TEB, TEC/TED, TEE/TEF, TEG, TEK/TEL, and TEO series MS5800 eddy current bobbin probes and most bobbin probes from other manufacturers. • One CBAS-10819-0001 differential only near-field tube probe adapter, with PowerLink. 19-pin BENDIX to 16-pin LEMO. 30 cm (1 ft) length. Compatible with TRD series MS5800 near-field tube probes. • One CBAS-10820-0001 absolute only near-field tube probe adapter, with PowerLink. 19-pin BENDIX to 16-pin LEMO. 30 cm (1 ft) length. Compatible with TRD series MS5800 near-field tube probes. • One CBAS-10821-0001 differential and absolute remote-field tube probe adapter, with PowerLink and active circuitry. 19-pin BENDIX to 16-pin LEMO. 30 cm (1 ft) length. Compatible with TRS and TRX series MS5800 remote-field probes. • One 9122404 foot switch armored cable. Triax Fischer/LEMO to Triax Fischer/LEMO connectors, 4.5 m (15 ft) length. • One 9522336 foot switch adapter, 16-pin LEMO • One 9522333 foot switch with NULL and ERASE controls • One CASE-10086 rugged transport case • One info card (list of items in kit) • One spare compartment for NORTEC 600 instrument. IMPORTANT: The NORTEC 600 instrument is NOT included in this kit and must be ordered separately.

List of Figures

Figure i-1	The NORTEC 600 instrument	25
Figure 1-1	Transport case contents	29
Figure 1-2	The NORTEC 600 connections	30
Figure 1-3	The top end connectors	30
Figure 1-4	The connectors behind the input/output (I/O) door	31
Figure 1-5	The VGA OUT and I/O connectors	32
Figure 1-6	Location of the NORTEC 600 power button and indicator light	33
Figure 1-7	The charger/adaptor indicator light on the front panel	33
Figure 1-8	Connecting the charger/adaptor	34
Figure 1-9	Connecting the DC power cable	35
Figure 1-10	The battery compartment	36
Figure 1-11	Removing the lithium-ion battery	38
Figure 1-12	The alkaline battery holder	39
Figure 1-13	Installing the microSD card	40
Figure 1-14	Overview of the NORTEC 600 hardware – Front view	41
Figure 1-15	Overview of the NORTEC 600 hardware – Back view	42
Figure 1-16	The NORTEC 600 front panel with SmartKnob and keypad.....	43
Figure 1-17	The NORTEC 600 English keypad	44
Figure 1-18	The NORTEC 600 Chinese keypad	44
Figure 1-19	The NORTEC 600 Japanese keypad	45
Figure 1-20	The NORTEC 600 international keypad	45
Figure 1-21	Location of the PROBE (LEMO) and BNC connectors	48
Figure 1-22	The VGA OUT and I/O connectors	49
Figure 1-23	The microSD slot and USB port	50
Figure 1-24	Instrument stand	51
Figure 2-1	The instrument label showing keypad functions	55
Figure 2-2	Application choices on the quick-setup menu	56
Figure 2-3	The PowerLink recognition screen	57
Figure 2-4	The main inspection screen	58
Figure 2-5	The NORTEC 600 front panel and main inspection screen	59

Figure 2-6	The ALL SETTINGS menu	61
Figure 2-7	Example of VPP and DEG PP	63
Figure 2-8	Example of HPP	63
Figure 2-9	Example of VPP	64
Figure 2-10	Example of HMAX	64
Figure 2-11	Example of VMAX	65
Figure 3-1	The SYSTEM SETUP screen	69
Figure 4-1	The PowerLink recognition screen	75
Figure 4-2	The NORTEC 600 instrument controls.....	76
Figure 4-3	Probe liftoff—initially not horizontal	79
Figure 4-4	The LIFT PROBE message after holding the A-LIFT NULL key	79
Figure 4-5	Probe liftoff after nulling	80
Figure 4-6	Freezing the current image on the instrument screen	81
Figure 4-7	The UP and DOWN function in knobless entry	84
Figure 4-8	The SYSTEM SETUP screen	86
Figure 4-9	The controls displayed on the right side of the instrument	86
Figure 4-10	The settings display (<i>left</i>) and maximized display (<i>right</i>)	87
Figure 4-11	Using the FULL NEXT key to navigate a menu	87
Figure 4-12	The EDDY CURRENT SLIDE RULE menu	93
Figure 4-13	The SHOW READINGS function	99
Figure 4-14	The HIDE READINGS function	99
Figure 4-15	The STORE function	101
Figure 4-16	The FILE MANAGER menu’s memory text editor and special buttons .	103
Figure 4-17	The application selection menu	106
Figure 4-18	The ALL SETTINGS menu (first of two screens)	107
Figure 4-19	The FREQ 1 menu	108
Figure 4-20	The FREQ 2 menu	109
Figure 4-21	The PASSWORD menu	110
Figure 4-22	The SYSTEM SETUP screen	111
Figure 4-23	The ABOUT menu	112
Figure 4-24	The REGULATORY SCREEN	113
Figure 4-25	The RESET menu	115
Figure 5-1	Materials—surface-breaking cracks	126
Figure 5-2	The Surface Cracks application	127
Figure 5-3	The automatic lift-off function	129
Figure 5-4	The lift-off signal as close as possible to horizontal	129
Figure 5-5	Adjusting the horizontal gain	130
Figure 5-6	Adjusting the vertical gain	130
Figure 5-7	The final calibration check	131
Figure 5-8	The full-screen mode for fine-tuning the settings	132
Figure 5-9	The list of all parameters	132
Figure 5-10	Materials—fastener holes with rotating scanner	133

Figure 5-11	The Bolt Hole application	134
Figure 5-12	The bolt-hole signal	135
Figure 5-13	Adjusting the lift-off noise (first alternative)	135
Figure 5-14	Adjusting the lift-off noise (second alternative)	136
Figure 5-15	Adjusting the gain	137
Figure 5-16	Adjusting the vertical gain	137
Figure 5-17	The full-screen mode for fine-tuning the settings	138
Figure 5-18	The list of all parameters for aluminum	139
Figure 5-19	An example display for a steel hole	140
Figure 5-20	The list of all parameters in ferromagnetic material	140
Figure 5-21	Comparing the Figure 6 (<i>left</i>) and Figure 8 filter signals	141
Figure 5-22	Materials—sub-surface cracks at very low frequency	142
Figure 5-23	The Sub-Surface application	143
Figure 5-24	The signal on the cracked fastener	144
Figure 5-25	The lower lift-off signal as close as possible to horizontal	144
Figure 5-26	Adjusting the vertical gain	145
Figure 5-27	The signal in full-screen mode	145
Figure 5-28	The list of all parameters	146
Figure 5-29	Calibration with frequency too low (<i>left</i>) or too high (<i>right</i>)	147
Figure 5-30	Materials—welds on ferromagnetic material	147
Figure 5-31	The Weld and Wheel application	148
Figure 5-32	The longest face of the probe tip	149
Figure 5-33	The signal on the notch	149
Figure 5-34	The notch signal oriented vertically	150
Figure 5-35	Adjusting the vertical gain	150
Figure 5-36	The signal after scanning the entire standard	151
Figure 5-37	The default display of maximum signal amplitude and signal angle	152
Figure 5-38	The scanning motions	153
Figure 5-39	The list of all parameters	154
Figure 5-40	Materials—paint thickness on ferromagnetic material	155
Figure 5-41	The Surface Cracks application	156
Figure 5-42	Decreasing the GAIN to adjust the signal	157
Figure 5-43	Adjusting V POS to create a vertical mark	157
Figure 5-44	The vertical lines for different thicknesses	158
Figure 5-45	Using the vertical reference marks for thickness evaluation	159
Figure 5-46	The list of all parameters	159
Figure 5-47	Materials—conductivity and non-conductive coating thickness	160
Figure 5-48	Accessing the Conductivity function	161
Figure 5-49	The displayed instruction (1) after PowerLink acceptance	161
Figure 5-50	The displayed instruction (3)	162
Figure 5-51	The displayed instruction (4)	163
Figure 5-52	The confirmation of a completed calibration	163

Figure 5-53	Materials—aircraft wheels	166
Figure 5-54	The Surface Cracks application	167
Figure 5-55	The signals extending across the screen	168
Figure 5-56	Scanning the center notch	168
Figure 5-57	Setting the signal as close as possible to horizontal	169
Figure 5-58	The signals extending vertically across the screen	169
Figure 5-59	The results after scanning the standard	170
Figure 5-60	The Alarm parameters	171
Figure 5-61	The signal after fine tuning	172
Figure 5-62	The list of all parameters	172
Figure 5-63	The Indexing Scanner application	173
Figure 5-64	The Figure 6 filter	174
Figure 5-65	Adjusting the signal angle	175
Figure 5-66	Adjusting the gain	175
Figure 5-67	Adjusting the vertical gain	176
Figure 5-68	Adjusting the sync angle	176
Figure 5-69	Using the waterfall cursor	178
Figure 5-70	The scan result	178
Figure 5-71	The list of all parameters	179
Figure 5-72	Materials—special and educational applications	180
Figure 5-73	The Surface Cracks application	181
Figure 5-74	The section of the standard used for impedance plane theory	182
Figure 5-75	Adjusting the signal angle to 90°	182
Figure 5-76	Adjusting the gain	183
Figure 5-77	Displaying the effect of conductivity and magnetic permeability	183
Figure 5-78	The Surface Cracks application	184
Figure 5-79	The section of the standard used for conductivity evaluation	185
Figure 5-80	The signals from different conductivity samples	185
Figure 5-81	Adjusting the lower signal to horizontal	186
Figure 5-82	Adjusting the vertical gain	186
Figure 5-83	Using the vertical position of the signal to accept or reject the sample ...	187
Figure 5-84	The Surface Cracks application	188
Figure 5-85	The back of the standard	188
Figure 5-86	Adjusting the lift-off angle to 90°	189
Figure 5-87	Adjusting the gain	189
Figure 5-88	Using H POS to create a horizontal mark	190
Figure 5-89	Creating more horizontal marks	190
Figure 5-90	Using the vertical signal deflection to evaluate unknown thicknesses ...	191
Figure 5-91	The Surface Cracks application	192
Figure 5-92	The section of the standard used for metal thickness	192
Figure 5-93	The scan of the tapered area	193
Figure 5-94	Adjusting the lift-off angle to horizontal	194

Figure 5-95	Adjusting the gain	194
Figure 5-96	The scan of the tapered part	195
Figure 5-97	Materials—dual frequency for corrosion	196
Figure 5-98	The Dual Frequency Sub-Surface application	197
Figure 5-99	The list of dual frequency parameters	198
Figure 5-100	Position 1 of the standard	199
Figure 5-101	Adjusting the angle of the frequency 1 lift-off signal	199
Figure 5-102	Adjusting the angle of the frequency 2 lift-off signal	200
Figure 5-103	Position 2 on the standard	200
Figure 5-104	The frozen signals	201
Figure 5-105	Adjusting the gain for frequency 1	201
Figure 5-106	Adjusting the gain for frequency 2	202
Figure 5-107	Adjusting the H GAIN for frequency 1	203
Figure 5-108	Adjusting the H GAIN 2 value	203
Figure 5-109	Adjusting the H GAIN value	204
Figure 5-110	Adjusting the H MIX GN value	205
Figure 5-111	Adjusting the V MIX GN value	205
Figure 5-112	The corrosion-defect scan result	206
Figure 5-113	The list of all parameters	207
Figure 5-114	Materials—dual frequency for sub-surface cracks	208
Figure 5-115	The Dual Frequency Sub-Surface application	209
Figure 5-116	The list of dual frequency parameters	210
Figure 5-117	Position 1 on the standard	211
Figure 5-118	Adjusting the ANGLE value	211
Figure 5-119	Adjusting the ANGLE 2 value	212
Figure 5-120	Adjusting the amplitude of the frequency 1 signal	212
Figure 5-121	Adjusting the amplitude of the frequency 2 signal	213
Figure 5-122	The fastener scan result	214
Figure 5-123	Adjusting the horizontal amplitude of the frequency 1 signal	214
Figure 5-124	Adjusting the vertical amplitude of the frequency 1 signal	215
Figure 5-125	Adjusting the horizontal amplitude of the frequency 2 signal	215
Figure 5-126	Adjusting the vertical amplitude of the frequency 2 signal	216
Figure 5-127	Position 3 on the standard	217
Figure 5-128	Adjusting the V GAIN 2 value	217
Figure 5-129	Adjusting the V GAIN value	218
Figure 5-130	Checking the Mix signal	218
Figure 5-131	Adjusting the ANGLE value	219
Figure 5-132	Adjusting the H GAIN 2 value	219
Figure 5-133	The scan results for both fastener rows	220
Figure 5-134	The list of all parameters	221
Figure 5-135	Materials—dual frequency for heat exchanger tubing	222
Figure 5-136	The Heat Exchanger Tubing application	223

Figure 5-137	The scan of the thru-wall hole	224
Figure 5-138	Adjusting the frequency 1 signal phase	225
Figure 5-139	Adjusting the frequency 1 gain	225
Figure 5-140	Adjusting the frequency 2 angle	226
Figure 5-141	The scan of the support ring	226
Figure 5-142	Adjusting the angle of the frequency 2 signal on the support ring	227
Figure 5-143	Adjusting the gain of the frequency 2 signal on the support ring	227
Figure 5-144	The support ring scan with AUTO MIX	228
Figure 5-145	The support ring's signal successfully subtracted	229
Figure 5-146	The scan of the thru-wall hole	229
Figure 5-147	Fine-tuning the MIX angle	230
Figure 5-148	The scan of the flat-bottom holes	230
Figure 5-149	The list of all parameters	231
Figure 5-150	The strip chart display	232
Figure 5-151	The web grid display	233
Figure 5-152	The display with adjusted null point and coarse grid	234
Figure 5-153	An example of marking the probe positions	236
Figure 5-154	ECT principles	237
Figure 5-155	An example of an ECT differential signal response	238
Figure 5-156	An air conditioner probe	238
Figure 5-157	Signals from an A/C probe's pancake surface coils only	239
Figure 5-158	The ECT Pitting, Wear, and Cracks application	240
Figure 5-159	Example of lower signal lobe when pulling the probe over a flaw	241
Figure 5-160	The scan signal of the thru-wall hole	241
Figure 5-161	Adjusting the signal	242
Figure 5-162	Adjusting the frequency 1 gain	242
Figure 5-163	An example of a nonsaturated support ring signal	243
Figure 5-164	An example of a saturated support ring signal	244
Figure 5-165	The tube scan between the support ring and the thru-wall hole	244
Figure 5-166	The verified signals: thru-wall hole (<i>left</i>) and support ring (<i>right</i>)	245
Figure 5-167	The frequency 2 scan signal of the support ring	246
Figure 5-168	The frequency 2 scan signal of the 1.3 mm (0.052 in.) thru-wall hole	246
Figure 5-169	The frequency 2 scan signal of the 1.3 mm (0.052 in.) thru-wall hole with adjusted angle	247
Figure 5-170	The support ring signal after AUTO MIX	248
Figure 5-171	The thru-wall hole signal after AUTO MIX	249
Figure 5-172	The thru-wall hole signal after AUTO MIX angle adjustment	249
Figure 5-173	The thru-wall hole signal after AUTO MIX gain adjustment	250
Figure 5-174	The tube scan result	251
Figure 5-175	Moving the support ring	252
Figure 5-176	The null position after moving the support ring	252
Figure 5-177	The tube scan result after moving the support ring (MIX)	253

Figure 5-178	The scan result with the support ring over the flaw in FREQ 1	253
Figure 5-179	Tube scan display with reference image (gray) and live signal (orange)	255
Figure 5-180	The FRQ2 DSP menu	256
Figure 5-181	The tube scan with the ALL-IN-1 display	256
Figure 5-182	An example of an ECT absolute signal response	257
Figure 5-183	The ECT Erosion and Corrosion application	258
Figure 5-184	The scan of the two grooves	259
Figure 5-185	Adjusting the signal phase	259
Figure 5-186	Adjusting the gain	260
Figure 5-187	The 10 % ID and 20 % OD flaws set as a reference image	261
Figure 5-188	The tube scan result	261
Figure 5-189	An RFT probe	263
Figure 5-190	An example of an RFT differential signal response	263
Figure 5-191	A dual exciter probe	264
Figure 5-192	Equal response on both sides of a support with a dual exciter probe	264
Figure 5-193	The RFT Pitting and Wear application	265
Figure 5-194	The scan of the thru-wall hole	266
Figure 5-195	Adjusting the signal phase	267
Figure 5-196	Adjusting the gain	267
Figure 5-197	A slow scan rate (optimal signal, <i>left</i>) and a fast scan rate (loss of signal, <i>right</i>)	268
Figure 5-198	The support ring's signal clipped (<i>left</i>) and with adjusted gain (<i>right</i>)	269
Figure 5-199	The scan of the entire length of the tube	270
Figure 5-200	Angle adjustment in FREQ 2	270
Figure 5-201	GAIN adjustment in FREQ 2	271
Figure 5-202	Verification signal in FREQ 2	271
Figure 5-203	The MIX menu	272
Figure 5-204	The scan of entire tube length after AUTO MIX	273
Figure 5-205	The signal after AUTO MIX (<i>left</i>); with angle/gain adjustment (<i>right</i>)	274
Figure 5-206	A scan with 10 Hz LO PASS filter (<i>left</i>); with scan rate too fast (<i>right</i>)	275
Figure 5-207	ALL-IN-1 display of cluster of 4 corrosion pits under support ring	276
Figure 5-208	ALL-IN-1 display with support ring within 3.2 mm (0.125 in.) of 75 % corrosion pit	277
Figure 5-209	An example of an RFT absolute signal response	277
Figure 5-210	A single exciter probe	278
Figure 5-211	A large defect detected on both sides of a support using the absolute (ABS) channel	278
Figure 5-212	The RFT Erosion and Corrosion application	279
Figure 5-213	The scan of the two grooves	280
Figure 5-214	Adjusting the signal phase	280
Figure 5-215	Adjusting the gain and angle	281
Figure 5-216	The 40 % OD and 60 % OD flaws set as a reference image	282

Figure 5-217	The scan of the entire length of the tube	282
Figure 5-218	Renaming the file	283
Figure 5-219	The overlay (background voltage plane for absolute RFT signal analysis) and the scan of the tube	284
Figure 5-220	The readings for 40 % OD loss (left) and 60 % OD loss (right)	285
Figure 5-221	A finned air-cooler tube (fin-fan)	285
Figure 5-222	The NFT inspection technology	286
Figure 5-223	The differential exciter-pickup configuration	286
Figure 5-224	Example NFT signal responses (differential configuration)	287
Figure 5-225	The NFT Pitting application	288
Figure 5-226	Example of lower signal lobe when pulling the probe over a flaw	289
Figure 5-227	The scan signal of the thru-wall hole	289
Figure 5-228	Adjusting the signal phase	290
Figure 5-229	Adjusting the gain	290
Figure 5-230	The SWP + IMP display	291
Figure 5-231	The SWP + IMP display after inspecting the entire tube	292
Figure 5-232	An NFT probe with an absolute exciter-pickup configuration	292
Figure 5-233	Example signal response (NFT absolute configuration)	293
Figure 5-234	The NFT Erosion and Corrosion application	294
Figure 5-235	The scan signal of the 60 % wall-loss groove	295
Figure 5-236	Adjusting the signal phase	295
Figure 5-237	Adjusting the gain	296
Figure 5-238	The 40 % wall-loss groove (<i>left</i>) and 60 % wall-loss groove (<i>right</i>)	297
Figure 5-239	The SWP + IMP display after inspecting the entire tube	298
Figure 5-240	Alarm DEFINE menu	299
Figure 5-241	Alarm polarity	300
Figure 5-242	Alarm menu	301
Figure 5-243	Alarm polarity	302
Figure 6-1	The Import File Wizard dialog box	304
Figure 6-2	The Import File Wizard folder selection	304
Figure 6-3	The Import File Wizard file selection	305
Figure 6-4	The Import File Wizard transfer process start	305
Figure 6-5	The Import File Wizard transfer process completion	306
Figure 6-6	The NORTEC PC Device menu	307
Figure 6-7	The Capture Screen dialog box	307
Figure 6-8	The ABOUT menu	308
Figure 6-9	The UPGRADE menu	309
Figure 6-10	The message indicating the charger/adaptor is not connected	309
Figure 6-11	The message indicating the charger/adaptor is connected	310
Figure 6-12	The Utilities menu	310
Figure 6-13	The Upgrade Device dialog box	311
Figure 6-14	Files in the left pane of the NORTEC PC window	313

Figure 6-15	The File menu	314
Figure 6-16	Selecting the Remote Command	314
Figure 6-17	The Device menu — Issue Command	315
Figure 6-18	The Issue Command dialog box	315
Figure 6-19	The Remote Command dialog box	324
Figure 6-20	The knob functions in remote control operation	325
Figure 6-21	The File Manager command	325
Figure 6-22	The Manage File dialog box	326
Figure 6-23	The Confirmation dialog box for file deletion	327
Figure 6-24	The Rename dialog box	327
Figure 6-25	Message asking you to confirm the recall	328
Figure 6-26	The Unlock Options command	329
Figure 6-27	The Unlock Options dialog box	329
Figure 6-28	The microSD card location	330
Figure 6-29	The Backup command	331
Figure 6-30	The Backup dialog box (start)	331
Figure 6-31	The Confirmation dialog box to confirm backup start	331
Figure 6-32	The Backup dialog box (complete)	332
Figure 6-33	The Restore command	332
Figure 6-34	The Restore dialog box (start)	333
Figure 6-35	The Confirmation dialog box to confirm the restore start	333
Figure 6-36	The Restore dialog box (complete)	333
Figure A-1	Pin numbers on connectors	345

List of Tables

Table 1	Charger/adaptor and battery indicators	35
Table 2	Keypad functions	46
Table 3	Reset types	115
Table 4	Recommendations for heat exchanger tubing applications	235
Table 5	NORTEC 600 remote commands	316
Table 6	General and environmental specifications	339
Table 7	NORTEC 600 Input/Output 15-pin I/O connector	345
Table 8	NORTEC 600 VGA 15-pin port output	346
Table 9	Standard accessories and replacement parts	347
Table 10	Optional accessories and support items	348
Table 11	NORTEC 600 instrument upgrades	348
Table 12	Power cords for charger EP-MCA-X and EPXT-EC-X	349
Table 13	Conductivity accessories (for N600C model only)	349
Table 14	adapter cables for scanners from other manufacturers	349
Table 15	Getting Started Guide — all languages	350
Table 16	Heat exchanger tubing accessories — for N600D model only	350

