

Industrial



Eddy Current Probe Kits



**EVIDENT**

# Introduction to Eddy Current Probe Kits

Eddy current probe kits are specifically designed to enable maximum application support in one easy-to-carry package. Kits are available in general or application-specific configurations.

## Training Probe Kit

The general-purpose training kit includes a combination of surface, spot, bolt hole, and sliding probes. It also comes with cables for connecting to a NORTEC™ series eddy current flaw detector, as well as reference standards that can be used with the included probes.



Part Number	Item	Description
		Training Kit Part Number: 10-036249- Detachable 00 (Item Number: Q6700040)
1902474	1	Set of 6 conductivity samples
1902477	1	TB-16 hole standard
1902510	1	TB-S1 aluminum crack standard
1916914	1	SPO-4304 thinning sample
1916915	1	SPO-3932 second layer crack standard
0321004	1	Shim Stock Kit (plastic)
SPO-6687	1	6 ft cable, reflection coil, Triax Fischer/LEMO to N600 instrument (16-pin LEMO)
9122244	1	6 ft cable, bridge coil, 16-pin LEMO to Triax Fischer/LEMO, (SPO-6472)
9213011	1	S/300Hz-10kHz/.62 surface probe
9213012	1	S/1kHz-50kHz/.31 surface probe
9213014	1	P/500kHz-1Mhz/A pencil probe
XEPE-00008	1	P/500kHz-2MHz/D pencil probe
XESL-00003	1	SPO-3806 sliding probe, reflection, probe only, Triax Fischer/LEMO
XEMA-00018	1	B/100kHz-500kHz/A.250, manual bolt hole probe
9216171	1	B/500 kHz-2 MHz/D.250, manual bolt hole probe
9213013.01	1	P/100 KHz-500 kHz/A/90.5/6, right-angle pencil probe
1016873.01	1	Shipping/carrying case

## Scanner Probe Kit

Our Scanner Probe Kit can be used with the MiniMite™ Fischer Kit (kit part number: 9744738, scanner part number: 9020266) or Spitfire 2000™ Scanner Kit (kit part number: 9744668, scanner part number: 9020206).

Our SUB (self-adjusting, universal type with a bell backshell) series expanding eddy current probes include a durable injection, molded plastic tip, and stainless-steel bell backshell. The universal backshell enables easier removal from the scanner. The probes are fitted with the universal 4-Pin Fischer connectors. Their design enables the use of the same probe when holes are reamed to a larger diameter. These probes use a reflection differential type coil operating in the 200 kHz to 3 MHz range. This makes them suitable for all metallic structures.



Kit Part Number	SUBK-8-44	SUBK-8-64
Item Number	U8670107	U8600609
Probe Series	SUB	SUB
Connector Type	4-Pin Fischer	4-Pin Fischer
Range of Hole Size mm (in.)	Included Probes	Included Probes
3.2 to 4 (0.125 to 0.156)	SUB-8-10	SUB-8-10
4 to 4.7 (0.156 to 0.187)	SUB-10-12	SUB-10-12
4.7 to 5.5 (0.187 to 0.218)	SUB-12-14	SUB-12-14
5.5 to 6.4 (0.218 to 0.25)	SUB-14-16	SUB-14-16
6.4 to 7.1 (0.25 to 0.281)	SUB-16-18	SUB-16-18
7.1 to 7.9 (0.281 to 0.312)	SUB-18-20	SUB-18-20
7.9 to 9.5 (0.312 to 0.375)	SUB-20-24	SUB-20-24
9.5 to 11 (0.375 to 0.437)	SUB-24-28	SUB-24-28
11 to 12.7 (0.437 to 0.5)	SUB-28-32	SUB-28-32
12.7 to 14.3 (0.5 to 0.562)	SUB-32-36	SUB-32-36
14.3 to 15.9 (0.562 to 0.625)	SUB-36-40	SUB-36-40
15.9 to 17.4 (0.625 to 0.687)	SUB-40-44	SUB-40-44
17.4 to 19 (0.687 to 0.75)	SUB-44-48	SUB-44-48
19 to 20.6 (0.75 to 0.812)	N/A	SUB-48-52
20.6 to 22.23 (0.812 to 0.875)	N/A	SUB-52-56
22.23 to 23.81 (0.875 to 0.937)	N/A	SUB-56-60
23.81 to 25.4 (0.937 to 1)	N/A	SUB-60-64
Shipping/carrying case	✓	✓

## SPO-5965 Expanding Probes

SPO-5965 expanding probes have a long-wearing plastic tip and stainless-steel backshell. The probes are fitted with Fischer connectors. Their design enables the use of the same probe when holes are reamed to a larger diameter. These probes use a reflection differential type coil operating in the 200 kHz to 3 MHz range. This makes them suitable for all metallic structures.

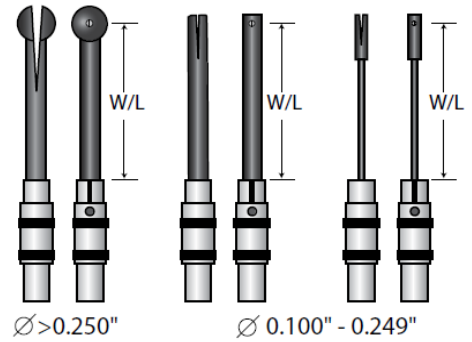

Part Number	9230351	9230721	9231334
Item Number	U8670003	U8670005	U8670013
Probe Series	SPO-5965	SPO-5965	SPO-5965
Connector Type	4-Pin Fischer	4-Pin Fischer	4-Pin Fischer
Range of Hole Size mm (in.)	Included Probes	Included Probes	Included Probes
3.2 to 4 (0.125 to 0.156)	N/A	N/A	9230531
4.0 to 4.7 (0.156 to 0.187)	9230061	9230061	9230061
4.7 to 5.5 (0.187 to 0.218)	9219979	9219979	9219979
5.5 to 6.4 (0.218 to 0.25)	9219980	9219980	N/A
6.4 to 7.1 (0.25 to 0.281)	9219981	9219981	9219981
7.1 to 7.9 (0.281 to 0.312)	9219982	9219982	N/A
7.9 to 9.5 (0.312 to 0.375)	9219983	9219983	9219983
9.5 to 11 (0.375 to 0.437)	9219978	9219978	9219978
11 to 12.7 (0.437 to 0.5)	9219984	9219984	9219984
12.7 to 14.3 (0.5 to 0.562)	9219985	N/A	9219985
14.3 to 15.9 (0.562 to 0.625)	9230156	N/A	9230156
15.9 to 17.4 (0.625 to 0.687)	9230157	N/A	9230157
17.4 to 19 (0.687 to 0.75)	9230158	N/A	9230158
19 to 20.6 (0.75 to 0.812)	N/A	N/A	9230159
22.2 to 23.8 (0.875 to 0.937)	N/A	N/A	9231090
25.4 to 31.7 (1 to 1.25)	N/A	N/A	9231333
Shipping/carrying case	√	√	√

## SPO-3564 Expanding Probes

SPO-3564 expanding probes are used with a MiniMite™ LEMO Kit (kit part number: 9744739, scanner part number: 9020268). These probes have a long-wearing plastic tip, stainless-steel backshell, and are fitted with a 4-pin LEMO connector. Their design enables the use of the same probe when holes are reamed to a larger diameter. These probes use a reflection differential type coil operating in the 200 kHz to 3 MHz range. This makes them suitable for all metallic structures.

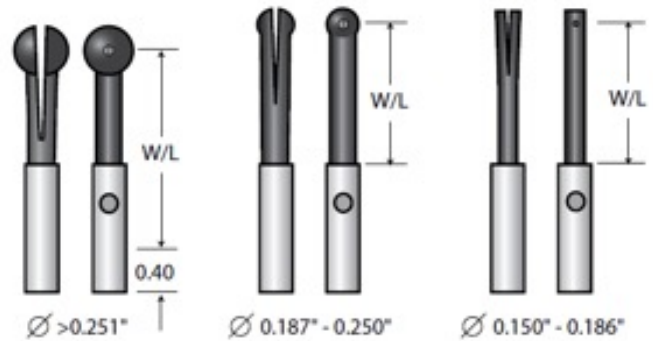

Part Number	Quantity	Description
		<b>SPO-3564 Expandable Scanner Kit</b> <b>Part Number: 9230066 (Item Number: U8670044)</b>
9217153	1	SPO-3564 .187-.218
9217154	1	SPO-3564 .218-.250
9217155	1	SPO-3564 .250-.281
9217156	1	SPO-3564 .281-.312
9217157	1	SPO-3564 .312-.375
9217158	1	SPO-3564 .375-.437
9217159	1	SPO-3564 .437-.500
9217160	1	SPO-3564 .500-.562
9218785	1	SPO-3564 .562-.625
9218786	1	SPO-3564 .625-.687
9218787	1	SPO-3564 .687-.750
9218788	1	SPO-3564 .750-.812
Case	1	Shipping/carrying case

Note: The hole sizes available to order from the SPO-3564 expandable scanner kit (part number: 9216658, item number: U8670041) range from .187-.218 through .500-.562.

## Weld Probe Kits

Weld probes are a cost-effective method to inspect in-service ferrous welds. This inspection method provides a clean, non-hazardous alternative over magnetic particle inspection, as it does not require the removal of coatings such as paint or oxidation. Weld probes offer sensitivity to flaws in varying orientations and may also be suitable for surface inspection on any ferrous material.

Part Number	Item Number	Probe Connector	Description
NEC-8196	U8670016	4-pin LEMO	Probe Kit contains one each of the following in a shipping/carrying case: NEC-2236, WLD-5-63, WLD-8-55, CN16-4L-6, SRSM-51020S-WLD, WLD-SAMPLE
NEC-8196-TF	U8670135	Triax Fischer	Weld Inspection Kit contains one each of the following in a shipping/carrying case: WLD-5-63-TF, WLD-8-55-TF, NEC-2236-2M-TF, SRSM-51020S-WLD, WLD-SAMPLE

## Cables

Part Number	Item Number	Description
CN16-4L-6	U8800276	16-pin LEMO instrument connector to 4-pin LEMO probe connector
9122244	U8800091	16-pin LEMO instrument connector to Triax Fischer/LEMO connector

## Reference Standards

Part Number	Item Number	Description
SRSM-51020S-WLD	U8860571	Weld reference standard, steel, 0.5 mm, 1 mm, and 2 mm deep electrical discharge machined (EDM) notches, paint thickness guides
WLD-SAMPLE	U8860581	Weld sample with four EDM notches, 0.17 mm × 0.5 mm deep with various lengths

Other probe kit options:

- High-Temperature, Low-Wear, and Non-Ferrous Kits are available upon request. For other weld probe options, please review the weld probe brochure.
- Metal Shaft Kits, BondMaster™ Kits, and Wheel Probe Kits are available upon request. Special order and custom-made kits are available upon discussion and validation. Please contact your local sales representative.



# How to Order

For pricing or additional information, contact your local sales representative or reach out to us online at [EvidentScientific.com](https://www.EvidentScientific.com).

- **EVIDENT CORPORATION is ISO14001 certified.**
- **EVIDENT CORPORATION is ISO9001 certified.**

• All company and product names are registered trademarks and/or trademarks of their respective owners.  
• Specifications and appearances are subject to change without any notice or obligation on the part of the manufacturer.  
• NORTEC, BondMaster, MiniMite, and Spitfire 2000 are trademarks of Evident Corporation or its subsidiaries

[EvidentScientific.com](https://www.EvidentScientific.com)

**EVIDENT**

EVIDENT CORPORATION  
Shinjuku Monolith, 2-3-1 Nishi-Shinjuku, Shinjuku-ku, Tokyo 163-0910, Japan

**OLYMPUS**